

(No Model.)

R. L. AMBROSE.
PISTON PACKING RING.

No. 421,646.

Patented Feb. 18, 1890.

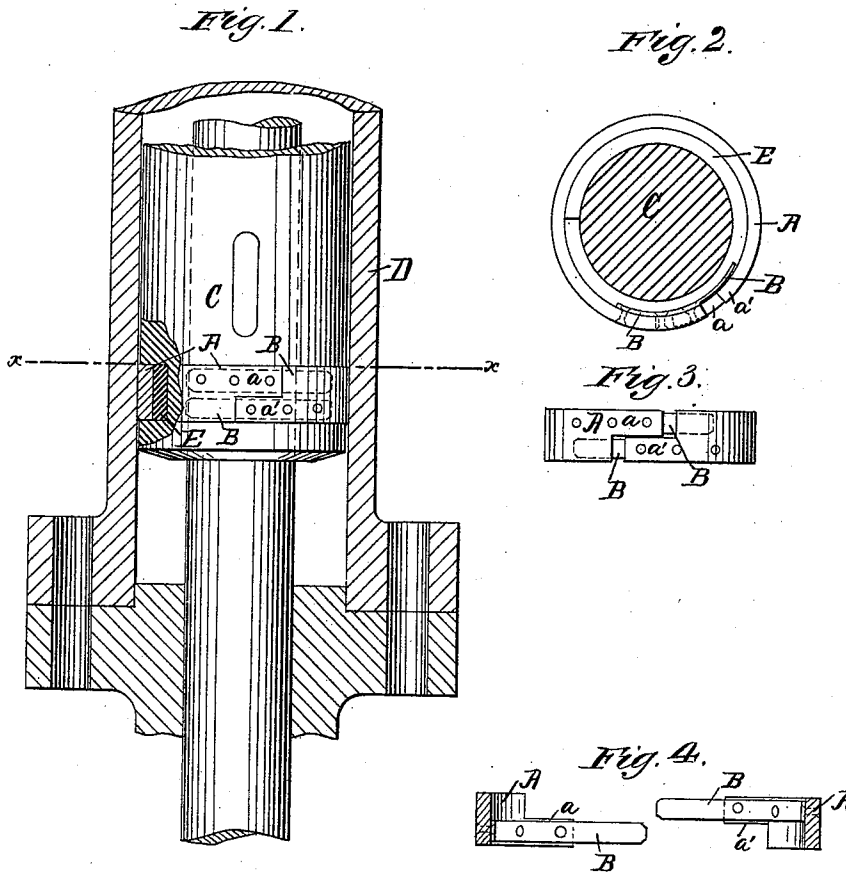

WITNESSES:

A. S. Fitch.
C. W. Benjamin.

INVENTOR

Robert L. Ambrose
BY *A. S. Fitch.*
ATTORNEY

UNITED STATES PATENT OFFICE.

ROBERT LUNNAN AMBROSE, OF BURDEN, ASSIGNOR TO THE RAND DRILL COMPANY, OF NEW YORK, N. Y.

PISTON-PACKING RING.

SPECIFICATION forming part of Letters Patent No. 421,646, dated February 18, 1890.

Application filed June 22, 1887. Renewed July 24, 1889. Serial No. 318,482. (No model.)

To all whom it may concern:

Be it known that I, ROBERT L. AMBROSE, of Burden, county of Columbia, State of New York, and a citizen of the United States, have
5 invented an Improved Piston-Packing Ring, of which the following is a full, clear, and exact description, reference being had to the accompanying drawings, forming part of this specification.

10 My invention relates to a piston-packing ring, and more particularly to one for use in the cylinders of rock-drills; and my invention consists in the combination, with a packing-ring of yielding material having in it an
15 edgewise lap-joint, of the hereinafter-described tongues of stiff material secured fixedly to and projecting one from the under side of each of the ends forming the lap-joint in the ring, and extending from the extremities of said ends across the joint in respectively opposite directions along the inner face
20 of the ring, as and for the purposes hereinafter set forth.

Figure 1 is a longitudinal central sectional
25 view of the lower portion of a cylinder, and showing the piston partly in section with my improved packing-ring in place thereon. Fig. 2 is a cross-section of the parts on the line *x x*, Fig. 1. Fig. 3 is a plan in side view
30 of my improved packing-ring detached, and showing the lap-joints and their projecting tongues; and Fig. 4 is a plan of the lap-jointed ends of the ring, showing the projecting tongues, looking from the inner side of the
35 ring in cross-section.

A is the packing-ring, constituted of a yielding or elastic material—such as leather—which I find desirable to use when the ring is employed as a packing for the pistons of
40 rock-drills operated by compressed air. The ring is cut or split crosswise to form in it an edgewise lap-joint, as shown. This lap-joint is desirably formed in the manner shown in the drawings by notching or cutting away the
45 material of the ring on respectively opposite edges at the split, so as to constitute narrowed ends *a* and *a'*, adapted to overlap one another edgewise when brought together to form the joint. The lap-joint may be formed,
50 however, by an oblique cut or split in the

ring, or in any other suitable manner which will give a lap-joint which laps edgewise.

With the opposed ends, as at *a* and *a'*, constituting the edgewise lap-joint, I combine
55 the tongues B B, one on each of said ends. These tongues are of stiff or unyielding material, and are preferably formed of thin strips of leaf-spring steel of such a length that they extend backward from the lap-joint ends
60 along the inner face of the ring, whereto and to the inner face or under side of the lap-joint ends they may be secured by rivets passing through them and the material of the ring, as shown in Fig. 2. It is desirable that
65 the tongues be formed of spring-steel, as stated, as thereby they will possess a desired flexibility flatwise while being rigid or unyielding edgewise. The tongues preferably coincide in form and area to the respective
70 lap-joint ends to which they are attached. These tongues B B project each beyond the extremity of the lapping end *a a'*, to which they are mounted and reach across the split in the ring and along the inner face of the
75 opposite end of the ring, as shown in Fig. 3, and they are preferably given a curve flatwise conforming to the circle of the ring.

The packing-ring thus constructed is intended and adapted to be seated in the usual circumferential recess in a piston C, working
80 in a cylinder D, and with an expanding-ring E seated within it to expand it against the cylinder-wall, as shown in Figs. 1 and 2. When thus seated and the piston is in operation, the liability of the lap ends, as at *a a'*,
85 to escape or be drawn from the recess or be in any way disturbed in their seat in the recess, with the consequent result of injuring or destroying the lap-joint and rendering the packing ineffective or useless, is wholly prevented,
90 the tongues to which the respective lap ends are secured, and which pass under the opposite ends, respectively, of the ring-joint, serving to hold and maintain said ends in position lapped in the recess.

As the ring A is worn by friction it is capable of being expanded equally in all directions by the expanding-ring E, so as to maintain an accurate circle and preserve a tight
95 packing against the cylinder-wall, the tongues 100

B permitting the ring to expand freely and the lap-joint ends to move edgewise upon each other as the ring expands, as shown in Fig. 3, and at the same time serve to maintain the edgewise lap of said joint ends and consequently preserve the integrity of the packing at the lap-joint during the life of the ring.

It is desirable that the tongues B project beyond the extremities of the lap-joint ends *a a'* a distance equal at least to the length of the lap of said ends, as the lap-joint will be preserved and held securely in place by this means until the ring is so far expanded as to cause the extremities of the lap-joint ends to pass each other. The ring may then be easily and quickly removed from its seat in the recess and a new one inserted.

My improved packing-ring will be found effective in rock-drills in which there is a liability of the lap-joint ends of the packing-ring to catch in the cylinder-ports as the pis-

ton moves past them. My improved ring is comparatively inexpensive, readily manipulated, and capable of long service, which features are greatly to be desired in packing-rings for the pistons of rock-drills and analogous machines.

What I claim as my invention, and desire to secure by Letters Patent, is—

In a piston-packing ring of yielding material having an edgewise lap-joint, the combination, with the respective lap-joint ends, of tongues of stiff or unyielding material secured to and projecting one from the inner face of each of said ends beyond the extremities of said ends, and adapted to extend to and along the inner face of the ring across said joint, as specified.

ROBERT LUNNAN AMBROSE.

Witnesses:

SOLOMON LE FEVRE,
T. SHOANDERPLOIE.