

(19) **DANMARK**

(10)

**DK 180099 B1**



(12)

**PATENTSKRIFT**

Patent- og  
Varemærkestyrelsen

- 
- (51) Int.Cl.: ***E04D 13/03 (2006.01)*** ***B25H 7/00 (2006.01)***
- (21) Ansøgningsnummer: **PA 2018 70317**
- (22) Indleveringsdato: **2018-05-30**
- (24) Løbedag: **2018-05-30**
- (41) Alm. tilgængelig: **2019-12-01**
- (45) Patentets meddelelse bkg. og publiceret den: **2020-05-01**
- (73) Patenthaver:  
**VKR Holding A/S, Breelevej 18, 2970 Hørsholm, Danmark**
- (72) Opfinder:  
**Bent Atzen, c/o VKR Holding A/S Breelevej 18, 2970 Hørsholm, Danmark**  
**Jens-Ulrik Holst Henriksen, c/o VKR Holding A/S Breelevej 18, 2970 Hørsholm, Danmark**  
**Lars Erdmann, c/o VKR Holding A/S Breelevej 18, 2970 Hørsholm, Danmark**
- (74) Fuldmægtig:  
**AWA Denmark A/S, Strandgade 56, 1401 København K, Danmark**
- (54) Titel: **An installation aid adapted for use when mounting a window frame in a roof structure of a building, a kit including an installation aid, and a method for providing an installation aid**
- (56) Fremdragne publikationer:  
**EP 3043007 A1**  
**US 5613333 A**  
**US 2003/0217525 A1**  
**US 5195249 A**  
**FR 2048327 A5**  
**US 2014/0138429 A1**
- (57) Sammendrag:  
**An installation aid (1) adapted for use when mounting a window frame in a roof structure is disclosed. It comprises a plate portion (2) adapted for being arranged on an exterior side of the roof structure, so that it extends in parallel with the plane of the roof structure and matching the size and shape of the window frame. The plate portion (2) is provided with at least one pre-defined fold-line (21) and at least one first cut-out (271) intended for use as a handle, so that when the plate portion (2) is folded a space suitable for enclosing in-sulating and/or weather-proofing element(s) (3) if formed between two sections of the plate portion (2). In a preferred embodiment at least two first cut-outs (271) become superposed in a folded state of the plate portion (2) in a manner allowing these first cut-outs (271) to be used as a single handle. A method for providing an installation aid (1) is also disclosed.**

Fortsættes...

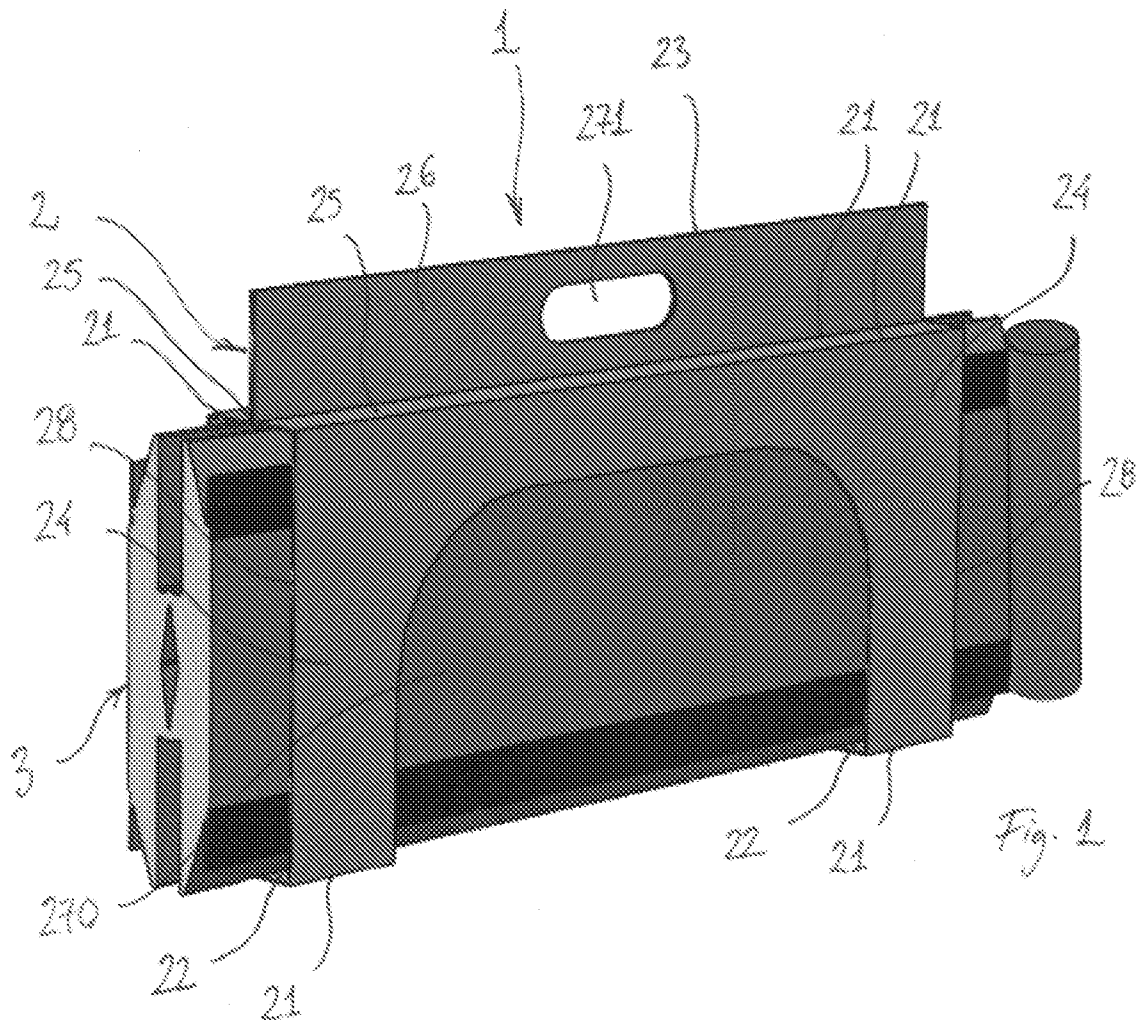

The present invention relates to an installation aid adapted for use when mounting a window frame in a roof structure of a building, to a kit including such an installation aid, and to a method for providing an installation aid for use when mounting a window frame in a roof structure of a building.

5 In EP3043007A1 an installation aid is presented, the presented installation aid is a sheet material template suitable for facilitating attachment of building panels to a supporting structure and/or for covering a stack of building panels.

When the installing a window in an inclined roof including an under-  
10 roof, an opening for the window frame is cut in roof battens and the underroof. An insulating frame adapted to surround the window frame and insulate the transition between the roof window and the roof structure in the mounted state may be used for marking where the cut in the roof structure should be made as described in WO9831896A1. This method, however, suffers from  
15 the disadvantages that the insulating frame may be difficult to handle, particularly if performing the installation on a windy day, and that some insulating frames have a tendency to warp resulting in the opening getting the wrong shape.

When the window frame, and possibly an insulating frame, has been  
20 mounted in the opening, a sealing collar also known as an underroof collar is applied in order to waterproof the transition between the installed window frame and the underroof. Such an underroof collar is known from EP0994992B1. During the installation, the underroof collar is pulled over the window frame and an inner portion of the underroof collar is attached to the  
25 outer side of the window frame so that an outer skirt portion of the underroof collar extends over the underroof of the roof structure. Subsequently flashing elements are arranged on top of the underroof collar.

This way of weather-proofing the transition between a window frame and a roof structure has found widespread use and has proven to work very  
30 well as long as the installation is performed correctly. However, the underroof collar, which is typically made from a thin water- and wind-proof non-woven material, is prone to fluttering under the influence of wind, and is therefore not

always installed with the necessary precision.

Moreover, it remains a problem that a relatively high number of installation products have to be handled during the installation process.

It is therefore the object of the invention to provide an installation aid,  
5 which facilitates the installation of a roof window.

In a first aspect of the invention this is achieved with an installation aid comprising a plate portion adapted for being arranged on an exterior side of the roof structure, so that it extends in parallel with the plane of the roof structure, said plate portion matching the size and shape of the window  
10 frame, where the plate portion is provided with at least one pre-defined fold-line and at least one first cut-out at a distance from the at least one fold-line and at an outer edge of the plate portion, said first cut-out being suitable for use as a handle and said fold-line allowing the installation aid to be folded in a manner so that a space is formed between two sections of the plate portion.

15 By allowing the installation aid to be folded and providing the plate portion it with a cut-out suitable for use as a handle, the installation aid gets down to a manageable size and the handle in the relatively stiff plate portion allows it to be easily carried onto the roof, where it is to be used. The space allows the installation aid to serve as a carrier bag for the other installation  
20 products to be used in the installation of the roof window, thus allowing them all to be carried onto the roof as one convenient item.

When it is to be used for aiding in the mounting a window frame in a roof structure of a building, the installation aid is unfolded and arranged with the plate portion on an exterior side of the roof structure, where it may be  
25 used as an aid for cutting the opening in the roof structure and/or for forming part of the weather-proofing system as will be described below. Installation products held in the space of the installation aid in the folded state may be removed before arranging the plate portion in plane with the roof structure, but it is also possible to have some of them permanently attached to the plate  
30 portion.

The term "cut-out" is to be understood as an interruption of the sheet material used for the plate portion. It will often be advantageous to make it by

cutting or punching, but it is not to be understood as being limited to such methods. It is also possible to provide the cut-out by moulding, by melting the material, or by any other method suitable for locally interrupting the material. It is noted that it is not necessary to remove material. It is also possible to fold  
5 away a flap of material, which has been loosened from the plate portion. Folding away material may help to stabilize the opening and/or make the edge of the opening less sharp.

If providing more than one fold-line, the folded installation aid may be given a more complex shape. In one embodiment, two fold-lines are provided  
10 close to the middle of the plate portion, so that in the folded state of the installation aid the section between these fold-lines forms a base section on which the installation aid may rest in a standing position. In another embodiment six fold-lines are provide so that a base section is formed between the two fold-lines furthest from the outer edges of the plate portion and so that a substan-  
15 tially rectangular space is formed between the two sections adjacent to the base sections.

The plate portion makes the installation aid substantially more dimensionally stable than the traditional insulating frames, making it well suited as a guide for making the opening in the roof. For this purpose, the plate por-  
20 tion may have outer dimensions matching the dimensions of the window frame, so that cut made along the outer edges of the plate portion or along lines drawn with these edges as a drawing guide results in an opening matching the size and shape of the window frame. It is, however also possible to provide the plate portion with one or more second cut-outs forming inner edg-  
25 es of the plate portion, which are arranged so that they match the outer dimensions of the window frame and may thus be used as drawing or cutting guides. In other words, the feature that the plate portion is matching the size and shape of the window frame is not intended to limit the scope of the claims to embodiments, where the outer dimensions of the plate portion correspond  
30 to the outer dimensions of the window frame. It is even feasible to provide the plate portion with second cut-outs allowing one installation aid to be used in the mounting of two or more different dimensions of the window frame, and/or

to use the outer edges of the installation aid for one window frame size and inner edges for one or more other window frame sizes.

Alternatively, or in addition, the plate portion may replace or support the inner portion of the underroof collar thus making the water-proofing of the transition between the window frame and the roof structure easier than with a  
5 traditional underroof collar.

In one embodiment, the plate portion comprises at least two first cut-outs and the fold-line(s) is/are located so that two first cut-outs located at two opposing outer edges of the plate portion become superposed in a folded  
10 state of the installation aid in a manner allowing these first cut-outs to be used as a single handle. This has at least two advantages. One being that the double layer of material provides a relatively more stable handle, another being that holding on to both of these cut-outs at the same contributes to retaining the plate portion in its folded state and retaining items held in the space de-  
15 limited by the plate portion.

In a second aspect of the invention the object is achieved with a kit including an installation aid as described above and at least one insulating and/or weather-proofing element, said installation aid being folded around the insulating and/or weather-proofing element(s) in a state of delivery so that the  
20 insulating and/or weather-proofing element are enclosed in a space between two sections of the plate portion. This allows the installation aid and the insulating and/or weather-proofing elements to be delivered and handled as one convenient item.

The at least one insulating and/or weather-proofing element may for  
25 example include insulating elements adapted for being interconnected to form an insulating frame surrounding the window frame in the mounted state, flashing members, and/or a skirt member adapted to serve the same purpose as the outer skirt portion of a traditional underroof collar. Other items such as coverings, claddings, fasteners, brackets etc. may also be provided on the  
30 plate portion.

In one embodiment, all insulating elements needed for insulating the transition between the roof structure and the window frame and possible as-

sociated items, such as connectors, are held by the folded installation aid. It is presently considered advantageous that at least one of them is attached to the installation aid, for example by means of an adhesive, in order to prevent them from being lost. It is, however, also possible to compress the insulating  
5 element(s) when folding the installation aid, such that it/they are kept in place by friction. In that case, the opposite sides of the installation aid, which come together as a result of the folding, should preferably be attached to each other, for example by means of staples, in order to make sure that the installation aid does not unfold as a result of the pressure from the compressed insulating  
10 element(s).

The kit may further include a roof window so that it is ensured that the installer get the roof window and the installation aid with matching shapes and sizes.

In a third aspect of the invention the object is achieved with a method, comprising:  
15

providing an installation aid comprising a plate portion adapted for being arranged on an exterior side of the roof structure, so that it extends in parallel with the plane of the roof structure, said plate portion matching the size and shape of the window frame to be mounted,

20 arranging at least one insulating and/or weather-proofing element on the plate portion, possibly attaching one or more insulating and/or weather-proofing elements to the plate portion,

folding said plate portion along at least one pre-defined fold-line so that the insulating and/or weather-proofing element(s) become enclosed in a space formed between two sections of the plate portion, thereby bringing the  
25 installation aid into a folded state, and

using at least one first cut-out provided at a distance from the at least one fold-line and at an outer edge of the plate portion as a handle when handling the installation in its folded state.

30 This method results in the installation aid being provided in an easily manageable folded state of delivery as also described above.

In a preferred embodiment, the plate portion comprises at least two

first cut-outs and where the plate portion is folded so that two first cut-outs located at two opposing outer edges of the plate portion become superposed in a manner allowing these first cut-outs to be used as a single handle.

When at the installation site the use of the installation aid includes  
5 unfolding the installation aid, arranging the plate portion on an exterior side of the roof structure, attaching the plate portion to the roof structure, and using the plate portion as an aid for cutting an opening in the roof structure and/or for transferring a cutting indication to the roof structure.

Embodiments and advantages of the invention described with refer-  
10 ence to one aspect of the invention also applies to the other aspect unless otherwise stated.

The following embodiments are common to all aspects of the inven-  
tion.

In one embodiment, the first cut-out(s) has/have an elongate rounded  
15 shape with a length of at least 40 mm, preferably between 90 mm and 120 mm, and a width of at least 15 mm, preferably between 20 mm and 50 mm. These dimensions make the first cut-outs well-suited for being gripped by a human using two or more fingers and the rounded shape facilitates gripping.

As mentioned above, the installation aid may comprise at least one  
20 second cut-out adapted for assisting in forming an opening in the roof structure suitable for receiving the window frame. The second cut-out may be a large cut-out corresponding in size and shape to the size and shape of the intended opening in the roof structure and thus also to the outer dimensions of the roof window frame to be mounted therein. It may, however, be pre-  
25 ferred to use a plate portion, which at least partially covers the intended opening in the roof structure when arranged in plane with the roof, since this will make the installation aid more dimensionally stable and provide a larger surface suitable for carrying insulating elements and other items. A series of second cut-outs can then be provided forming a path along the intended edge  
30 of the opening in the roof structure. This series of second cut-outs can then be used as a cutting guide when making the opening in the roof structure or as a drawing guide allowing the shape of the intended opening to be trans-



ferred to the roof structure using a pen or the like.

If the second cut-out is a large cut-out corresponding in size and shape to the size and shape of the intended opening in the roof structure, a stabilizing member may be arranged in the second cut-out interconnecting the edges of the second cut-out. This will help prevent the plate portion from unintentional warping. Such a stabilizing portion may for example be attached to the plate portion by means of an adhesive, welding, staples, or friction.

The plate portion will typically include material, which in the mounted condition constitutes a top, a bottom and two side members. It is, however also possible to utilize a plate portion not extending along all sides of the opening in the roof structure, or to use a plate with no clear distinction between top, bottom and two side members.

In one embodiment, the plate portion is assembled from four or more separate pieces of material. This allows an overlap at the corners which may strengthen and/or stabilize the plate portion. It also allows the separate pieces of material to be made from different materials. One or more of the separate pieces may be made by extrusion or a like continuous process, which may reduce the cost of manufacture. Separate frame pieces may be assembled on site.

The plate portion is preferably made of relatively rigid material in order to facilitate handling. Cardboard is one option, but it may be preferred to use a polymer, such as for example polypropylene, polyethylene, or polyvinylchloride, due to its resistance to moisture. Composites and layered materials such as polymer coated cardboard are also usable.

Using a transparent material will allow the installer to see the battens and other parts of the roof structure underneath the plate portion, when the installation aid has been arranged on an exterior side of the roof structure, thus potentially facilitating the installation process. Another potential advantage of using a transparent material is that insulating and/or weatherproofing elements held within the space formed by the folded installation aid can be more easily identified.

At least one third cut-out may be provided for holding a tool or another

er product during installation of the installation aid and/or the window frame. Such cut-outs are preferably embodied by leaving a flap of material, which can be folded outwards from the plane of the plate portion, and which is then used as a shelf for carrying the tool or other product. When no longer needed  
5 the flap can be moved back into the cut-out to lie flush with the plate portion.

One example is the provision of two cut-outs at the side of the installation aid intended to be arranged at the bottom of the opening in the roof structure, i.e. horizontally and lowermost when seen in the direction of slope of the roof. When folding the flaps loosened by the cut-outs, so that they project towards the exterior, these flaps can be used for supporting a spirit level,  
10 thus helping to ensure a correct positioning of the unfolded installation aid in relation to the roof structure. This is particularly advantageous when using the installation aid as an aid for making the opening in the roof structure.

Such flaps may also be used for positioning insulating and/or weather-proofing elements or other items in relation to the plate portion in the folded  
15 state of the installation aid.

Similarly, at least one fourth cut-out can be used for positioning the installation aid in relation to the roof structure and/or for attaching the installation aid to the roof by turning flaps of material loosened by the cut-out inwards  
20 so that they engage with the inner sides of the battens, installation battens, or other parts of the roof structure. Such flaps of material may also serve weather-proofing purposes by contributing to a wind-proofing of the finished structure. Flaps projecting from fourth cut-outs may also be used for supporting an installation batten, drainage gutter, or tile support, either permanently or temporarily until it has been attached to the roof structure.  
25

Other possible types of cut-outs are at least one fifth cut-out adapted for connecting the installation aid to another installation aid and/or at least one sixth cut-out adapted for assisting in reducing the size of the installation aid. The fifth cut-outs may give the outer edges of the plate portion the shape  
30 of pieces of a puzzle, or cut-out flaps on one plate portion may be folded out and passed through openings in another plate portion, thereby locking the two plate portions to each other. The sixth cut-outs may serve as cutting guides or

serve as weakenings allowing a separation of two parts of the plate portion. These embodiments allow the installation aid to be adapted for situations, where two or more roof windows are installed close to each other, or where a roof window is installed close to another structure, such as a chimney, a wall,  
5 or a solar collector.

User instructions can be printed on the plate portion, both regarding how to install the installation aid itself and regarding possible other items held inside it in the state of delivery. Other information regarding origin, size, type, etc. of the installation aid may also be provided on the plate portion.

10 In order to replace or supplement a traditional underroof collar, the installation aid may include a skirt portion attached to an outer edge of the plate portion. In the state of the delivery, the skirt portion is preferably rolled-up or folded so that it can be positioned between two sections of the plate portion as described above.

15 As will be understood by the skilled person, the advantages described with reference to the different cut-outs above and in the following are independent of each other. This means that the advantages described with reference to second, third, fourth, fifth, and sixth cut-outs will still apply even if the installation aid does not have first cut-outs suitable for use as handles.  
20 Likewise, even if some of the cut-outs may have a combined function, one should not be regarded as a necessity if applying another.

In the following the invention will be described in more detail with reference to the drawing, where

25 Fig. 1 shows a perspective view of an installation aid according to the invention in a folded state of delivery,

Fig. 2 shows a different embodiment of the installation aid in a folded state and being carried by an installer,

Fig. 3 shows the installation aid in Fig. 2 in an unfolded state,

30 Fig. 4 shows a third embodiment of an installation aid according to the invention in an unfolded state and arranged on a roof structure,

Fig. 5 shows a fourth embodiment of an installation aid according to the invention in an unfolded state and arranged on a roof structure,

Fig. 6 shows a spirit level arranged on flaps folded out from cut-outs in a fifth embodiment of an installation aid according to the invention in an unfolded state,

Fig. 7 shows the interconnection of a sixth embodiment of installation aids arranged in a group,

Fig. 8 shows the detail marked VIII in Fig. 7,

Fig. 9 shows the detail marked IX in Fig. 7,

Fig. 10 corresponds to Fig. 9 but showing an installation situation where the roof windows are to be mounted with a shorter horizontal distance,

Fig. 11 corresponds to Fig. 7 but showing a seventh embodiment of installation aids, and

Fig. 12 shows the detail marked XII in Fig. 11.

An installation aid 1 according to the invention is shown in a folded state in Fig. 1.

The plate portion 2 is here folded along six fold-lines 21 of which only five can be seen. These fold-lines 21 are parallel and arranged substantially symmetrically in relation to the centre of the plate portion, and the plate portion has been folded over 90 degrees at each of the fold-lines. A two-part base section 22 is defined between the two lines furthest from the outer edges 23 of the plate portion, and two side sections 24, one on either side of the base section, extend away from the base section substantially in parallel to each other. Two top sections 25 in continuation of the side sections extend towards each other substantially in parallel with the base section, and two handle sections 26 closest to the outer edges 23 of the plate portion extend away from the base section substantially in parallel with the side sections. In this way a substantially rectangular space has been formed between the base section 22, the two side sections 24, and the top sections 25, while the handle sections 26 are aligned and lying closely together.

The space formed between the base section 22, the two side sections 24, and the top sections 25 encloses a plurality of insulating and weather-proofing elements 3, and each of the handle sections 26 includes a first cut-out 271 suitable for use as a handle. As the handled sections are parallel

and adjacent to each other the two first cut-outs together form a single handle.

Here the first cut-outs 271 are shown as simple openings in the material of the plate portion, but it will be understood that it is also possible to  
5 leave a section of the material, for example a flap having substantially the same shape as the opening, and fold it over the edge of the opposite cut-out. The flap on one handle section projecting through the opening in the other handle section will not only result in a reduced risk of cutting one's fingers on the edges of the cut-outs but will also contribute to keeping the two handle  
10 sections 26 in a closely aligned mutual position. These advantages will also apply to other embodiments with two superposed cut-outs.

In another embodiment, which is not illustrated, the plate portion has only one handle section. The other is either replaced by a flap, which is attached to the one handle section, or it is left out entirely and the two top sections are connected directly to each other.  
15

The reference numbers used in Fig. 1 will also be used in the following figures for features having substantially the same function, even though they are not necessarily identical. Throughout the drawing the same reference numbers have been used for features having substantially the same  
20 function.

Another embodiment of the installation aid 1 is shown in Figs 2 and 3. In Fig. 2 it is being carried by an installer 4 and in Fig. 3 it is in its unfolded state.

In this embodiment the plate portion 2 includes only two fold-lines 21  
25 delimiting two base sections 22, one on either side of a central opening 270. This means that in the folded state, the two handle sections 26 do not lie flush but only come together at the part closest to the outer edges 23. In this embodiment the plate portion encloses a considerably number of insulating and weather-proofing elements in its folded state and the handle sections are therefore curving. Staples, adhesive or the like applied at the outer edges 23  
30 may be used to keep the two handles sections 26 together. Here too, it is possible to replace one of the handle sections with a flap or connect the side

section directly to the handle section on the opposite side at a position below the first cut-out when seen in the state and orientation shown in Fig. 2.

As will be seen in Fig. 2, the folding of the plate portion 2 has resulted in the installation aid getting down to a size, where it is easily manageable, so that the installer 4 can conveniently carry it onto the roof of a building (not shown), and the insulating and weather-proofing elements 3 are conveniently kept in place. The insulating and weather-proofing elements have been attached to the plate portion by an adhesive (not shown) before folding the plate portion so that they do not slide out.

A company logo has been printed on the plate portion 2 and it is also possible to print or attach other information, such as for example user instructions on the plate portion. Logo or information can also be applied to the side of the plate portion forming the interior side in the folded state. This possibility for adding information to the plate portion applies to all embodiments of the invention.

A third embodiment of an installation aid is shown in Fig. 4, where the unfolded plate portion 2 has been arranged on an exterior side of a roof structure 5 including roofing 51, underroof 52, battens 53, and counter-battens 54 arranged on top of rafters (not shown), so that the plate portion extends in parallel with the plane of the roof structure. The central opening 270 is aligned with an opening 50 formed in the roof structure so that an installer (not shown) can stand inside the building with his upper body and arms on the outside of the opening and be able to reach the entire installation aid and surrounding parts of the roof structure.

When mounting a window frame in the roof structure 5 using this embodiment of the installation aid, the following sequence of steps is performed:

- Forming a preliminary opening 50 in the roof structure.
- Arranging an installation batten 55 at a position defining the position of the bottom of the window frame in the mounted state.
- Bending flaps formed by cut-outs 274 in the plate portion 2 of the installation aid 1 inwards and arranging the plate portion on top of the battens 53

so that two of the flaps rest on the installation batten 55 thereby positioning the plate portion in the direction of inclination of the roof. It is also possible to first arrange the plate portion and then bend the flaps to keep it in place.

- 5
- Attaching the plate portion 2 to the battens 53 and/or installation batten 55, for example by means of staples.
  - Possibly arranging a second installation batten 56, drainage gutter, or tile support by using two other flaps bent out from cut-outs 274 in the plate portion as a support.
- 10
- Using the outer edges 28 extending in parallel with the direction of inclination of the roof structure 5 as drawing aids for transferring a cutting indication to at least the battens.
  - Removing the installation aid 1 and using the just made cutting indications on the battens 53 as a guide for cutting a permanent opening in the
- 15

As an alternative to the last two steps, it is also possible to simply use the outer edges 28 of the plate portion 2 as cutting guides advancing a jigsaw or the like (not shown) along these outer edges, and then subsequently removing the installation aid.

- 20
- The parts of the plate portion 2 located on top of the installation battens 55, 56, i.e. outside the limits of the permanent opening in the roof structure, can be left on the roof structure 5 by cutting along the lines indicated by a second cut-out 272. These second cut-outs are sufficiently big to allow the blade of a jigsaw to pass through one of them and the other second cut-outs
- 25
- in the line will then guide the saw.

A fourth embodiment of the installation aid is shown in Fig. 5.

- This installation aid is provided with second cut-outs 272 not only at the top and bottom as in Fig.4 but also along the outer edges 28 extending in parallel with the direction of inclination of the roof. These second cut-outs are
- 30
- well suited for assisting in the formation of the opening in the roof structure by serving as drawing or cutting guides as is here illustrated by a saw 6.

In this embodiment the parts of the plate portion 2 left after cutting

out the opening in the roof structure forms a frame surrounding the opening. This frame may serve as a sealing frame surrounding the window frame (not shown) when it has been mounted and contributing to the weather-proofing of the finished structure. The part which is shown in grey and is removed when  
5 cutting the opening may be made from a different material than the rest of the plate portion and serve as a temporary stabilizing portion.

Furthermore, the plate portion 2 here serves as a point of attachment for an outer skirt portion 7 serving as an underroof collar, the plate portion thus replacing the inner un-pleated portion known from some traditional un-  
10 derroof collars. The attachment of the skirt portion or underroof collar 7 to an outer portion of the plate portion 2 at line 71 may be established as a part of the mounting process, or the underroof collar may be attached already in the state of delivery and kept enclosed in the plate portion 2 in the folded state as previously described with reference to insulating and weather-proofing ele-  
15 ments.

A still further embodiment is shown in Fig. 6. In addition to a central opening 270 and to second-cut-outs 272 adapted for assisting in forming an opening in the roof structure suitable for receiving the window frame, the plate portion 2 here also includes two third cut-out 273 from where flaps have been  
20 bent out and are holding a spirit level 8. Such flaps can also be used for holding other tools or products associated with the installation of a roof window and the openings formed by the cut-outs may also be utilized for such purposes.

In this embodiment the first cut-outs 271 are of a rectangular shape,  
25 whereas they are rounded in the other figures of the drawing.

Turning now to Figs 7-12 these show still further embodiments adapted for use when mounting two or more window frames in a group, here four windows (not shown) mounted two-by-two, i.e. side-by-side and over-  
and-under. In order to achieve the prescribed distance between the roof win-  
30 dows in the group, the installation aids 1 also need to be arranged correctly in relation to each other. Their dimensions are therefore such that a standard installation distance is achieved by abutting the outer edges 23, 28 of the



plate portions 2 so that the plate portions lie as close to each other as possible without overlapping. In the situation shown in Fig. 7, however, a shorter distance between the roof windows in the direction of the inclination of the roof is required and the plate portions are therefore arranged with an overlap  
5 as is better seen in Fig. 8. In this embodiment, the mutual position of the plate portions is ensured by means of a connector bracket 9 being inserted with each of its two legs through fifth cut-outs 275 in the respective plate portions. As can be seen, a second set of fifth cut-outs, here shown as holes, is provided for use if a shorter overlap is needed.

10 Figs 9 and 10 show how the outer edges 28 extending in the direction of the inclination of the roof can either abut as in Fig. 7 and 9 or overlap as in Fig. 8 and 10 and how the connector bracket 9 and the fifth cut-outs 275 can be used for fixating either of these mutual position as well as at least one further mutual position by passing the connector bracket through other cut-  
15 outs.

Fig. 11 and 12 show a different embodiment of the installation aids 1 having many of the features described with reference to the previous embodiments as indicated by the reference numbers. In this embodiment the first cut-outs 271 are arranged at the outer edges 28 extending in the direction of  
20 the inclination of the roof in the mounted state and only a single fold-line 21 is used.

This embodiment too has fifth cut-outs 275 adapted for connecting one installation aid to another installation aid, but in this embodiment the interconnection is achieved by bending a flap 279 formed in one of the cut-outs  
25 275 through a cut-out 275 in the other installation aid, i.e. without any loose connector brackets. The flap 279 is provided with an arrow and the respective cut-outs 275 in the receiving plate portion with size indications, here the numbers 100, 120, 140, 160, helping the installer to choose which cut-out to pass the flap through in order to have the correct distance between the central  
30 openings 270 in the two installation aids. The numbers 100, 120, 140, 160 each indicates a distance in millimetres between the window frames so that standard flashing and covering members may be used.

If it is desired to avoid overlapping plate portions, the plate portion 2 may instead or as supplement be provided with at least one sixth cut-out 276 adapted for assisting in reducing the size of the installation aid 1. Such sixth cut-outs 276 are seen in Fig. 3, where two series of elongate cut-outs on both sides of the plate portion serve as guides for reducing the width of the plate portion to two different smaller sizes, but it is of course also possible to remove material only at one side. The triangular cut-outs are intended as size indicators and explanatory text can be printed or attached next to them. Alternatively, the triangular openings can be made with different sizes of shapes or left out.

A need for reducing the size of the installation aid 1 may also arise from differences in other installation conditions such as the possible use of an insulating frame. As an example the size and shape of the plate portion 2 may correspond to the size and shape of a standard size insulating frame, while sixth cut-outs 276 or other size reduction aids allow the plate portion 2 to be reduced to a size corresponding to the window frame without an insulating frame. Likewise, sixth cut-outs 276 or other size reduction aids allowing the plate portion 2 to be reduced to a size corresponding to smaller or reduced insulating frame may be provided, which may for example be relevant if installing a window in a roof where the position and/or distance between rafters does not allow the use of a standard insulating frame.

The exact design of the sixth cut-outs may vary and it is also possible to indicate a possible size reduction without cut-out, simply adding lines, text, colouring, or the like to the plate portion.

The installation aids 1 in Figs 7-10 are adapted either for being arranged in alignment with a pre-made opening in the roof structure, or for using the edge of the central opening 270 as a drawing or cutting guide, while the installation guides in Figs 11-12 have a temporary stabilizing portion as described with reference to Fig. 5. It is to be understood that unless otherwise stated the fifth cut-outs 275 are independent both on these features and on other features such as for example the position of the first cut-outs. This is just one example which illustrates the general rule that the functionally inde-

pendent features of the embodiments described above are not to be regarded as depending on each other. I.e. the presence of one does not mean that the other has to be present too in order for the installation aid to fall within the scope of the claims unless explicitly disclosed.

## P A T E N T C L A I M S

1. Installationshjælpemiddel (1) indrettet til brug ved montering af en vindueskarm i en tagkonstruktion af en bygning, hvor installationshjælpemid-  
let (1) omfatter en pladedel (2) indrettet til at blive anbragt på en udvendig  
5 side af tagkonstruktionen, så den strækker sig parallelt med planet af tagkon-  
struktionen, hvor pladedelen (2) er tilvejebragt med mindst en foruddefineret  
foldelinje (21) og mindst én første udskæring (271) i en afstand fra den mindst  
ene foldelinje (21) og ved en ydre kant (23, 28) af pladedelen (2), hvor den  
første udskæring (271) er egnet til brug som et håndtag, og foldelinjen (21)  
10 tillader, at installationshjælpemidlet (1) kan foldes på en måde, så der dannes  
et mellemrum mellem to sektioner af pladedelen (2), k e n d e t e g n e t ved,  
at pladedelen (2) matcher størrelsen og formen på vindueskarmen og installa-  
tionshjælpemidlet (1) yderligere omfatter mindst én tredje udskæring (273) til  
at holde et værktøj eller et andet produkt under installation af installations-  
15 hjælpemidlet (1) og/eller vindueskarmen.

2. Installationshjælpemiddel (1) ifølge krav 1, hvor pladedelen (2)  
omfatter mindst to første udskæringer (271), og hvor foldelinjen/foldelinjerne  
(21) er placeret således, at de to første udskæringer (271) placeret ved to  
modstående ydre kanter (23, 28) af pladedelen (2) bliver overlejret i en foldet  
20 tilstand af installationshjælpemidlet (1) på en måde, der tillader at disse første  
udskæringer (271) bruges som et enkelt håndtag.

3. Installationshjælpemiddel (1) ifølge et eller flere af de foregående  
krav, hvor de(n) første udskæring(er) (271) har en langstrakt afrundet form  
med en længde på mindst 40 mm, fortrinsvis mellem 90 mm og 120 mm og  
25 en bredde på mindst 15 mm, fortrinsvis mellem 20 mm og 50 mm.

4. Installationshjælpemiddel (1) ifølge et eller flere af de foregående  
krav, der yderligere omfatter mindst én anden udskæring (272) indrettet til at  
hjælpe med at danne en åbning i tagkonstruktionen, der er egnet til at modta-  
ge vindueskarmen.

30 5. Installationshjælpemiddel (1) ifølge et eller flere af de foregående  
krav, som yderligere omfatter mindst én fjerde udskæring til at placere instal-  
lationshjælpemidlet (1) i forhold til tagkonstruktionen og/eller til at fastgøre  
installationshjælpemidlet (1) til tagkonstruktionen.

6. Installationshjælpemiddel (1) ifølge et eller flere af de foregående krav, der yderligere omfatter mindst én femte udskæring (275) indrettet til at forbinde installationshjælpemidlet (1) til et andet installationshjælpemiddel og/eller mindst én sjette udskæring (276) indrettet til at hjælpe med at reducere størrelsen på installationshjælpemidlet (1).

7. Installationshjælpemiddel (1) ifølge et eller flere af de foregående krav, hvor én eller flere udskæringer (271, 272, 273, 274, 275, 276) efterlader en flap af materiale, der kan foldes udad fra planet af pladedelen (2).

8. Installationshjælpemiddel (1) ifølge et eller flere af de foregående krav, hvor brugerinstruktioner er trykt på pladedelen (2).

9. Installationshjælpemiddel (1) ifølge et eller flere af de foregående krav, som yderligere indbefatter en ydre skørtedel (7) fastgjort til en ydre del af pladedelen (2).

10. Kit, der indbefatter et installationshjælpemiddel (1) ifølge et eller flere af de foregående krav og mindst ét isolerende og/eller vejrbeskyttelses-element (3), hvor installationshjælpemidlet (1) er foldet omkring isolerings- og/eller vejrbeskyttelseselementet/vejrbeskyttelseselementerne (3) i en leveringstilstand.

11. Kit ifølge krav 10, der yderligere indbefatter et tagvindue med en karm, der har en størrelse og form, der matcher størrelsen og formen af pladedelen (2).

12. Fremgangsmåde til tilvejebringelse af et installationshjælpemiddel (1) til brug ved montering af en vindueskarm i en tagkonstruktion af en bygning, omfattende:

25 at tilvejebringe et installationshjælpemiddel (1), som omfatter en pladedel (2) indrettet til at være anbragt på en udvendig side af tagkonstruktionen, så den strækker sig parallelt med planet af tagkonstruktionen, hvor pladedelen (2) matcher størrelsen og formen af vindueskarmen,

30 at anbringe mindst ét isolerings- og/eller vejrbeskyttelseselement (3) på pladedelen (2), eventuelt at fastgøre ét eller flere isolerings- og/eller vejrbeskyttelses-elementer (3) til pladedelen (2),

at folde pladedelen (2) langs mindst én foruddefineret foldelinje (21),

således at isolerings- og/eller vejrbeskyttelses-elementet /vejrbeskyttelseselementerne (3) bliver lukket inde i et rum dannet mellem to sektioner af pladedelen (2), hvorved installationshjælpemidlet (1) bringes i en foldet tilstand, og

5 at anvende mindst én første udskæring (271) tilvejebragt i en afstand fra den mindst ene foldelinje (21) og ved en ydre kant (23, 28) af pladedelen (2) som et håndtag ved håndtering af installationshjælpemidlet i sin foldede tilstand.

13. Fremgangsmåde ifølge krav 12, hvor pladedelen (2) omfatter  
10 mindst to første udskæringer (271), og hvor pladedelen (2) er foldet således, at to første udskæringer (271), der er placeret ved to modstående ydre kanter (23, 28) af pladedelen (2), bliver overlejret på en måde, der tillader, at disse første udskæringer (271) kan bruges som et enkelt håndtag.

14. Fremgangsmåde ifølge krav 12 eller 13, som yderligere indbefat-  
15 ter at

udfolde installationshjælpemidlet (1),  
anbringe pladedelen (2) på en udvendig side af tagkonstruktionen,  
fastgøre pladedelen (2) til tagkonstruktionen, og  
anvende pladedelen (2) som et hjælpemiddel til at skære en åbning i  
20 tagkonstruktionen og/eller til at overføre en skæreindikation til tagkonstruktionen.

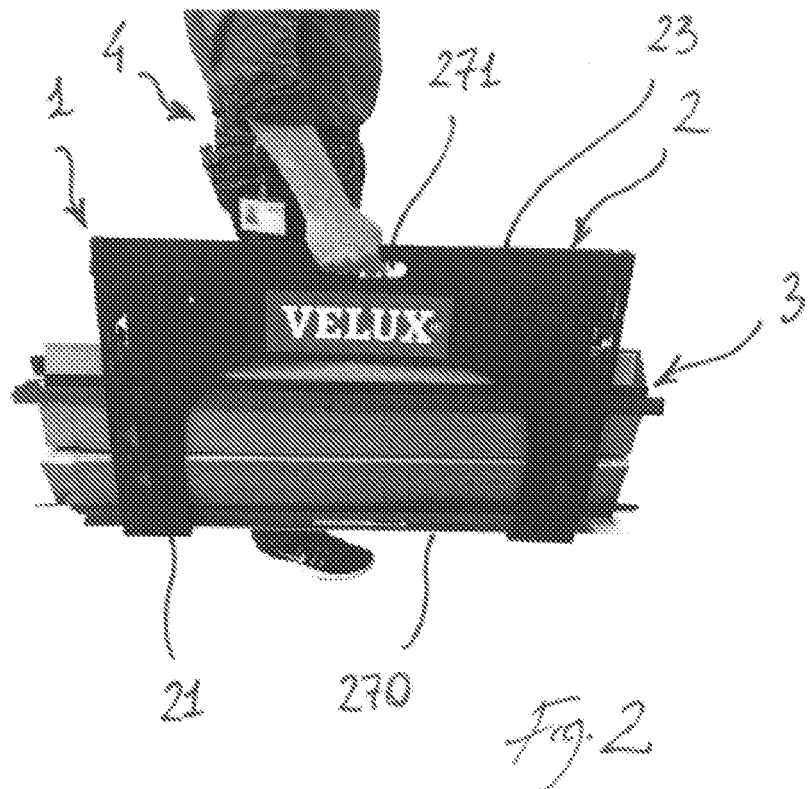
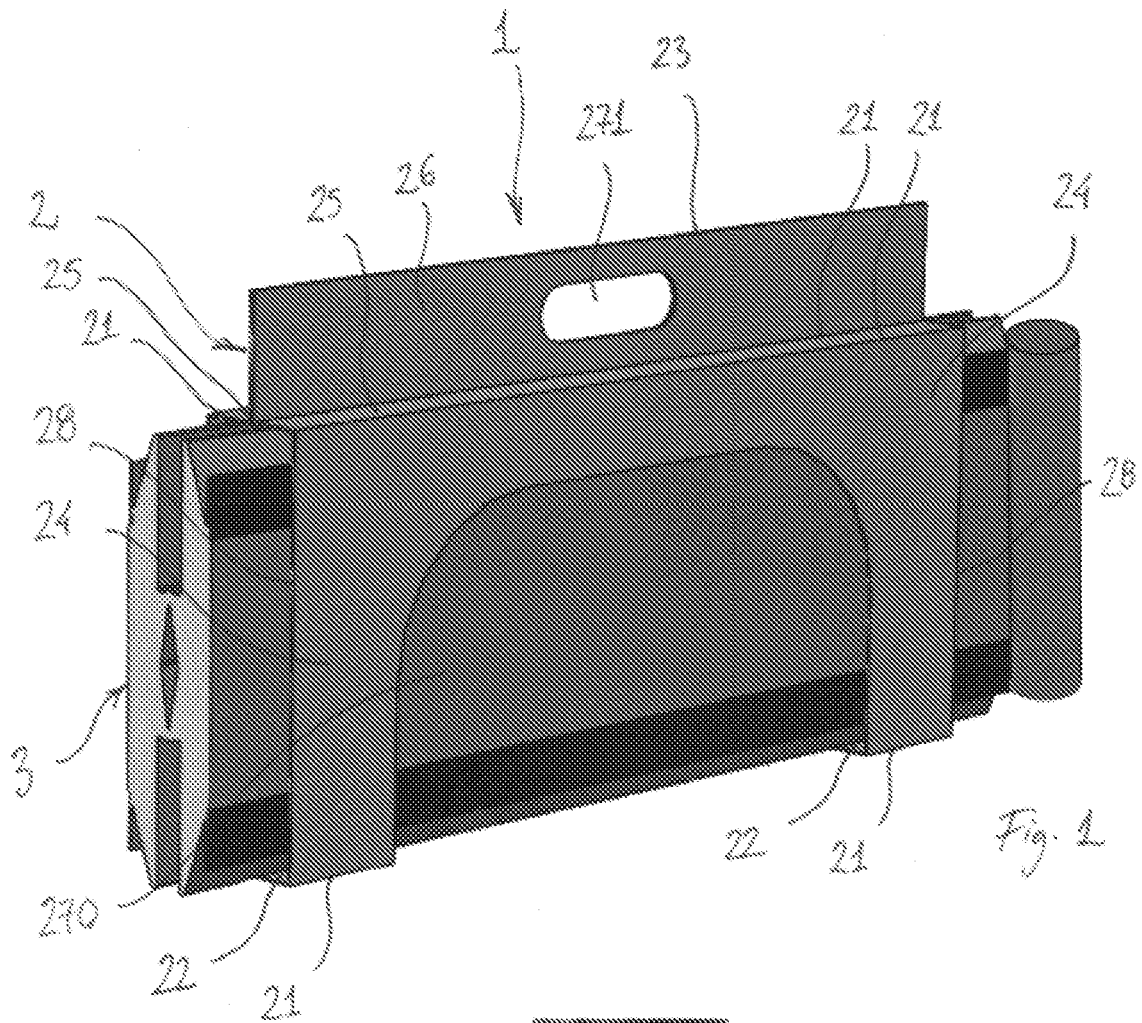

2/6

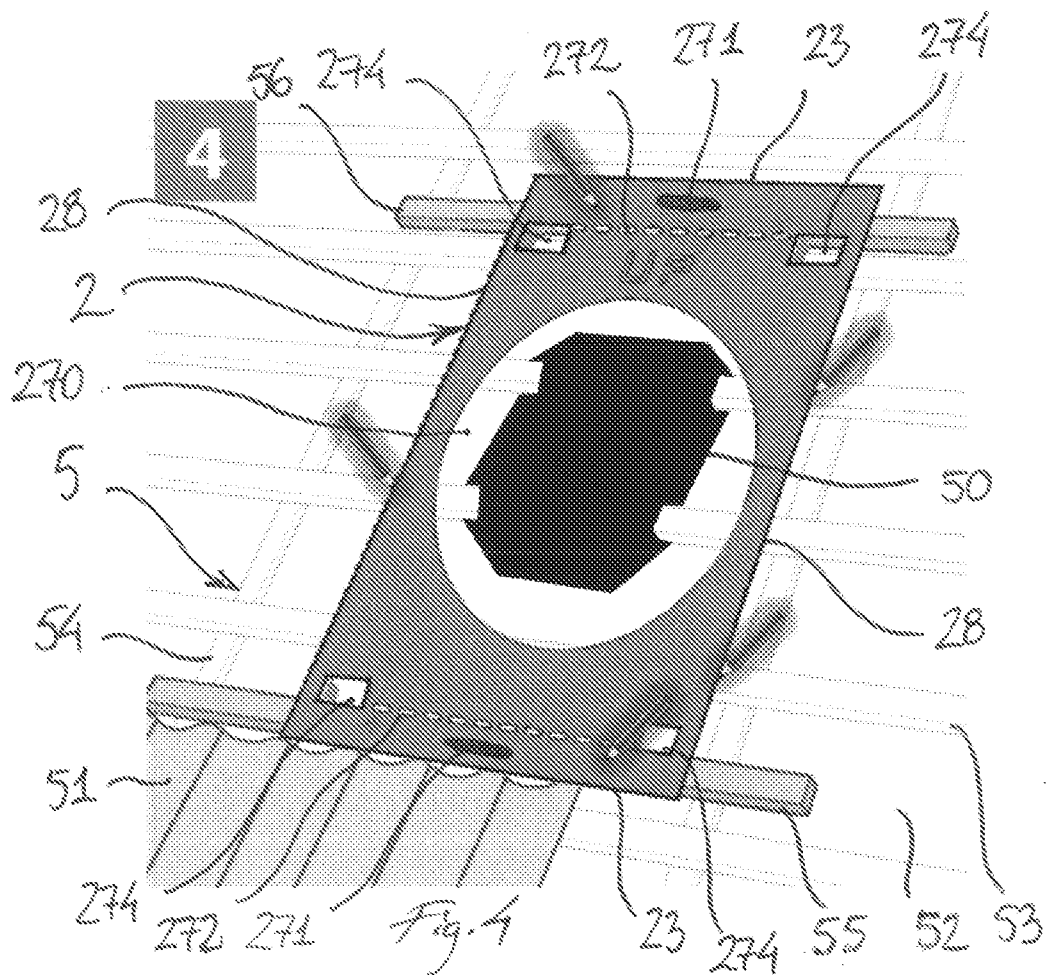
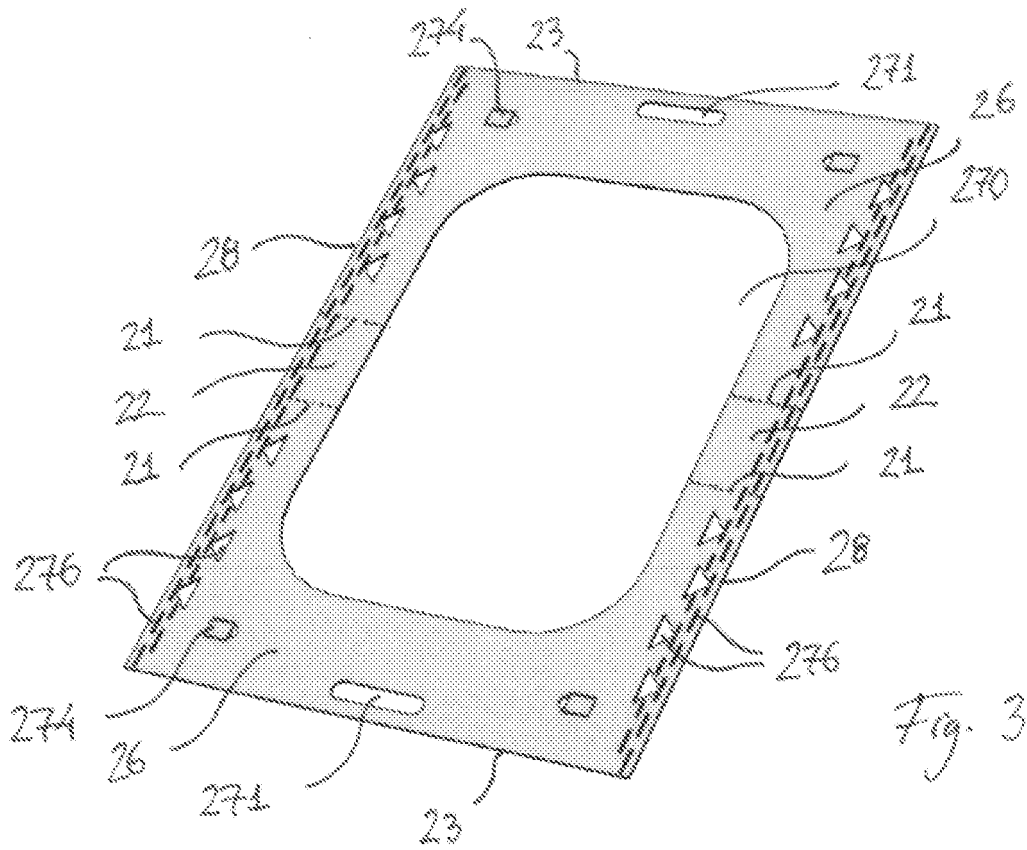



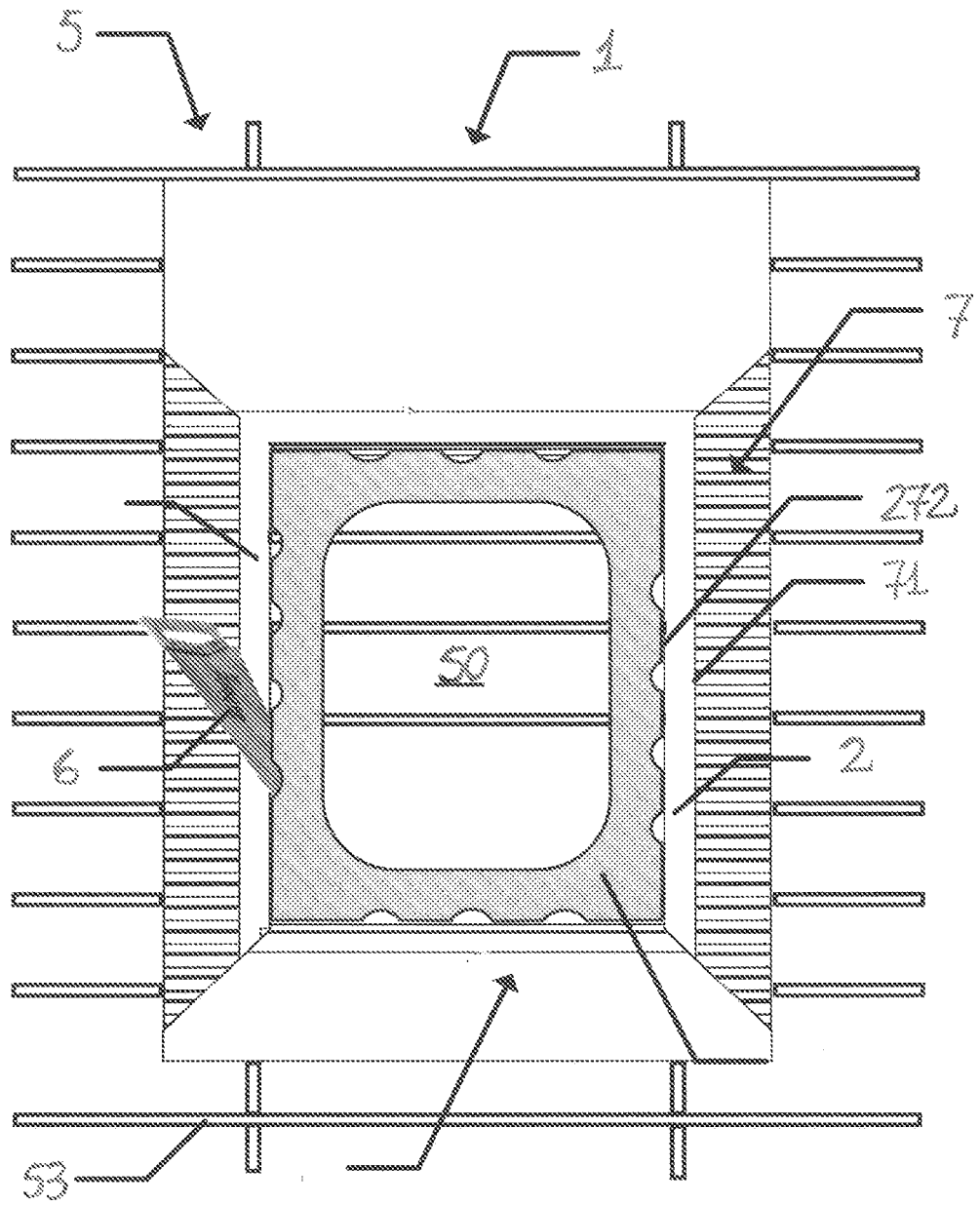
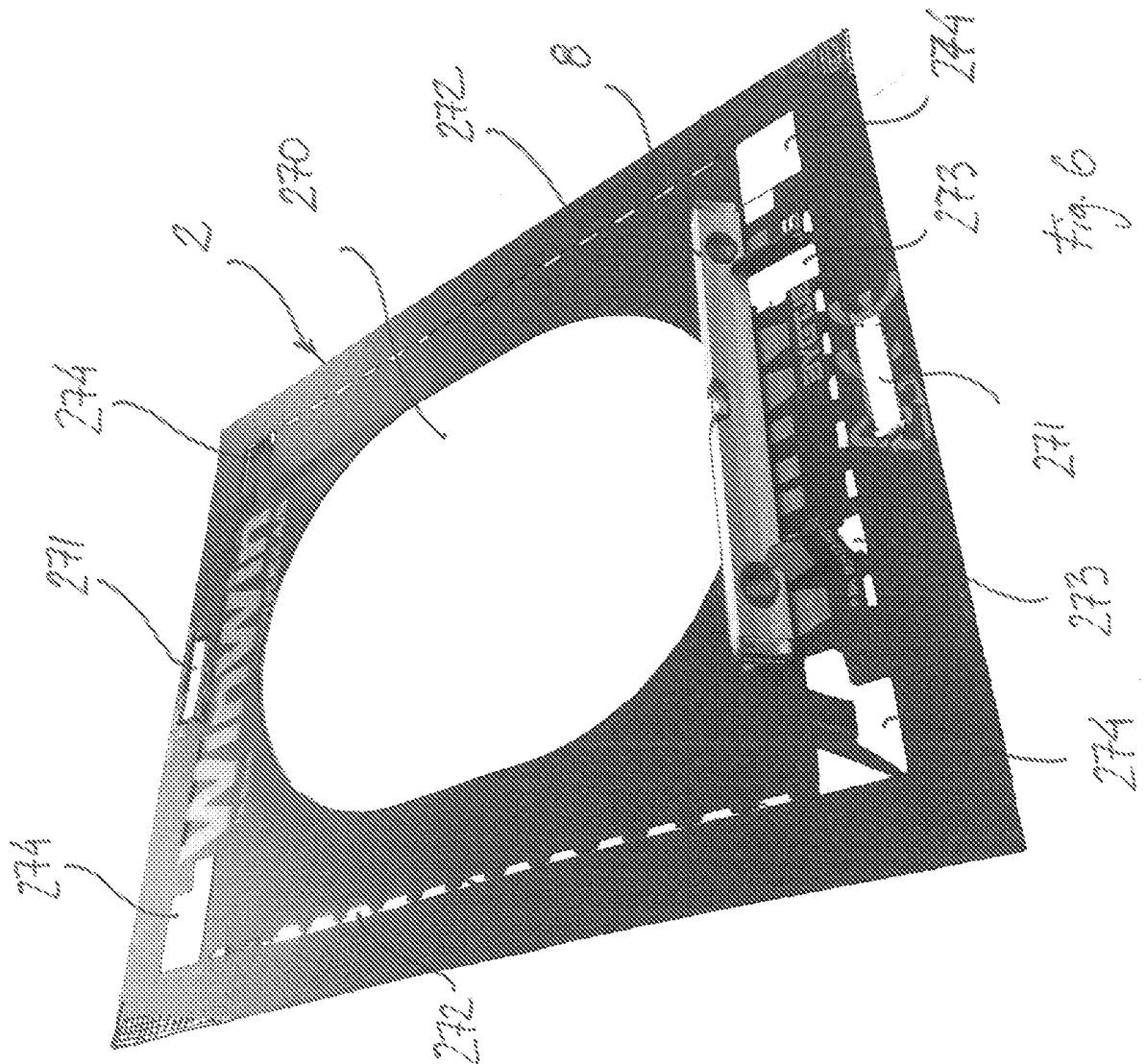
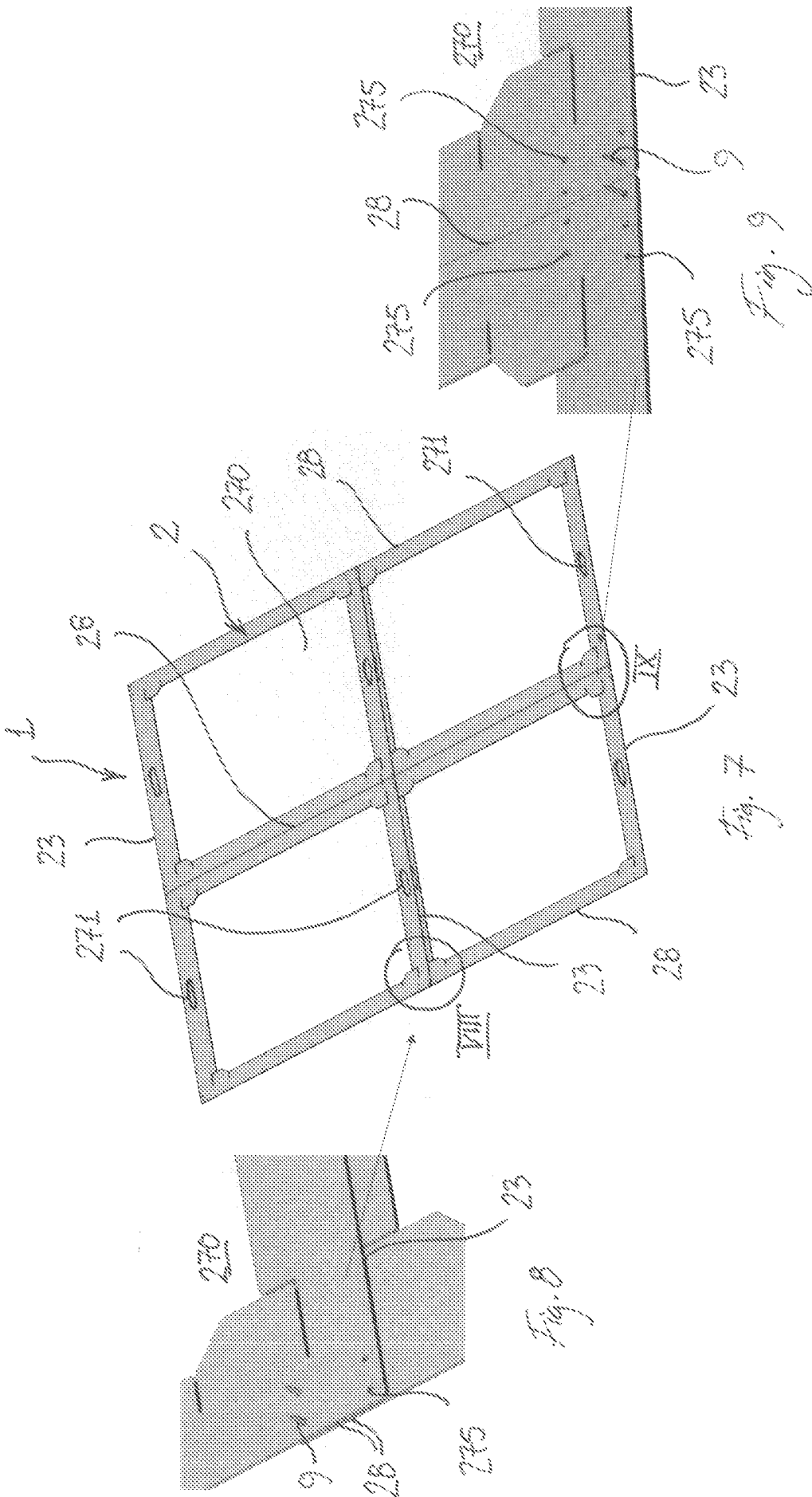

Fig. 5





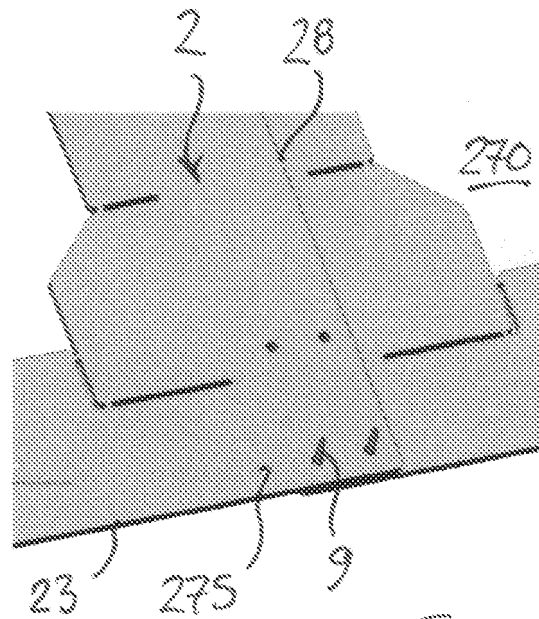

Fig. 10

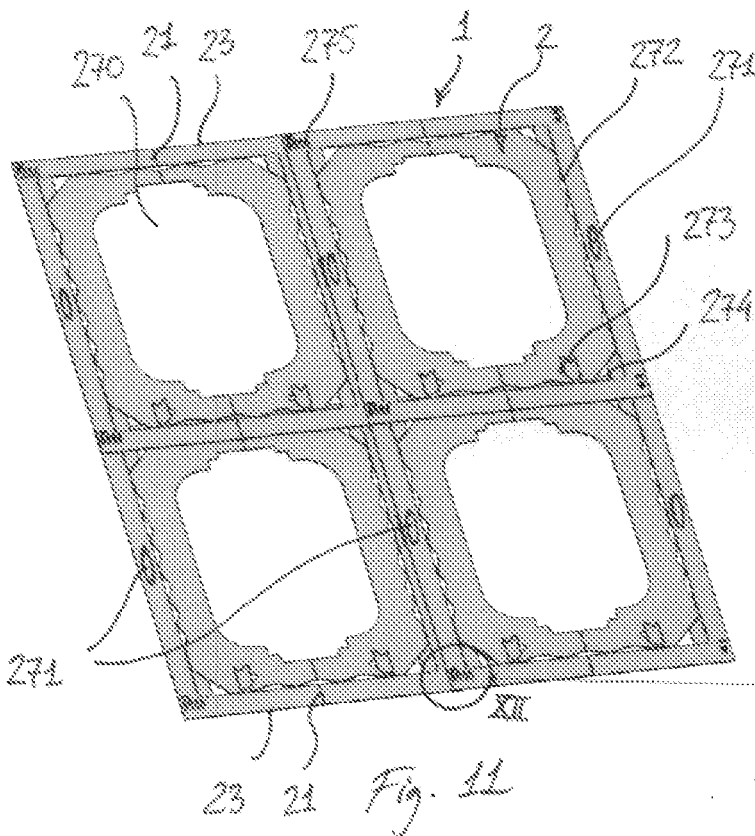

Fig. 11

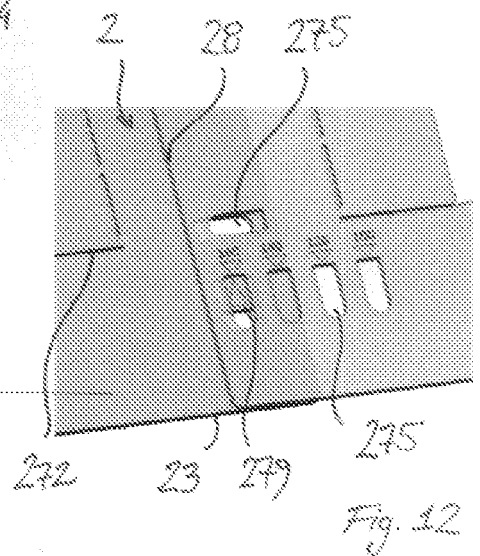

Fig. 12

<b>SEARCH REPORT - PATENT</b>		Application No. PA 2018 70317
1. <input type="checkbox"/> Certain claims were found unsearchable (See Box No. I).		
2. <input type="checkbox"/> Unity of invention is lacking prior to search (See Box No. II).		
<b>A. CLASSIFICATION OF SUBJECT MATTER</b> E 04 D 13/03 (2006.01), B 25 H 7/00 (2006.01) According to International Patent Classification (IPC) or to both national classification and IPC		
<b>B. FIELDS SEARCHED</b>		
PCT-minimum documentation searched (classification system followed by classification symbols) IPC: E04D CPC: B25H, E04D, E04G, E04F, E06B		
Documentation searched other than minimum documentation to the extent that such documents are included in the fields searched DK, NO, SE, FI: IPC-classes as above in Box A		
Electronic database consulted during the search (name of database and, where practicable, search terms used) EPODOC, WPI, FULL TEXT: ENGLISH		
<b>C. DOCUMENTS CONSIDERED TO BE RELEVANT</b>		
Category*	Citation of document, with indication, where appropriate, of the relevant passages	Relevant for claim No.
X	<u>EP 3043007 A1</u> (KNAUF INSULATION) 2016.07.13 See especially paras. [0001-0005], [0007], [0009], [0011-0013], [0022], [0024] and [0037-0038]; claims 1, 15; Fig. 1-5, 10-13	1-15
A	<u>US 5613333 A</u> (WITZIG JR MICHAEL J) 1997.03.25 See column 2, lines 18-26 and claim 5	1-15
A	<u>US 2003217525 A1</u> (KEITH GARY) 2003.11.27 See especially paras. [0008-0009], [0032], claims	1-15
A	<u>US 5195249 A</u> (JACKSON TOMMY) 1993.03.23 See entire document	1-15
<input checked="" type="checkbox"/> Further documents are listed in the continuation of Box C.		
* Special categories of cited documents: "A" Document defining the general state of the art which is not considered to be of particular relevance. "D" Document cited in the application. "E" Earlier application or patent but published on or after the filing date. "L" Document which may throw doubt on priority claim(s) or which is cited to establish the publication date of another citation or other special reason (as specified). "O" Document referring to an oral disclosure, use, exhibition or other means.	"P" Document published prior to the filing date but later than the priority date claimed. "T" Document not in conflict with the application but cited to understand the principle or theory underlying the invention. "X" Document of particular relevance; the claimed invention cannot be considered novel or cannot be considered to involve an inventive step when the document is taken alone. "Y" Document of particular relevance; the claimed invention cannot be considered to involve an inventive step when the document is combined with one or more other such documents, such combination being obvious to a person skilled in the art. "&" Document member of the same patent family.	
Danish Patent and Trademark Office Helgeshøj Allé 81 DK-2630 Taastrup Denmark  Telephone No. +45 4350 8000 Facsimile No. +45 4350 8001		Date of completion of the search report 2018.11.19
		Authorized officer René Sørensen Telephone No. +45 4350 8155

<b>SEARCH REPORT - PATENT</b>		Application No. PA 2018 70317
C (Continuation). DOCUMENTS CONSIDERED TO BE RELEVANT		
Category*	Citation of document, with indication, where appropriate, of the relevant passages	Relevant for claim No.
A	<u>FR 2048327 A5</u> (CONCORDE) 1971.03.19 See entire document	1-15
A	<u>US 2014138429 A1</u> (BEGIM MOSHE) 2014.05.22 See entire document	1-15

--	--	--

**Box No. I Observations where certain claims were found unsearchable**

This search report has not been established in respect of certain claims for the following reasons:

1.  Claims Nos.:

because they relate to subject matter not required to be searched, namely:

2.  Claims Nos.:

because they relate to parts of the patent application that do not comply with the prescribed requirements to such an extent that no meaningful search can be carried out, specifically:

3.  Claims Nos.:

because of other matters.

**Box No. II Observations where unity of invention is lacking prior to the search**

The Danish Patent and Trademark Office found multiple inventions in this patent application, as follows:



**SUPPLEMENTAL BOX**

Continuation of Box [.]