

[72] Inventor **Amir H. Ansari**  
 2484 Stratford Road, Cleveland Heights,  
 Ohio 44118  
 [21] Appl. No. **762,814**  
 [22] Filed **Sept. 26, 1968**  
 [45] Patented **Dec. 8, 1970**

3,330,278 7/1967 Santomieri ..... 128/214.4  
 3,359,978 12/1967 Smith ..... 128/214.4  
 3,399,674 9/1968 Pannier et al. .... 128/214.4  
 3,459,188 8/1969 Roberts ..... 128/347

Primary Examiner—Dalton L. Truluck  
 Attorney—McCoy, Greene & Howell

[54] **SUPRAPUBIC CYSTOSTOMY NEEDLE**  
 7 Claims, 12 Drawing Figs.

[52] U.S. Cl. .... **128/347,**  
 128/214.4, 128/221  
 [51] Int. Cl. .... **A61b 17/34**  
 [50] Field of Search. .... 128/214.4,  
 215, 221, 347, (I.C. Digest); 27/24.1

[56] **References Cited**

**UNITED STATES PATENTS**

2,389,355 11/1945 Goland et al. .... 128/214.4  
 2,566,499 9/1951 Richter ..... 128/221  
 2,952,256 9/1960 Meader et al. .... 128/221

**ABSTRACT:** A hollow needle for performing a suprapubic bladder tap through which a flexible catheter may be fed into the bladder for retention, the needle suited for withdrawal from the suprapubic wound while the catheter remains in the bladder whereupon the needle may be opened along its entire length and removed laterally from the free end of the catheter rather than passing over the catheter's distal end, such needle characterized by a hollow inner member, a hollow outer member telescopically receiving the inner member, and a stylet telescopically received in the inner member, both the inner and outer members being open at both ends and with a longitudinal aperture communicating between said open ends to expose the hollow interiors of the members.

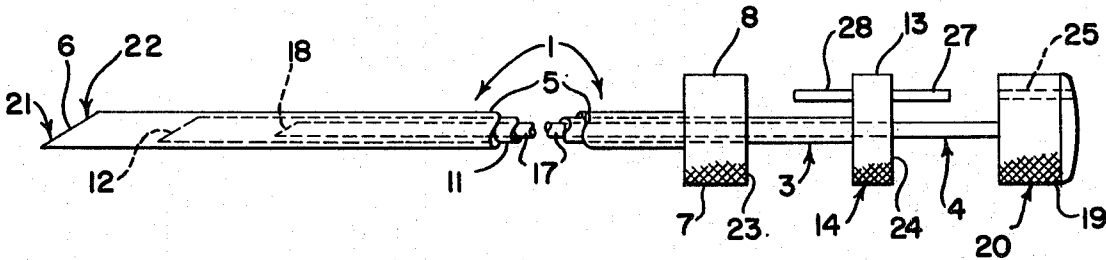

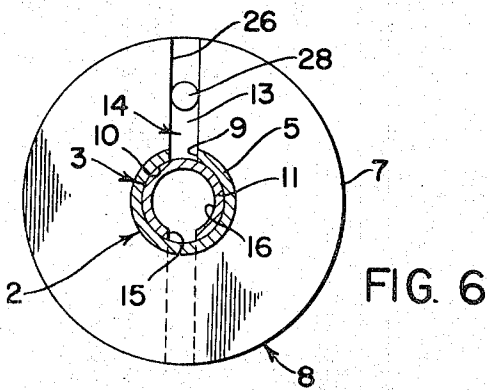
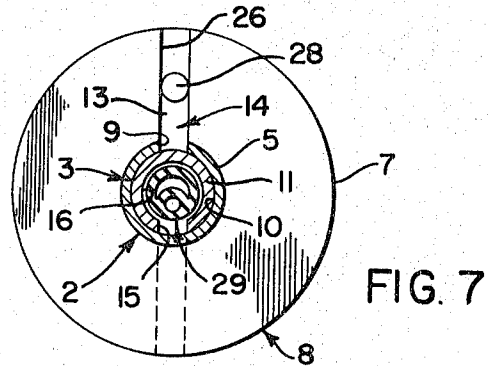
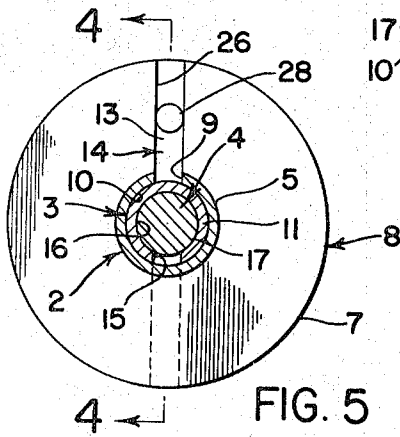
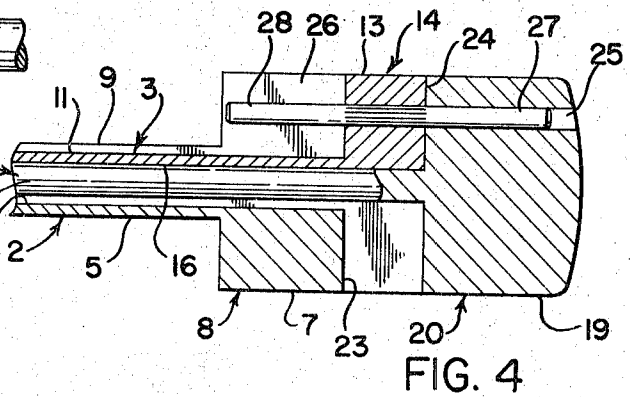
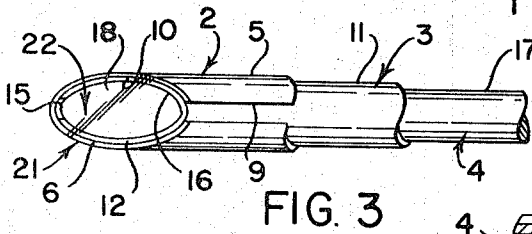
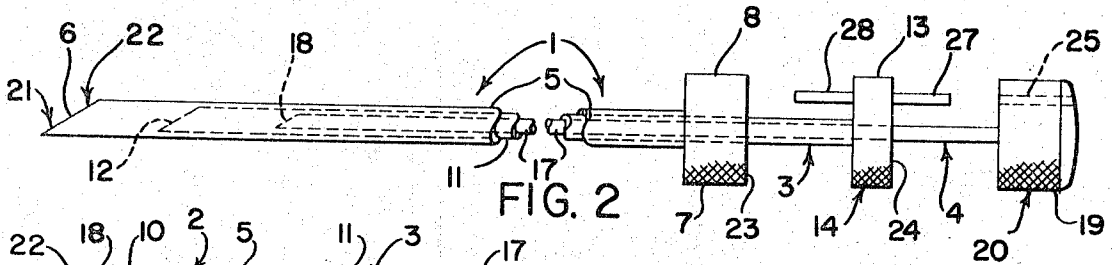
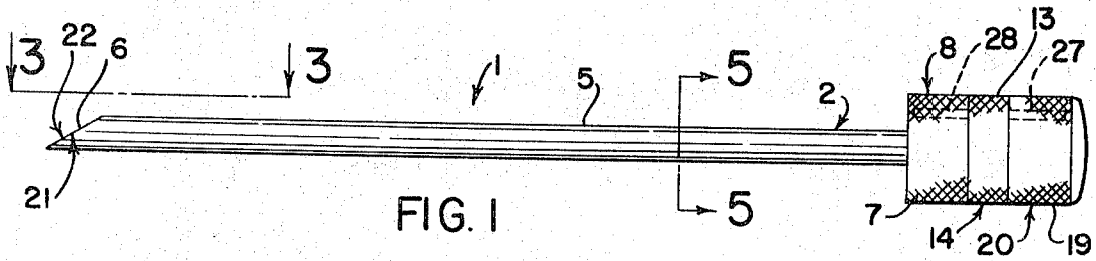

INVENTOR  
AMIR H. ANSARI

BY  
*McCoy, Greene & Howell*

ATTORNEYS

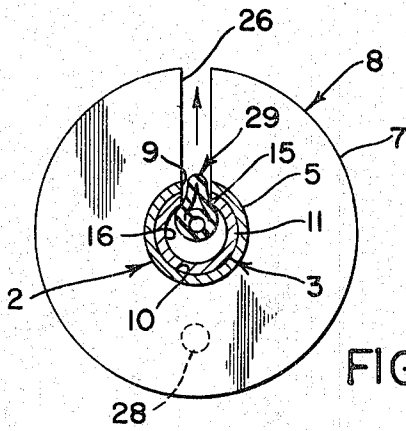

FIG. 8

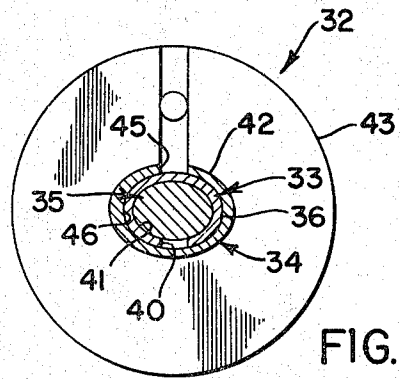

FIG. 9

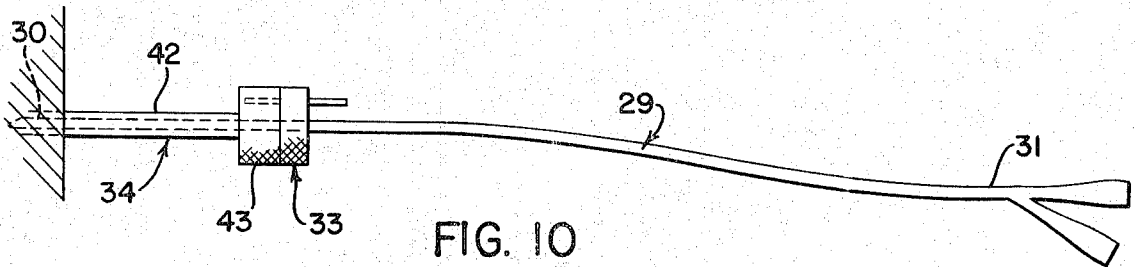

FIG. 10

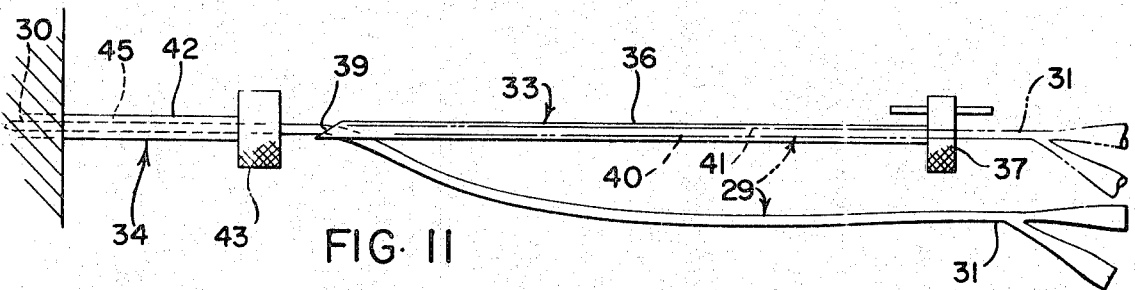

FIG. 11

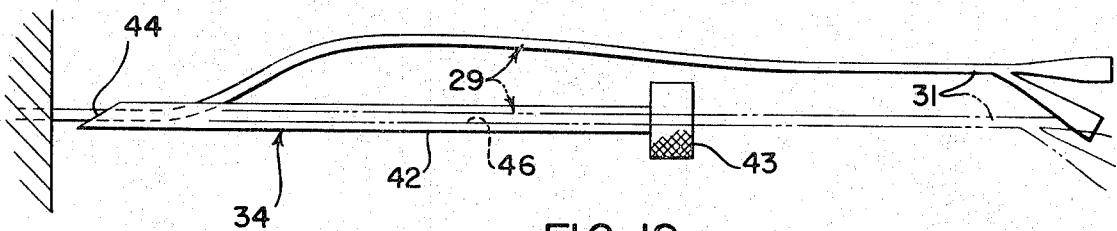

FIG. 12

INVENTOR.  
AMIR H. ANSARI

BY  
*McCoy, Greene & Howell*  
ATTORNEYS

## SUPRAPUBIC CYSTOSTOMY NEEDLE

## THE INVENTION

This invention relates generally to a needle for suprapubic insertion into the bladder of a catheter having an enlarged distal end, and more particularly to a needle for suprapubic bladder insertion of a catheter having a bifurcated distal end, such as a Foley-type catheter, into the bladder, the needle being suited for lateral removal from the catheter.

In the past, where a complete urethral obstruction (e.g., as in cancer of the bladder and prostatic hypertrophy) prevented the subject from voiding his bladder content in a natural fashion, a surgical cystostomy has been performed in which the bladder is opened surgically through the suprapubic area and a catheter having a mushroomlike end is anchored into the bladder. Urethral obstruction is a common problem, especially among males of advanced age, and occasionally requires surgical cystostomy. Surgical cystostomy, however, is very hard on the subject and, in many cases, would never be performed on a particular subject but for the fact that death would certainly occur due to the subject's inability to void body wastes.

Catheterization of the bladder is also mandatory during and for several days after various types of urological, gynecological, and lower abdominal surgery. Urethral catheterization has been the most common procedure in such cases, but has always been accompanied by a high incidence of urinary tract infection (ascending type) as well as a temporary but occasionally prolonged inability of the subject to void spontaneously after the catheter is removed. Suprapubic catheterization has been found to considerably reduce the incidence of urinary tract infection. It has the added advantage that the catheter does not interfere with the urethra and may be left in place until the patient has begun to void spontaneously thereby assuring that the catheter will not be removed prematurely.

Heretofore, suprapubic bladder catheterization, while not unknown, has not been employed routinely to relieve permanent urethral obstruction, nor has it been considered entirely satisfactory for temporary catheterization of the bladder, since there has been no satisfactory way to insert and anchor the proximal catheter tip in the bladder.

The present invention provides a needle with which the proximal end of an inflatable anchor tip catheter (such as the Foley-type catheter) may be inserted through the suprapubic area and anchored in the bladder. The distal ends of such catheters are bifurcated or trifurcated and are consequently too large to pass through the needle so that the needle may be removed from the catheter tube once the catheter is in position. The needle of the present invention may be removed laterally from the catheter tube so that any catheter having a distal end which is too large to pass through the needle may now be inserted into the bladder via the needle and the needle removed. Thus, the needle of the present invention may be employed to implant an anchor-tip catheter in the bladder without major surgery.

Use of the Foley-type catheter has been limited, heretofore, to urethral catheterization. Had a Foley-type catheter been inserted into a subject via any ordinary hollow needle, the needle could not have been subsequently removed from the enlarged distal end of the catheter. It would have been unsatisfactory to leave the sharp needle on the catheter or to employ a hollow needle with a large enough diameter to pass over the distal end of the Foley.

As a consequence, suprapubic bladder catheterization without major surgery has had only limited success because there has been no satisfactory way to anchor the proximal catheter tip in the bladder. The catheter employed has typically been simply a length of polyethylene tubing. While the distal end of such a catheter is small enough to pass through the needle, the only way to anchor the proximal end of the catheter has been to tape the tube to the subject's abdomen. This leaves the proximal tip of the catheter free to move in the

bladder and it is difficult to maintain in proper position in the bladder. The proximal tip of the tube either tends to come out of the bladder or becomes lodged in the urethra. In addition, the tubing must usually be operated like a siphon since the bladder drain opening of the tubing will seldom be submerged unless the bladder is relatively full. A full bladder is to be avoided since the contents tend to leak around the tubing into the space of Retzius and cause serious infection or peritonitis. A further problem is caused by the tendency of the catheter tube to bind or close since it must bend at almost a right angle where it emerges and is taped to the subject's abdomen.

The needle of the present invention permits suprapubic insertion of an anchor tip catheter into the bladder and overcomes the difficulties encountered in the past where a mere length of plastic tubing was employed.

While intravenous tap needles have been constructed which are suitable for lateral removal from intravenous feeding tubes and the like, such needles are unsatisfactory for performing a suprapubic bladder tap. Reference may be had to needles disclosed in the U.S. Pat. No. 3,330,278 to Santomieri and in the U.S. Pat. No. 3,359,978 of Smith which are laterally removable intravenous needles but would be unsuitable for use in a suprapubic bladder tap for a number of reasons, including the relatively great thickness of tissue through which the bladder needle must pass, the nature of the bladder, and the relatively greater danger involved if the tap is not performed properly.

Thus, it is an object of the present invention to provide a needle for suprapubic bladder insertion of an inflatable tip catheter.

It is a further object of the present invention to provide a needle for suprapubic bladder insertion of a catheter with an enlarged distal end.

A still further object of the present invention is to provide a needle with which performance of a permanent or semipermanent suprapubic cystostomy is possible without the necessity for major surgery.

Yet another object of the present invention is to provide a suprapubic cystostomy needle which may be removed laterally from a catheter tube.

Still another object of the present invention is to provide an improved laterally removable needle suitable for use in suprapubic tap placement of a catheter in the bladder.

The invention then comprises the features hereinafter fully described and particularly pointed out in the claims, the following description and the annexed drawing setting forth in detail certain illustrative embodiments of the invention, thus being indicative, however, of but a few of the various ways in which the principle of the invention may be employed.

In said annexed drawing:

FIG. 1 is an elevational view of one embodiment of the needle of the present invention.

FIG. 2 is an elevational view of the needle shown in FIG. 1 with the various elements telescoped slightly apart from one another and with parts broken away.

FIG. 3 is a plan view with parts broken away, taken along the line 3-3 of FIG. 1 of the pointed proximal end portion of the fully assembled needle.

FIG. 4 is a sectional view, taken along the lines 4-4 of FIG. 5 and with parts broken away, of the distal end of the fully assembled needle shown in FIG. 1.

FIG. 5 is a sectional view, taken along the lines 5-5 of FIG. 1, of the fully assembled needle.

FIG. 6 is a sectional view similar to that shown in FIG. 5, but with the stylet element removed.

FIG. 7 is a sectional view similar to FIG. 6 but showing a catheter tube in position in the needle.

FIG. 8 is a sectional view similar to FIG. 7 but showing the inner member rotated 180° and the catheter tube being removed laterally from the needle.

FIG. 9 is a cross-sectional view of an alternate embodiment of the needle of the present invention.

FIG. 10 illustrates the needle shown in FIG. 9 when it is inserted in the subject with the catheter in the needle.

FIG. 11 shows how the inner member of the needle shown in FIG. 10 may be removed laterally from the catheter.

FIG. 12 shows how the outer member of the needle shown in FIG. 10 may be removed laterally from the catheter after the inner member has been removed as shown in FIG. 11.

Referring more particularly to the drawings and to the embodiment illustrated in FIGS. 1—8, it will be seen that the suprapubic cystostomy needle 1 of the present invention comprises a hollow elongated outer member 2, a hollow elongated inner member 3 telescopically received in the outer member 2, and an elongated stylet 4 telescopically received in the hollow inner member 3. The outer member 2 has an elongated shank portion 5, circular in cross section, with a pointed proximal end 6 and a radially extending knurled disc portion 7 serving as a grip at its distal end 8. The proximal and distal ends 6 and 8 are open and a longitudinal aperture 9, formed in the shank 5, point 6, and grip portions 7, communicates between the open distal and proximal ends to expose the outer member's hollow interior 10.

The inner member 3 is similar to said outer member 2, having an elongated shank portion 11, circular in cross section, with a pointed proximal end 12 and a radially extending knurled disc portion 13 serving as a grip at its distal end 14. The proximal and distal ends 12 and 14 are open and a longitudinal aperture 15 formed in the shank 11, point 12, and grip portions 13, communicates between the open distal and proximal ends 14 and 12 to expose the inner member's hollow interior 16.

The shank 11 of the inner member 3 is of slightly smaller cross-sectional diameter than the shank 5 of the outer member 2 so that it will fit telescopically inside the hollow outer member 2. The bevel of the inner member's pointed end 12 matches the bevel of the outer member's pointed end 6 so that they form a regular side bevel needle point when aligned. In the outer member 2, the longitudinal aperture 9 communicates with the open proximal end 6 and the base of the beveled point, whereas in the inner member 3, the longitudinal aperture 15 communicates with the open proximal end 12 at the tip of the beveled point, as is best illustrated in FIG. 3.

Thus, when the pointed proximal ends 6 and 12 of the inner and outer members 3 and 2 are aligned, the shank 5 of the outer member 2 overlays the longitudinal aperture 15 of the inner member 3 and they form an open ended cylinder in this arrangement. When so arranged, and when the stylet 4 is in place, the needle 1 is ready for injection.

Since the shank 3 of the inner needle 3 is circular in cross section, it may be rotated within the outer member 2 and when, as shown in FIG. 8, the longitudinal aperture 15 of the inner member 3 is rotated into alignment with the longitudinal aperture 9 of the outer member 2, the interior 16 of the inner member 3 is exposed laterally along its entire length. A catheter tube may be removed laterally from the needle 1 when the inner and outer members 3 and 2 are arranged in this fashion.

The stylet 4 has an elongated shank 17 portion, circular in cross section, with a proximal pointed end 18 and a radially extending knurled disc portion 19 serving as a grip at its distal end 20. Unlike the inner member 3 and outer member 2, the stylet 4 is solid. It has a cross-sectional diameter slightly smaller than that of the inner member 3 and is telescopically received therein. The stylet 4 may be withdrawn axially from the inner member 3.

The proximal end 18 of the stylet 4 has a regular side bevel needle point of similar bevel to the points 12 and 6 of the inner member and outer member. Thus, when the needle 1 is assembled with the proximal points 12, 6 and 18 of the inner member 3, outer member 2, and stylet 4 in alignment, those points 6, 12 and 18 form a regular side bevel needle point 21 with a substantially smooth faced common surface 22, as best illustrated in FIG. 3 of the drawings. When so assembled, the disc portions 7, 13 and 19 of the outer member 2, inner member 3 and stylet 4 are in side-by-side coaxial alignment

with the disc portion 13 of the inner member 3 resting against the distal surface 23 of the outer member's disc portion 7, and with the disc portion 19 of the stylet resting against the distal surface 24 of the inner member's disc portion 13. Thus, it is important that the disc portions 7, 13 and 19 of the inner member 3, outer member 2 and stylet 4 be located at a measured distance from the points 6, 12 and 18 of those members 3, 2 and 4 since they serve to stop those members 3, 2 and 4 in longitudinal alignment to form the cystostomy needle point 21.

The grip portion of the stylet 4 is preferably provided with a small longitudinally extending aperture 25. When the inner needle 3 is rotated into the closed position within the outer needle 2, this aperture 25 is aligned with the portion 26 of the longitudinal aperture 9 formed in the grip 7 of the outer member 2. Small rigid fingers 27 and 28 extend longitudinally from either side of the inner member's disc grip 13 and are received in the aforementioned aligned aperture 25 and aperture portion 26 in the disc grips of the stylet 4 and outer member 2 to lock the stylet 4, inner member 3 and outer member 2 against rotation with respect to one another. The locking feature keeps the members 2, 3 and 4 aligned during insertion of the needle 1, and also serves to keep the inner member 3 and outer member 2 aligned while the catheter tube is being fed into the bladder after the stylet 4 has been removed.

The operation of the needle 1 of the present invention during the performance of a suprapubic bladder catheterization is best illustrated in FIGS. 4—8. Prior to insertion, the needle 1 is assembled as shown in FIGS. 1, 3, 4 and 5 with the stylet 4 received in the inner member 3 which is, in turn, received in the outer member 2, and with the proximal ends of the three members in rotational alignment, as shown in FIG. 3, so that the outer member 2 overlays the longitudinal aperture 15 of the inner member 3, as shown in FIGS. 3 and 5. In performance of the cystostomy, the proximal tip 21 of the assembled needle 1 is inserted directly into the bladder via the suprapubic area. The stylet 4 is then withdrawn so that the needle interior is now open as shown in FIG. 6. Next, a catheter 29 is fed through the needle 1, as shown by reference to FIG. 7, until its tip 30 enters the bladder. If the catheter is the Foley-type, its proximal end 30 is then inflated, whereupon the needle 1 is withdrawn from the bladder, and the proximal tip 30 of the catheter 29 remains anchored in place in the bladder. Once the needle 1 is free of the subject, its inner and outer members 3 and 2 are pulled apart slightly and then rotated relative to one another to align their longitudinal apertures 9 and 15 in communicating relationship, whereupon the catheter 29 may be removed laterally as shown in FIG. 8.

Several features of the needle 1 are worthy of special attention in reference to the above-described operation. For one, when the needle 1 is in place in the subject with the stylet 4 removed as in FIG. 6, body tissue would tend to protrude into the hollow interior 16 of the inner member 3 but for the fact that the outer member 2 overlays the longitudinal aperture 15 of the inner member 3. This would obstruct the inner needle passage 16 and prevent or hinder passage of the catheter 29 therethrough.

In addition, during insertion of the needle, it is important that the proximal end 18 of the stylet 4 substantially fills and obstructs the open proximal end 12 of the inner member 3 so that tissue will not intrude therein to any substantial degree. Otherwise, insertion of the needle 1 would be impractical. The needle 1 would tend to cut out a plug of tissue during insertion. This is an especially significant problem where the needle 1 must pass through relatively thick layers of fatty and muscular tissue, as is common at the site of the suprapubic insertion. Not only would a plug of tissue obstruct passage of the catheter 29 through the needle 1 on its way to the bladder, but the procedure may be complicated by excessive bleeding, infection and healing problems. A circular hole in the bladder would also leak for a long period of time before healing shut. The needle 1 of the present invention cuts a slit when it is in-

sented. When the needle 1 and/or catheter 29 are removed, the wound closes together immediately to minimize bladder leakage and facilitate healing.

Further, it is apparent that where the longitudinal finger 28 extends from the disc grip 13 of the inner member 3 into the aperture portion 26 of the outer member 2, the inner member 3 and outer member 2 may not be rotated directly from the closed position as shown in FIG. 7 to the open position shown in FIG. 8 without first withdrawing the inner member 3 from the outer member 2 a short distance to disengage the finger 28. It may be desirable to place a second longitudinal aperture (not shown) in the disc 7 of the outer member 2 at a position to receive the finger 28 when the inner and outer members 3 and 2 are aligned in the open position as shown in FIG. 8. While location of the fingers 27 and 28 on the disc 13 of the inner member 3 is preferred, they could be placed in other locations and other locking means could be used as will be readily apparent to persons of ordinary skill.

While the above-described procedure for removing the needle 1 from the catheter tube 29 (characterized by rotating the inner and outer members 3 and 2 from closed to open position as shown in FIGS. 7 and 8) is preferable for the embodiment of the present invention described above and illustrated in FIGS. 1-8, this is not the only way that the needle 1 of the present invention may be removed from the catheter 29. Alternatively, the inner member 3 may be withdrawn from the outer member 2 and these members removed separately from the catheter tube 29. If the free end 31 of the catheter 29 is long enough, the inner member 3 may be separated from the outer member 2 on the catheter 29 after the inner member 3 and outer member 2 have been withdrawn together from the subject. However, if the free end 31 of the catheter 29 is too short to accommodate the two members 3 and 2 end to end, the inner member 3 may be withdrawn from the outer members 2, as shown in FIG. 10, and removed from the catheter 29 before the latter member is withdrawn from the subject, as shown in FIG. 11. The outer member 2 may then be withdrawn from the subject and removed laterally from the catheter 29 as shown in FIG. 12. Alternatively, the inner and outer members 3 and 2 may be withdrawn from the subject together and the catheter 29 stripped laterally from the inner member 3 as it is being withdrawn from the outer member 3.

Bearing in mind the above-described three alternative methods of removing the needle 1 from the catheter 29 without rotating the inner member 3 inside the outer member 2, a second embodiment of the present invention is shown in FIGS. 9-12 wherein a needle 32 has an inner member 33 which is noncircular and therefore may not be rotated inside the outer member 34. A needle 32 formed in this manner self-locks against rotation of the members 33 and 34 within one another. It need not have finger or means other than its non-circular cross section to lock it against rotation. It must therefore be removed laterally from the catheter 29 according to any of the above-described three alternative methods, one of which, the second described, is illustrated step by step in FIGS. 10-12.

Briefly, the alternative embodiment of the needle 32 of the present invention which is illustrated in FIG. 9 has an elongated stylet 35 which is elliptical in cross section with a grip at its distal end and a side-beveled point at its proximal end and is removably and telescopically received in a hollow elongated inner member 33. The inner member 33 has an elliptical cross section shank 36 with a grip 37 at its distal end and a point 39 at its proximal end, both the distal and proximal ends being open with a longitudinal aperture 40 communicating therebetween to expose the hollow inner needle interior 41. The inner member 33 is removably and telescopically received in an elongated hollow outer member 34 having an elliptical cross section shank 42 with a grip 43 at its distal end and a point 44 at its proximal end, both the distal end and proximal end being open with a longitudinal aperture 45 communicating therebetween. The longitudinal aperture 40 of the inner member 33 communicates with the open proximal end

at the tip of the needle point 39, whereas the longitudinal aperture 45 of the outer member 34 communicates with the open proximal end at the base of the needle point 44 so that when the inner member 33 and outer member 34 are assembled with their proximal ends 39 and 44 aligned to form a common side bevel needle point, the outer member 34 overlays the longitudinal aperture 40 of the inner member 33 to prevent tissue from protruding laterally through the longitudinal aperture 40 into the hollow inner member interior 41 when the needle 32 is in the subject.

Construction and operation of this alternate embodiment of the present invention is essentially similar in all other material respects to the first described embodiment and it will be apparent that a needle according to the present invention may have a cross section of still other noncircular cross sections, as will be apparent to persons of ordinary skill. It is important, however, to keep the outer diameter of the outer needle shank small so as to minimize the size of the wound in the bladder and, for this reason, a shank with a certain cross section may be preferable to another depending, among other things, upon the shape of the catheter and the shape of the needle point.

Although the foregoing has been described with respect to the removal of fluids from the bladder, it is obvious that the reverse is also possible. That is, the catheter may be used to irrigate the bladder if desired.

Furthermore, while the foregoing has been described primarily with reference to its use with a Foley-type catheter, it is not intended to be limited to use with such catheter, but is designed for use with any catheter having an enlarged distal end.

It is also obvious that modifications and alterations to the structure, including variations in size and gauge, will occur to those having skill in the art after having had reference to the foregoing drawing and description. However, it is not intended to limit the scope of the invention by the preceding description and drawings, but by the scope of the appended claims.

I claim:

1. A needle for suprapubic tap placement of a catheter in the bladder, said needle having a pointed proximal end and a distal end and comprising:
  - a hollow elongated outer member having an open distal end, an open proximal end, and a longitudinal aperture communicating therebetween to expose the hollow interior of said outer member;
  - a hollow elongated inner member telescopically received in said outer member, said inner member having an open distal end, an open proximal end, and a longitudinal aperture communicating therebetween to expose the hollow interior of said inner member, said inner and outer members coaxially movable relative to one another between open and closed positions, said closed position characterized by said outer member overlaying said longitudinal aperture of said inner member so that when said needle is inserted into said bladder tissue will not protrude laterally through said longitudinal aperture of said inner member to obstruct passage of a catheter into the bladder therethrough, and said open position characterized by location of said outer member not to obstruct lateral removal of a catheter through said longitudinal apertures of said inner and outer members; and
  - an elongated stylet telescopically received in said inner member to obstruct its open proximal end so that tissue will not intrude therein to any substantial degree during insertion of said needle into the bladder, said stylet suited for axial withdrawal from the distal end of said inner member.
2. A needle as recited in claim 1 wherein said outer and inner members are each circular in cross section, and wherein said inner and outer members are coaxially rotatable relative to one another between said closed and open positions, said open position characterized by telescopic disposition of said inner member within said outer member with the proximal ends, distal ends, and longitudinal apertures of said outer and inner members aligned respectively.

7

8

3. A needle as recited in claim 2 including means for locking said inner and outer member against rotation out of said closed position.

4. A needle as recited in claim 3 wherein a radial projection extends from the distal end of each of the said inner member and stylet so that the radial projection of said inner member stops said inner member at a predetermined location when inserted longitudinally into said outer member, and so that the radial projection of said stylet stops said stylet at a predetermined location when inserted longitudinally into said inner member, and wherein the proximal ends of said inner member, said outer member and said stylet are shaped to form said proximal point of said needle when said proximal ends of said inner member, outer member, and stylet are aligned radially and longitudinally, said radial projections stopping said inner member, outer member and stylet with their proximal ends in longitudinal alignment.

5. A needle as recited in claim 4 wherein a radial projection extends from the distal end of said outer member, wherein the radial projections of said inner member, said outer member and said stylet are disc shaped with knurled edge surfaces to facilitate manual withdrawal of said stylet from said inner member and to facilitate manual rotation of said inner and outer members between open and closed positions, and

wherein said locking means comprise a finger portion extending longitudinally from one of said radial discs, said finger portion received in apertures provided in the other two radial discs such apertures aligned to receive said finger portion only when said proximal ends of said inner member, outer member and stylet are radially aligned to form said needle point.

6. A needle as recited in claim 1 wherein said inner member and said outer member are noncircular in cross section so that they will not rotate out of said closed position but are suited for telescopic coaxial withdrawal, one from the other, to move from said closed position to said open position.

7. A needle as recited in claim 6 wherein a radial projection extends from the distal end of each of the said inner member and stylet so that the radial projections of said inner member and stylet stop said inner member and stylet at predetermined locations when inserted longitudinally into said outer member and inner member respectively, and wherein the proximal ends of said inner member, said outer member and said stylet are shaped to form said proximal point of said needle when said proximal ends of said inner member, outer member and stylet are aligned radially and longitudinally, said radial projections stopping said inner member, outer member and stylet with their proximal ends in longitudinal alignment.

5  
10  
15  
20  
25  
  
30  
  
35  
  
40  
  
45  
  
50  
  
55  
  
60  
  
65  
  
70  
  
75