

(19) World Intellectual Property Organization
International Bureau



(43) International Publication Date
11 January 2007 (11.01.2007)

PCT

(10) International Publication Number
WO 2007/004017 A1

- (51) International Patent Classification:
G01S 1/00 (2006.01)
- (21) International Application Number:
PCT/IB2006/001793
- (22) International Filing Date: 28 June 2006 (28.06.2006)
- (25) Filing Language: English
- (26) Publication Language: English
- (30) Priority Data:
11/170,876 30 June 2005 (30.06.2005) US
- (71) Applicant (for all designated States except US): **NOKIA CORPORATION** [FI/FI]; Keilalahdentie 4, FIN-02150 ESPOO (FI).
- (71) Applicant (for LC only): **NOKIA, INC.** [US/US]; 6000 Connection Drive, Irving, TX 75039 (US).
- (72) Inventors; and
- (75) Inventors/Applicants (for US only): **EEROLA, Ville** [FI/FI]; Luhtialankatu 11, FIN-Hameenlinna 13220 (FI).

- PIETILA, Samuli** [FI/FI]; Eetunkatu 2 B 7, FIN-33560 Tampere (FI). **VALIO, Harri** [FI/FI]; Vattulantie 17, FIN-34240 Kämmenniemi (FI).
- (74) Agent: **ALBERT, Peter, G., Jr.**; Foley & Lardner LLP, 11250 El Camino Real, Suite 200, San Diego, CA 92130 (US).
- (81) Designated States (unless otherwise indicated, for every kind of national protection available): AE, AG, AL, AM, AT, AU, AZ, BA, BB, BG, BR, BW, BY, BZ, CA, CH, CN, CO, CR, CU, CZ, DE, DK, DM, DZ, EC, EE, EG, ES, FI, GB, GD, GE, GH, GM, HN, HR, HU, ID, IL, IN, IS, JP, KE, KG, KM, KN, KP, KR, KZ, LA, LC, LK, LR, LS, LT, LU, LV, LY, MA, MD, MG, MK, MN, MW, MX, MZ, NA, NG, NI, NO, NZ, OM, PG, PH, PL, PT, RO, RS, RU, SC, SD, SE, SG, SK, SL, SM, SY, TJ, TM, TN, TR, TT, TZ, UA, UG, US, UZ, VC, VN, ZA, ZM, ZW.
- (84) Designated States (unless otherwise indicated, for every kind of regional protection available): ARIPO (BW, GH, GM, KE, LS, MW, MZ, NA, SD, SL, SZ, TZ, UG, ZM, ZW), Eurasian (AM, AZ, BY, KG, KZ, MD, RU, TJ, TM),

[Continued on next page]

(54) Title: SYSTEM AND METHOD FOR PROVIDING OPTIMIZED RECEIVER ARCHITECTURES FOR COMBINED PILOT AND DATA SIGNAL TRACKING

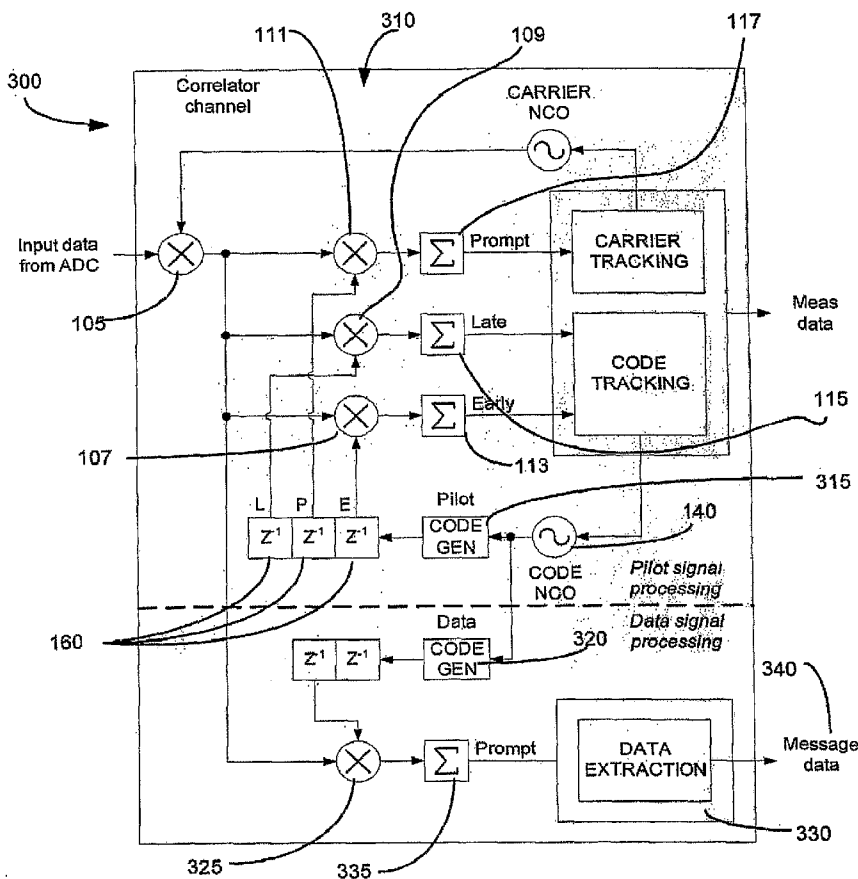

(57) Abstract: A system architecture for a receiver to process multiple signals on a common carrier frequency from a satellite. The receiver is arranged such that the receiver receives input data transmitted from the satellite. A pilot signal is tracked from the input data using a correlation channel, and a data signal is tracked from the input data using a data code generator operatively connected to the correlation channel. In one embodiment of the invention, the data signal generator creates replica code for the data signal. In another embodiment of the invention, the system can switch between the data signal generator and pilot signal generator based upon the signal-to-noise ratio of the incoming signal.

WO 2007/004017 A1



European (AT, BE, BG, CH, CY, CZ, DE, DK, EE, ES, FI, FR, GB, GR, HU, IE, IS, IT, LT, LU, LV, MC, NL, PL, PT, RO, SE, SI, SK, TR), OAPI (BF, BJ, CF, CG, CI, CM, GA, GN, GQ, GW, ML, MR, NE, SN, TD, TG).

— *before the expiration of the time limit for amending the claims and to be republished in the event of receipt of amendments*

Published:

— *with international search report*

For two-letter codes and other abbreviations, refer to the "Guidance Notes on Codes and Abbreviations" appearing at the beginning of each regular issue of the PCT Gazette.

**SYSTEM AND METHOD FOR PROVIDING OPTIMIZED
RECEIVER ARCHITECTURES FOR COMBINED PILOT AND
DATA SIGNAL TRACKING**

FIELD OF THE INVENTION

[0001] The present invention relates generally to receivers for Global Navigation Satellite Systems. More particularly, the present invention relates to hardware configurations for Global Navigation Satellite System receivers.

BACKGROUND OF THE INVENTION

[0002] Satellite navigation is based on a global network of satellites that transmit signals from several thousand miles in earth orbit. A number of different Global Navigation Satellite Systems (GNSS) have either been launched or are in advanced stages of development. For example, a Galileo is an example of a GNSS system which will ultimately provide a highly accurate, guaranteed global positioning service under civilian control. It is anticipated that Galileo will be inter-operable with other global satellite navigation systems such as American-based Global Position System (GPS) and the Russian-based Global Orbiting Navigation Satellite System (GLONASS).

[0003] In a GNSS such as Galileo (when available), a user is able to use his or her receiver to compute the receiver's a position using any of the satellites in any combination. It is anticipated that a system such as Galileo will be capable of delivering real-time positioning accuracy within a matter of meters.

[0004] New and proposed GNSS systems, such as Galileo, as well as a modernized GPS, will use two separate signals. One signal, referred to herein as the pilot signal, is used to provide good acquisition and tracking properties. The other signal, referred to herein as the data signal, is used to carry the satellite data message. GNSS receivers need to possess the ability to receive both signals in order to operate satisfactorily. The pilot signal is used for efficient acquisition and low signal-to-noise ratio (SNR) tracking. The data signal is used to receive the satellite data message that

is required for navigation. It should be noted that, while the receiver needs the information contained in the satellite data message, it does not matter how the information is obtained. For example, an aided GNSS system may obtain the data using other forms of communication. However, if the receiver is intended for standalone use (i.e., without any aiding sources), then it does need to obtain the data message when in standalone operation. Standalone capabilities are often required features of GNSS receivers.

[0005] If the GNSS system at issue has separate pilot and data signals, then the GNSS satellites transmit the pilot and data signals on a common carrier frequency. The pilot signal and the data signal are designed so that the receiver can distinguish between the two signals. The GNSS receiver needs to be able to receive two signals from each satellite that is used for the particular transmission, although the reception does not need to be simultaneous. However, the need to receive two separate signals makes the required hardware for the receiver bigger. The hardware size is also directly tied to the product cost. To solve this problem, more efficient receiver architectures are needed which minimize the hardware complexity.

[0006] Conventional GNSS systems do not utilize separate pilot and data signals. Currently, GPS coarse/acquisition (C/A) code and precise/encrypted (P/Y) code could be considered to be somewhat similar to pilot and data signals, respectively, but such arrangements are not generally available for commercial GPS receivers. In the past, P/Y-code capable GPS receivers have implemented completely separate hardware for reception of the C/A code and the P/Y code. However, this involves essentially duplicating the hardware involved, which increases the product complexity and cost. Although some military-grade receivers can directly acquire the P/Y code without utilizing C/A code, this requires even more expensive receiver hardware.

[0007] Figure 1 shows a typical conventional GNSS receiver correlation channel that is used to track one satellite signal (either a data signal or a pilot signal). There are several variations for achieving a smaller hardware configuration or a higher performance level. Figure 2 shows how two such channels can be used to use both pilot and data signals from one satellite, thus duplicating the hardware size needed for each satellite. In this arrangement, a correlator channel for the pilot signal is used for

measurement data, while a correlator channel for the data signal is used for message data. "Measurement data" refers to the measurement data that the receiver generates regarding the signal timing. This data is used in the position and velocity computation process in the receiver. This data typically includes code phase information, carrier phase information, and code and carrier frequency information.

[0008] In the conventional GPS implementation, the C/A code and the P/Y code are such different and require so different processing rates that using a common processing channel to achieve the reception of both signals is not cost-effective.

SUMMARY OF THE INVENTION

[0009] The present invention provides for a system and method for efficiently reducing the hardware complexity required for enabling the reception of both a pilot signal and a data signal in a GNSS receiver. In one embodiment of the invention, information from the pilot signal is used to track both signals from the satellite such that only the demodulation of the data signal is necessary for efficient operation. A second embodiment of the invention involves the implementation of only one hardware channel to alternately track both the pilot signal and the data signal. In this situation, for satellite acquisition, the pilot signal is used, and for high signal-to-noise ratio tracking, the data signal is used. The pilot signal is used for low signal-to-noise ratio tracking.

[0010] The system and method of the present invention provides a solution for enabling a receiver to receive both pilot and carrier signals from a GNSS satellite with minimal hardware. In the case where information from the pilot signal is used to track both signals from the satellite, there is a minimal performance penalty through the use of some additional hardware. In the case where a single hardware channel alternately tracks both the pilot signal and the data signal, there is no hardware size increase at all over receivers capable of only using the data signal, although some performance is sacrificed compared to receivers that receive both signals simultaneously. However, this performance is still substantially better than with those receivers that only track the data signal. Tracking only either the pilot or data signal

simplifies the software. Using less hardware also decreases the power consumption of the receiver.

[0011] These and other advantages and features of the invention, together with the organization and manner of operation thereof, will become apparent from the following detailed description when taken in conjunction with the accompanying drawings, wherein like elements have like numerals throughout the several drawings described below.

BRIEF DESCRIPTION OF THE DRAWINGS

[0012] Figure 1 is a representation of a conventional GNSS receiver correlation channel that is used to track a single satellite channel;

[0013] Figure 2 is a representation showing how two receiver correlation channels can be used to receive both pilot signals and data signals from a satellite;

[0014] Figure 3 is a representation of an optimized receiver architecture including an optimized pilot and data signal tracking channel according to one embodiment of the invention;

[0015] Figure 4 is a representation of a dynamic pilot and data signal switching system according to another embodiment of the present invention;

[0016] Figure 5 is a representation showing a generic receiver and satellite system within which the present invention may be implemented; and

[0017] Figure 6 is a schematic representation of a positioning receiver constructed according to one embodiment of the present invention.

DETAILED DESCRIPTION OF THE INVENTION

[0018] The present invention provides for a system and method for efficiently reducing the hardware complexity required for enabling the reception of both a pilot signal and a data signal in a GNSS receiver. Figure 5 shows a generic representation of a system within which the present invention operates. As shown in Figure 5, a receiver 500 is located at a particular location on the Earth 510 at a given moment, and a plurality of satellites 520 orbit the Earth 510. Each of the satellites 520 is

capable of transmitting information to the receiver 500, which can receive a number of the signals, possibly with the help of an assistance mechanism 530.

[0019] The circuitry for a typical receiver according to one embodiment of the present invention is shown in Figure 6 in a simplified block diagram. The electronic device 1 of Figure 6 comprises, for example, a positioning receiver 2 as well as communication mechanism 3 such as an antenna. By this communication mechanism 3, the electronic device 1 may, if necessary, communicate with a communication network such as a mobile communication network. Furthermore, the electronic device 1 comprises a control block 5 which may comprise a processor MCU and/or a digital signal processor DSP. For the use, the electronic device 1 is provided with at least one user interface 6, comprising a display 7, a keypad 8 and audio system components 9a, 9b, 9c in one embodiment of the invention. For storing data and application software, the electronic device 1 is provided with a memory unit 10. Individual circuits and elements are all of a type well known in the art, for example in the Nokia range of mobile telephones. The receiver 500 of the present invention can be incorporated into devices such as a mobile telephone. The present invention can also be incorporated into a variety of other devices.

[0020] As discussed previously, Figure 1 is a representation of a conventional GNSS receiver correlation channel 100 that is used to track a single satellite channel. Input data from an analog-to-digital converter (not shown) is input to the correlation channel 100. This data is subject to an initial multiplier 105, as well as an early multiplier 107, a late multiplier 109 and a prompt multiplier 111. After being subject to these multipliers, the data is subject to a corresponding early integrate-dump block 113, late integrate-dump block 115 and prompt integrate-dump block 117, respectively. Each pair of multipliers and integrate-dump blocks work to correlate the signal, which is then transmitted for subsequent carrier tracking and data extraction 110 and code tracking 120. Both the carrier tracking and data extraction 110 and the code tracking 120 typically are performed in the software of the receiver 500. The carrier tracking and data extraction 110 ultimately produces message data for use, while the combination of the carrier tracking and data extraction 110 and the code tracking 120 produces measurement data for use. The correlation channel 100 also

includes a carrier numerically controlled oscillator (NCO) 130, as well as a code NCO 140. The code NCO 140 generates the code rate clock signal for a code generator 150. The code from the code generator 150 is then fed to a delay line composed of a plurality of delay elements 160, which construct early, late and prompt versions of the generated code for subsequent correlation.

[0021] One embodiment of the present invention is depicted in Figure 3. Figure 3 shows an optimized and combined receiver correlation channel architecture 300 that can be used for the simultaneous reception of data. In the optimized receiver correlation channel architecture 300, one complete correlation channel 310 has been implemented. This correlation channel 310 is similar to the correlation channel 100 depicted in Figure 1. The correlation channel 310 is used to track the pilot signal. A pilot code generator 315 is used to generate pilot data code based upon the code rate clock signal received from the code NCO 140.

[0022] In addition, the optimized receiver architecture 300 of Figure 3 includes a data signal replica code generator 320. The code is removed or wiped off from the received signal by multiplying the incoming signal with correctly aligned locally generated replica code. A data signal multiplier 325 and a data integrate-dump block 335 are used to form the code-correlated data signal. Block 330 performs demodulation, symbol and frame synchronization on the code-correlated data signal in order to recover the message data 340 transmitted by the satellite 520 whose signal is being received. The data signal replica code generator 320 can be controlled by the associated pilot signal tracking loop 350, because the signals are generated at the satellite 520 using a single frequency reference, and the carrier frequency of both signals is the same (leading to identical atmospheric delays). If slightly different carrier frequencies are used for the pilot and data signals, two replicas of the carriers would also be generated. These carriers can be generated using the same concept as is used for the replica code. In this embodiment of the invention, information from the pilot signal is used to track both the pilot signal and the data signal from the respective satellites 520. In this system, only the demodulation of the data signal is necessary, and the hardware for tracking the data signal is not necessary.

[0023] A second embodiment of the present invention is depicted in Figure 4. The architecture 400 of Figure 4, like the embodiment shown in Figure 3, includes a separate data signal replica code generator 320 and pilot code generator 315 with a correlation channel which is otherwise substantially identical to the correlation channel of Figure 1. In the embodiment shown in Figure 4, however, no separate correlator for the data signal is necessary. A software controllable switch 430 selects between the pilot and data codes. It should also be noted that the separate data signal replica code generator and pilot code generator 320 and 315 and the software controllable switch 430 can be built into a single configurable code generator. Again, if slightly different carrier frequencies are utilized, two switchable carrier replica generators are also required. The tracking software observes the signal level during tracking. This can also be accomplished through the use of tracking hardware. If the level is high enough to allow decoding of the data bits in the data signal, then the tracking is switched. The switching can be performed on the fly because the signals are generated at the satellite 520 using a single frequency reference, and the carrier frequency of both signals is the same (leading to identical atmospheric delays) and both carrier and code phases are known for both the pilot and data signals at all times during tracking of either signal. It is also possible to shut down the unused code generator altogether for the time that is not being used for the aforementioned reasons in order to save power that is needed for operating the receiver. The monitoring of the signal level continues at all times, and if the signal level drops below a threshold for reliable data decoding, the tracking switches back to the pilot signal. It is also possible to switch back to the pilot signal when the signal level is high if the data message is not needed for some reason, e.g. the complete message is already downloaded or the receiver 520 has received the same data by another means such as assistance.

[0024] When the receiver 500 begins to search for the satellite signal, there is no need for the data signal receiving parts, as the pilot signal has been designed for superior acquisition performance. With low signal to noise ratios, the data message cannot be received, since the reception requires a certain signal-to-noise ratio (SNR) which is higher than the SNR threshold for tracking. Again, the data signal reception

capability is not needed at all. Low SNRs are increasingly common for normal GNSS operation due to requirements for indoor and urban canyon conditions. In many instances, the GNSS receiver 500 can also obtain the satellite data message through more robust communication channels as an assistance mechanism 530, which also makes the need for receiving the data signal unnecessary. However, if the receiver 500 needs to operate in stand-alone mode within “normal” conditions, i.e. the signal level is relatively high, the data signal needs to be received to allow the receiver 500 to produce location information to the user. On the other hand, in such situations using the data signal for tracking after acquisition can provide almost as good measurements as using the pilot signal; therefore the pilot signal is not needed in such cases. Thus, it is generally sufficient to be able to receive one of the two signals at a time, but the capability to receive both signals is still required.

[0025] The present invention is described in the general context of method steps, which may be implemented in one embodiment by a program product including computer-executable instructions, such as program code, executed by computers in networked environments.

[0026] Generally, program modules include routines, programs, objects, components, data structures, etc. that perform particular tasks or implement particular abstract data types. Computer-executable instructions, associated data structures, and program modules represent examples of program code for executing steps of the methods disclosed herein. The particular sequence of such executable instructions or associated data structures represent examples of corresponding acts for implementing the functions described in such steps.

[0027] Software and web implementations of the present invention could be accomplished with standard programming techniques with rule based logic and other logic to accomplish the various database searching steps, correlation steps, comparison steps and decision steps. It should also be noted that the words “component” and “module” as used herein, and in the claims, is intended to encompass implementations using one or more lines of software code, and/or hardware implementations, and/or equipment for receiving manual inputs.

[0028] The foregoing description of embodiments of the present invention have been presented for purposes of illustration and description. It is not intended to be exhaustive or to limit the present invention to the precise form disclosed, and modifications and variations are possible in light of the above teachings or may be acquired from practice of the present invention. The embodiments were chosen and described in order to explain the principles of the present invention and its practical application to enable one skilled in the art to utilize the present invention in various embodiments and with various modifications as are suited to the particular use contemplated.

WHAT IS CLAIMED IS:

1 1. A method of using a receiver to process multiple signals on a common
2 carrier frequency, comprising:
3 having the receiver receive input data transmitted from a remote
4 source;
5 tracking a first signal from the input data using a correlation channel;
6 and
7 decoding a second signal from the input data using a code wipe-off
8 mechanism operatively connected to the first correlation channel.

1 2. The method of claim 1, wherein the code wipe-off mechanism includes
2 a generator which generates replica code for the second signal to a correlator, and
3 wherein the correlator despreads the second signal.

1 3. The method of claim 2, wherein the generator is positioned within the
2 correlation channel.

1 4. The method of claim 1, wherein the second signal is used in the
2 computation of location information for the receiver.

1 5. The method of claim 1, wherein the second signal is used to provide
2 communication information to a user of the receiver.

1 6. The method of claim 1, wherein the first signal comprises a pilot signal
2 and the second signal comprises a data signal.

1 7. A method of using a receiver to process multiple signals on a common
2 carrier frequency from a satellite, comprising the steps of:
3 having the receiver receive input data transmitted from the satellite;
4 if the signal-to-noise ratio of the input data does not meet or exceed a
5 predetermined threshold, using a first code generator to track the input data using a
6 first signal in the input data; and

7 if the signal-to-noise ratio of the input data meets or exceeds the
8 predetermined threshold, using a second code generator to track the input data using a
9 second signal in the input data,

10 wherein the receiver is capable of switching between the first code
11 generator and the second code generator based upon the signal-to-noise ratio of the
12 input data.

1 8. The method of claim 7, further comprising the step of, if the receiver
2 has already downloaded message data included within the input data, using the first
3 code generator to track the input data.

1 9. A computer program product for using a receiver to process multiple
2 signals on a common carrier frequency from a satellite, comprising:

3 computer code for having the receiver receive input data transmitted
4 from a remote source;

5 computer code for tracking a first signal from the input data using a
6 correlation channel; and

7 computer code for decoding a second signal from the input data using a
8 code wipe-off mechanism operatively connected to the first correlation channel.

1 10. The computer program product of claim 9, wherein the code wipe-off
2 mechanism includes a generator which generates replica code for the second signal to
3 a correlator, and wherein the correlator despreads the second signal.

1 11. The computer program product of claim 10, wherein the generator is
2 positioned within the correlation channel.

1 12. The computer program product of claim 9, wherein the second signal is
2 used in the computation of location information for the receiver.

1 13. The computer program product of claim 9, wherein the second signal is
2 used to provide communication information to a user of the receiver.

1 14. The computer program product of claim 9, wherein the first signal
2 comprises a pilot signal and the second signal comprises a data signal.

1 15. A computer program product for using a receiver to process multiple
2 signals on a common carrier frequency from a satellite, comprising the steps of:
3 computer code for having the receiver receive input data transmitted
4 from the satellite;
5 computer code for, if the signal-to-noise ratio of the input data does not
6 meet or exceed a predetermined threshold, using a first code generator to track the
7 input data using a first signal in the input data; and
8 computer code for, if the signal-to-noise ratio of the input data meets
9 or exceeds the predetermined threshold, using a second code generator to track the
10 input data using a second signal in the input data,
11 wherein the receiver is capable of switching between the first code
12 generator and the second code generator based upon the signal-to-noise ratio of the
13 input data.

1 16. The computer program product of claim 15, further comprising
2 computer code for, if the receiver has already downloaded message data included
3 within the input data, using the first code generator to track the input data.

1 17. A receiver to process multiple signals on a common carrier frequency
2 from a satellite, comprising:
3 a first code generator positioned within a correlation channel, the first
4 code generator configured to track a first signal from input data; and
5 a second code generator operatively connected to the first code
6 generator, the second code generator configured to track a second signal from the
7 input data,
8 wherein if the signal-to-noise ratio of the input data does not meet or
9 exceed a predetermined threshold, the first code generator tracks the input data using
10 the first signal in the input data, and wherein if the signal-to-noise ratio of the input

11 data meets or exceeds the predetermined threshold, the second code generator tracks
12 the input data using the second signal in the input data.

1 18. The receiver of claim 17, wherein the receiver is capable of switching
2 between the first code generator and the second code generator based upon the signal-
3 to-noise ratio of the input data..

1 19. The receiver of claim 17, wherein the second signal is used in the
2 computation of location information for the receiver.

1 20. The receiver of claim 17, wherein the second signal is used to provide
2 communication information to a user of the receiver.

1 21. The receiver of claim 17, wherein the second code generator transmits
2 replica code for the second signal to a correlator, and wherein the correlator despreads
3 the second signal.

1 22. A mobile telephone including a GNSS receiver, comprising:
2 a processor;
3 a memory unit operatively connected to the processor;
4 a first code generator positioned within a correlation channel, the first
5 code generator configured to track a first signal from input data; and
6 a second code generator operatively connected to the first code
7 generator, the second code generator configured to track a second signal from the
8 input data,

9 wherein if the signal-to-noise ratio of the input data does not meet or
10 exceed a predetermined threshold, the first code generator tracks the input data using
11 the first signal in the input data, and wherein, if the signal-to-noise ratio of the input
12 data meets or exceeds the predetermined threshold, the second code generator tracks
13 the input data using the second signal in the input data.

1 23. The mobile telephone of claim 22, wherein the receiver is capable of
2 switching between the first code generator and the second code generator based upon
3 the signal-to-noise ratio of the input data.

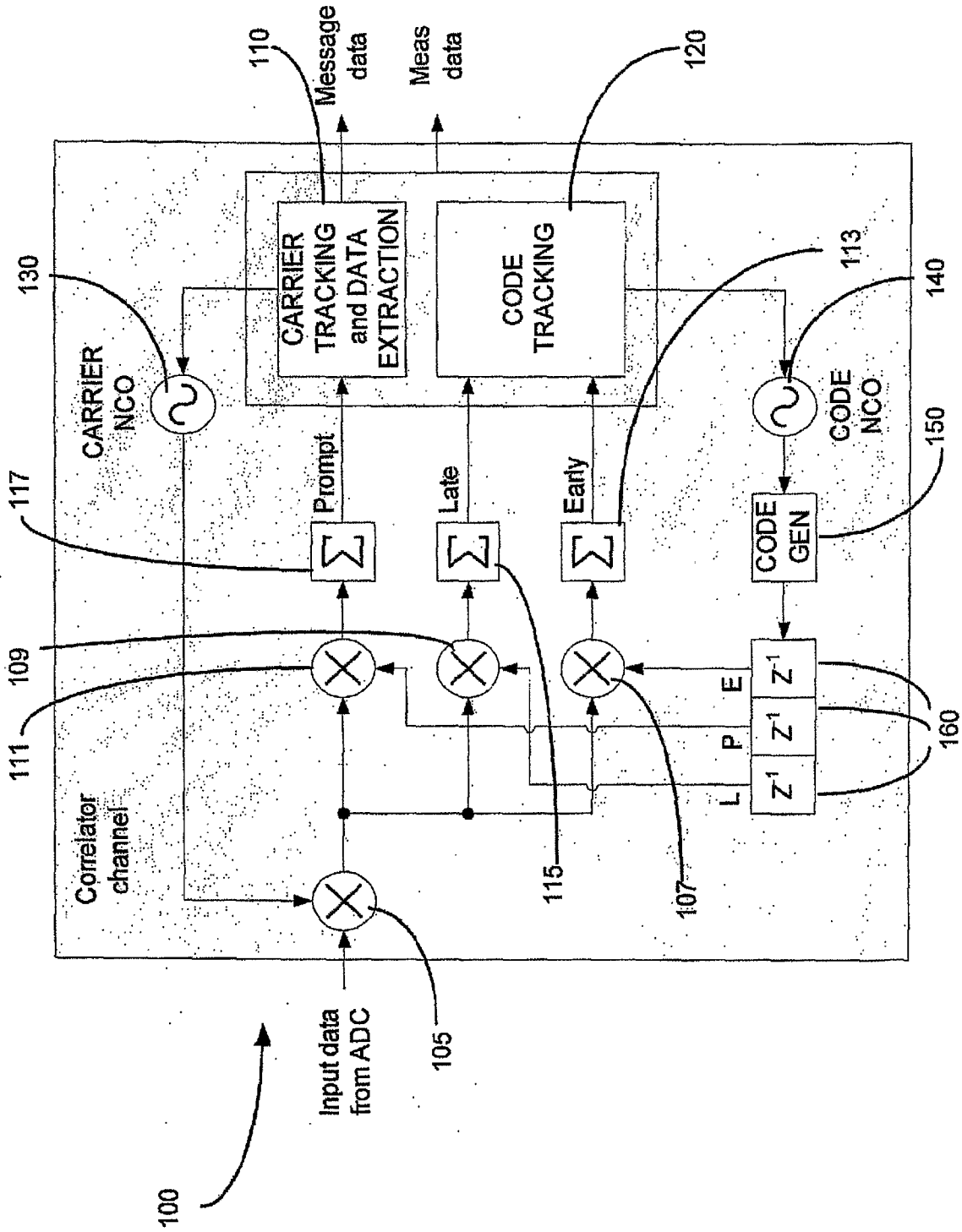

FIG. 1

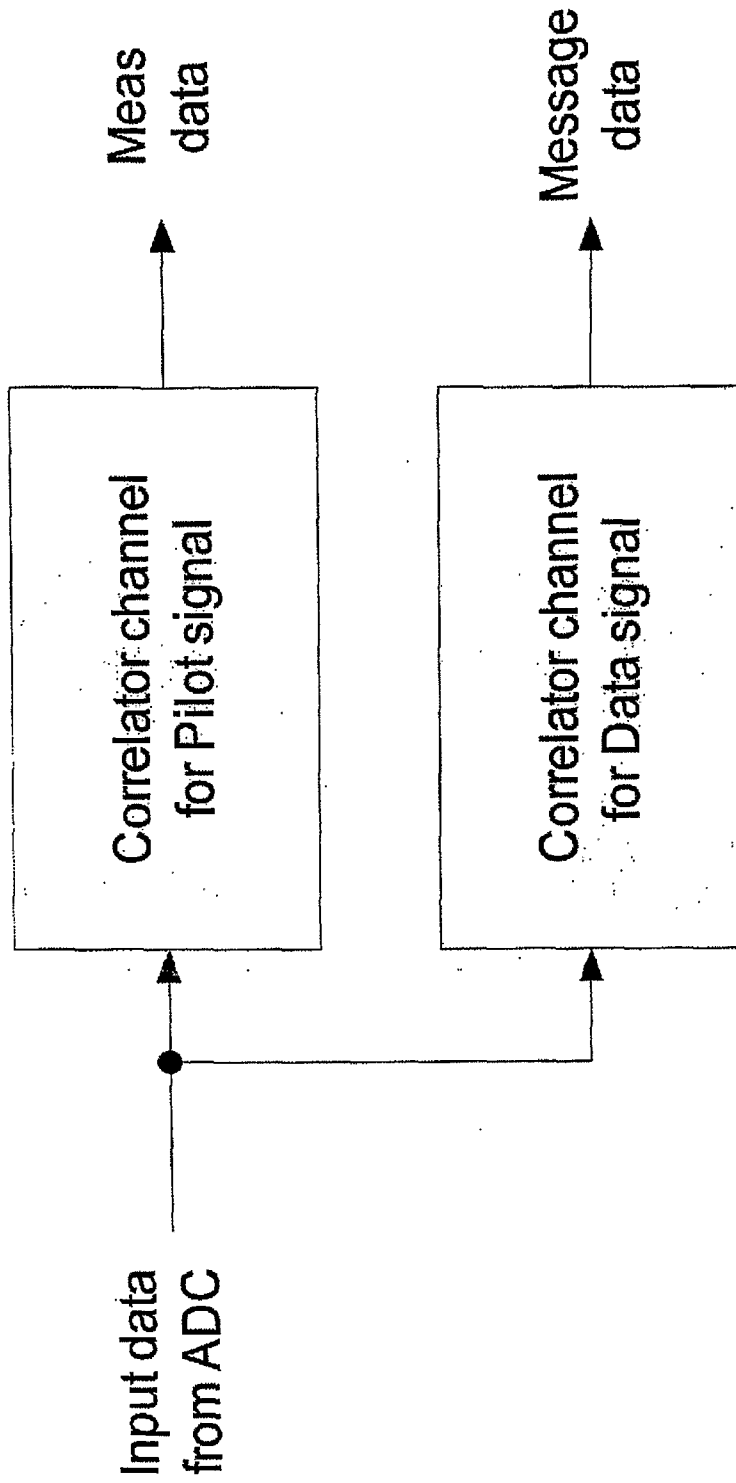

FIG. 2

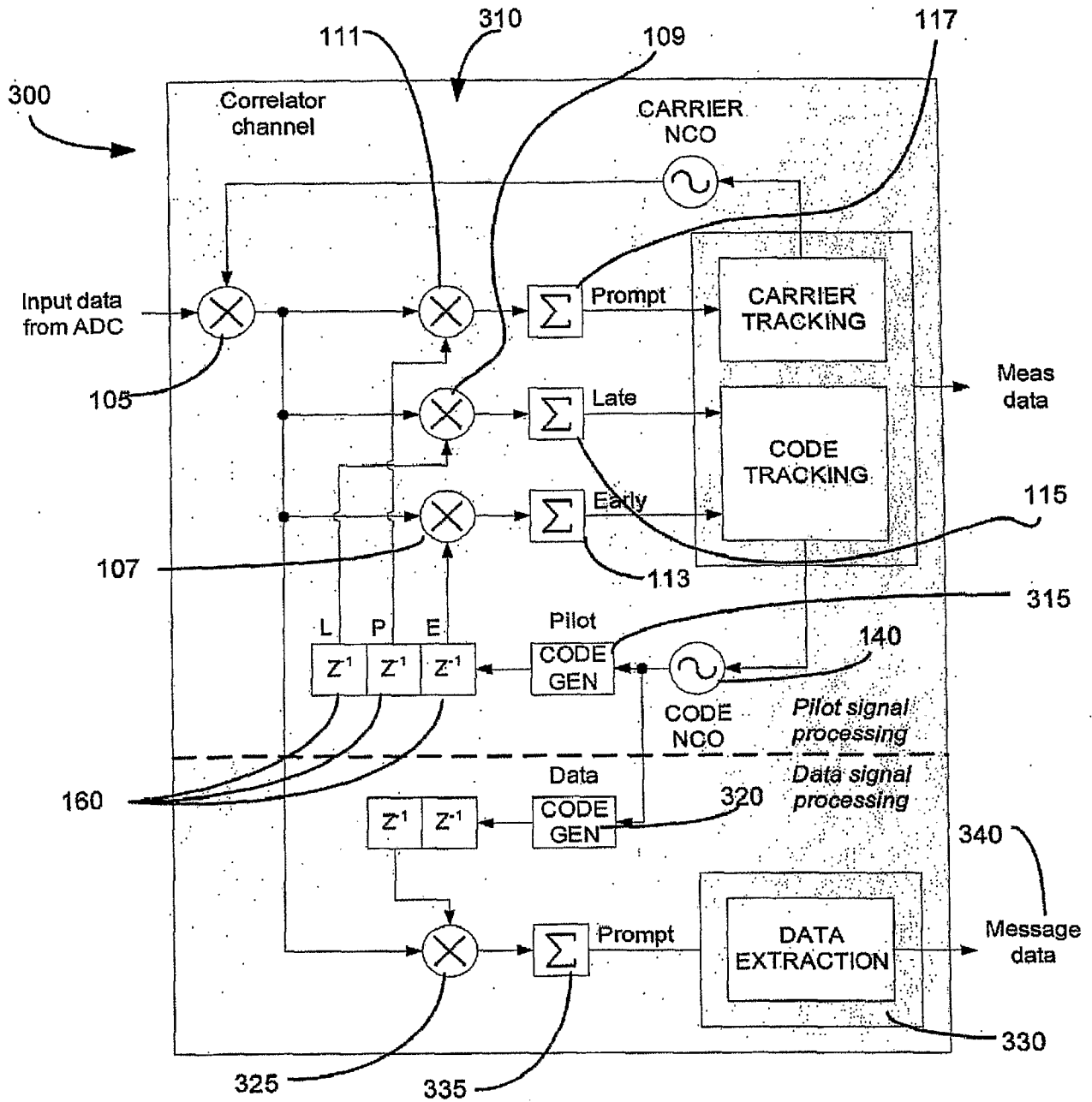

FIG. 3

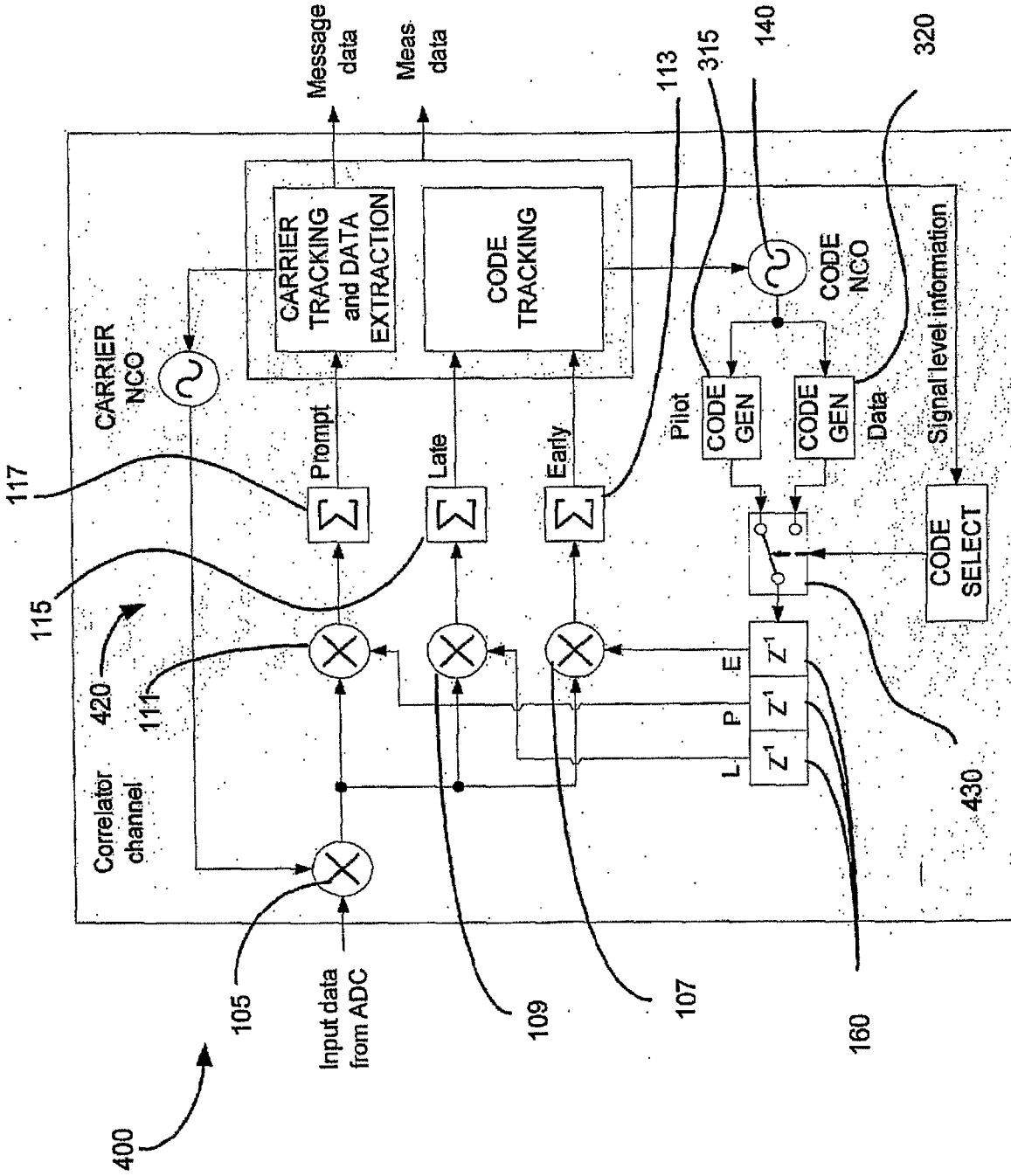

FIG. 4

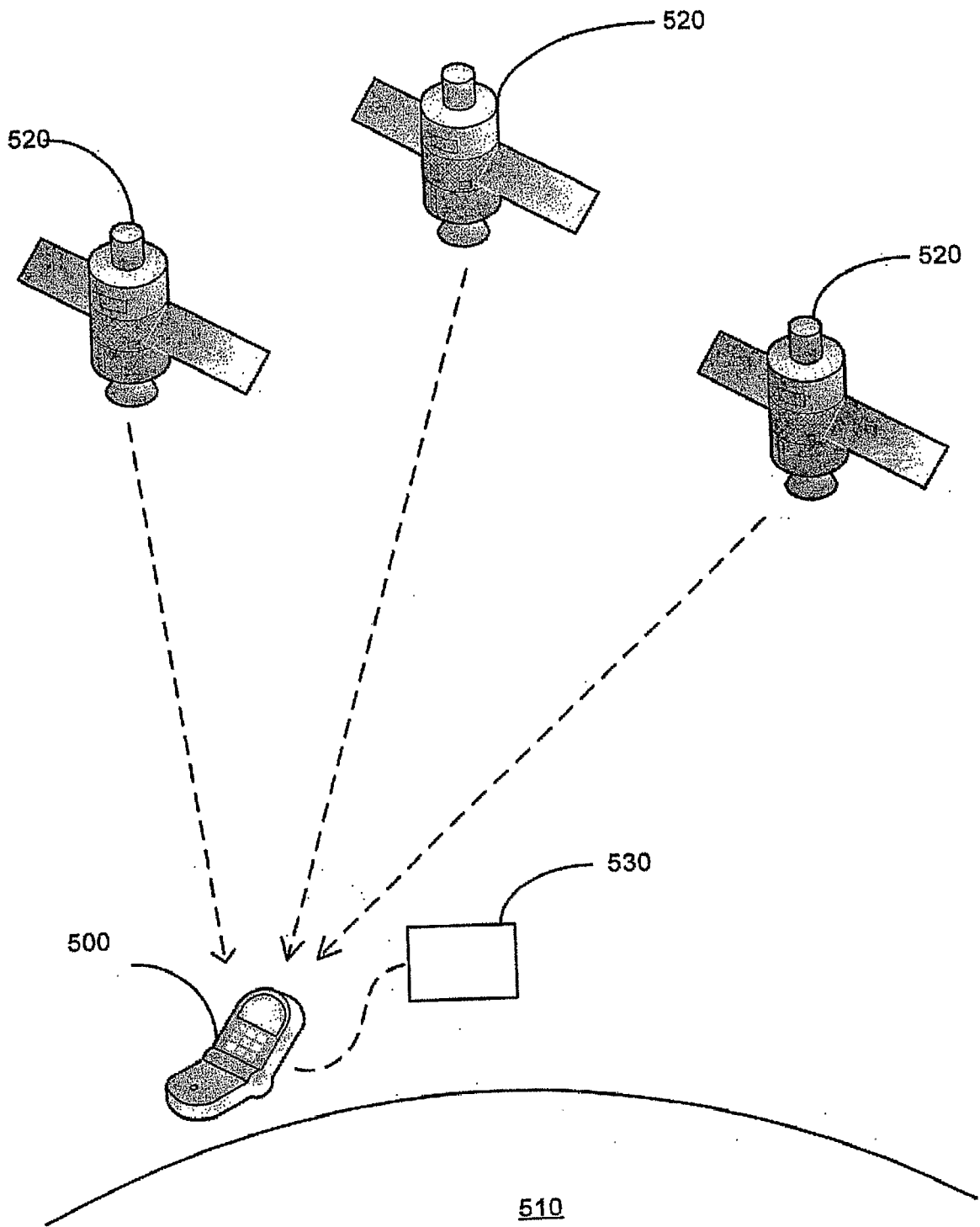

FIG. 5

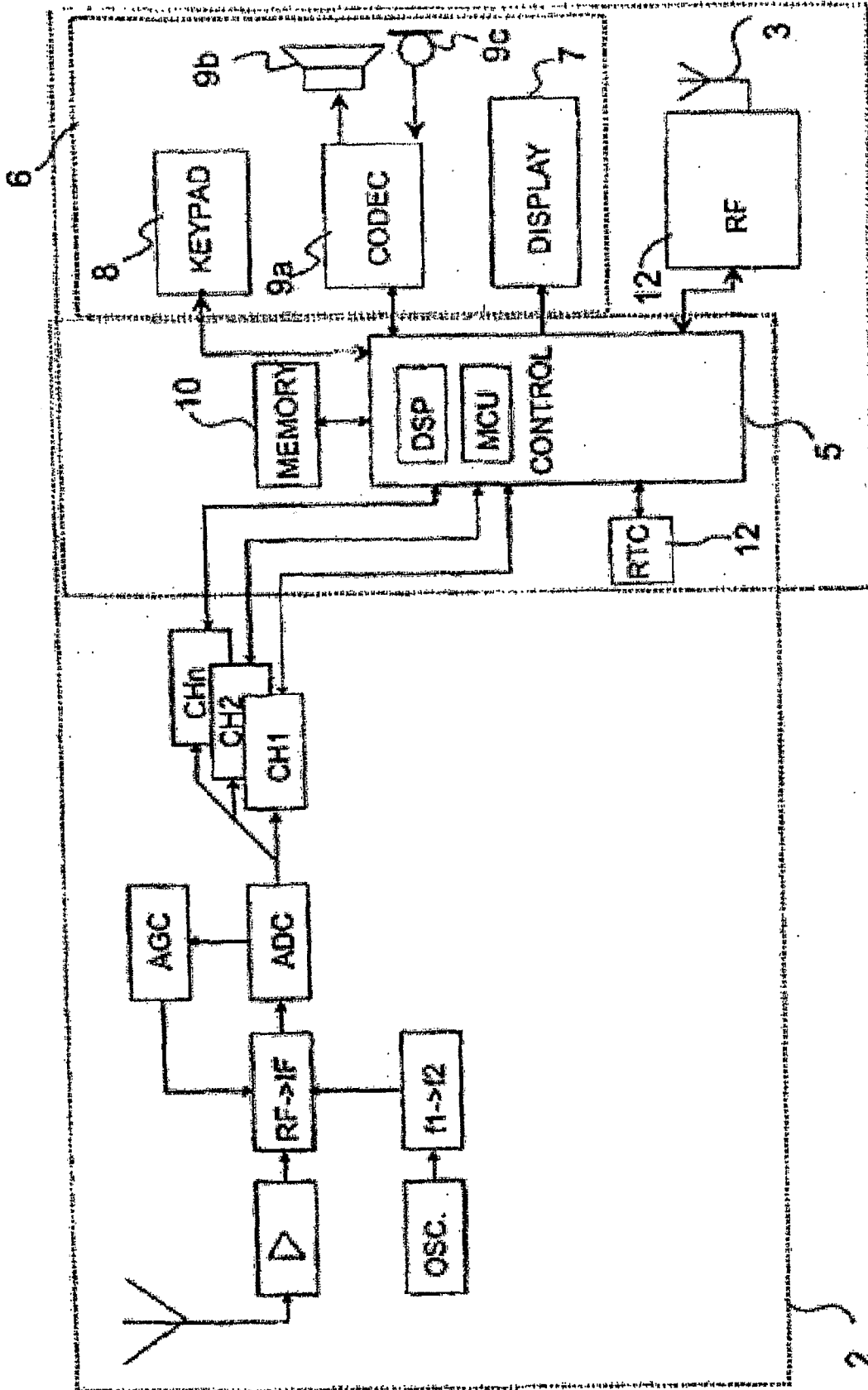

FIG 6

INTERNATIONAL SEARCH REPORT

International application No.

PCT/IB2006/001793

A. CLASSIFICATION OF SUBJECT MATTER

IPC: see extra sheet

According to International Patent Classification (IPC) or to both national classification and IPC

B. FIELDS SEARCHED

Minimum documentation searched (classification system followed by classification symbols)

IPC: G01S, H04B

Documentation searched other than minimum documentation to the extent that such documents are included in the fields searched

SE,DK,FI,NO classes as above

Electronic data base consulted during the international search (name of data base and, where practicable, search terms used)

EPO-INTERNAL, WPI DATA, PAJ

C. DOCUMENTS CONSIDERED TO BE RELEVANT

Category*	Citation of document, with indication, where appropriate, of the relevant passages	Relevant to claim No.
X	WO 2005006012 A1 (CENTRE NATIONAL DETUDES SPATIALES), 20 January 2005 (20.01.2005), page 2, line 29 - page 3, line 3; page 9, line 1 - page 11, line 14, figures 1-4, abstract	1-6,9-14
A	--	7,8,15-23
A	US 20050012664 A1 (NEIL GEREIN), 20 January 2005 (20.01.2005), figure 3, abstract	1-23
	-- -----	

 Further documents are listed in the continuation of Box C. See patent family annex.

* Special categories of cited documents:

"A" document defining the general state of the art which is not considered to be of particular relevance

"E" earlier application or patent but published on or after the international filing date

"L" document which may throw doubts on priority claim(s) or which is cited to establish the publication date of another citation or other special reason (as specified)

"O" document referring to an oral disclosure, use, exhibition or other means

"P" document published prior to the international filing date but later than the priority date claimed

"T" later document published after the international filing date or priority date and not in conflict with the application but cited to understand the principle or theory underlying the invention

"X" document of particular relevance: the claimed invention cannot be considered novel or cannot be considered to involve an inventive step when the document is taken alone

"Y" document of particular relevance: the claimed invention cannot be considered to involve an inventive step when the document is combined with one or more other such documents, such combination being obvious to a person skilled in the art

"&" document member of the same patent family

Date of the actual completion of the international search

17 November 2006

Date of mailing of the international search report

24-11-2006

Name and mailing address of the ISA/

Swedish Patent Office
Box 5055, S-102 42 STOCKHOLM
Facsimile No. +46 8 666 02 86

Authorized officer

Göran Magnusson/MP
Telephone No. +46 8 782 25 00

International patent classification (IPC)**G01S 1/00 (2006.01)****Download your patent documents at www.prv.se**

The cited patent documents can be downloaded at www.prv.se by following the links:

- In English/Searches and advisory services/Cited documents (service in English) or
- e-tjänster/anförda dokument (service in Swedish).

Use the application number as username.

The password is **PJSXKQZPJT**.

Paper copies can be ordered at a cost of 50 SEK per copy from PRV InterPat (telephone number 08-782 28 85).

Cited literature, if any, will be enclosed in paper form.

INTERNATIONAL SEARCH REPORT
Information on patent family members

01/11/2006

International application No.
PCT/IB2006/001793

WO	2005006012	A1	20/01/2005	CA	2529197 A	20/01/2005
				CN	1806183 A	19/07/2006
				EP	1634097 A	15/03/2006
				FR	2856143 A,B	17/12/2004

US	20050012664	A1	20/01/2005	US	6922167 B	26/07/2005
				AU	2003280530 A	00/00/0000
				BR	PI0318397 A	01/08/2006
				CA	2530616 A	20/01/2005
				CN	1802572 A	12/07/2006
				EP	1644753 A	12/04/2006
				RU	2005140737 A	27/08/2006
				WO	2005006011 A	20/01/2005
