

W. C. BAIRD.
SPEED CONTROLLING DEVICE.

No. 449,063.

Patented Mar. 24, 1891.

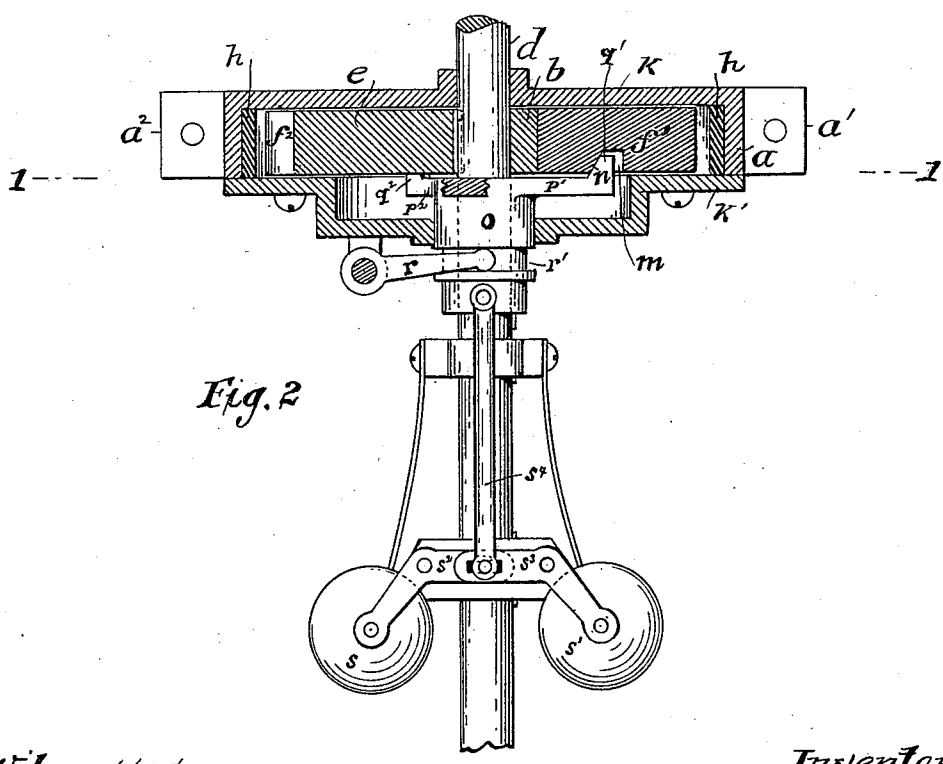
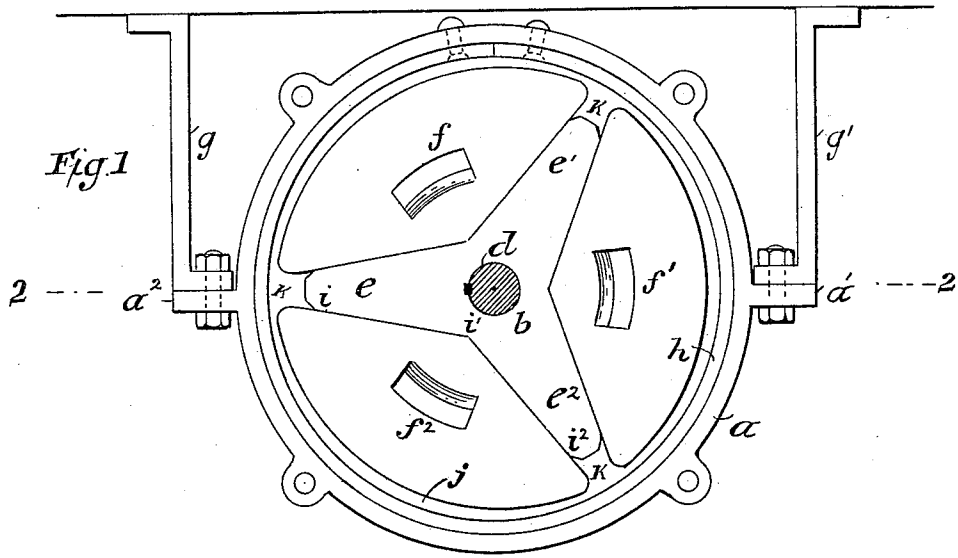

Witnesses
J. E. Greer
Fred Kemper

Inventor
William C. Baird
 by *Efford & Law*
Atty's.

W. C. BAIRD.
SPEED CONTROLLING DEVICE.

No. 449,063.

Patented Mar. 24, 1891.

Fig 3

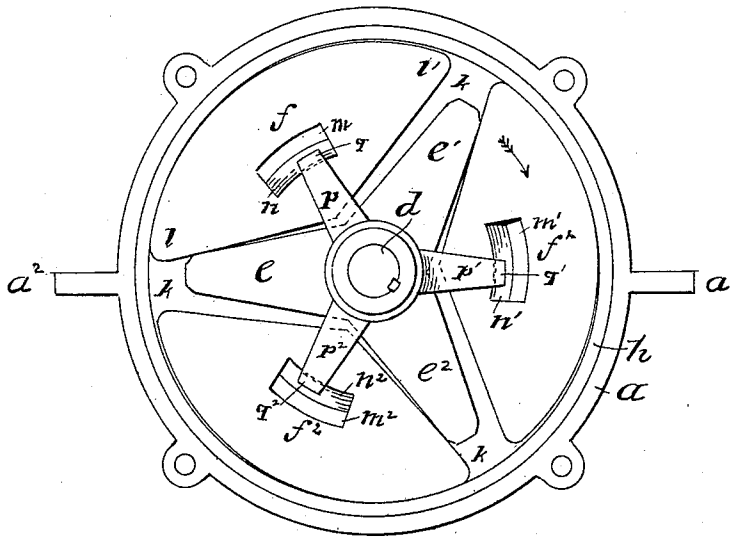

witnesses,

J. E. Green
Fred Kumpfer

Inventor

William C. Baird
by Efford & Law
Attys

UNITED STATES PATENT OFFICE.

WILLIAM C. BAIRD, OF BROOKLYN, NEW YORK, ASSIGNOR TO THE WILSON MANUFACTURING COMPANY, OF MINNESOTA.

SPEED-CONTROLLING DEVICE.

SPECIFICATION forming part of Letters Patent No. 449,063, dated March 24, 1891.

Application filed June 21, 1890. Serial No. 356,187. (No model.)

To all whom it may concern:

Be it known that I, WILLIAM C. BAIRD, of Brooklyn, in the county of Kings and State of New York, have invented a new and useful Improvement in Speed-Controlling Devices, of which the following is a specification.

The object of my invention is to provide mechanism whereby the speed of a rotating shaft may be retarded, and other mechanism whereby the retarding influence of the first-named mechanism may be controlled so as to be applied automatically or otherwise.

In the drawings I have shown my invention applied to a shaft without illustrating the prime mover of the shaft, which would differ in accordance with the different machines or structures in which the shaft might be used.

Figure 1 is a view from a position in line with the axis of the shaft, the parts below the line 1 1 of Fig. 2 being removed from the retarder to display the internal arrangement of the parts. Fig. 2 is a view, partly in section, from a position at one side of the shaft. Fig. 3 is the same thing as Fig. 1, plus the sleeve and arm, excepting that the parts are shown in the position which they occupy when in operation, whereas in Fig. 1 they are shown in the position which they occupy when not in operation.

The retarder consists of the following: A stationary ring *a*, concentric with the shaft, and a hub *b*, fast on the shaft *d*, from which extend radially one or more arms, as *e e' e''*. *f f' f''* are one or more sector-shaped blocks. The ring *a* may be provided with the lugs *a' a''* for securing it to the frame by suitable supports or hangers *g g'*. This ring may be lined by a facing *h* of leather or other material adapted to sustain friction. The hub *b* is preferably provided with three arms, each of which, as the arm *e*, extends radially toward the leather *h*. The distance between the end of each arm and the leather *h* will be determined by the retarding power which is required of the instrument. The angle *i i' i''*, formed by the adjacent sides of each two of the arms, is preferably as shown in Fig. 1, especially near the ends of the arms, where the cam action herein-after referred to takes place. Within this angle is the sector-shaped block *f''*, the radius

of which, taken from the center of the shaft *d*, is, however, less than the internal radius of the friction-surface *h*, so that when the block *f''* lies in the angle *i i' i''* in contact with the arms *e e''* there will be a clear space *j* between the periphery of the block *f''* and the friction-surface. The block *f''* lies loosely in the angle *i i' i''*, so that when the said block *f''* is in operation it is free to have radial movement out against the friction-surface *h* and is restrained from axial movement by the face-plates *k* and *k'*, which are secured to the stationary ring *a*.

The parts already described are sufficient for the operation of the retarder, the parts to be hereinafter described being intended for controlling the action of the retarder.

When in operation, the friction-block of the retarder acts substantially as shown in Fig. 3—that is to say, as soon as the hub *b* commences to revolve in the direction of the arrow the extremity of the arm *e* will act as a cam upon the surface of the block *f*, with which it is in contact, and force that block from the position shown in Fig. 1 to the position shown in Fig. 3, in which last position the rearward point *l* of the block *f* is wedged between the extremity of the arm *e* and the friction-surface *h*, so that as the arm *e* carries the friction-block *f* around in front of it the rearward point *l* of the friction-block is pressed firmly against the friction-surface *h*, and this pressure and the consequent friction increase automatically as the force tending to revolve the arm *e* increases. Thus the force of retardation increases automatically as the demands upon it increase in opposition to any force which may be tending to drive the shaft *d* to an abnormally great velocity. Each of the friction-blocks *f f' f''* will co-operate with each of the arms *e e' e''* in substantially the same manner.

This retarder will operate equally well in the reverse direction, the operation of the parts being substantially the same, only reversed.

I have combined with the retarder, operating upon the principle above described, mechanism whereby its retarding influence may be utilized only when required, at other times the shaft *d* running freely without any ob-

struction from the retarder; and although I do not wish to limit myself to any particular mechanism (of which many forms might be used in effecting this combination) I will proceed to describe the form which I at present deem best adapted.

In the friction-block f , and likewise each of the other friction-blocks, is sunk a recess m , forming the arc of a circle from the center of shaft d . The wall n of this recess toward the shaft is inclined, as shown in Fig. 2. o is a sleeve splined to the shaft, so as to be capable of axial movement. Connected with this sleeve are the radial arms $p p' p^2$. Upon the extremity of the arm p' , and likewise of the other arms, is a finger q' , having an incline on its side toward the shaft corresponding with the inclined wall n . Connected with the sleeve o may be the shifter-lever r , adapted to be operated by hand and engaging with the circular groove r' in the sleeve o , so as to admit of the rotation of the sleeve with the shaft. When now it is desired to throw the friction-block of the retarder out of operation, the sleeve o may be shoved by the shifter r toward the retarder, so that the inclines on the fingers $q q' q^2$ will act upon the inclined walls $n n' n^2$ and draw the friction-blocks $f f' f^2$ toward the center, bringing them to the position shown in Fig. 1 and holding them there, and thus preventing any such action as is illustrated in Fig. 3. Under these conditions the arms $e e' e^2$ and the blocks $f f' f^2$ will revolve as in one piece with the shaft and will have no frictional contact with the friction-surface h . If now it be desired to utilize the retarder, the sleeve o is shoved back, so that the friction-blocks $f f' f^2$ are relieved from the action of the fingers $q q' q^2$ and are free to operate on the principle illustrated in Fig. 3.

In lieu of the shifter-lever r , operated by hand, a device may be employed for performing the same function, but operated automatically by the speed of the shaft, so as to throw the friction-block of the retarder into operation whenever the speed of the shaft exceeds a certain limit. Such a device is illustrated in Fig. 2 in the form of a well-known governor containing the revolving weights $s s'$, connected by the levers $s^2 s^3$ and the link s^4 with the sleeve o , so that when the shaft revolves the weights beyond a certain degree of velocity their centrifugal force will act to pull the

sleeve o back from the retarder and release the blocks $f f' f^2$ in the manner already described.

As one of the forms of mechanism which may be employed in lieu of the form above described for preventing the operation of the retarder, the following may be mentioned, namely: Instead of being mounted upon the main shaft d , the retarder may be mounted upon a counter-shaft, which is driven from the main shaft by any suitable connecting mechanism, and in this connecting mechanism may be introduced a means of disconnection controlled either by a hand-lever or by a governor, so that the counter-shaft and retarder may remain motionless until started by throwing the mechanism connecting the two shafts into gear.

I claim—

1. In combination, a friction-ring and an arm, respectively fixed and movable about an axis relatively to one another, a piece adapted to wedge between the arm and the friction-ring when the parts are in motion, and mechanism whereby said piece may be withheld from its wedging position, substantially as described.

2. In combination, a fixed friction-ring, a rotatable arm, a block carried around by the rotation of the arm and adapted to wedge between the arm and the friction-ring, and mechanism whereby the block may be held toward the center so as to be inoperative, substantially as described.

3. In combination, a rotatable arm, a fixed friction-ring, a block adapted to wedge between the two, mechanism whereby said block may be withheld from its wedging position, and a governor controlling said last-mentioned mechanism by the speed of the machine, substantially as described.

4. A rotatable shaft and a retarder having an arm fixed to the shaft and a friction-block, by the co-operation of which the latter is wedged against the friction-ring, in combination with a sleeve on the shaft, and a finger connected with said sleeve, whereby the friction-block is held away from the friction-ring when the retarder is not in operation, substantially as described.

WILLIAM C. BAIRD.

Witnesses:

FRED KEMPER,
J. E. GREER.