

J. NIELSEN.
 COLLAPSIBLE WARDROBE.
 APPLICATION FILED JULY 18, 1912.

1,070,717.

Patented Aug. 19, 1913.

2 SHEETS—SHEET 1.

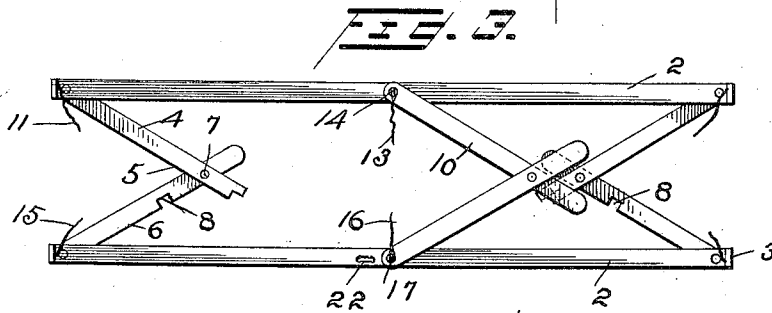
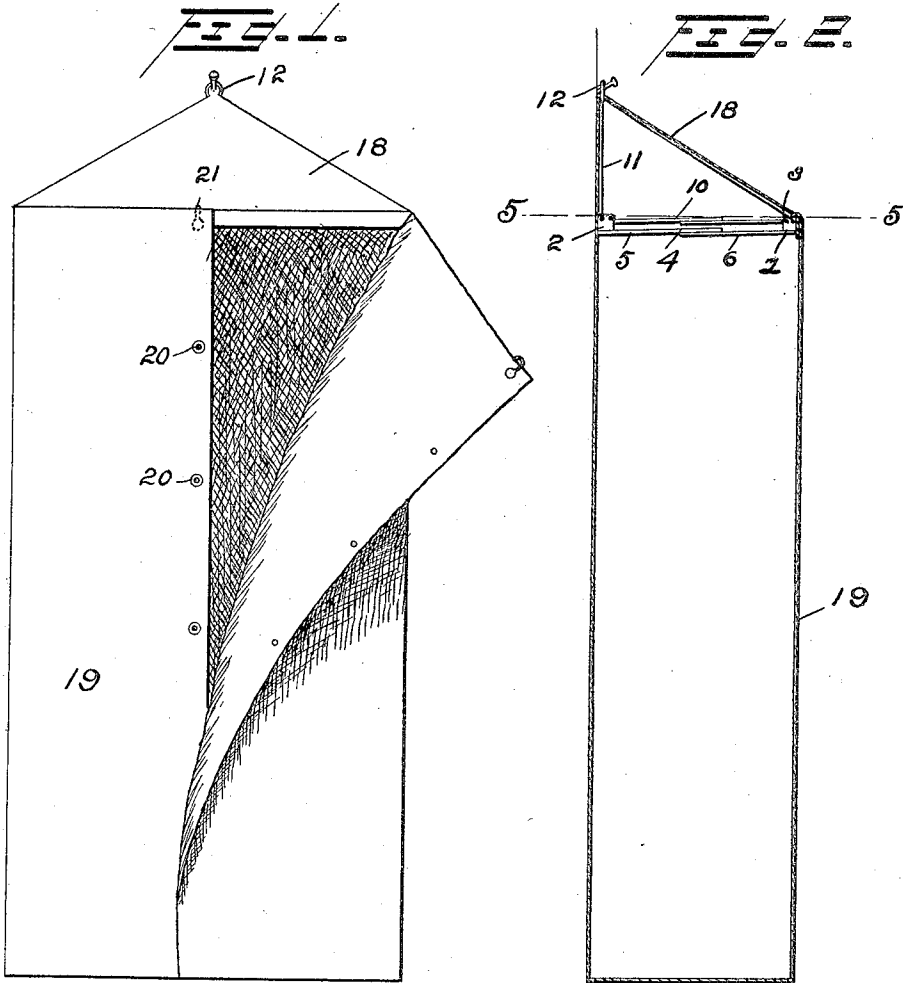

WITNESSES
O. B. Duffy
H. E. Garner

Joe Nielsen INVENTOR
John B. Dupree Attorney

J. NIELSEN.
 COLLAPSIBLE WARDROBE.
 APPLICATION FILED JULY 18, 1912.

1,070,717.

Patented Aug. 19, 1913.

2 SHEETS—SHEET 2.

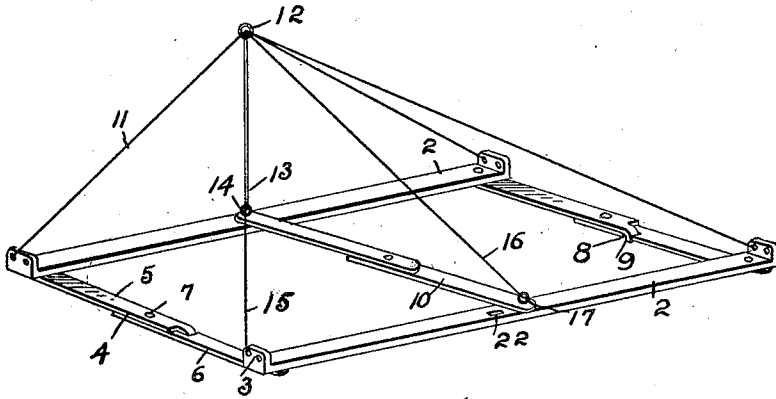

FIG. 4.

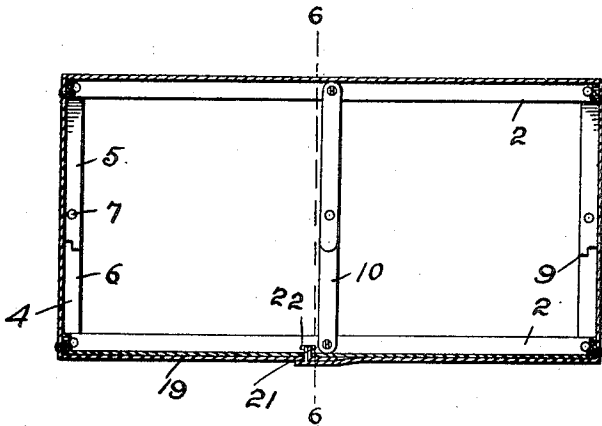

FIG. 5.

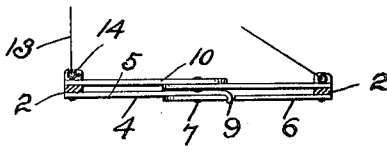

FIG. 6.

WITNESSES

W. C. Duffy
H. E. Garner

Joe Nielsen INVENTOR

John S. Duffell Attorney

UNITED STATES PATENT OFFICE.

JOE NIELSEN, OF LEESBURG, VIRGINIA.

COLLAPSIBLE WARDROBE.

1,070,717.

Specification of Letters Patent. Patented Aug. 19, 1913.

Application filed July 18, 1912. Serial No. 710,156.

To all whom it may concern:

Be it known that I, JOE NIELSEN, a citizen of the United States, residing at Leesburg, in the county of Loudoun and State of Virginia, have invented certain new and useful Improvements in Collapsible Wardrobes, of which the following is a specification.

This invention has relation to collapsible wardrobes, and has for its object to simplify and improve the structure of wardrobes of this character.

A further object of the invention is to provide a wardrobe which may be easily and quickly folded and rolled up and when in its rolled condition may be easily carried in a suitcase or other traveling bag.

With the above objects in view the wardrobe includes a frame which includes in its component parts members adapted to be folded whereby the opposite side portions of the frame may be held together. A series of wires or other flexible members are connected with the frame and may be used as means for supporting the same when the wardrobe is in an extended condition. A cover of peculiar design is arranged upon the frame and is adapted to inclose the articles of clothing that are hung in the wardrobe.

With these and other objects in view, the invention consists in certain novel features of construction as hereinafter shown and described, and then particularly pointed out in the claim and in the drawings illustrative of the preferred embodiment of the invention.

In the accompanying drawings: Figure 1 is a front elevation of the wardrobe. Fig. 2 is a vertical sectional view of the same. Fig. 3 is a plan view of the frame of the wardrobe showing the parts partially collapsed. Fig. 4 is a perspective view of the frame of the wardrobe showing the parts extended. Fig. 5 is a horizontal sectional view of the wardrobe cut on the line 5-5 of Fig. 2. Fig. 6 is a transverse sectional view of the wardrobe cut on the lines 6-6 of Fig. 5.

Corresponding and like parts are referred to in the following description and indicated in all the views of the accompanying drawings by the same reference characters.

The frame of the wardrobe includes front and back bars 2. These bars are preferably made from thin metal and are provided at their ends with upturned extremities 3. The

ends of the bars 2 are connected together by end bars 4. The outer ends of the bars 4 are pivoted to the under sides of the bars 2. The bars 4 are made up of sections 5 and 6 which are pivotally connected together at points 7. The sections 6 are provided at their inner edges and in the vicinity of the pivots 7 with notches 8. The sections 5 are provided at their inner ends with downturned extremities 9 which are adapted to enter the notches 8 and hold the sections 5 and 6 in longitudinal alinement with relation to each other. When the frame of the wardrobe is collapsed the inner ends of the sections 5 and 6 are swung inwardly toward each other as illustrated in Fig. 3. This brings the bars 2 toward each other. Bar sections 10 are pivoted together at their inner end portions at points between their ends and the outer ends of the bar sections 10 and are pivoted to the bars 2 respectively. The bar sections 10 are located mid-way between the ends of the bars 2. When the bars 2 are brought together, the inner ends of the bar sections 10 may be swung toward either of the ends of the bars 2 and when the bar sections 10 are in alinement their end portions overlap each other to such an extent as to press the said bar sections when in horizontal alinement. The manner in which the bar sections 10 overlap each other when in alinement is best illustrated in Figs. 2 and 4 of the drawing. The outer ends of the bar sections 10 rest upon the upper side of the bars 2 so that the bar sections 10 do not interfere with the end sections 5 and 6 when the parts are in folded or collapsed positions.

Relatively short flexible wires 11 are secured at their outer ends to the extremities 3 upon the back bar and the inner ends of the said wires are connected to a ring 12. A relatively short wire 13 is connected at its lower end with an eye 14 provided at a point of pivotal connection between the rear-most bar section 10 and the bar 2. The upper end of the wire 13 is connected to the ring 12. Corner wires 15 are connected at their upper ends with the ring 12 and at their lower ends with the extremities 3 upon the front bar. An intermediate wire 16 is connected at its upper end with the ring 12 and at its lower end with an eye 17 which is provided at the point of pivotal connection between the forward bar section 10 and the front bar. When the frame is hanging

from a support as illustrated in Figs. 1 and 2 the back wires 11 and 13 lie approximately in a vertical plane while the wires 15 and 16 lie in an inclined plane. A curtain is provided for covering the frame to the said wires. Said curtain includes a hood portion 18 which lies upon the wires 11 and 13, 15 and 16. The corners of the said hood portions 18 are connected in any suitable manner with the extremities 3 of the bars 2. The front side of the curtain is extended into flaps 19 and the said flaps are provided with securing devices 20 by means of which the edge portions of the said flaps may be held together. These securing devices may be in the form of glove fasteners or any other means. The flaps 19 are provided with hooks 21 which are adapted to be engaged with an opening 22 provided in the front bar. These hooks serve as means for holding the upper portions of the flaps in closed positions along the outer edge of the bar. The curtain is closed at its lower end as shown in Fig. 2 and in fact constitutes a bag which completely incloses the clothes when they are placed in the wardrobe. When the wardrobe is in position to receive the clothes, the clothes are placed on ordinary clothes hangers which hangers are engaged with the bar sections 10 inasmuch as the weight of the clothes is sustained by the bar sections 10 and the inner ends of the said bar sections overlap each other, the presence of the clothes in the wardrobe has a tendency to hold the end bar sections 5 and 6 in engagement with each other and their inner ends. That is to say when clothes are supported in the wardrobe, it requires considerable pressure or force to swing the inner ends of the bar sections 5 and 6 in an inward direction out of alinement with each other.

Therefore it will be seen that a simple collapsible wardrobe is provided and that the members cooperate with each other to assist in holding the structure in an extended position when clothes are hung in the interior of the said wardrobe.

Having described the invention what is claimed is:

A wardrobe of the type described, including a frame comprising front and rear non-foldable members having apertured upturned end-terminals, one of said members having about centrally thereof, an aperture, a sectional middle-bar member, its sections being pivoted at their outer ends to said front and rear members, respectively, said sections being pivotally connected near their opposite ends, the latter ends being adapted to overlap each other, sectional end-bar members, the sections of each end-bar member being pivotally connected near their inner ends, one end of one section having a downturned portion and the other section having a notch adapted to receive said downturned end portion, said middle-bar and said end-bar members being applied to opposite sides of said front and rear non-foldable members, flexible suspending means for said frame connected to said apertured upturned end-terminals and to connecting means between said middle-bar member and said end bar member, said flexible suspending means including means effecting the convergence of the upper ends thereof, and an inclosure with its upper end applied to, and depending from said frame.

In testimony whereof I affix my signature in presence of two witnesses.

JOE NIELSEN.

Witnesses:

C. M. FORREST,
N. E. GARNER.