

(19) World Intellectual Property Organization  
International Bureau



(43) International Publication Date  
23 February 2012 (23.02.2012)

(10) International Publication Number  
**WO 2012/024285 A1**

- (51) International Patent Classification:  
*E21C 37/16* (2006.01)
- (21) International Application Number:  
PCT/US2011/047902
- (22) International Filing Date:  
16 August 2011 (16.08.2011)
- (25) Filing Language: English
- (26) Publication Language: English
- (30) Priority Data:
 

61/374,594	17 August 2010 (17.08.2010)	US
61/378,910	31 August 2010 (31.08.2010)	US
61/439,970	7 February 2011 (07.02.2011)	US
61/446,312	24 February 2011 (24.02.2011)	US

CO 80209 (US). **RINZLER, Charles, C.** [US/US]; 1015 21st Street, Suite 105, Denver, CO 80205 (US). **UNDERWOOD, Lance, D.** [US/US]; 8767 South Fairall Road, Morrison, CO 80465 (US). **DEUTCH, Paul, D.** [US/US]; 1620 West 13th Street, Houston, TX 77008 (US).

(71) Applicant (for all designated States except US): **FORO ENERGY INC.** [US/US]; 8020 Southpark Circle, Suite 500, Denver, CO 80120 (US).

(72) Inventors; and

(75) Inventors/Applicants (for US only): **DE WITT, Ronald, A.** [US/US]; 20203 Cadogan Court, Katy, TX 77450 (US). **ZEDIKER, Mark, S.** [US/US]; 1896 Via Los Pinons, Castle Rock, CO 80104 (US). **FAIRCLOTH, Brian, O.** [US/US]; 7664 Brook Forest Lane, Evergreen, CO 80439 (US). **GRUBB, Daryl, L.** [US/US]; 7262 Dome Rock Road, Littleton, CO 80125 (US). **MCKAY, Ryan, P.** [US/US]; 8160 West Fremont Avenue, Littleton, CO 80128 (US). **GRAY, William, C.** [US/US]; 10719 Kimball Street, Parker, CO 80134 (US). **MOXLEY, Joel, F.** [US/US]; 949 South Clayton Way, Denver,

(74) Agent: **FREEMAN, John, C.**; BRINKS HOFER GILSON & LIONE, P.O.Box 10087, Chicago, IL 60610 (US).

(81) Designated States (unless otherwise indicated, for every kind of national protection available): AE, AG, AL, AM, AO, AT, AU, AZ, BA, BB, BG, BH, BR, BW, BY, BZ, CA, CH, CL, CN, CO, CR, CU, CZ, DE, DK, DM, DO, DZ, EC, EE, EG, ES, FI, GB, GD, GE, GH, GM, GT, HN, HR, HU, ID, IL, IN, IS, JP, KE, KG, KM, KN, KP, KR, KZ, LA, LC, LK, LR, LS, LT, LU, LY, MA, MD, ME, MG, MK, MN, MW, MX, MY, MZ, NA, NG, NI, NO, NZ, OM, PE, PG, PH, PL, PT, QA, RO, RS, RU, SC, SD, SE, SG, SK, SL, SM, ST, SV, SY, TH, TJ, TM, TN, TR, TT, TZ, UA, UG, US, UZ, VC, VN, ZA, ZM, ZW.

(84) Designated States (unless otherwise indicated, for every kind of regional protection available): ARIPO (BW, GH, GM, KE, LR, LS, MW, MZ, NA, SD, SL, SZ, TZ, UG, ZM, ZW), Eurasian (AM, AZ, BY, KG, KZ, MD, RU, TJ, TM), European (AL, AT, BE, BG, CH, CY, CZ, DE, DK, EE, ES, FI, FR, GB, GR, HR, HU, IE, IS, IT, LT, LU, LV, MC, MK, MT, NL, NO, PL, PT, RO, RS, SE, SI, SK, SM, TR), OAPI (BF, BJ, CF, CG, CI, CM, GA, GN, GQ, GW, ML, MR, NE, SN, TD, TG).

[Continued on next page]

(54) Title: SYSTEMS AND CONVEYANCE STRUCTURES FOR HIGH POWER LONG DISTANCE LASER TRANSMISSION

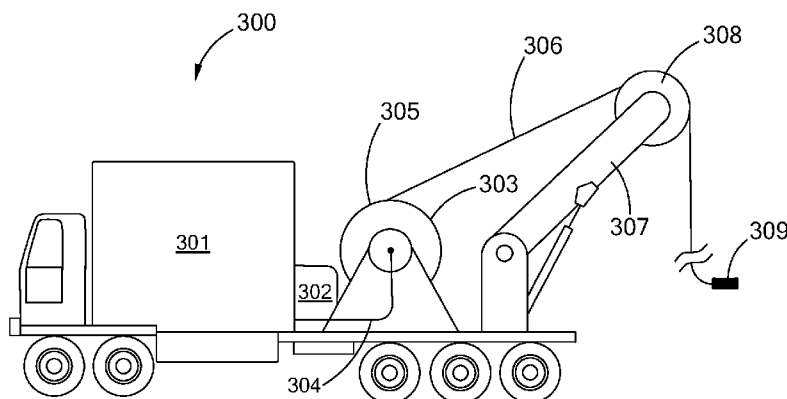

Fig. 3

(57) Abstract: There is provided a mobile high power laser system and conveyance structure for delivering high power laser energy to and for performing high power laser operations in remote and difficult to access locations. There is further provide such systems with high power laser, handling equipment and conveyance equipment that are configured to avoid exceeding the maximum bending radius of high power optical fibers used with the conveyance structures. There are also provided embodiments of the conveyance structures having channels, lines and passages for delivering materials such as fluids.

WO 2012/024285 A1

**Published:**

— with international search report (Art. 21(3))

— before the expiration of the time limit for amending the claims and to be republished in the event of receipt of amendments (Rule 48.2(h))

## SYSTEMS AND CONVEYANCE STRUCTURES FOR HIGH POWER LONG DISTANCE LASER TRANSMISSION

**[0001]** This application: (i) claims, under 35 U.S.C. §119(e)(1), the benefit of the filing date of August 17, 2010 of provisional application serial number 61/374,594; (ii) claims, under 35 U.S.C. §119(e)(1), the benefit of the filing date of August 31, 2010 of provisional application serial number 61/378,910; (iii) claims, under 35 U.S.C. §119(e)(1), the benefit of the filing date of February 24, 2011 of provisional application serial number 61/446,312; and, (iv) claims, under 35 U.S.C. §119(e)(1), the benefit of the filing date of February 7, 2011 of provisional application serial number 61/439,970, the entire disclosures of each of which are incorporated herein by reference.

**[0002]** This invention was made with Government support under Award DE-AR0000044 awarded by the Office of ARPA-E U.S. Department of Energy. The Government has certain rights in this invention.

### BACKGROUND OF THE INVENTION

#### Field of the Invention

**[0003]** The present inventions relate to the delivery of high power laser energy. More particularly, the present inventions relate to systems, methods and structures for conveying high power laser energy, alone or in conjunction with other items, such as, data, electricity, gases and liquids, to remote, difficult to access or hazardous locations, such as oil wells, boreholes in the earth, pipelines, underground mines, natural gas wells, geothermal wells, mining, subsea structures, or nuclear reactors. The high power laser energy and other items may be used at the delivered location for activities, such as, monitoring, cleaning, controlling, assembling, drilling, machining, powering equipment and cutting.

**[0004]** As used herein, unless specified otherwise “high power laser energy” means a laser beam having at least about 1 kW (kilowatt) of power. As used herein, unless specified otherwise “great distances” means at least about 500 m (meter). As used herein, unless specified otherwise, the term “substantial loss of power,” “substantial power loss” and similar such phrases, mean a loss of power of more than

about 3.0 dB/km (decibel/kilometer) for a selected wavelength. As used herein the term "substantial power transmission" means at least about 50% transmittance.

**[0005]** As used herein, unless specified otherwise, "optical connector", "fiber optics connector", "connector" and similar terms should be given their broadest possible meaning and include any component from which a laser beam is or can be propagated, any component into which a laser beam can be propagated, and any component that propagates, receives or both a laser beam in relation to, *e.g.*, free space, (which would include a vacuum, a gas, a liquid, a foam and other non-optical component materials), an optical component, a wave guide, a fiber, and combinations of the forgoing.

**[0006]** As used herein the term "pipeline" should be given its broadest possible meaning, and includes any structure that contains a channel having a length that is many orders of magnitude greater than its cross-sectional area and which is for, or capable of, transporting a material along at least a portion of the length of the channel. Pipelines may be many miles long and may be many hundreds of miles long. Pipelines may be located below the earth, above the earth, under water, within a structure, or combinations of these and other locations. Pipelines may be made from metal, steel, plastics, ceramics, composite materials, or other materials and compositions known to the pipeline arts and may have external and internal coatings, known to the pipeline arts. In general, pipelines may have internal diameters that range from about 2 to about 60 inches although larger and smaller diameters may be utilized. In general natural gas pipelines may have internal diameters ranging from about 2 to 60 inches and oil pipelines have internal diameters ranging from about 4 to 48 inches. Pipelines may be used to transmit numerous types of materials, in the form of a liquid, gas, fluidized solid, slurry or combinations thereof. Thus, for example pipelines may carry hydrocarbons; chemicals; oil; petroleum products; gasoline; ethanol; biofuels; water; drinking water; irrigation water; cooling water; water for hydroelectric power generation; water, or other fluids for geothermal power generation; natural gas; paints; slurries, such as mineral slurries, coal slurries, pulp slurries; and ore slurries; gases, such as nitrogen and hydrogen; cosmetics; pharmaceuticals; and food products, such as beer.

**[0007]** As used herein the term “earth” should be given its broadest possible meaning, and includes, the ground, all natural materials, such as rocks, and artificial materials, such as concrete, that are or may be found in the ground, including without limitation rock layer formations, such as, granite, basalt, sandstone, dolomite, sand, salt, limestone, rhyolite, quartzite and shale rock.

**[0008]** As used herein the term “borehole” should be given its broadest possible meaning and includes any opening that is created in a material, a work piece, a surface, the earth, a structure (*e.g.*, building, protected military installation, nuclear plant, offshore platform, or ship), or in a structure in the ground, (*e.g.*, foundation, roadway, airstrip, cave or subterranean structure) that is substantially longer than it is wide, such as a well, a well bore, a well hole, a micro hole, slimhole and other terms commonly used or known in the arts to define these types of narrow long passages. Wells would further include exploratory, production, abandoned, reentered, reworked, and injection wells. Although boreholes are generally oriented substantially vertically, they may also be oriented on an angle from vertical, to and including horizontal. Thus, using a vertical line, based upon a level as a reference point, a borehole can have orientations ranging from 0° *i.e.*, vertical, to 90°, *i.e.*, horizontal and greater than 90° *e.g.*, such as a heel and toe, and combinations of these such as for example “U” and “Y” shapes. Boreholes may further have segments or sections that have different orientations, they may have straight sections and arcuate sections and combinations thereof; and for example may be of the shapes commonly found when directional drilling is employed. Thus, as used herein unless expressly provided otherwise, the “bottom” of a borehole, the “bottom surface” of the borehole and similar terms refer to the end of the borehole, *i.e.*, that portion of the borehole furthest along the path of the borehole from the borehole’s opening, the surface of the earth, or the borehole’s beginning. The terms “side” and “wall” of a borehole should to be given their broadest possible meaning and include the longitudinal surfaces of the borehole, whether or not casing or a liner is present, as such, these terms would include the sides of an open borehole or the sides of the casing that has been positioned within a borehole. Boreholes may be made up of a single passage, multiple passages, connected passages and combinations thereof, in a situation where multiple boreholes are connected or interconnected each borehole

would have a borehole bottom. Boreholes may be formed in the sea floor, under bodies of water, on land, in ice formations, or in other locations and settings.

**[0009]** Boreholes are generally formed and advanced by using mechanical drilling equipment having a rotating drilling tool, *e.g.*, a bit. For example and in general, when creating a borehole in the earth, a drilling bit is extending to and into the earth and rotated to create a hole in the earth. In general, to perform the drilling operation the bit must be forced against the material to be removed with a sufficient force to exceed the shear strength, compressive strength or combinations thereof, of that material. Thus, in conventional drilling activity mechanical forces exceeding these strengths of the rock or earth must be applied. The material that is cut from the earth is generally known as cuttings, *e.g.*, waste, which may be chips of rock, dust, rock fibers and other types of materials and structures that may be created by the bit's interactions with the earth. These cuttings are typically removed from the borehole by the use of fluids, which fluids can be liquids, foams or gases, or other materials known to the art.

**[0010]** As used herein the term "advancing" a borehole should be given its broadest possible meaning and includes increasing the length of the borehole. Thus, by advancing a borehole, provided the orientation is less than 90° the depth of the borehole may also be increased. The true vertical depth ("TVD") of a borehole is the distance from the top or surface of the borehole to the depth at which the bottom of the borehole is located, measured along a straight vertical line. The measured depth ("MD") of a borehole is the distance as measured along the actual path of the borehole from the top or surface to the bottom. As used herein unless specified otherwise the term depth of a borehole will refer to MD. In general, a point of reference may be used for the top of the borehole, such as the rotary table, drill floor, well head or initial opening or surface of the structure in which the borehole is placed.

**[0011]** As used herein the terms "ream", "reaming", a borehole, or similar such terms, should be given their broadest possible meaning and includes any activity performed on the sides of a borehole, such as, *e.g.*, smoothing, increasing the diameter of the borehole, removing materials from the sides of the borehole, such as *e.g.*, waxes or filter cakes, and under-reaming.

**[0012]** As used herein the terms "drill bit", "bit", "drilling bit" or similar such terms, should be given their broadest possible meaning and include all tools designed or intended to create a borehole in an object, a material, a work piece, a surface, the earth or a structure including structures within the earth, and would include bits used in the oil, gas and geothermal arts, such as fixed cutter and roller cone bits, as well as, other types of bits, such as, rotary shoe, drag-type, fishtail, adamantine, single and multi-toothed, cone, reaming cone, reaming, self-cleaning, disc, three cone, rolling cutter, crossroller, jet, core, impreg and hammer bits, and combinations and variations of the these.

**[0013]** In both roller cone, fixed bits, and other types of mechanical drilling the state of the art, and the teachings and direction of the art, provide that to advance a borehole great force should be used to push the bit against the bottom of the borehole as the bit is rotated. This force is referred to as weight-on-bit ("WOB"). Typically, tens of thousands of pounds WOB are used to advance a borehole using a mechanical drilling process.

**[0014]** Mechanical bits cut rock by applying crushing (compressive) and/or shear stresses created by rotating a cutting surface against the rock and placing a large amount of WOB. In the case of a PDC bit this action is primarily by shear stresses and in the case of roller cone bits this action is primarily by crushing (compression) and shearing stresses. For example, the WOB applied to an 8 3/4" PDC bit may be up to 15,000 lbs, and the WOB applied to an 8 3/4" roller cone bit may be up to 60,000 lbs. When mechanical bits are used for drilling hard and ultra-hard rock excessive WOB, rapid bit wear, and long tripping times result in an effective drilling rate that is essentially economically unviable. The effective drilling rate is based upon the total time necessary to complete the borehole and, for example, would include time spent tripping in and out of the borehole, as well as, the time for repairing or replacing damaged and worn bits.

**[0015]** As used herein the term "drill pipe" is to be given its broadest possible meaning and includes all forms of pipe used for drilling activities; and refers to a single section or piece of pipe. As used herein the terms "stand of drill pipe," "drill pipe stand," "stand of pipe," "stand" and similar type terms should be given their broadest possible

meaning and include two, three or four sections of drill pipe that have been connected, e.g., joined together, typically by joints having threaded connections. As used herein the terms "drill string," "string," "string of drill pipe," "string of pipe" and similar type terms should be given their broadest definition and would include a stand or stands joined together for the purpose of being employed in a borehole. Thus, a drill string could include many stands and many hundreds of sections of drill pipe.

**[0016]** As used herein the term "tubular" is to be given its broadest possible meaning and includes drill pipe, casing, riser, coiled tube, composite tube, vacuum insulated tubing ("VIT), production tubing and any similar structures having at least one channel therein that are, or could be used, in the drilling industry. As used herein the term "joint" is to be given its broadest possible meaning and includes all types of devices, systems, methods, structures and components used to connect tubulars together, such as for example, threaded pipe joints and bolted flanges. For drill pipe joints, the joint section typically has a thicker wall than the rest of the drill pipe. As used herein the thickness of the wall of tubular is the thickness of the material between the internal diameter of the tubular and the external diameter of the tubular.

**[0017]** As used herein, unless specified otherwise the terms "blowout preventer," "BOP," and "BOP stack" should be given their broadest possible meaning, and include: (i) devices positioned at or near the borehole surface, e.g., the surface of the earth including dry land or the seafloor, which are used to contain or manage pressures or flows associated with a borehole; (ii) devices for containing or managing pressures or flows in a borehole that are associated with a subsea riser or a connector; (iii) devices having any number and combination of gates, valves or elastomeric packers for controlling or managing borehole pressures or flows; (iv) a subsea BOP stack, which stack could contain, for example, ram shears, pipe rams, blind rams and annular preventers; and, (v) other such similar combinations and assemblies of flow and pressure management devices to control borehole pressures, flows or both and, in particular, to control or manage emergency flow or pressure situations.

**[0018]** As used herein, unless specified otherwise "offshore" and "offshore drilling activities" and similar such terms are used in their broadest sense and would include drilling activities on, or in, any body of water, whether fresh or salt water,



whether manmade or naturally occurring, such as for example rivers, lakes, canals, inland seas, oceans, seas, bays and gulfs, such as the Gulf of Mexico. As used herein, unless specified otherwise the term "offshore drilling rig" is to be given its broadest possible meaning and would include fixed towers, tenders, platforms, barges, jack-ups, floating platforms, drill ships, dynamically positioned drill ships, semi-submersibles and dynamically positioned semi-submersibles. As used herein, unless specified otherwise the term "seafloor" is to be given its broadest possible meaning and would include any surface of the earth that lies under, or is at the bottom of, any body of water, whether fresh or salt water, whether manmade or naturally occurring.

**[0019]** As used herein, unless specified otherwise the term "fixed platform," would include any structure that has at least a portion of its weight supported by the seafloor. Fixed platforms would include structures such as: free-standing caissons, well-protector jackets, pylons, braced caissons, piled-jackets, skirted piled-jackets, compliant towers, gravity structures, gravity based structures, skirted gravity structures, concrete gravity structures, concrete deep water structures and other combinations and variations of these. Fixed platforms extend from at or below the seafloor to and above the surface of the body of water, e.g., sea level. Deck structures are positioned above the surface of the body of water a top of vertical support members that extend down in to the water to the seafloor. Fixed platforms may have a single vertical support, or multiple vertical supports, e.g., pylons, legs, etc., such as a three, four, or more support members, which may be made from steel, such as large hollow tubular structures, concrete, such as concrete reinforced with metal such as rebar, and combinations of these. These vertical support members are joined together by horizontal and other support members. In a piled-jacket platform the jacket is a derrick-like structure having hollow essentially vertical members near its bottom. Piles extend out from these hollow bottom members into the seabed to anchor the platform to the seabed.

**[0020]** As used herein the terms "decommissioning," "plugging" and "abandoning" and similar such terms should be given their broadest possible meanings and would include activities relating to the cutting and removal of casing and other tubulars from a well (above the surface of the earth, below the surface of the earth and both), modification or removal of structures, apparatus, and equipment from a site to

return the site to a prescribed condition, the modification or removal of structures, apparatus, and equipment that would render such items in a prescribe inoperable condition, the modification or removal of structures, apparatus, and equipment to meet environmental, regulatory, or safety considerations present at the end of such items useful, economical or intended life cycle. Such activities would include for example the removal of onshore, e.g., land based, structures above the earth, below the earth and combinations of these, such as e.g., the removal of tubulars from within a well in preparation for plugging. The removal of offshore structures above the surface of a body of water, below the surface, and below the seafloor and combinations of these, such as fixed drilling platforms, the removal of conductors, the removal of tubulars from within a well in preparation for plugging, the removal of structures within the earth, such as a section of a conductor that is located below the seafloor and combinations of these.

**[0021]** As used herein the terms "workover," "completion" and "workover and completion" and similar such terms should be given their broadest possible meanings and would include activities that place at or near the completion of drilling a well, activities that take place at or the near the commencement of production from the well, activities that take place on the well when the well is producing or operating well, activities that take place to reopen or reenter an abandoned or plugged well or branch of a well, and would also include for example, perforating, cementing, acidizing, fracturing, pressure testing, the removal of well debris, removal of plugs, insertion or replacement of production tubing, forming windows in casing to drill or complete lateral or branch wellbores, cutting and milling operations in general, insertion of screens, stimulating, cleaning, testing, analyzing and other such activities. These terms would further include applying heat, directed energy, preferably in the form of a high power laser beam to heat, melt, soften, activate, vaporize, disengage, desiccate and combinations and variations of these, materials in a well, or other structure, to remove, assist in their removal, cleanout, condition and combinations and variation of these, such materials.

## SUMMARY

**[0022]** There has been a long standing need for a system that can deliver high power directed energy over great distances to small and/or difficult to access locations, positions or environments for use in activities such as monitoring, cleaning, controlling, assembling, drilling, machining, powering equipment, flow assurance and cutting. Such need is present in the nuclear industry, the chemical industry, the subsea exploration, salvage and construction industry, the pipeline industry, the military, and the oil, natural gas and geothermal industries to name just a few. The present inventions, among other things, solve these and other needs by providing the articles of manufacture, devices and processes taught herein.

**[0023]** Thus, there is provided herein a a mobile high power laser system including: a laser cabin, the laser cabin housing a high power laser system having the capability to general a laser beam having at least about 10 kW of power and a wavelength in the range of about 800 nm to about 2100 nm; a conveyance structure having a length of at least about 3,000 feet; the conveyance structure including: a high power optical fiber having a core diameter of at least about 500  $\mu\text{m}$  and a length of at least about 3,000 ft, a first support structure having a length of at least about 3,000 feet, a second support structure having a length of at least about 3,000 feet, a data or control line having a length of at least about 3,000 feet, and a passage defined by the first or second support structure, the passage having a length of at least about 3,000 feet; and a means for handling the conveyance structure. Still further there is provided this laser system: where the means for handling may have an injector; where the means for handling may have a spool and an optical slip ring; may include a second passage and where the line provides electric power; and, including an optical block.

**[0024]** Yet further this is provided a mobile high power laser system including: a laser cabin, the laser cabin housing a high power laser having the capability to general a laser beam having at least about 10 kW of power; a conveyance structure having a length of at least about 4,000 feet; the conveyance structure including: a high power optical fiber having a core diameter of at least about 300  $\mu\text{m}$  and a length of at least about 4,000 feet, an outer support structure having a length of at least about 4,000 feet, an inner support structure having a length of at least about 4,000 feet, a data or

control line having a length of at least about 4,000 feet, and a passage defined by the inner or the outer support structure, the passage having a length of at least about 4,000 feet; and a means for handling the conveyance structure. This mobile laser system may also lengths of the optical fiber, the outer support structure, the inner support structure, the line, and the passage of at least about 5,000 feet, and of at least about 10,000 feet, and may also include where the means for handling has an injector, where the means for handling has a spool and an optical slip ring, where a second passage is included and wherein the line provides electric power, and may also include an optical block.

**[0025]** Moreover, there is provided a mobile high power laser system including: a base; a means for providing a high power laser beam having at least 5 kW of power; a means for containing a handling apparatus; an operator station; and, a means for providing electrical power. Additionally, this high power system may have the base including a truck chassis, the means for providing the high power laser beam having a mobile laser room and wherein the mobile laser room is mounted to the truck chassis; having the means for containing the handling apparatus having a handling apparatus cabin or a handling apparatus bay and having a handling apparatus including at least about 4,000 feet of a high power conveyance structure; and wherein the operator station may be controllably associated with the mobile laser room and the handling apparatus. This system may also have the base having a trailer; wherein the means for providing the high power laser beam has a mobile laser room; wherein the means for containing the handling apparatus has a handling apparatus cabin or a handling apparatus bay, and has a handling apparatus including at least about 4,000 feet of a high power conveyance structure and is mounted to the trailer; and wherein the operator booth may be controllably associated with the mobile laser room and the handling apparatus.

**[0026]** Yet further, there is provided a mobile high power laser system including: a laser housing; a handling apparatus; a high power laser capable of generating at least a 10 kW laser beam within the laser housing; a conveyance structure including a high power optical fiber, a passage, a line and a support structure, wherein the high power optical fiber having a core diameter of at least about 300  $\mu\text{m}$  and a minimum bend radius; and, an optical block having a radius of curvature, wherein

the optical block radius of curvature is greater than, equal to, or within 5% less than the radius of curvature of the high power optical fiber.

**[0027]** There are also provided mobile high power laser systems including at least 5,000 feet of conveyance structure and where the core diameter may be at least about 450  $\mu\text{m}$ , where the high power laser is capable of generating a laser beam of at least 20 kW, where the laser housing and the handling apparatus are associated with a platform, where the laser housing is associated with a first mobile base and the handling apparatus is associated with a second mobile base and combinations of these.

**[0028]** Additionally there is provided a mobile high power laser system including: a base; the base having a laser housing, an operator housing and a handling apparatus; a chiller, a storage tank, and a laser capable of generating at least a 10 kW laser beam being associated with the laser housing; a conveyance structure including a high power optical fiber, a passage, a line and a support structure, wherein the high power optical fiber has a minimum bend radius; and, an optical block having a radius of curvature, wherein the optical block radius of curvature is greater than or substantially equal to the radius of curvature of the high power optical fiber.

**[0029]** Additionally, there are provided mobile high power laser systems where the conveyance structure is at least 5,000 feet, where the support structure of the conveyance structure defines an outer surface for the conveyance structure, where the high power optical fiber is at least practically contained within the support structure, where the high power optical fiber forms at least a portion of the outer surface for the conveyance structure, where the high power optical fiber and the line are inside of the support structure, where the wavelength of the laser beam is from about 800 nm to about 2100 nm, where the wavelength of the laser beam is from about 1060 nm to about 1800 nm, where the wavelength of the laser beam is from about 1800 nm to about 2100 nm, including a second high power optical fiber and a passage, including a plurality of lines, a plurality of high power optical fibers, and a plurality of support structures, where the optical block is associated with the base, where the base is a trailer, where the base is a truck chassis, where the base is a skid, where a shipping container defines at least the laser housing, where the chiller is located within the laser housing and includes: air intake and exhaust means that may be associated with the

chiller and provided in the laser housing, at least one storage tank comprises a heating element and combinations of these.

**[0030]** There are still further provided herein mobile high power laser system having where the conveyance structure is at least 5,000 feet, the optical fiber comprises a core having a core diameter of at least about 300  $\mu\text{m}$  and the high power laser system comprises a means for suppressing a non-linear effect.

**[0031]** Yet additionally, there are provided mobile high power laser systems including a plurality of lines, a plurality of high power optical fibers, and a plurality of support structures.

**[0032]** Further still there is provided a high power laser system including: a mobile platform; a laser housing associated with the mobile platform; a chiller, and a laser capable of generating at least a 10 kW laser beam; at least 1,000 feet of a conveyance structure including a high power optical fiber and a protective structure, wherein the high power optical fiber has a core having a diameter of at least about 300  $\mu\text{m}$  and a minimum bend radius; and, an optical block having a radius of curvature, wherein the optical block radius of curvature is greater than about 3% less than the radius of curvature of the high power optical fiber.

**[0033]** Additionally, there are provided high power laser systems having a laser: that is capable of generating at least a 20 kW laser beam, capable of generating at least a 30 kW laser beam, capable of generating at least a 50 kW laser beam, where the laser has a first laser capable of providing at least a 5 kW laser beam and a second laser capable of providing at least a 5 kW laser, wherein the laser has a plurality of lasers each capable of generating a laser beam having a power so that the combined power of the plurality of laser beams is at least about 10 kW, at least a 20 kW laser beam, and at least about 50 kW.

**[0034]** Further, there is provided a high power laser system including: a mobile platform; a laser housing associated with the mobile platform; a laser system capable of generating at least a 10 kW laser beam; a conveyance structure including a high power optical fiber and a protective structure, wherein the high power optical fiber has a minimum bend radius; and, the conveyance structure associated with a handling apparatus for holding and deploying the conveyance structure, wherein the handling

apparatus is configured to maintain the radius of curvature for the optical fiber at a radius that is greater than, equal to, or within 5% less than the minimum bend radius. This laser system where the handling apparatus is configured to maintain the radius of curvature for the conveyance structure at a radius that is at least 1% greater than the minimum bend radius, that is at least 2% greater than the minimum bend radius, or that is at least 5% greater than the minimum bend radius.

**[0035]** Moreover there is provided a high power laser system including: a mobile platform; a laser housing associated with the mobile platform; a laser system capable of generating at least a 20 kW laser beam; a laser chiller; a conveyance structure including a high power optical fiber and a support structure, wherein the high power optical fiber has a core having a diameter of at least about 300  $\mu\text{m}$ , and a minimum bend radius; a means for suppressing Stimulated Brillouin Scattering; and, the conveyance structure associated with a handling apparatus for holding and deploying the conveyance structure, wherein the handling apparatus is configured to maintain the radius of curvature for the conveyance structure at a radius that is equal to or greater than the minimum bend radius.

**[0036]** Yet still further there is provided a high power laser system deployed at a well site, the system including: a high power laser system capable of generating at least a 10 kW laser beam; a chiller; a conveyance structure deployment device; an optical block; a conveyance structure having a distal end and a proximal end and including a high power optical fiber having a minimal bend radius; a lubricator; wherein the proximal end of the conveyance structure is optically associated with the high power laser and associated with the deployment device; wherein the conveyance structure is at least practically held by the deployment device and extends from the deployment device to the optical block and extends from the optical block to and into the lubricator, thereby defining a conveyance structure deployment path; wherein the lubricator is in communication with a well at the well site; and, the conveyance structure deployment path does not exceed the minimum bend radius for the optical fiber.

**[0037]** Additionally, there is provided a mobile high power laser system wherein the conveyance structure comprises: a data line, a passage, a support

structure and a protective structure and wherein the high power laser system comprises a means to suppress a non-linear effect.

**[0038]** Yet additionally there is provided a high power laser system deployed at a well site, the system including: a means for generating a high power laser beam having at least a 10 kW of power; a means for deploying a conveyance structure; a conveyance structure having a distal end and a proximal end and including a high power optical fiber having a minimal bend radius and having a core diameter of at least about 300  $\mu\text{m}$ ; a means for entering a well; wherein the proximal end of the conveyance structure is optically associated with the high power laser; wherein the conveyance structure is at least practically held by the means for deploying and extends to and into the means for entering a well, thereby defining a conveyance structure deployment path; wherein the means for entering the well is in communication with a well at the well site; and, the conveyance structure deployment path does not exceed the minimum bend radius for the optical fiber, is at least greater than 5% less than the minimum bend radius, or is greater than, equal to, or more than 5% less than the minimum bend radius.

**[0039]** Moreover, there is provided a laser work over and completion unit including: a base; a handling apparatus associated with the base; a means for receiving a laser beam having at least a 5 kW laser beam being associated with the handling apparatus; a conveyance structure including a means for transmitting a laser beam having at least 5 kW of power over at least 3,000 without substantial power loss; a passage, a line and a support structure, wherein the means for transmitting has a minimum bend radius; and, an optical block having a radius of curvature, wherein the optical block radius of curvature is greater than, equal to, or within 5% less than the radius of curvature of the means for transmitting.

**[0040]** Still further there is provided a laser workover and completion system deployed at a well site, the system including: a conveyance structure deployment device; an optical block; a conveyance structure having a distal end and a proximal end and including a high power optical fiber having a proximal end and a distal end, and having a minimal bend radius, the proximal end of the high power optical fiber being capable of receiving a high power laser beam and the high power optical fiber being capable of transmitting a high power laser beam without substantial power loss; a



lubricator; wherein the proximal end of the conveyance structure is associated with the deployment device; wherein the conveyance structure is at least practically held by the deployment device and extends from the deployment device to the optical block and extends from the optical block to and into the lubricator, thereby defining a conveyance structure deployment path; wherein the lubricator is in communication with a well at the well site; and, the conveyance structure deployment path does not exceed the minimum bend radius for the optical fiber.

**[0041]** Further yet, there is provided a laser workover and completion system deployed at a well site, the system including: a conveyance structure deployment device; an optical block; a conveyance structure having a distal end and a proximal end and including a high power optical fiber having a minimal bend radius; a means for entering a well; wherein the proximal end of the conveyance structure is optically associated with the high power laser and associated with the deployment device; wherein the conveyance structure is at least practically held by the deployment device and extends from the deployment device to the optical block and extends from the optical block to and into the means for entering a well, thereby defining a conveyance structure deployment path; wherein the means for entering the well is in communication with a well at the well site; and, the conveyance structure deployment path does is greater than, equal to, or within 5% less than the minimum bend radius for the optical fiber.

**[0042]** Moreover there is provided a high power laser conveyance structure including: a first layer including a plurality of wound armor wires; a second layer including a plurality of wound armor wires, wherein the second layer is positioned inside of the first layer; the second layer forming a cavity; the cavity containing a high power optical fiber; the high power optical fiber including a core and a cladding; the high power optical fiber being capable of reducing a non-linear effect when a high power laser beam is propagated through the optical fiber; and, the conveyance structure being at least 2,000 feet long.

**[0043]** Still further there is provided a high power laser conveyance structure including: a support structure; a line associated within the support structure; a high power optical fiber associated with the support structure; a passage associated with the

support structure for transporting a fluid; and, the high power optical fiber being capable of reducing a non-linear effect when a high power laser beam is propagated through the optical fiber over distances greater than 2,000 feet.

**[0044]** Yet still further there is provided a high power laser system including: a mobile platform; a laser housing associated with the mobile platform; a laser system capable of generating at least a 10 kW laser beam; a conveyance structure including a high power optical fiber and a protective structure, wherein the high power optical fiber has a minimum bend radius; and, the conveyance structure associated with a handling apparatus for holding and deploying the conveyance structure, wherein the handling apparatus is configured to maintain the radius of curvature for the optical fiber at a radius that is more than about 5% less than the minimum bend radius.

#### BRIEF DESCRIPTION OF THE DRAWINGS

**[0045]** FIG. 1A is a transverse cross sectional view, not necessarily to scale, showing the structure of an optical fiber of the present invention.

**[0046]** FIG. 1B is a longitudinal cross sectional view of the optical fiber of FIG. 1A.

**[0047]** FIG. 2 is a spectrum of laser energy transmitted by the present invention showing the absence of SRS phenomena.

**[0048]** FIG. 3 is a schematic view of a mobile laser system of the present invention.

**[0049]** FIG. 4 is a schematic diagram for a configuration of lasers of the present invention.

**[0050]** FIG. 5 is a schematic diagram for a configuration of laser of the present invention.

**[0051]** FIG. 6 is a perspective cutaway of a spool and optical rotatable coupler of the present invention.

**[0052]** FIG. 7 is a schematic diagram of a laser fiber amplifier of the present invention.

**[0053]** FIG. 8 is a cross sectional view of a spool of the present invention.

**[0054]** FIG. 9A and 9B are views of a creel of the present invention.

**[0055]** FIG. 10 is a schematic view of an embodiment of a handling apparatus of the present invention.

**[0056]** FIG. 11 is a schematic view of an embodiment of a handling apparatus of the present invention.

**[0057]** FIG. 12A to 12C are perspective views and a schematic cross sectional view, respectively, of an embodiment of a handling apparatus of the present invention.

**[0058]** FIG. 13 is a schematic view of a mobile laser system and control system of the present invention.

**[0059]** FIGS. 14, 15, 16, 17, 18, 19, 20A and 20B, 21, 22, 23, 24, 25, 26, 33 and 34 are schematic views of conveyance structures of the present invention.

**[0060]** FIG. 27A is a perspective view of a mobile high power laser system of the present invention.

**[0061]** FIG. 27B is a plan schematic view of the components of a section of the system of FIG. 27A.

**[0062]** FIG. 27C is longitudinal cross sectional view of the system of FIG. 27A.

**[0063]** FIG. 27D is a schematic view of the system of FIG. 27A deployed at a well site.

**[0064]** FIG. 28 is a schematic view of a mobile high power laser system having a bay for holding a conveyance structure of the present invention.

**[0065]** FIG. 29 is a perspective view of a mobile conveyance system of the present invention.

**[0066]** FIG. 30 is a perspective view of a mobile conveyance system of the present invention.

**[0067]** FIG. 31 is a perspective schematic view of a mobile high power laser system of the present invention.

**[0068]** FIG. 32A is a plan schematic view of a mobile high power laser system of the present invention.

**[0069]** FIG. 32B is a side view of the system of FIG. 32A.

**[0070]** FIG. 32C is a rear view of the system of FIG. 32A.

## DESCRIPTION OF THE PREFERRED EMBODIMENTS

**[0071]** The present inventions relate to the delivery of high power laser energy and particularly to systems, methods and structures for conveying high power laser energy, alone or in conjunction with other items, such as, data, electricity, gases and liquids, for use with tools, equipment or in activities such as monitoring, drilling, cleaning, controlling, assembling, machining, powering equipment and cutting.

**[0072]** Thus, and in general, there are provided high power laser systems, which may include, conveyance structures for use in delivering high power laser energy over great distances and to work areas where the high power laser energy may be utilized. Preferably, the system may include one or more high power lasers, which are capable of providing: one high power laser beam, a single combined high power laser beam, multiple high power laser beams, which may or may not be combined at various point or locations in the system, or combinations and variations of these.

**[0073]** A single high power laser may be utilized in the system, or the system may have two or three high power lasers, or more. High power solid-state lasers, specifically semiconductor lasers and fiber lasers are preferred, because of their short start up time and essentially instant-on capabilities. The high power lasers for example may be fiber lasers or semiconductor lasers having 10 kW, 20 kW, 50 kW or more power and, which emit laser beams with wavelengths in the range from about 455 nm (nanometers) to about 2100 nm, preferably in the range about 800 nm to about 1600 nm, about 1060 nm to 1080 nm, 1530 nm to 1600 nm, 1800 nm to 2100 nm, and more preferably about 1064 nm, about 1070-1080 nm, about 1360 nm, about 1455 nm, 1490 nm, or about 1550 nm, or about 1900 nm (wavelengths in the range of 1900 nm may be provided by Thulium lasers).

**[0074]** For example a preferred type of fiber laser would be one that includes 20 modules or more. The gain bandwidth of a fiber laser is on the order of 20 nm, the linewidth of the free oscillator is 3 nm, Full Width Half Maximum (FWHM) and may range from 3 nm to 5 nm (although higher linewidths including 10 nm are envisioned and contemplated). Each module's wavelength is slightly different. The modules further each create a multi-mode beam. Thus, the cumulative effect of combining the beams from the modules is to maintain the Raman gain and the Brillouin gain at a lower

value corresponding to the wavelengths and linewidths of the individual modules, and thus, consequently reducing the SBS and SRS phenomenon in a fiber when the combined beams are transmitted through the fiber. An example of this general type of fiber laser is the IPG YLR-20000. The detailed properties of which are disclosed in US patent application Publication Number 2010/0044106.

**[0075]** In some embodiments, a fiber laser emitted light at wavelengths comprised of 1060 nm to 1080 nm, 1530 nm to 1600 nm, 1800 nm to 2100 nm, diode lasers from 400 nm to 1600 nm, CO<sub>2</sub> Laser at 10,600 nm (however, CO<sub>2</sub> laser do not couple into conventional fused silica optical fibers and thus a solid fiber capable of transmitting these wavelengths, or hollow light pipe or later developed optical means may be utilized to transmit this laser beam) , or Nd:YAG Laser emitting at 1064 nm can couple to the optical fibers. In some embodiments, the fiber can have a low water content. Preferably, the water content of the fiber should be as low as is possible.

**[0076]** Examples of preferred lasers, and in particular solid-state lasers, such as fibers lasers, are set forth in US Patent Application Publication Numbers 2010/0044106, 2010/0044105 and 2010/0215326 and in pending US Patent Application Serial Number 12/840,978, the entire disclosures of each of which are incorporated herein by reference. Further diode lasers, and for example, such lasers having a wavelength of from about 0.9 microns to 2 microns may be utilized.

**[0077]** In general, the system may also include one or more mobile laser structures, which could be, for example: an integrated laser wireline truck; a laser coiled tubing rig; a laser power spool and transmission cable; an integrated laser workover and completion unit; or other mobile or movable structures, such as integrated wheeled structures, trailers, semi-trailer, skids, shipping containers, rail cars or carriages, or similar equipment. Although a fixed laser structure may be employed, for example at a sight where the laser may be used for a longer term period, such as the decommissioning of a large facility. The mobile laser structures houses, or has a laser cabin that houses, the high power laser(s), and may further be specifically constructed to protect the laser from specifically anticipated environment conditions, such as desert conditions, off-shore conditions, arctic conditions, and other environmental conditions that may be present throughout the world, or it may be constructed to protect the laser

against the general and varied types of weather and environmental conditions that are encountered at oilfield sites throughout the world. The mobile laser structure may also have the support systems for the operation of the laser, such as a chiller, electric generators, beam switches, beam combiners, controllers, computers and other types of laser support, control or monitoring systems.

**[0078]** The mobile laser structure may also have, integral with, as a part of, as a separate mobile structure, or as a combination or variations of these, a high power laser conveyance structure and a handling apparatus for that structure. The handling apparatus may include, or be, a spool, a creel, reverse loop structures that do not twist the fiber, an optical slip ring, a figure-eight wrapping structure, and other structures and equipment for the handling of long tubing, cables, wires or fibers. The handling apparatus should be selected, constructed or configured to avoid, minimize or manage, transmission losses that may occur from macro-bending, micro-bending, strain or other physical, optical or opto-physical phenomena that may occur when a high power optical fiber is wound and unwound or otherwise paid out and retrieved. Thus, for example, it is preferable to avoid placing the fiber in a tighter, *i.e.*, smaller, bend radius, than the fiber manufacture's specified minimum bend radius. More preferably, the fiber should be configured and deployed to avoid having any radius of curvature that is within 1% of the minimum bend radius to provide a margin of error during operations. In general the minimum bend radius is the minimum radius of curvature to avoid a predetermined stress level for a particular fiber. Thus, it is preferred that the radii of curvature in the system be equal to or greater than the minimum bend radius, however, they may be 1% tighter, 2% tighter and about 5% tighter, provided that losses and stress induced detrimental effects do not substantially adversely effect the desired performance of the system in an intended application. Moreover, techniques, methods and configurations to avoid, minimize, or manage such losses are provided in US Patent Application, Serial Number 12/840,978 filed July 21, 2010, the entire disclosure of which is incorporated herein by reference.

**[0079]** The handling apparatus may also include a drive, power or rotating mechanism for paying out or retrieving the conveyance structure. This mechanism may be integral with the mobile laser structure and configured to receive and handle different

conveyance structures; for example, a laser wire line truck, having a bay to receive different sizes of spools, spools having different conveyance structures, or both. The drive, power or rotating mechanism may be integral with the mobile laser structure. And, this mechanism may be operably associated with the mobile laser structure in other manners.

**[0080]** Thus, the conveyance structure may be: a single high power optical fiber; it may be a single high power optical fiber that has shielding; it may be a single high power optical fiber that has multiple layers of shielding; it may have two, three or more high power optical fibers that are surrounded by a single protective layer, and each fiber may additionally have its own protective layer; it may contain or have associated with the fiber a support structure which may be integral with or releasable or fixedly attached to optical fiber (e.g., a shielded optical fiber is clipped to the exterior of a metal cable and lowered by the cable into a borehole); it may contain other conduits such as a conduit to carry materials to assist a laser cutter, for example gas, air, nitrogen, oxygen, inert gases; it may have other optical or metal fiber for the transmission of data and control information and signals; it may be any of the combinations and variations thereof.

**[0081]** The conveyance structure transmits high power laser energy from the laser to a location where high power laser energy is to be utilized or a high power laser activity is to be performed by, for example, a high power laser tool. The conveyance structure may, and preferably in some applications does, also serve as a conveyance device for the high power laser tool. The conveyance structure's design or configuration may range from a single optical fiber, to a simple to complex arrangement of fibers, support cables, shielding on other structures, depending upon such factors as the environmental conditions of use, performance requirements for the laser process, safety requirements, tool requirements both laser and non-laser support materials, tool function(s), power requirements, information and data gathering and transmitting requirements, control requirements, and combinations and variations of these.

**[0082]** Preferably, the conveyance structure may be coiled tubing, a tube within the coiled tubing, jointed drill pipe, jointed drill pipe having a pipe within a pipe, or may be any other type of line structure, that has a high power optical fiber associated

with it. As used herein the term "line structure" should be given its broadest meaning, unless specifically stated otherwise, and would include without limitation: wireline; coiled tubing; slick line; logging cable; cable structures used for completion, workover, drilling, seismic, sensing, and logging; cable structures used for subsea completion and other subsea activities; umbilicals; cables structures used for scale removal, wax removal, pipe cleaning, casing cleaning, cleaning of other tubulars; cables used for ROV control power and data transmission; lines structures made from steel, wire and composite materials, such as carbon fiber, wire and mesh; line structures used for monitoring and evaluating pipeline and boreholes; and would include without limitation such structures as Power & Data Composite Coiled Tubing (PDT-COIL) and structures such as Smart Pipe<sup>®</sup> and FLATpak<sup>®</sup>.

**[0083]** High powered conveyance structures and handling apparatus are disclosed in US Patent Application Publications 2010/0044106, 2010/0044105 and 2010/0215326 and in pending US Patent Application Serial Number 12/840,978, the entire disclosures of each of which are incorporated herein by reference.

**[0084]** High power long distance laser fibers, which are disclosed in detail in US Patent Application Publications 2010/0044106, 2010/0044105 and 2010/0215326 and in pending US Patent Application Serial Number 12/840,978, the entire disclosures of each of which are incorporated herein by reference, break the length-power-paradigm, and advance the art of high power laser delivery beyond this paradigm, by providing optical fibers and optical fiber cables (which terms are used interchangeably herein and should be given their broadest possible meanings, unless specified otherwise), which may be used as, in association with, or as a part of conveyance structures, that overcome these and other losses, brought about by nonlinear effects, macro-bending losses, micro-bending losses, stress, strain, and environmental factors and provides for the transmission of high power laser energy over great distances without substantial power loss.

**[0085]** An example of an optical fiber cable for transmitting high power laser energy over great distances is a cable having a length that is greater than about 0.5 km, greater than 2 km greater than about 3 km or greater than about 5 km; the cable is a layered structure comprising: a core; a cladding; a coating; a first protective layer; and,



a second protective layer, the cable is capable of transmitting laser energy having a power greater than or equal to about 1 kW, about 5 kW or about 10 kW, over the length of the cable with a power loss of less than about 2 dB/km and preferably less than about 1 dB/km and more preferably less than about 0.3 dB/km for a selected wavelength. This cable may also be capable of providing laser energy to a tool or surface; the laser energy having a spectrum, such that the laser energy at the delivery location is substantially free from SRS and SBS phenomena. Fiber cables may have lengths that are greater than 0.5 km, greater than about 1 km, greater than about 2 km, greater than about 3 km, or greater.

**[0086]** For example an optical fiber cable may be an optical fiber in a stainless steel metal tube, the tube having an outside diameter of about 1/8" ("inch"). The optical fiber having a core diameter of about 600  $\mu\text{m}$ , (microns), about 1000  $\mu\text{m}$ , and from about 600- 1000  $\mu\text{m}$ ,, a cladding thickness of about 50  $\mu\text{m}$ , (the thickness of a layer or coating is measured from the internal diameter or inner surface of the layer or coating to the outer diameter or outer surface of the layer or coating) and an acrylate coating thickness of about 100  $\mu\text{m}$ . The optical fiber may be within a TEFLON sleeve, that is within the stainless steel tube.

**[0087]** Single and multiple optical fiber cables and optical fibers may be utilized, or a single optical cable with multiple optical fibers may be utilized; thus for example an optical-fiber squid may be used, a beam combiner may be used, or other assemblies to combine multiple fibers into a single fiber may be used, as part of, or in conjunction with the laser systems and conveyance structures of the present invention. Although the use of single length of fiber, i.e., the length of fiber is made up of one fiber rather than a series of fibers coupled, spliced or otherwise optically affixed end to end, for the longer distance power transmission is preferred, the use of multiple lengths of fiber joined end to end may be utilized. Moreover, several lengths of the optical fiber cables, or several lengths of fiber core structures, or combinations of both, may be joined into a plurality of such structures, such as in a bundle of optical fiber cables, fiber core structures or combinations of both.

**[0088]** Large core optical fibers are utilized with the present systems and conveyance structures to provide for the transmission of high power laser energy over

great distances. Thus, configurations having a core diameter equal to or greater than 50 microns, equal to or greater than 75 microns and most preferably equal to or greater than 100 microns, or a plurality of optical fibers utilized. These optical fibers are protected by a protective structure(s), which may be independent of, integral with, provided by, or associated with, the conveyance structure.

**[0089]** For example, each optical fiber may have a carbon coating, a polymer, and may include TEFLON coating to cushion the optical fibers when rubbing against each other during deployment. Thus the optical fiber, or bundle of optical fibers, can have a diameter of from about greater than or equal to 150 microns to about 700 microns, 700 microns to about 1.5 mm, or greater than 1.5 mm.

**[0090]** The fibers may have a buffer or jacket coatings that may include preferably tefzel, or teflon, or another fluoropolymer or similar materials which have significant transmission at the desired wavelength, and substantial temperature capability for the selected application.

**[0091]** The carbon coating, is less preferred and finds applications in avoiding hydrogen effects and can range in thicknesses from 10 microns to >600 microns. The polymer or TEFLON coating can range in thickness from 10 microns to >600 microns and preferred types of such coating are acrylate, silicone, polyimide, PFA and others. The carbon coating can be adjacent the optical fiber, with the polymer or TEFLON coating being applied to it. Polymer, TEFLON, or other coatings are generally applied last to reduce binding of the optical fibers during deployment.

**[0092]** In some non-limiting embodiments, fiber optics may handle or transmit up to 10 kW per an optical fiber, up to 20 kW per an optical fiber, up to and greater than 50 kW per optical fiber. The optical fibers may transmit any desired wavelength or combination of wavelengths. In some embodiments, the range of wavelengths the optical fiber can transmit may preferably be between about 800 nm and 2100 nm. The optical fiber can be connected by a connector to another optical fiber to maintain the proper fixed distance between one optical fiber and neighboring optical fibers. The optical fibers may also be spliced end-to-end to increase the overall length of the uninterrupted optical fiber.

**[0093]** For example, optical fibers can be connected such that the beam spot from neighboring optical fibers when irradiating the material, such as a rock surface or casing to be cut are under 2" and non-overlapping to the particular optical fiber. The optical fiber may have any desired core size. In some embodiments, the core size may range from about 50 microns to 1 mm or greater and preferably is about 500 microns to about 1000 microns. The optical fiber can be single mode or multimode. If multimode, the numerical aperture of some embodiments may range from 0.1 to 0.6. A lower numerical aperture may be preferred for beam quality, and a higher numerical aperture may be easier to transmit higher powers with lower interface losses. In some embodiments, a fiber laser emitted light at wavelengths comprised of 1060 nm to 1080 nm, 1530 nm to 1600 nm, 1800 nm to 2100 nm, diode lasers from 800 nm to 2100 nm, or Nd:YAG Laser emitting at 1064 nm can couple to the optical fibers. In some embodiments, the optical fiber can have a low water content. The optical fiber can be jacketed, as a part of the conveyance structure or independently, such as with polyimide, acrylate, carbon polyamide, and carbon/dual acrylate or other material. If requiring high temperatures, a polyimide or a derivative material may be used to operate at temperatures over 300 C°. The optical fibers can be a hollow core photonic crystal or solid core photonic crystal. In some embodiments, using hollow core photonic crystal fibers at wavelengths of 1500 nm or higher may minimize absorption losses (however, at present these fibers have drawbacks in that higher power connectors are not readily available and thus would require the system to be optically associated without the use of connectors). Additionally, Zirconium Fluoride (ZrF<sub>4</sub>), Halide fibers, Fluoride glass fibers (e.g., Calcium Fluoride etc.) and active fibers may be utilized.

**[0094]** The use of the plurality of optical fibers can be bundled into a number of configurations to improve power density. The optical fibers forming a bundle may range from two at hundreds of watts to kilowatt powers in each optical fiber to millions at milliwatts or microwatts of power. In some embodiments, the plurality of optical fibers may be bundled and spliced at powers below 2.5 kW to step down the power. Power can be spliced to increase the power densities through a bundle, such as preferably up to 10 kW, more preferably up to 20 kW, and even more preferably up to or greater than

50 kW. The step down and increase of power allows the beam spot to increase or decrease power density and beam spot sizes through the fiber optics. In most examples, splicing the power to increase total power output may be beneficial so that power delivered through optical fibers does not reach past the critical power thresholds for fiber optics.

**[0095]** Thus, by way of example there is provided the following configurations set forth in Table 1 herein.

**[0096] Table 1**

Diameter of bundle	Number of fibers in bundle
100 microns	1
200 microns – 1 mm	2 to 100
100 microns – 1 mm	1

**[0097]** A thin wire may also be packaged, for example in the ¼" stainless tubing, along with the optical fibers to test the optical fiber for continuity. Alternatively a metal coating of sufficient thickness is applied to allow the optical fiber continuity to be monitored. These approaches, however, become problematic as the optical fiber exceeds 1 km in length, and do not provide a practical method for testing and monitoring. Other examples of continuity monitoring, break detection and fiber monitoring systems and apparatus are provided in US Patent Application Serial Number 61/446,407, the entire disclosure of which is incorporated herein by reference.

**[0098]** The configurations in Table 1, as well as other configurations, can be of lengths equal to or greater than 1 m, equal to or greater than 1 km, equal to or greater than 2 km, equal to or greater than 3 km, equal to or greater than 4 km and equal to or greater than 5 km. These configurations can be used to transmit power levels from about 0.5 kW to about 10 kW, from greater than or equal to 1 kW, greater than or equal to 2 kW, greater than or equal to 5 kW, greater than or equal to 8 kW, greater than or equal to 10 kW and preferable at least about 20 kW.

**[0099]** In transmitting power over long distances, such as down a borehole or through a cable that is at least 1 km, there are in general three sources of power losses from non-linear effects in an optical fiber, Rayleigh Scattering, Raman Scattering and

Brillouin Scattering. The first, Rayleigh Scattering is the intrinsic losses of the optical fiber due to the impurities in the optical fiber. The second, Raman Scattering can result in Stimulated Raman Scattering in a Stokes or Anti-Stokes wave off of the vibrating molecules of the optical fiber. Raman Scattering occurs preferentially in the forward direction and results in a wavelength shift of up to +25 nm from the original wavelength of the source. The third mechanism, Brillouin Scattering, is the scattering of the forward propagating pump off of the acoustic waves in the optical fiber created by the high electric fields of the original source light (pump). This third mechanism is highly problematic and may create great difficulties in transmitting high powers over long distances. The Brillouin Scattering can give rise to Stimulated Brillouin Scattering (SBS) where the pump light is preferentially scattered backwards in the optical fiber with a frequency shift of approximately 1 to about 20 GHz from the original source frequency. This Stimulated Brillouin effect can be sufficiently strong to backscatter substantially all of the incident pump light if given the right conditions. Therefore it is desirable to suppress this non-linear phenomenon. There are essentially four primary variables that determine the threshold for SBS: the length of the gain medium (the optical fiber); the linewidth of the source laser; the natural Brillouin linewidth of the optical fiber the pump light is propagating in; and, the mode field diameter of the optical fiber. Under typical conditions and for typical optical fibers, the length of the optical fiber is inversely proportional to the power threshold, so the longer the optical fiber, the lower the threshold. The power threshold is defined as the power at which a high percentage of incident pump radiation will be scattered such that a positive feedback takes place whereby acoustic waves are generated by the scattering process. These acoustic waves then act as a grating to incite further SBS. Once the power threshold is passed, exponential growth of scattered light occurs and the ability to transmit higher power is greatly reduced. This exponential growth continues with an exponential reduction in power until such point whereby any additional power input will not be transmitted forward which point is defined herein as the maximum transmission power. Thus, the maximum transmission power is dependent upon the SBS threshold, but once reached, the maximum transmission power will not increase with increasing power input.

**[00100]** Thus, as provided herein, novel and unique means for suppressing nonlinear scattering phenomena, such as the SBS and Stimulated Raman Scattering phenomena, means for increasing power threshold, and means for increasing the maximum transmission power are set forth for use in transmitting high power laser energy over great distances for, among other things, the advancement of boreholes.

**[00101]** The mode field diameter needs to be as large as practical without causing undue attenuation of the propagating source laser. Large core single mode optical fibers are currently available with mode diameters up to 30 microns, however bending losses are typically high and propagation losses are higher than desired. Small core step index optical fibers, with mode field diameters of 50 microns are of interest because of the low intrinsic losses, the significantly reduced fluence, the decreased SBS gain, a non-polarization preserving design, and, a multi-mode propagation constant. All of these factors effectively increase the SBS power threshold. Consequently, a larger core optical fiber with low Raleigh Scattering losses is a solution for transmitting high powers over great distances, preferably where the mode field diameter is 50 microns or greater in diameter.

**[00102]** The next consideration is the natural Brillouin linewidth of the optical fiber. As the Brillouin linewidth increases, the scattering gain factor decreases. The Brillouin linewidth can be broadened by varying the temperature along the length of the optical fiber, modulating the strain on the optical fiber and inducing acoustic vibrations in the optical fiber. Varying the temperature along the optical fiber results in a change in the index of refraction of the optical fiber and the background ( $kT$ ) vibration of the atoms in the optical fiber effectively broadening the Brillouin spectrum. In down borehole application the temperature along the optical fiber will vary naturally as a result of the geothermal energy that the optical fiber will be exposed to at the depths, and ranges of depths, expressed herein. The net result will be a suppression of the SBS gain. Applying a thermal gradient along the length of the optical fiber could be a means to suppress SBS by increasing the Brillouin linewidth of the optical fiber. For example, such means could include using a thin film heating element or variable insulation along the length of the optical fiber to control the actual temperature at each point along the

optical fiber. Applied thermal gradients and temperature distributions can be, but are not limited to, linear, step-graded, and non-periodic functions along the length of the optical fiber.

**[00103]** Modulating the strain for the suppression of nonlinear scattering phenomena, on the optical fiber can be achieved, but those means are not limited to anchoring the optical fiber in its jacket in such a way that the optical fiber is strained. By stretching each segment between support elements selectively, then the Brillouin spectrum will either red shift or blue shift from the natural center frequency effectively broadening the spectrum and decreasing the gain. If the optical fiber is allowed to hang freely from a tensioner, then the strain will vary from the top of the hole to the bottom of the hole, effectively broadening the Brillouin gain spectrum and suppressing SBS. Means for applying strain to the optical fiber include, but are not limited to, twisting the optical fiber, stretching the optical fiber, applying external pressure to the optical fiber, and bending the optical fiber. Thus, for example, as discussed above, twisting the optical fiber can occur through the use of a creel. Moreover, twisting of the optical fiber may occur through use of downhole stabilizers designed to provide rotational movement. Stretching the optical fiber can be achieved, for example as described above, by using support elements along the length of the optical fiber. Downhole pressures may provide a pressure gradient along the length of the optical fiber thus inducing strain.

**[00104]** Acoustic modulation of the optical fiber can alter the Brillouin linewidth. By placing acoustic generators, such as piezo crystals along the length of the optical fiber and modulating them at a predetermined frequency, the Brillouin spectrum can be broadened, effectively decreasing the SBS gain. For example, crystals, speakers, mechanical vibrators, or any other mechanism for inducing acoustic vibrations into the optical fiber may be used to effectively suppress the SBS gain. Additionally, acoustic radiation can be created by the escape of compressed air through predefined holes, creating a whistle effect.

**[00105]** A spectral beam combination of laser sources may be used to suppress Stimulated Brillouin Scattering. Thus the spaced wavelength beams, the spacing as

described herein, can suppress the Stimulated Brillouin Scattering through the interference in the resulting acoustic waves, which will tend to broaden the Stimulated Brillouin Spectrum and thus resulting in lower Stimulated Brillouin Gain. Additionally, by utilizing multiple colors the total maximum transmission power can be increased by limiting SBS phenomena within each color. An example of such a laser system is illustrated in FIG. 4.

**[00106]** For example, FIG. 4 illustrates a spectral beam combination of lasers sources to enable high power transmission down a fiber by allocating a predetermined amount of power per color as limited by the Stimulated Brillouin Scattering (SBS) phenomena. Thus, there is provided in FIG. 4 a first laser source 401 having a first wavelength of "x", where x may preferably be less than 1 micron, but may also be 1 micron and larger. There is provided a second laser 402 having a second wavelength of  $x + \delta_1$  microns, where  $\delta_1$  is a predetermined shift in wavelength, which shift could be positive or negative. There is provided a third laser 403 having a third wavelength of  $x + \delta_1 + \delta_2$  microns and a fourth laser 404 having a wavelength of  $x + \delta_1 + \delta_2 + \delta_3$  microns. The laser beams are combined by a beam combiner 405 and transmitted by an optical fiber 406. The combined beam having a spectrum shown in 407.

**[00107]** The interaction of the source linewidth and the Brillouin linewidth in part defines the gain function. Varying the linewidth of the source can suppress the gain function and thus suppress nonlinear phenomena such as SBS. The source linewidth can be varied, for example, by FM modulation or closely spaced wavelength combined sources, an example of which is illustrated in FIG. 5. Thus, a fiber laser can be directly FM modulated by a number of means, one method is simply stretching the fiber with a piezo-electric element which induces an index change in the fiber medium, resulting in a change in the length of the cavity of the laser which produces a shift in the natural frequency of the fiber laser. This FM modulation scheme can achieve very broadband modulation of the fiber laser with relatively slow mechanical and electrical components. A more direct method for FM modulating these laser sources can be to pass the beam through a non-linear crystal such as Lithium Niobate, operating in a phase modulation mode, and modulate the phase at the desired frequency for suppressing the gain.



**[00108]** FIG 5. Illustrates a frequency modulated array of lasers. Thus, there is provided a master oscillator that can be frequency modulated, directly or indirectly, that is then used to injection-lock lasers or amplifiers to create a higher power composite beam than can be achieved by any individual laser. Thus, there are provided lasers 501, 502, 503, and 504, which have the same wavelength. The laser beams are combined by a beam combiner 505 and transmitted by an optical fiber 506. The lasers 501, 502, 503 and 504 are associated with a master oscillator 508 that is FM modulated. The combined beam having a spectrum shown in 507, where  $\delta$  is the frequency excursion of the FM modulation. Such lasers are disclosed in U.S. Patent 5,694,408, the disclosure of which is incorporated here in reference in its entirety.

**[00109]** Raman scattering can be suppressed by the inclusion of a wavelength-selective filter in the optical path. This filter can be a reflective, transmissive, or absorptive filter. Moreover, an optical fiber connector can include a Raman rejection filter. Additionally a Raman rejection filter could be integral to the optical fiber. These filters may be, but are not limited to, a bulk filter, such as a dichroic filter or a transmissive grating filter, such as a Bragg grating filter, or a reflective grating filter, such as a ruled grating. For any backward propagating Raman energy, as well as, a means to introduce pump energy to an active fiber amplifier integrated into the overall optical fiber path, is contemplated, which, by way of example, could include a method for integrating a rejection filter with a coupler to suppress Raman Radiation, which suppresses the Raman Gain. Further, Brillouin scattering can be suppressed by filtering as well. Faraday isolators, for example, could be integrated into the system. A Bragg Grating reflector tuned to the Brillouin Scattering frequency, with a single frequency laser source and with the laser locked to a predetermined wavelength could also be integrated into the coupler to suppress the Brillouin radiation.

**[00110]** To overcome power loss in the optical fiber as a function of distance, active amplification of the laser signal can be used. An active fiber amplifier can provide gain along the optical fiber to offset the losses in the optical fiber. For example, by combining active fiber sections with passive fiber sections, where sufficient pump light is provided to the active, i.e., amplified section, the losses in the passive section will be

offset. Thus, there is provided a means to integrate signal amplification into the system. In FIG. 7 there is illustrated an example of such a means having a first passive fiber section 700 with, for example, -1 dB loss, a pump source 701 optically associated with the fiber amplifier 702, which may be introduced into the outer clad, to provide for example, a +1 dB gain of the propagating signal power. The fiber amplifier 702 is optically connected to a coupler 703, which can be free spaced or fused, which is optically connected to a passive section 704. This configuration may be repeated numerous times, for varying lengths, power losses, and downhole conditions. Additionally, the fiber amplifier could act as the delivery optical fiber for the entirety of the transmission length. The pump source may be uphole, downhole, or combinations of uphole and downhole for various borehole configurations.

**[00111]** A further method is to use dense wavelength beam combination of multiple laser sources to create an effective linewidth that is many times the natural linewidth of the individual laser effectively suppressing the SBS gain. Here multiple lasers each operating at a predetermined wavelength and at a predetermined wavelength spacing are superimposed on each other, for example by a grating. The grating can be transmissive or reflective.

**[00112]** Mode field variation as a function of length, index of refraction as a function of length, core size variation as a function of length, the fusing of different types or specifications for fibers together, altering the gain spectrum of the fiber, altering the spectrum of the laser, the pulsing of the laser at shorter time durations than the time constant of the phonon propagation in the fiber, are methodologies, that may be utilized in in combination with each other, and in combination with, a lone, or in addition to, other methodologies provided in this specification to suppresses or reduce non-linear effects.

**[00113]** The optical fiber or fiber bundle can be: encased in a separate shield or protective layer; or incorporated in or associated with a conveyance structure; or both, to shield the optical fiber and to enable it to survive at high pressures and temperatures. The cable could be similar in construction to the submarine cables that are laid across the ocean floor and may be buoyant, or have neutral buoyancy, if the

borehole is filled with water. The cable may include one or many optical fibers in the cable, depending on the power handling capability of the optical fiber and the power required to achieve economic drilling rates. It being understood that in the field several km of optical fiber may have to be delivered down the borehole. The fiber cables may be made in varying lengths such that shorter lengths are used for shallower depths so higher power levels can be delivered and consequently higher drilling rates can be achieved. This method requires the optical fibers to be changed out when transitioning to depths beyond the length of the fiber cable. Alternatively a series of connectors could be employed if the connectors could be made with low enough loss to allow connecting and reconnecting the optical fiber(s) with minimal losses.

[00114] Thus, there is provided in Tables 2 and 3 herein power transmissions for exemplary optical cable configurations.

[00115] Table 2

Power in	Length of fiber(s)	Diameter of bundle	# of fibers in bundle	Power out
20 kW	5 km	500 microns	1	15 kW
20 kW	7 km	500 microns	1	13 kW
20 kW	5 km	650 micron	1	15 kW
20 kW	5 km	1mm	1	15 kW
20 kW	7 km	1.05mm	1	13 kW
20 kW	5 km	200 microns – 1mm	2 to 100	12 - 15 kW
20 kW	7 km	200 microns – 1mm	2 to 100	8 - 13 kW
20 kW	5 km	100 – 200 microns	1	10 kW
20 kW	7 km	100 – 200 microns	1	8 kW

[00116] Table 3 (with active amplification)

Power in	Length of fiber(s)	Diameter of bundle	# of fibers in bundle	Power out
20 kW	5 km	500 microns	1	20 kW
20 kW	7 km	500 microns	1	20 kW
20 kW	5 km	200 microns – 1mm	2 to 100	20 kW
20 kW	7 km	200 microns – 1mm	2 to 100	20 kW

20 kW	5 km	100 – 200 microns	1	20 kW
20 kW	7 km	100 – 200 microns	1	20 kW

**[00117]** The optical fibers may be placed inside of or associated with a conveyance structure such as a coiled tubing, line structure, or composite tubular structure for advancement into and removal from the borehole. In this manner the line structure or tubing would be the primary load bearing and support structure as the assembly is lowered into the well. It can readily be appreciated that in wells of great depth the tubing will be bearing a significant amount of weight because of its length. In configurations where the optical fiber is located inside of an open passage or channel in the tube, as opposed to being integral with, fixed to, or otherwise associated with the side wall of the tube, to protect and secure the optical fibers, including the optical fiber bundle contained in the, for example, ¼" or 1/8" or similar size stainless steel tubing, inside the coiled tubing stabilization devices may be desirable. Thus, at various intervals along the length of the tubing supports can be located inside the tubing that fix or hold the optical fiber in place relative to the tubing. These supports, however, should not interfere with, or otherwise obstruct, the flow of fluid, if fluid is being transmitted through the tubing. An example of a commercially available stabilization system is the ELECTROCOIL System. These support structures, as described above, may be used to provide strain to the optical fiber for the suppression of nonlinear phenomena.

**[00118]** The optical fibers may also be associated with the tubing by, for example, being run parallel to the tubing, and being affixed thereto, by being run parallel to the tubing and be slidably affixed thereto, or by being placed in a second tubing that is associated or not associated with the first tubing. In this way, it should be appreciated that various combinations of tubulars may be employed to optimize the delivery of laser energy, fluids, and other cabling and devices into the borehole. Moreover, the optical fiber may be segmented and employed with conventional strands of drilling pipe and thus be readily adapted for use with a conventional mechanical drilling rig outfitted with connectable tubular drill pipe, or it may be associated with the exterior of the drill pipe as the pipe is tripped into the well (and correspondingly disassociated from the pipe as it is tripped out of the well).

**[00119]** For example, and in general, there is provided in Figs. 1A and 1B an optical fiber cable having a core 1, a cladding 2, a coating 3, a first protective layer 4, and a second protective layer 5. Although shown in the figures as being concentric, it is understood that the components may be located off-center, off-center and on-center at different locations, and that the core, the core and cladding and the core, cladding and coating may be longer or shorter than the one or more of the protective layers.

**[00120]** The core 1 is preferably composed of fused silica having a water content of at most about 0.25 ppm or less. The core may be composed of other materials, such as those disclosed in US Patent Application Publication Numbers 2010/0044106, 2010/0044105 and 2010/0215326 and in pending US Patent Application Serial Number 12/840,978, the entire disclosures of each of which are incorporated herein by reference. Higher purity materials, and the highest purity material available, for use in the core are preferred. Thus, this higher purity material minimizes the scattering losses caused by defects and inclusions. The core is about 200 to about 700 microns in diameter, preferably from about 500 to about 600 microns in diameter and more preferably about 600 microns in diameter.

**[00121]** The cladding 2 is preferably composed of fluorine doped fused silica. The cladding may be composed of other materials such as fused silica doped with index-altering ions (germanium), as well as, those disclosed in US Patent Application Publication Numbers 2010/0044106, 2010/0044105 and 2010/0215326 and in pending US Patent Application Serial Number 12/840,978 the disclosures of each of which are incorporated herein by reference. The cladding thickness, depending upon the wavelength being used and the core diameter, is from about 50 microns to about 250 microns, preferably about 40 microns to about 70 microns and more preferably about 60 microns. As used herein with respect to a multi-layer structure, the term "thickness" means the distance between the layer's inner diameter and its outer diameter. The thickness of the cladding is dependent upon and relative to the core size and the intended wavelength. To determine the thickness of the cladding the following may be considered the wavelength, dopant levels, NA, bend sensitivity, the composition and thickness of the outer coating or additional claddings, and factors pertinent to end use considerations. Thus, by way of illustration in general fibers may fall within the following

for 1.1 micron wavelength the outer diameter of the cladding could be 1.1 x the outer diameter of core or greater; and, for a 1.5 micron wavelength the outer diameter of the cladding could be 1.5 x the outer diameter of the core or greater. Although a single cladding is illustrated, it is understood that multiple cladding may be utilized.

**[00122]** The coating 3 is preferably composed of a high temperature acrylate polymer, for higher temperatures a polyimide coating is desirable. The coating may be composed of other materials, such a metal, as well as those disclosed in US Patent Application Publication Numbers 2010/0044106, 2010/0044105 and 2010/0215326 and in pending US Patent Application Serial Number 12/840,978 the disclosures of each of which are incorporated herein by reference. The coating thickness is preferably from about 50 microns to about 250 microns, preferably about 40 microns to about 150 microns and more preferably about 90 microns. The coating thickness may even be thicker for extreme environments, conditions and special uses or it may be thinner for environments and uses that are less demanding. It can be tailored to protect against specific environmental and/or physical risks to the core and cladding that may be encountered and/or anticipated in a specific use for the cable.

**[00123]** The first protective layer 4 and the second protective layer 5 may be the same or they may be different, or they may be a single composite layer include different materials. Preferably the first and second protective layers are different materials.

**[00124]** The first protective layer may be thixotropic gel. This layer may be used to primarily protect the fiber from absorption loss from hydroxyl ions and vibration. Some gels set forth for example below, may be specifically designed or used to absorb hydroxyl ions, or prevent the migration of substances to cause their formation. The thixotropic gel protects the fiber from mechanical damage due to vibrations, as well as, provides support for the fiber when hanging vertically because its viscosity increases when it is static. A palladium additive is be added to the thixotropic gel to provide hydrogen scavenging. The hydrogen which diffuses into the fiber may be problematic for Germanium or similar ion doped cores. When using a pure fused sillca core, it is less of an effect and may be dramatically reduced. The first protective layer may be composed of other materials, such as, TEFLON, and those disclosed in US Patent

Application Publication Numbers 2010/0044106, 2010/0044105 and 2010/0215326 and in Pending US Patent Application Serial Number 12/840,978 the disclosures of which are incorporated herein by reference. The thickness of the first protective layer should be selected based upon the environment and conditions of use as well as the desired flexibility and/or stiffness of the cable and the design, dimensions and performance requirements for the conveyance structure that they may be incorporated into or associated with. Thus, the composition and thickness of the first protective layer can be tailored to protect against specific environmental and/or physical risks to the core, cladding and coating that may be encountered and/or anticipated in a specific use for the cable. The use of the thixotropic gel provides the dual benefit of adding in the manufacture of the cable as well as providing mechanical protection to the core once the cable manufacturing is completed.

**[00125]** The second protective layer may be a stainless steel tube composed of 316 stainless. The second protective layer may provide physical strength to the fiber over great distances, as well as, protection from physical damage and the environment in which the cable may be used. The second protective layer may be composed of other materials, such as those disclosed US Patent Application Publication Numbers 2010/0044106, 2010/0044105 and 2010/0215326 and in pending US Patent Application Serial Number 12/840,978 the disclosures of each of which are incorporated herein by reference. The second protective layer thickness may be selected based upon the requirements for use and the environment in which the cable will be used. The thickness may further be dependent upon the weight and strength of the material from which it is made. Thus, the thickness and composition of the second protective layer can be tailored to protect against specific environmental and/or physical risks to the core, cladding and coating that may be encountered and/or anticipated in a specific use for the cable. The presence of, size, configuration and composition of the second protective layer may be based upon or tailored to the design, dimensions, and performance requirements for the conveyance structure that the optical fiber cable may be incorporated into or associated with.

**[00126]** The need for, use of and configuration of the first, second, or additional protective layers may be dependent upon the configuration dimensions and

performance requirements for a conveyance structure that the optical fiber is associated with. One or more of these protective layers, if utilized, may be part of the conveyance structure, integral with the conveyance structure, a separate or separable component of the conveyance structure, and combinations and variations of these.

**[00127]** The optical fiber cables, and the conveyance structures that they may be incorporated into or associated with, can be greater than about 0.5 km (kilometer), greater than about 1 km, greater than about 2 km, greater than about 3 km, greater than about 4 km and greater than about 5 km. These cables and structures can withstand temperatures of up to about 300° C, pressures of up to about 3000 psi and as great as 36,000 psi, and corrosive environments over the length of the fiber without substantial loss of power and for extended periods of time. The optical fiber cables and conveyance structures can have a power loss, for a given wavelength, of less than about 2.0 dB/km, less than about 1.5 dB/km, less than about 1.0 dB/km, less than about 0.5 dB/km and less than about 0.3 dB/km. The optical fiber cables and conveyance structures can have power transmissions of at least about 50%, at least about 60%, at least about 80%, and at least about 90%.

**[00128]** The flexibility and/or stiffness of the optical fiber cable, conveyance structure or both, can be varied based upon the size and types of materials that are used in the various layers of the cable and structure. Thus, depending upon the application a stiffer or more flexible optical fiber cable, conveyance structure or both, may be desirable. For some applications it is preferred that the optical fiber cable, conveyance structure or both, have sufficient flexibility and strength to be capable of being repeatedly wound and unwound from a spool or reel having an outside diameter of no more than about 6 m. This outside diameter spool size can be transported by truck on public highways. Thus, a spool or reel having an outside diameter of less than about 6 meters and comprising between 0.5 meters and 5 km of the optical fiber cable or structure may be utilized. The spool or reel may have an outside diameter of less than about 6 meters, less than about 3 meters, and less than about 2 meters, and comprising greater than about 0.5 km (kilometer), greater than about 1 km, greater than about 2 km, greater than about 3 km, greater than about 4 km and greater than about 5 km in length of the optical fiber cable, conveyance structure or both.



**[00129]** An example of an embodiment of the optical fiber cable, that may be or be part of a conveyance structure, would be a fused silica core of about 600 microns diameter, a fluorine doped fused silica cladding, having a thickness of 60 microns, a high temperature Acrylate coating having a thickness of about 90 microns, a thixotropic gel or a TEFLON sleeve first protective layer having a thickness of about 2500 microns, and a 316 stainless steel second protective layer having an outer diameter of about 6250 microns and a length of about 2 km. The length of the fiber structure includes the core, cladding and coating is longer than the length of the stainless steel protective layer. This difference in length addresses any differential stretch of the stainless steel relative to the stretch of the fiber structure when the cable is in a hanging position, or under tensions, such as when it is extended down a well bore. The fiber has a numerical aperture of at least about 0.14. The fiber of this example can transmit a laser beam (wavelength 1080 nm) of about 20 kW (kilowatt) power, from the preferred laser, over a distance of about 2 km in temperatures of up to about 200° C and pressures of about 3000 psi with less than 1 dB/km power loss.

**[00130]** Another example of an embodiment of an optical fiber cable, that may be or be part of a conveyance structure, would have a fused silica core of about 500 microns diameter, a fluorine doped fused silica cladding, having a thickness of 50 microns, an Acrylate coating having a thickness of about 60 microns, and an 1/8 inch outer diameter stainless steel protective layer and a length of about 2 km. The fiber has a numerical aperture (NA) of 0.22. The fiber of this example transmitted a laser beam (wavelength 1080 nm) of about 10 kW (kilowatt) power, from the preferred laser, over a distance of about 2 km in temperatures of up to about 150 C° and at ambient pressure and with less than 0.8 dB/km power loss. This fiber was tested using an IPG YLR 20000 laser was operated a duty cycle of 10% for a 1 kHz pulse rate. The operating conditions were established to keep the pulse duration longer than the time constant for SBS. Thus, the absence of SBS was the result of the fiber and laser, not the pulse duration. The laser beam was transmitted through a 2 km fiber, evaluated in a test system along the lines of the test system shown in Figure 3 of US Patent Publication Number 2010/0215326 and provided the results set forth in Table 4, where peak power launched and power output are in watts.

[00131] Table 4.

Peak Power Launched	Peak Power Output	Percentage transmitted
924	452	48.9
1535	864	56.3
1563	844	54.0
1660	864	52.0
1818	970	53.3
1932	1045	54.1
2000	1100	55.0
2224	1153	51.8
2297	1216	52.9
2495	1250	50.1
2632	1329	50.5
2756	1421	51.6
3028	1592	52.6
3421	1816	53.1
3684	1987	53.9
3947	2105	53.3
4342	2263	52.1
4605	2382	51.7
4868	2487	51.1

[00132] The spectrum for 4868 Watt power is shown at FIG. 2. The absence of SRS phenomenon is clearly shown in the spectrum. (As used herein terms such as, "absence of", "without any" or "free from" a particular phenomena or effect means that for all practical purpose the phenomena or effect is not present, and/or not observable by ordinary means used by one of skill in the art) Further the linear relationship of the launch (input) and output power confirms the absence of SBS phenomena. Further, the pulsed operation of the laser may have caused the wavelength of the fiber laser to chirp, which may have further contributed to the suppression of SBS and SRS phenomenon since this would result in an effectively wider laser linewidth.

[00133] Turning to FIG. 3 there is provided a general configuration of an embodiment of a laser system. The arrangement of the components and structures in this embodiment is by way of example, it being recognized that these components may be arrange differently on the truck chassis, or that different types of chassis and sizes may be used as well as different components.

**[00134]** In particular, in the embodiment of FIG 3. there is provided a mobile high power laser beam delivery system 300. In the embodiment there is shown a laser cabin or room 301. There is provided a source of electrical power 302, which may be a generator or electrical connection device for connecting to a source of electricity. The laser room 301 houses a laser source, which in this embodiment is a 20 kW laser having a wavelength of about 1070-1080, (other laser sources, types, wavelengths, and powers may be utilized, and thus the laser source may be a number of lasers, a single laser, or laser modules, collectively having at least about 5 kW, 10 kW, 20 kW, 30 kW 40 kW, 70 kW or more power), which is preferably capable of being integrated with a control system for an assembly to pay out and retrieve the conveyance structure, and any high power laser tool that may be used in conjunction with the system. Examples of high power laser tools are provided in US Patent Applications Serial Number 61/378,910, Serial Number 61/374,594, and Serial Number 61/446,421, the entire disclosure of each of which is incorporated herein by reference.

**[00135]** A high power fiber 304 leaves the laser room 301 and enters an optical slip ring 303, thus optically associating the high power laser with the optical slip ring. The fiber 304 may be by a commercially available industrial hardened fiber optic cabling with QBH connectors at each end. Within the optical slip ring the laser beam is transmitted from a non-rotating optical fiber to the rotating optical fiber that is contained within the conveyance structure 306 that is wrapped around spool 305. The conveyance structure 306 is associated with cable handling device 307, which may be a hydraulic boom crane or similar type device, that has an optical block 308. The optical cable block 308 provides a radius of curvature when the optical cable is run over it such that bending and other losses are minimized. The distal end of the conveyance structure 306 has a connecting apparatus 309, which could be a fiber that is fused to a fiber in a tool or other laser equipment, a fiber termination coupled to mechanical connecting means, a commercially available high power water cooled connector, or more preferably a connector of the type provided in US Patent Application serial number 61/493,174, the entire disclosure of which is incorporated herein by reference.

**[00136]** The optical block may be an injector, a sheave, or any other free moving, powered or similar device for permitting or assisting the conveyance structure

to be paid out and retrieved. When determining the size, e.g., radius of curvature, of the spool, the optical block or other conveyance structure handling devices care should be taken to avoid unnecessary bending losses, such as macro- and micro- bending losses, as well as, losses from stress and strain to the fiber, as for example taught in US Patent Application Serial Number 12/840,978 the entire disclosure of which is incorporated herein by reference. The conveyance structure has a connector/coupler device 309, that is optically associated with the optical fiber and that may be attached to, e.g., optically or optically and mechanically associated with, a high power laser tool, another connector, an optical fiber or another conveyance structure. The device 309 may also mechanically connect to the tool, a separate mechanical connection device may be used, or a combination mechanical-optical connection device may be used. Examples of such connectors are contained in US Patent Application Serial Number 61/493,174, the entire disclosure of which is incorporated herein by reference.

**[00137]** The conveyance structure 306 on spool 305 has at least one high power optical fiber, and may have additional fibers, as well as, other conduits, cables, channels, etc., for providing and receiving material, data, instructions to and from the high power laser tool, monitoring conditions of the system and the tool and other uses. Although this system is shown as truck mounted, it is recognized the system could be mounded on, or in other mobile or moveable platforms, such as a skid, a shipping container, a boat, a barge, a rail car, a drilling rig, a work over rig, a work over truck, a drill ship, a fixed platform, or it could be permanently installed at a location.

**[00138]** The spool may have a conveyance structure wound around the spool, the conveyance structure being capable of being unwound from and wound onto the spool, and thus being rewindable. The conveyance structure having a length greater than about 0.5 km, about 1 km, about 2 km, about 3 km and greater and may have: a core; a cladding; a coating; a first protective layer; and, a second protective layer. The conveyance structure may be capable of transmitting high power laser energy for its length with a power loss of less than about 2 dB/km and more preferably less than about 1 dB/km and still more preferably less than about 0.5 dB/km and yet more preferably about 0.3 dB/km. The outer diameter of the spool when wound is preferably less than about 6 m (meters) to facilitate transporting of the spool by truck.

**[00139]** The conveyance structure handling apparatus may be a part of, associated with, independent from, or function as an optical block. The handling apparatus may be, for example, a spool. There are many varied ways and configurations to use a spool as a handling apparatus; although, these configurations may be generally categorized into two basic spool approaches.

**[00140]** The first approach is to use a spool, which is simply a wheel with conveyance structure coiled around the outside of the wheel. For example, this coiled conveyance structure may be a hollow tube, a composite tube, a complex walled tube, it may be an optical fiber, it may be a bundle of optical fibers, it may be an armored optical fiber, it may be other types of optically transmitting cables or it may be a hollow tube that contains the aforementioned optically transmitting cables.

**[00141]** In this first general type of spool approach, the spool in this configuration has a hollow central axis, or such an axis is associated with the spool, where the optical power is transmitted to the input end of the optical fiber. The beam will be launched down the center of the spool, the spool rides on precision bearings in either a horizontal or vertical orientation to prevent any tilt of the spool as the fiber is spooled out. It is optimal for the axis of the spool to maintain an angular tolerance of about +/- 10 micro-radians, which is preferably obtained by having the optical axis isolated and/or independent from the spool axis of rotation. The beam when launched into the fiber is launched by a lens which is rotating with the fiber at the Fourier Transform plane of the launch lens, which is insensitive to movement in the position of the lens with respect the laser beam, but sensitive to the tilt of the incoming laser beam. The beam, which is launched in the fiber, is launched by a lens that is stationary with respect to the fiber at the Fourier Transform plane of the launch lens, which is insensitive to movement of the fiber with respect to the launch lens.

**[00142]** The second general type of spool approach is to use a stationary spool similar to a creel and rotate the distal end of the structure or the laser tool attached to the distal end of the fiber in the structure, as the conveyance structure spools out to keep the conveyance structure and thus the fiber from twisting as it is extracted from the spool. If the fiber can be designed to accept a reasonable amount of twist along its length, then this may be the preferred method. Using this type of the second approach

if the conveyance structure, and thus, the fiber could be pre-twisted around the spool then as the conveyance structure and the fiber are extracted from the spool, the conveyance structure straightens out and there is no need for the fiber and in particular its distal end to be rotated as the conveyance structure is paid out. There may be a series of tensioners that can suspend the fiber down the hole, or if the hole is filled with water to extract the debris from the bottom of the hole, then the fiber can be encased in a buoyant casing that will support the weight of the fiber and its casing the entire length of the hole. In the situation where the distal end does not rotate and the fiber is twisted and placed under twisting strain, there will be the further benefit of reducing SBS as taught herein.

**[00143]** The handling apparatus may have QBH fibers and a collimator. Vibration isolation means are also desirable in the construction of the handling apparatus, and in particular for a fiber slip ring. Thus, using the example of a spool, the spool's outer plate may be mounted to the spool support using a Delrin plate, while the inner plate floats on the spool and pins rotate the assembly. The fiber slip ring is the stationary fiber, which communicates power across the rotating spool hub to the rotating fiber.

**[00144]** When using a spool the mechanical axis of the spool is used to transmit optical power from the input end of the optical fiber to the distal end. This calls for a precision optical bearing system (the fiber slip ring) to maintain a stable alignment between the external fiber providing the optical power and the optical fiber mounted on the spool. The laser can be mounted inside of the spool, or other handling apparatus, or on a device that rotates the laser as the spool or other handling apparatus is rotated. As shown for example in FIG. 13 the laser can be mounted external to the spool or if multiple lasers are employed both internal and external laser locations may be used. The internally, e.g., rotationally, mounted laser may, for example, be a high power laser for providing the high power laser beam for the remote laser activities, it may be a probe or monitoring laser, used for analysis and monitoring of the system and methods performed by the system or it may be both. Further, sensing and monitoring equipment may be located inside of, or otherwise affixed to, the rotating elements of the spool, or other handling apparatus.

**[00145]** There is further provided a rotating coupler, that may be used with some handling apparatus, to connect the conveyance structure, which is rotating, to the laser beam transmission fiber and any fluid or electrical conveyance conduits, which are not rotating. As illustrated by way of example in FIG. 8, a spool of coiled tubing 809 has two rotating coupling means 813. One of said coupling means has an optical rotating coupling means 802 and the other has a fluid rotating coupling means 803. The optical rotating coupling means 802 can be in the same structure as the fluid rotating coupling means 803 or they can be separate. Thus, preferably, two separate coupling means are employed. Additional rotating coupling means may also be added to handle other cables, such as for example cables for downhole probes.

**[00146]** The optical rotating coupling means 802 is connected to a hollow precision ground axle 804 with bearing surfaces 805, 806. The laser transmission means 808 is optically coupled to the hollow axle 804 by optical rotating coupling means 802, which permits the laser beam to be transmitted from the laser transmission means 808 into the hollow axle 804. The optical rotating coupling means for example may be made up of a QBH connector, a precision collimator, and a rotation stage, for example a Precitec collimator through a Newport rotation stage to another Precitec collimator and to a QBH collimator. To the extent that excessive heat builds up in the optical rotating coupling cooling should be applied to maintain the temperature at a desired level.

**[00147]** The hollow axle 804 then transmits the laser beam to an opening 807 in the hollow axle 804, which opening contains an optical coupler 810 that optically connects the hollow axle 804 to the long distance high power laser beam transmission means 825 that may be located inside of a tubing 812. Thus, in this way the laser transmission means 808, the hollow axle 804 and the long distance high power laser beam transmission means 825 are rotatably optically connected, so that the laser beam can be transmitted from the laser to the long distance high power laser beam transmission means 825.

**[00148]** A further illustration of an optical connection for a rotation spool is provided in FIG. 6, wherein there is illustrated a spool 600 and a support 601 for the spool 600. The spool 600 is rotatably mounted to the support 601 by load bearing bearings 602. An input optical cable 603, which transmits a laser beam from a laser

source (not shown in this figure) to an optical coupler 605. The laser beam exits the connector 605 and passes through optics 609 and 610 into optical coupler 606, which is optically connected to an output optical cable 604. The optical coupler 605 is mounted to the spool by a preferably non-load bearing 608 (e.g., the bearing 608 is not carrying, or is isolated or at least partially isolated from, the weight of the spool assembly), while coupler 606 is mounted to the spool by device 607 in a manner that provides for its rotation with the spool. In this way as the spool is rotated, the weight of the spool and coiled tubing is supported by the load bearing bearings 602, while the rotatable optical coupling assembly allows the laser beam to be transmitted from cable 603 which does not rotate to cable 604 which rotates with the spool.

**[00149]** In addition to using a rotating spool of tubing, another device to pay out and retrieve, or for extending and retrieving, the conveyance structure is a stationary spool or creel. As illustrated, by way of example, in FIGS. 9A and 9B there is provided a creel 909 that is stationary and which contains coiled within the long distance high power laser beam transmission means 925. That means is connected to the laser beam transmission conveyance structure 908, which is connected to the laser (not shown in this figure). In this way the laser beam may be transmitted into the long distance high power laser beam transmission fiber associated with, or being, the conveyance structure and that structure may be deployed down a borehole, or to a remote location where the high power laser energy may be utilized, by for example a high power laser tool. The long distance high power laser beam transmission conveyance structure may be for example, a coiled tubing, line structure, or composite tube, on the creel. The optical fiber associated therewith may preferably be an armored optical fiber of the type provided herein. In using the creel consideration should be given to the fact that the conveyance structure and thus the optical fiber will be twisted when it is deployed. To address this consideration the distal end of the fiber, the conveyance structure, the bottom hole assembly, or the laser tool, may be slowly rotated to keep the optical cable untwisted, the conveyance structure may be pre-twisted, the conveyance structure and optical fiber may be designed to tolerate the twisting and combinations and variations of these.



**[00150]** In FIG. 10 there is provided a conveyance structure handling apparatus 1000 having a housing 1020 and an opening 1021. Apparatus 1000 has an assembly 1021 for winding and unwinding the high power conveyance structure 1010. The assembly 1021 has roller 1022, 1023. In this embodiment the structure is stored in a helix 1025 that can be unwound and rewound as the tool is deployed and recovered. The distal end of the conveyance structure has a connecting apparatus 1030, which could be a fiber that is fused to a fiber in a tool or other laser equipment, a fiber termination coupled to mechanical connecting means, a commercially available high power water cooled connector, or more preferably a connector of the type provided in US Patent Application serial number 61/493,174, the entire disclosure of which is incorporated herein by reference. The proximal end 1040 may be optically associated with a high power laser source.

**[00151]** This type of device could be mounted with the laser as a modular system, an integrated system, a unified mobile system, or separate from and optically associable with a high power laser or laser cabin.

**[00152]** The embodiment of FIG. 10, and the embodiment of FIGS 9, do not require an optical slip ring in order to have the high power laser maintained in optical association with the conveyance structure as it is paid and retrieved. In the handling apparatus configurations, such as the rotating spool, in general, an optical slip ring is used, as described above, to enable the laser to be maintained in optical association with the conveyance structure, and the structures distal end and laser tool, while the conveyance structure is being paid out and retrieved. It being understood that in such rotating spool type structures, the optical slip ring may not be used, in which case the conveyance structure would be wound out to a desired length, or depth, and then the high power laser would be optically connected to its proximal end, e.g., the end remaining on the spool. Preferably the unwound length of conveyance structure would be slightly greater than, or greater than the depth, or distance to the work site location, so that sufficient extra unwound conveyance structure would be present to move the laser tool in any manner needed to perform an intended laser operation, such as for example, up and down within the borehole to cut a window.

**[00153]** In FIG. 11 there is provided an embodiment of a handling apparatus that is configured to provide figure-8 looped wraps. This configuration does not require an optical slip ring and does not place twist in the conveyance structure. Thus, in FIG. 11 there is provided a Figure-8 looping apparatus 1112 having a base 1101. The base has two wrapping posts 1105, 1106. The conveyance structure 1102 has a proximal end 1103, which may be connected to a high power laser or laser cabin, and a distal end 1104, which is paid out and may be associated with a laser tool. As shown in FIG. 11, the conveyance structure is formed into several figure-8 loops, one located above the next. Thus, for purpose of illustration, four such loops are shown: a first loop 1107 which is lowest and adjacent the base 1101; a second loop 1108, which is generally above the first loop 1107, a third loop 1109, which is generally above the second loop 1108, and a fourth loop 1110, which is generally above the third loop 1109. Although four loops are shown, it is understood that for a conveyance structure a km or longer, many more, hundreds and potentially thousands, of such figure-8 loops will be present.

**[00154]** In FIGS. 12A, 12B, and 12C there is provided an embodiment of a handling apparatus. In this embodiment a reverse wrap conveying structure is utilized. Thus, there is a reverse wrap conveying structure 1200 having a first preformed helical section 1201, a second helical section 1202, which is an opposite helix from the first. These sections are connected by a flip back hinge like section 1203. Several passages may be contained within this structure, for example a high pressure air conduit 1205, a high power laser fiber 1206, an electrical cable 1207, and a monitoring laser fiber 1208. The hardware and outer components for this type of reverse wrap conveying structure may be obtained from Igus, under the trade name TWISTERBAND. This type of reverse wrap conveying structure is an example of a conveying structure that can also function as a handling apparatus.

**[00155]** By way of example, the conveyance structures whether or not associated with handling apparatus can range in lengths from: 1 km (3,280 ft) to 9 km (29,528 ft); from 2 km (6,561 ft) to 5 km (16,404 ft); at least about 5 km (16,404 ft); and from about 5 km (16,404 ft) to at least about 9 km (29,528 ft).

**[00156]** In FIG. 13 there is provided a schematic drawing of an embodiment of a laser system 1312, having a laser room or cabin 1300 and a spool 1301. In this

embodiment the laser room 1300 contains a high power beam switch 1302, a high power laser unit 1303 (which could be a number of lasers, a single laser, or laser modules, collectively having at least about 5 kW, 10 kW, 20 kW, 30 kW 40 kW, 70 kW or more power), a chiller assembly 1304 for the laser unit 1303 and a control console 1305 that preferably is in control communication with a control system and network 1310. Additionally multiple laser may be combined with a high power beam combiner to launch about 40 kW, about 60 kW about 80 kW or greater down a single fiber. Although shown has having all of the components of the chiller in the room (in which case the air inflows and outflows would have to vented to the outside, which venting is not shown in this schematic), the larger components of the chiller 1304, such as the heat exchanger components, may be located outside of the laser room 1300, both for space, noise and heat management purposes. The high power laser unit 1303 is optically connected to the beam switch 1302 by high power optical fiber 1306. The beam switch 1302 optically connects to spool 1301 by means of an optical slip ring 1308, which in turn optically and rotationally connects to the conveyance structure 1309. In higher power systems, e.g., greater than 20 kW the use of multiple fibers, multiple beam switches, and other multiple component type systems may be employed. These may, among other things provide greater safety and reliability to such higher power systems. The conveyance structure is then capable of being attached to a high power laser tool or other high power laser device. The distal end of the conveyance structure 1309 has a connecting apparatus 1340, which could be a fiber that is fused to a fiber in a tool or other laser equipment, a fiber termination coupled to mechanical connecting means, a commercially available high power water cooled connector, or more preferably a connector of the type provided in US Patent Application serial number 61/493,174, the entire disclosure of which is incorporated herein by reference.

**[00157]** A second conveyance structure 1311, which could also be an optical fiber, leaves the beam switch 1302. This second conveyance structure 1311 could be used with a different spool for use with a different tool, directly connect to a tool, or connected to a separate high power laser lab., tool testing, or work area (not shown in this figure). Electrical power can be supplied from the location where the laser room is located, from the mobile unit that transported the laser room, from separate generators,

separate mobile generators, or other sources of electricity at the work site or bought to the work site.

**[00158]** Preferably in a high power laser system a controller is in communication, via a network, cables fiber or other type of factory, marine or industrial data and control signal communication medium with the laser tool and potentially other systems at a work site. The controller may also be in communication with a first spool of high power laser cable, a second spool of high power laser cable and a third spool of high power laser cable, etc. Examples of control systems and networks for high power laser systems are provided in US Patent Application Serial Number 61/446,412 the entire disclosure of which is incorporated herein by reference.

**[00159]** It should be noted that the configuration, placement, number, and specific types of equipment in a high power laser system, a mobile laser structure, a laser cabin, or a handling apparatus are not limited to the exemplary embodiments that are provided herein and are not limited to the illustrations in the figures provided herein. Thus, it is envisioned and contemplated by this specification that different and varied combinations, arrangements, placements, numbers, and types of equipment may be utilized without departing from the spirit and teaching of this specification.

**[00160]** The following Examples 1 to 13 and 22 to 23, provide embodiments of conveyance structures. Other composite tube structures, such as those disclosed in US. Patent Number 7,647,948, the entire disclosure of which is incorporated herein by reference, may have high power long distance laser fibers associated with them and thus be a conveyance structure. It should be noted that the configuration, placement, number, and specific types of components of conveyance structures are not limited to the exemplary embodiments that are provided in Examples 1 to 13, and 22 to 23. Thus, it is envisioned and contemplated by this specification that different and varied combinations, arrangements, placements, numbers, and types of components may be utilized in a conveyance structure without departing from the spirit and teaching of this specification. Additionally, these conveyance structures may be used with different and varied types of handling apparatus, mobile laser systems and optical blocks.

**[00161]** Conveyance structures and their components may be made from various types of material including metals, plastics and composites. The materials of

construction should be selected to meet particular intended use requirements and may take into consideration factors such as pressure (internal and external), flow rates, temperatures, corrosive environments, stress and strain. Thus, they may be for example: a metal tube; a braided tube; a composite material and combinations and variations of these. They may be made from metals such as for example: steel; stainless steel; aluminum; titanium; phosphor bronze; copper; bronze; inconel; and monel. They may be made for example from composites such as: carbon fiber; fiberglass; Kevlar; Aramid; Boron fibers; metal matrix composites; cermet (ceramic metal); nanocomposites; matrix-resin solutions (e.g., polyester (isophthalic and orthophthalic); vinyl ester; epoxy; phenolic; polyimide; cyanate-ester-based; and acrylate-based. They may be made from polymers, such as: Acetal polymers (e.g., delrin; acetal copolymer; or turcite); PEEK including filled versions; Polyamide-imide (Torlon); Polystyrene; polycarbonate; Polypropylene; PPS (e.g., Techtron; Fortron; Ryton); Polyethylene (e.g., LDPE; HDPE; UHMW; VHMW); Polyester (e.g., PET; PETG; Hydex); PVC; Radel; Acrylic; ABS; Garolite; Nylon; fluoropolymers (e.g., TEFLON; FEP; ETFE; CTFE; ECTFE (Halar); Rulon; PTFE; PFA; PVDF (Kynar); and FEP). They may be made from or use materials such as: fiberglass; fiberglass reinforced in epoxy resin matrix; carbon fiber; electrical grade glass; Kevlar (aramid fiber); epoxy resins; fiberglass reinforced thermoset polyester; polyester; vinyl ester; plastic; glass reinforced plastic; high density polyethylene; fluoroplastic; thermalplastic,s as well as other materials, compositions and structures that that may be used for such members, or are otherwise known to, or later developed by, those of skill in the art.

**[00162]** The conveyance structures of Examples 1 to 13, and 22 to 23 may be greater than 0.5 km, greater than 1 km, greater than 2 km, greater than 3 km, and greater than 5 km in length. By way of example, these structure may use a high power optical fiber having . . Pull from connector application .

**[00163]** EXAMPLE 1

**[00164]** An embodiment of a conveyance structure is provided in Fig. 14. A wireline conveyance structure 1450 having two layers of helically wound armor wires, an outer layer 1451 and an inner layer 1452 are present. The conveyance structure 1450 has a plurality of insulated electrical conductors 1453 and a high power optical

fiber capable of reducing non-linear effects 1454, which has an optical fiber 1455 and an outer protective member 1456. The space 1458 between the outer surface of the fiber and the inner surface of the protective member, may further be filled with, or otherwise contain, a gel, protective sleeve, an elastomer or some other material, such as a liquid (provided the liquid does not damage the fiber, *e.g.*, through for example hydrogen migration or solvent effects). Similarly, a second space 1459 may further be filled with, or otherwise contain, a gel, an elastomer or some other material, such as a fluid, which material will prevent the armor wires from crushing inwardly from external pressure of an application, such as the pressure found in a well bore. Further the fiber may be packaged in a TEFLON sleeve or equivalent type of material or sleeve.

**[00165]** EXAMPLE 2

**[00166]** An embodiment of a conveyance structure is provided in Fig. 15, which illustrates a wireline type conveyance structure 1560 having outer armor wire layer 1561 and inner armor wire layer 1562. The conveyance structure 1560 has a high power optical fiber 1565 and an outer protective member 1566. The space 1569 between the optical fiber 1565 and the outer protective member 1566 may further be filled with, or otherwise contain, a gel, a protective sleeve, an elastomer or some other material, such as a liquid (provided the liquid does not damage the fiber, *e.g.*, through for example hydrogen migration or solvent effects), which material will prevent the armor wires from crushing inwardly from external pressure of an application, such as the pressure found in a well bore. Further the fiber may be packaged in a TEFLON sleeve or equivalent type of material or sleeve.

**[00167]** EXAMPLE 3

**[00168]** An embodiment of a conveyance structure is provided in FIG. 16. This embodiment has a conveyance structure 1606, having an inner member 1621, *e.g.*, a tube, the inner member 1621 having an open area or open space 1622 forming a channel, passage or flow path. The conveyance structure 1606 has a plurality of lines 1623, *e.g.*, electric conductors, hydraulic lines, tubes, data lines, fiber optics, fiber optics data lines, high power optical fibers capable of suppressing or managing non-linear effects, and/or high power optical fibers in a metal tube, TEFLON sleeve, or other protective layer. The conveyance structure 1606 has an outer member 1625. The inner

member 1621 and the outer member 1625 may be made from the same material and composition, or they may be different materials and compositions. The area between the outer member 1625 and the inner member 1621 is filled with and/or contains a supporting or filling medium 1624, *e.g.*, an elastomer or the same or similar material that the inner member and/or outer member is made from. In the configuration of this embodiment the lines are positioned such that they are outward of and surround the inner member.

**[00169]** EXAMPLE 4

**[00170]** An embodiment of a conveyance structure is provided in Fig. 17. The conveyance structure 1706 has two inner members, 1731a and 1731b, *e.g.*, tubes. The inner members 1731a and 1731b forms an open area, or channel, or flow path 1732a, 1732b. The conveyance structure 1706 has a plurality of lines 1733, *e.g.*, electric conductors, hydraulic lines, tubes, data lines, fiber optics, fiber optics data lines, high power optical fibers capable of suppressing or managing non-linear effects, high power optical fibers, and/or high power optical fibers in a metal tube, TEFLON sleeve, or other protective layer. The structure 1706 has an outer member 1735. The area between the outer member 1735 and the inner members 1731a and 1731b is filled with and/or contains a supporting medium 1734, *e.g.*, an elastomer or the same or similar material that the inner member and/or outer member is made from. In the configuration of this embodiment the lines are positioned such that they are outward of and surround the inner members.

**[00171]** EXAMPLE 5

**[00172]** An embodiment of a conveyance structure is provided in FIG. 18. The conveyance structure 1806, has inner members, 1841a and 1841b, *e.g.*, a tubes, the inner members 1841a and 1841b having an open area or open space 1842a, 1842b associated therewith, which space forms a channel, passage or flow path. The conveyance structure 1806 has a plurality of lines 1843, *e.g.*, electric conductors, hydraulic lines, tubes, data lines, fiber optics, fiber optics data lines, high power optical fibers capable of suppressing or managing non-linear effects, high power optical fibers, and/or high power optical fibers in a metal tube, TEFLON sleeve, or other protective layer. The conveyance structure 1806 has an outer member 1845. The area between

the outer member 1845 and the inner members 1841a and 1841b is filled with and/or contains a supporting medium 1844, *e.g.*, an elastomer or the same or similar material that the inner member and/or outer member is made from. The inner members and the outer member may be made of the same or different materials, including the materials listed in Example 3. In the configuration of this embodiment the lines are positioned such that they are between the inner members.

**[00173]** EXAMPLE 6

**[00174]** An embodiment of a conveyance structure is provided in FIG. 19. The conveyance structure 1906 has an inner member 1951, *e.g.*, a tube. The inner member 1951 has an open area or open space 1952, which space forms a channel, cavity, flow path, or passage. The conveyance structure 1906 has a plurality of lines 1953, *e.g.*, electric conductors, hydraulic lines, tubes, data lines, fiber optics, fiber optics data lines, high power optical fibers capable of suppressing or managing non-linear effects, high power optical fibers, and/or high power optical fibers in a metal tube, TEFLON sleeve, or other protective layer. The conveyance structure 1906 has an outer member 1955. The area between the outer member 1955 and the inner member 1951 is filled with and/or contains a supporting medium 1954, *e.g.*, an elastomer or the same or similar material that the inner member and/or outer member is made from. In the configuration of this embodiment the lines are positioned such that they are directly adjacent the inner and outer members.

**[00175]** EXAMPLE 7

**[00176]** An embodiment of a high power conveyance structure is provided in FIGS. 20A and 20B. There is shown a cross section and side view (FIG. 20B) of a composite conveyance structure. In Fig. 20A there is provided a cross-section of a composite conveyance structure 2000. There is an extruded inner member 2002, having an open space 2001, which forms a channel, passage, or flow path. Around the extruded core, preferably in a spiral fashion, lines 2003 and 2004 are positioned around and along the extruded inner member 2002. Line 2003 is a high power laser fiber having a core diameter of 1,000 microns, a dual clad and a TEFLON protective sleeve and Line 2004 is an electrical power cable. A high density polymer 2005 then coats and encapsulates the lines 2003, 2004 and the extruded inner member 2002. The high



density polymer 2005 forms an outer surface 2006 of the composite tube 2000. Fig. 20B shows a section of the conveyance structure 2000, with the lines 2003, 2004 wrapped around the extruded tube 2002. The high density polymer 2005 and outer surface 2006 are shown as phantom lines, so that the spiral arrangement of lines 2003, 2004 can be seen.

**[00177] EXAMPLE 8**

**[00178]** An embodiment of a carbon composite conveyance structure is provided in FIG. 21. The carbon composite conveyance structure 2101 has a body 2102 that has an inner side 2104, and an outer side 2103. The body forms an inner opening 2105, which provides a flow path for drilling or cutting media, such as mud, nitrogen, or air. Contained within the body 2102 are data and/or control lines 2106, 2107, and 2018. These lines may be wires, optical fibers or both for transmitting and receiving control signals and operating data. A high power optical fiber 210, contained within a 0.125" stainless steel tubing 2019 is contained within the body 2102. Clean gas, air, nitrogen or a liquid (provided the liquid does not damage the fiber, e.g., through for example hydrogen migration or solvent effects; if the fluid is present in the laser beam path the fluid should also be selected to be highly transmissive to the wavelength of the laser beam being utilized) may be flowed down the annulus between the inner surface of the stainless tube 2110 and the outer surface of the optical fiber 2110. This flow may be used to cool, pressurize, or clean downhole high power optics. If the flow is across the laser beam path the flow material should be selected to minimize the materials absorbance of the laser beam. Large gauge electrical power wires 2111, 2112 are contained within the body 2102 and may be used to provide electrical power to a tool, cutting tool, drilling tool, tractor, or other downhole or remote piece of equipment.

**[00179] EXAMPLE 9**

**[00180]** An embodiment of a conveyance structure is provided in FIG. 22. The conveyance structure 2201 has a body 2202 that has an inner side 2204, and an outer side 2203. The body forms an inner opening 2205 and a first ear or tab section 2213 and a second ear or tab section 2214. The body is solid and may be made from any of the materials discussed above that meet the intended use or environmental requirements for the structure. The opening 2205, is formed by an inner member 2220,

which may be a composite tube, and provides a flow path for drilling or cutting media, such as mud, nitrogen, or air. Contained within tab 2213 of body 2202 are data and/or control lines 2206, 2207, and 2218. These lines may be wires, optical fibers or both for transmitting and receiving control signals and operating data. A high power optical fiber 2210, contained within a 0.125" stainless steel tubing 2219 is contained within tab 2214 of body 2202. Clean gas, air, nitrogen or a liquid (provided the liquid does not damage the fiber, e.g., through for example hydrogen migration or solvent effects; if the fluid is present in the laser beam path the fluid should also be selected to be highly transmissive to the wavelength of the laser beam being utilized) may be flowed down opening 2218 that is formed by the inside 2217 of 0.50 stainless steel tubing 2215. The tubing 2215 has an outer side 2216, which is in contact with the body 2214. This flow may be used to cool, pressurize, or clean downhole high power optics and/or it may be used to form a jet to assist in laser cutting or drilling. If the flow is across the laser beam path the flow material should be selected to minimize the materials absorbance of the laser beam. Large gauge electrical power wires 2211, 2212 are contained within tab 2213 of the body 2202 and may be used to provide electrical power to a tool, cutting tool, drilling tool, tractor, or other downhole or remote piece of equipment.

**[00181]** In embodiments, such as that of Example 9, the use of a plastic or polymer to form the inner surface of the passage conveying the clean gas flow, provide the ability to have very clean gas, which has advantages when the clean gas is in contact with optics, the laser beam path or both.

**[00182]** EXAMPLE 10

**[00183]** An embodiment of a conveyance structure is provided in FIG. 23. The conveyance structure 2301 has a steel coiled tubing 2302 which forms a passage, flow path or channel 2310. Contained within channel 2310 is a composite pipe 2303, which forms a passage, flow path or channel 2309. Channel 2310 may be used to transmit drilling or cutting material such as mud, air or nitrogen. Channel 2309 contains a 1/8" stainless steel tube 2304 holding a high power laser optical fiber 2311. Also contained within channel 2309 are data lines 2308, 2307 and electrical power lines 2305, 2306. Channel 2309 may be used to convey clean fluids, gasses or liquids, that may be used with or in conjunction with the downhole optics and laser beam paths. Depending upon

the intended flow path and the intended association with or interaction with the laser beam path, the fluid should preferably be transmissive, and more preferably highly transmissive to the wavelength of the laser beam intended to be transmitted by fiber 2311. In this embodiment as the coiled steel tubing 2302 is worn out, damaged or fatigued, the composite pipe 2303 can be removed, placed in a new coiled steel tubing, and reused.

**[00184]** EXAMPLE 11

**[00185]** An embodiment of a conveyance structure is provided in FIG. 24. The conveyance structure 2401 has an outside diameter 2404 that is about 0.6836". The conveyance structure 2401 has an outer armor layer having 38 wires 2402 that are spiral wound and have a diameter of 0.0495" and has an inner armor layer having 42 wires 2403 that are spiral wound and have a diameter of 0.0390". Inside of the inner armor are seven 20 AWG conductor wires 2405 and two 0.0625" stainless steel tubes with high power optical fibers 2406. The conveyance structure 2401 has an inner stainless steel tube 2407 having an inner side 2408 and an outer side 2409. The outer side 2409 is adjacent the conductor wires 2405 and the tubes-with-fibers 2406. The area 2411 between the outer side 2409 and the inner armor layer may be filled with an elastomer or a polymer or other similar type of material such as a high density polymeric material. The stainless steel tube 2407 has an outer diameter of 0.375" and its inner side 2408 forms a space 2401 that creates a channel, passage or flow path.

polypropylene a resin, such as protective wires

**[00186]** EXAMPLE 12

**[00187]** An embodiment of a conveyance structure is provided in FIG. 25. The conveyance structure 2501 has an outside diameter 2502 that is about 1.0254". The conveyance structure 2501 has an outer armor layer having 38 wires 2503 that are spiral wound and have a diameter of 0.0743" and has an inner armor layer having 42 wires 2504 that are spiral wound and have a diameter of 0.0585". Inside of the inner armor are eight 20 AWG conductor wires 2507 and two 0.25" stainless steel tubes with high power optical fibers 2505. The conveyance structure 2501 has two inner stainless steel tubes 2506a and 2506b each having an outer diameter of 0.375". The tubes may be used to carry the same or different fluids or materials. In one application the tubes

may be used to carry liquids and/or gasses having different indices of refraction, for example tube 2506a may carry water and tube 2506b may carry an oil. The area 2512 inside of the inner armor layer may be filled with an elastomer or a polymer or other similar type of material such as a high density polymeric material.

**[00188]** EXAMPLE 13

**[00189]** An embodiment of a conveyance structure is provided in FIG. 26. The conveyance structure 2601 has an outside diameter 2602 that is about 1.0254". The conveyance structure 2601 has an outer armor layer having 38 wires 2603 that are spiral wound and have a diameter of 0.0743" and has an inner armor layer having 42 wires 2604 that are spiral wound and have a diameter of 0.0585". Inside of the inner armor are eight 20 AWG conductor wires 2607 and one 0.25" stainless steel tubes with high power optical fibers 2605. The conveyance structure 2601 has two inner stainless steel tubes 2606a and 2606b each having an outer diameter of 0.375". The tubes may be used to carry the same or different fluids or materials. In one application the tubes may be used to carry liquids and/or gasses having different indices of refraction, for example tube 2606a may carry water and tube 2606b may carry an oil. The area 2612 inside of the inner armor layer may be filled with an elastomer or a polymer or other similar type of material such as a high density polymeric material.

**[00190]** Although steel coiled tubing and composite tubing, and combinations of these are contemplated by this specification, composite tubing for use in a conveyance structure may have some advantages in that its use can reduce the size of the rig needed, can reduce the size of the injector or handling apparatus and optical block needed and may also reduce the overall power consumption, e.g., diesel fuel, that is used by the equipment. The inner channels of composite tubing also provide greater control over the cleanliness, and thus, in situations where the channel is in fluid communication with high power laser optics or high power laser beam paths this feature may prove desirable. The composite materials as seen in the above examples have the ability to imbed many different types of structures and components within them, and may be designed to have a memory that either returns the structure to straight for easy of insertion into a borehole, or to a particular curvature, for easy of winding. Composite conveyance structures may be idea for use with laser cutting tools for workover

applications such as cutting and milling and for use with electric motor laser bottom hole assembly boring apparatus. These composite structures provide the ability to have many varied arrangement of components, such as by way of example: a single line (fiber or electric) packaged in a protective member; a single power transmission optical fiber packaged in a protective member; multiple fibers or lines individually packages and wound inside of a composite tube; multiple fiber ribbons (*e.g.*, multiple fibers packaged into a ribbon which is then wound inside of a composite tube); fiber bundles in individual metal tubes which are bundled helically and then would within the composite tube; clean gas purge lines, which are lines to transport nitrogen, or other purge gas material to the laser tools or laser equipment and which would be wound inside of the composite tube; preselected index matching fluid lines to transport optically propertied fluid to the laser tools or laser equipment and which would be would inside of the composite tube.

**[00191]** In some embodiments the conveyance structures may be very light. For example an optical fiber with a Teflon shield may weigh about 2/3 lb per 1000ft, an optical fiber in a metal tube may weight about 2 lbs per 1000ft, and other similar, yet more robust configurations may way as little as about 5 lbs per 1000ft or less, about 10 lbs per 1000ft, or less, and about 100 lbs per thousand feet or less. Should weight not be a factor and for very harsh and/or demanding uses the conveyance structures could weight substantially more.

**[00192]** The following Examples 14 to 22 provide embodiments of high power laser systems having conveyance structures and handling apparatus. It should be noted that the configuration, placement, number, and specific types of components, including the high power laser(s), conveyance structures and handling apparatus are not limited to the exemplary embodiments that are provided in Examples 14 to 22. The conveyance structures of Examples 1 to 13 and 23 to 24, may be used with, or as a part of, the laser systems of Examples 12 to 22. Thus, it is envisioned and contemplated by this specification that different and varied combinations, arrangements, placements, numbers, and types of components may be utilized in high power mobile laser systems without departing from the spirit and teachings of this specification.

**[00193]** EXAMPLE 14

**[00194]** An embodiment of a high power laser system and its deployment in the field are provided in FIGS 27A to 27D. Thus, there is provided a mobile laser conveyance truck (MLCT) 2700. The MLCT 2700 has a laser cabin 2701 and a handling apparatus cabin 2703, which is adjacent the laser cabin. The laser cabin 2701 and the handling cabin 2703 are located on a truck chassis 2704. The MLCT 2700 has associated with it a lubricator 2705, for pressure management upon entry into a well.

**[00195]** The laser cabin 2701 houses a high power fiber laser 2702, (20 kW; wavelength of 1070-1080 nm); a chiller assembly 2706, which has an air management system 2707 to vent air to the outside of the laser cabin and to bring fresh air in (not shown in the drawing) to the chiller 2706. The laser cabin also has two holding tanks 2708, 2709. These tanks are used to hold fluids needed for the operation of the laser and the chiller during down time and transit. The tanks have heating units to control the temperature of the tank and in particular to prevent the contents from freezing, if power or the heating and cooling system for the laser cabin was not operating. A control system 2710 for the laser and related components is provided in the laser cabin 2703. A partition 2711 separates the interior of the laser cabin from the operator booth 2712.

**[00196]** The operator booth contains a control panel and control system 2713 for operating the laser, the handling apparatus, and other components of the system. The operator booth 2712 is separated from the handling apparatus cabin 2703 by partition 2714.

**[00197]** The handling apparatus cabin 2703 contains a spool 2715 (about 6 ft OD, barrel or axle OD of about 3 feet, and a width of about 6 feet) holding about 10,000 feet of the conveyance structure 2717 of Example 11. The spool 2715 has a motor drive assembly 2716 that rotates the spool. The spool has a holding tank 2718 for fluids that may be used with a laser tool or otherwise pumped through the conveyance structure and has a valve assembly for receiving high pressure gas or liquids for flowing through the conveyance structure.

**[00198]** The laser 2702 is optically associated with the conveyance structure 2717 on the spool 2715 by way of an optical fiber and optical slip ring (not shown in the figures). The fluid tank 2718 and the valve assembly 2719 are in fluid communication

with the conveyance structure 2717 on the spool 2715 by way of a rotary slip ring (not shown).

**[00199]** The laser cabin 2710 and handling apparatus cabin 2703 have access doors or panels (not shown in the figures) for access to the components and equipment, to for example permit repair, replacement and servicing. At the back of the handling apparatus cabin 2703 there are door(s) (not shown in the figure) that open during deployment for the conveyance structure to be taken off the spool. The MLCT 2700 has a generator 2721 electrically to provide electrical power to the system.

**[00200]** Turning to FIG. 27D there is shown an embodiment of a deployment of the MLCT 2700. The MLCT 2700 is positioned near a wellhead 2750 having a Christmas tree 2751, a BOP 2752 and a lubricator 2705. The conveyance structure 2717 travels through winder 2729 (*.e.g.*, line guide, levelwind) to a first sheave 2753, to a second sheave 2754, which has a weight sensor 2755 associated with it. Sheaves 2753, 2754 make up an optical block. The weight sensor 2755 may be associated with sheave 2753 or the composite structure 2717. The conveyance structure 2717 enters into the top of the lubricator and is advanced through the BOP 2752, tree 2751 and wellhead 2750 into the borehole (not shown) below the surface of the earth 2756. The sheaves 2753, 2754 have a diameter of about 3 feet. In this deployment path for the conveyance structure the conveyance structure passes through several radii of curvature, *e.g.*, the spool and the first and second sheaves. These radii are all equal to or large than the minimum bend radius of the high power optical fiber in the conveyance structure. Thus, the conveyance structure deployment path would not exceed (*i.e.*, have a bend that is tighter than the minimum radius of curvature) the minimum bend radius of the fiber.

**[00201]** EXAMPLE 15

**[00202]** An embodiment of a high power mobile laser system is shown in FIG. 28. There is provided a mobile high power laser system 2800 having a laser cabin 2801 and an operator booth 2812. The layout and components of the laser cabin 2801 and the operator booth 2812 are similar to those in Example 14. The system 2800 has a crane 2857 and a lubricator 2805. The system 2800 has a bay 2803 for receiving a handling apparatus having a conveyance structure.

**[00203] EXAMPLE 16**

**[00204]** The mobile system of Example 15 in which the handling apparatus of the embodiment of Figure 11 having 10,000 feet of the conveyance structure of Example 17. The conveyance structure is optically associated to the laser without the need for an optical slip ring, and the passages of the conveyance structure are in fluid association with a source of fluid without the need for a rotating slip ring.

**[00205] EXAMPLE 17**

**[00206]** The mobile system of Example 15 in which the handling apparatus of the embodiment of Figure 9 having 11,000 feet of the conveyance structure of Example 9. The conveyance structure is optically associated to the laser without the need for an optical slip ring, and the passages of the conveyance structure are in fluid association with a source of fluid without the need for a rotating slip ring.

**[00207] EXAMPLE 18**

**[00208]** The mobile system of Example 15 in which the bay has been replaced by a handling apparatus cabin having a spool having 15,000 feet of a conveyance structure and a reverse wrap conveying structure of the embodiment shown in FIGS. 12. In this system the conveyance structure would first be deployed (unwound from the spool) to the general depth within a well where the desired laser activity is to take place. Once deployed the proximal end of the conveyance structure (*i.e.*, the end still on, associated with, or near the axle of the spool) would be optically associated with reverse wrap structure, which in turn is optically associated with the laser. In this manner the spool could be further unwound and wound, permitting a laser tool on the distal end of the conveyance structure to be moved upon and down within the well. The reverse wrap structure would prevent any twisting of the conveyance structure as the spool is wound and unwound to move the laser tool within the well bore.

**[00209] EXAMPLE 19**

**[00210]** An embodiment of a mobile conveyance structure handling apparatus is shown in FIG. 29. A trailer 2901 has a spool 2902, having a barrel OD 2903 of about 8 feet and an OD 2904 of about 10 feet. The spool 2902 has an optical slip ring 2905 and a rotary slip ring 2906. The spool 2902 has at least about 4,000 ft of the conveyance structure 2907 of Example 11. The spool has a drive mechanism, which is



not shown in the figure. During deployment, the conveyance structure 2907 unwound and placed over optical block 2710, which is a sheave having an OD of about 6 feet.

**[00211]** In use a mobile laser system would positioned near the trailer 2901 and the laser would be optically associated with the conveyance structure by way of the optical slip ring.

**[00212]** EXAMPLE 20

**[00213]** An embodiment of a mobile laser system is shown in FIG. 30. A trailer 3001 has a spool 3002 having a drum OD of about 10 feet and an OD of about 12 ft and having about 5,000 feet of conveyance structure 3003 (coiled tubing having a protected optical fiber within). The trailer 3001 has a large diameter coil tubing injector 3004, having an OD of about 8 feet.

**[00214]** In use a mobile laser system would positioned near the trailer 3001 and the laser would be optically associated with the conveyance structure by way of the optical slip ring.

**[00215]** EXAMPLE 21

**[00216]** An embodiment of a mobile laser system deployed at a drill site is shown in FIG. 31. A mobile laser system 3100 for performing laser activities such as drilling, workover and completion and flow control, in a borehole 3101 in the earth 3102. FIG. 31 provides a cut away perspective view showing the surface of the earth 3130 and a cut away of the earth below the surface 3102. In general and by way of example, there is provided a source of electrical power 3103, which provides electrical power by cables 3104 and 3105 to a mobile laser 3106 and a chiller 3107 for the laser 3106. The laser provides a laser beam, i.e., laser energy, that can be conveyed by a laser beam transmission means 3108 to a spool of coiled tubing 3109. A source of fluid 3110 is provided. The fluid, e.g., high pressure gas, including air or nitrogen, is conveyed by fluid conveyance means 3111 to the spool of coiled tubing 3109.

**[00217]** The spool of coiled tubing 3109 is rotated to advance and retract the coiled tubing 3112. Thus, the laser beam transmission means 3108 and the fluid conveyance means 3111 are attached to the spool of coiled tubing 3109 by means of rotating coupling means 3113. The coiled tubing 3112 contains a high power optical fiber in a protective tube for transmitting high power laser energy to the laser tool 3114.

The coiled tubing 3112 also contains a means to convey the fluid along the entire length of the coiled tubing 3112 to the laser tool 3114.

**[00218]** Additionally, there is provided a support structure 3115, which holds an injector 3116, to facilitate movement of the coiled tubing 3112 in the borehole 3101. Further other support structures may be employed for example such structures could be derrick, crane, mast, tripod, or other similar type of structure or hybrid and combinations of these. In some applications, as the borehole is advance to greater depths from the surface 1030, the use of a diverter 3117, a blow out preventer (BOP) 3118, and a fluid and/or cutting handling system 3119 may become necessary. The coiled tubing 3112 is passed from the injector 3116 through the diverter 3117, the BOP 3118, a wellhead 3120 and into the borehole 3101. The fluid is conveyed to the laser tool 3114 in the borehole 3101. At that point the fluid exits the laser cutting tool 3114 in association with the laser beam 3124. The wellhead 3120 is attached to casing. For the purposes of simplification the structural components of a borehole such as casing, hangers, and cement are not shown. It is understood that these components may be used and will vary based upon the depth, type, and geology of the borehole, as well as, other factors.

**[00219]** EXAMPLE 22

**[00220]** An embodiment of a laser trailer and mobile optics lab is provided in FIGS. 32A to 32C. A laser trailer 3210 is connected by electric power line 3212 to a generator trailer 3210 (which has a 175 kW diesel generator). The laser trailer 3210 has a high power laser 3203, a chiller 3202. The laser has a high power optical fiber 3213 that is optically associated with the laser and exits the trailer, or end in a connector on the wall of the trail, such that another high power fiber may be optically associated to transmit the high power laser beam to an intended location or equipment, for example the system of Example 19. The laser trailer 3210 may have storage areas 3204, 3208, a work area 3205, for example a desk or work bench, a control panel 3206 having data and control lines 3211, flow bench 3207 and a vibrationally isolated flow bench 3208. The trailer 3210 may also have HVAC unit 3209.

**[00221]** EXAMPLE 23

**[00222]** An embodiment of a conveyance structure is provided in FIG. 33. The conveyance structure 3301 has a support structure 3304 that forms a flow passage

3305. Along the exterior surface of the support structure there are located openings 3302, which form channels along the length of the outer surface of the conveyance structure. The openings 3302 have a curved inner surface 3303. The arc of the curved inner surface may preferably be greater than 180 degrees, and more preferably be around 270 degrees, thereby forming lips or fingers 3306a, 3306b. In this way optical fibers, lines and other small pipe and cables may be placed or fitted into these channels as the conveyance structure is being advanced into a borehole and held in place by the fingers 3306a and 3306b. As the conveyance structure 3301 is removed from the borehole the optical fibers, lines, etc. may be stripped or pulled from the channels.

**[00223]** EXAMPLE 24

**[00224]** An embodiment of a conveyance structure is provided in FIG. 34. The conveyance structure 3401 has outer channels along the lines of example 23 which are formed by openings 3402 in its outer wall. The openings have a finger 3403 having an enlarged inner cavity 3404. In this embodiment the optical fibers, lines, small pipes etc. that are placed in the channels may be done so by forcing them in, or by slightly turning the conveyance structure to move the optical fiber etc. into the inner cavity 3404 where it will be held. The optical fibers etc. may be removed from the channel in the opposite manner from which they were inserted.

**[00225]** The tools that are useful with high power laser systems many generally be laser cutters, laser bottom hole assemblies, laser cleaners, laser monitors, laser welders and laser delivery assemblies that may have been adapted for a special use or uses. Configurations of optical elements for culminating and focusing the laser beam can be employed with these tools to provide the desired beam properties for a particular application or tool configuration. A further consideration, however, is the management of the optical affects of fluids or debris that may be located within the beam path between laser tool and the work surface.

**[00226]** In addition to directly affecting, *e.g.*, cutting, cleaning, welding, etc., a work piece or site, *e.g.*, a tubular, borehole, etc., the systems and conveyance structures can be used to transmit high power laser energy to a remote tool or location for conversion of this energy into electrical energy, for use in operating motors, sensors, cameras, or other devices associated with the tool. In this manner, for example and by

way of illustration, a single optical fiber, or one or more fibers, preferably shielded, have the ability to provide all of the energy needed to operate the remote tool, both for activities to affect the work surface, e.g., cutting drilling etc. and for other activities, e.g., cameras, motors ,etc. The optical fibers of the present invention are substantially lighter and smaller diameter than convention electrical power transmission cables; which provides a potential weight and size advantage to such high power laser tools and assemblies over conventional non-laser technologies.

**[00227]** Photo voltaic (PV) devices or mechanical devices may be used to convert the laser energy into electrical energy. Thus, as energy is transmitted down the high power optical fiber in the form high power laser energy, i.e., high power light having a very narrow wavelength distribution it can be converted to electrical, and/or mechanical energy. A photo-electric conversion device is used for this purpose and is located within, or associated with a tool or assembly. These photo-electric conversion devices can be any such device(s) that are known to the art, or may be later developed by the art, for the conversion of light energy, and in particular laser light energy, into electrical, mechanical and/or electro-mechanical energy. Thus, for example laser-driven magnetohydrodynamic (laser MHD) devices may be used, thermophotovoltaic devices may be used, thermoelectric devices may be used, photovoltaic devices may be used, a micro array antenna assembly that employs the direct coupling of photons to a micro array antenna (the term micro array antenna is used in the broadest sense possible and would include for example nano-wires, semi conducting nano-wires, micro-antennas, photonic crystals, and dendritic patterned arrays) to create oscillatory motion to then drive a current may be used, a stirling engine with the laser energy providing the heat source could be used, a steam engine or a turbine engine with the laser energy providing the heat source could be used (see, e.g., US Pat. No. 6,837,759, which uses a chemical reaction as a heat source turbine engine in an ROV, the entire disclosure of which is incorporated herein by reference). Further examples of and teachings regarding such power conversion devices are disclosed in US Patent Application Serial Number 61/446,312, the entire disclosure of which is incorporated herein by reference.

**[00228]** The present systems and conveyance structures provide the ability to have laser energy of sufficient power and characteristics to be transported over great

lengths and delivered to remote and difficult to access locations, such as found in the oil, natural gas and geothermal exploration and production. Thus, the present systems and conveyance structures may be used for drilling and workover and completions activities in the oil, natural gas and geothermal areas. These systems and structures may find use in decommissioning, plugging and abandonment activities in the oil, gas and geothermal industry, and also for off-shore structures, in the nuclear industry, in the chemical industry and in other industries. An example of another application for the present systems and conveyance structures would be in field of "flow assurance," (a broad term that has been recently used in the oil and natural gas industries to cover the assurance that hydrocarbons can be brought out of the earth and delivered to a customer, or end user). Moreover, the present systems and conveyance structures would have uses and applications beyond oil, gas, geothermal and flow assurance, and would be applicable to the, cleaning, resurfacing, removal and clearing away of unwanted materials in any location that is far removed from a laser source, or difficult to access by conventional technology as well as assembling and monitoring structures in such locations. They may also be used for the cleaning, resurfacing, removal, and clearing away of unwanted materials, e.g., build-ups, deposits, corrosion, or substances, in, on, or around structures, e.g. the work piece, or work surface area. Such unwanted materials would include by way of example rust, corrosion, corrosion by products, degraded or old paint, degraded or old coatings, paint, coatings, waxes, hydrates, microbes, residual materials, biofilms, tars, sludges, and slimes.

**[00229]** High power optical fibers that may be used with, in conjunction with, or as a high power conveyance structures would include the following Examples 25 to 34.

**[00230]** EXAMPLE 25

**[00231]** An embodiment of an optical fiber has a stainless steel metal tube, the tube having an outside diameter of about 1/8" ("inch"). The optical fiber has a core diameter of about 1000  $\mu\text{m}$ , (microns), a cladding thickness of about 50  $\mu\text{m}$ , (the thickness of a layer or coating is measured from the internal diameter or inner surface of the layer or coating to the outer diameter or outer surface of the layer or coating) and an acrylate coating thickness of about 100  $\mu\text{m}$ .

**[00232]** EXAMPLE 26

**[00233]** An embodiment of an optical fiber has a core diameter of about 600  $\mu\text{m}$ , (microns), a cladding thickness of about 30  $\mu\text{m}$ , and an acrylate coating thickness of about 75  $\mu\text{m}$ . The optical fiber cable may be an optical fiber with any added outer protective layers.

**[00234]** EXAMPLE 27

**[00235]** An embodiment of an optical fiber has a core of about 1000  $\mu\text{m}$ , (microns), a cladding having a thickness of about 50  $\mu\text{m}$ , and an acrylate coating having a thickness of about 100  $\mu\text{m}$ .

**[00236]** EXAMPLE 28

**[00237]** An embodiment of a multi-clad fiber has: a core 1303, having a diameter of about 600  $\mu\text{m}$  and an NA of about 0.2; a first cladding 1305 (which is adjacent the core) having an outer diameter of about 645  $\mu\text{m}$  and an NA of 0.24; a second cladding 1307 (which is adjacent the first cladding) and having an outer diameter of about 660  $\mu\text{m}$  and an NA of 0.35; a layer of silicone (which is adjacent to the second cladding) and having an outer diameter of about 685  $\mu\text{m}$ ; and, an layer of acrylate (which is adjacent the silicone layer) and having an outer diameter of about 810  $\mu\text{m}$ .

**[00238]** EXAMPLE 29

**[00239]** Double-clad and Multi-clad fiber optics may be utilized and prove beneficial to particular applications and in particular when the distal end is optically associated with a connector, such as the connectors provided in US Patent Application serial number 61/493,174, the entire disclosure of which is incorporated herein by reference. A double-clad fiber may reduce or eliminate the need for mode stripping or may be used to augment the ability to manage back reflections in association with a connector. Additionally, a fiber that can propagate cladding modes has the advantage of affording flexibility around the location of mode stripping should it be preferred. The thickness of the outer clad may be chosen so as to minimize the probability of back reflections coupling into it. In these embodiments, the NA of the fiber core may, for example, be between about .06 and .48, with index of refraction between about 1.4 and 2, for wavelengths between about 200 nm and 15  $\mu\text{m}$ . The NA of the first clad, if present, may be between about 0 (and more preferably .01) and .48, with index of

refraction between about 1.4 and 2, for wavelengths between about 200 nm and 15  $\mu\text{m}$ . The NA of the second clad, if present, may be between about 0 (and more preferably .01) and .48, with index of refraction between about 1.4 and 2, for wavelengths between about 200 nm and 15  $\mu\text{m}$ . The NA of further clads, if present, may be between about 0 (and more preferably .01) and .48, with index of refraction between about 1.4 and 2, for wavelengths between about 200 nm and 15  $\mu\text{m}$ . The index of refraction of the buffer, if present, may be between about 1.4 and 2, for wavelengths between about 200 nm and 15  $\mu\text{m}$ . Combinations of single, double, and multi-clad fibers may also be used.

**[00240]** EXAMPLE 30

**[00241]** An embodiment of an optical fiber has a core, first clad, second clad, silicone buffer, and Teflon-style coating. The core having an NA of about 0.2, and an index of about 1.450 at the wavelength of 1070 nm. The first clad having an NA of about 0.23, and an index of about 1.436 at the wavelength of 1070 nm. The second clad having an NA of about 0.35, and an index of about 1.417 at the wavelength of 1070 nm. The silicone having an index of about 1.373 at the wavelength of 1070 nm.

**[00242]** EXAMPLE 31

**[00243]** An embodiment of an optical fiber has a core, first clad, and acrylate-style coating. The core having an NA of about 0.2, and an index of about 1.45 at the wavelength of 1070 nm. The first clad having an index of about 1.436 at the wavelength of 1070 nm.

**[00244]** EXAMPLE 32

**[00245]** An embodiment of an optical fiber has a core, first clad, second clad, and Polyimide-style coating. The core having an NA of about 0.1, and an index of about 1.45 at the wavelength of 1070 nm. The first clad having an NA of about 0.12, and an index of about 1.447 at the wavelength of 1070 nm. The second clad having an NA of about 0.2, and an index of about 1.442 at the wavelength of 1070 nm. The polyimide having an index of about 1.428 at the wavelength of 1070 nm.

**[00246]** EXAMPLE 33

**[00247]** An embodiment of an optical has a core, first clad, and acrylate-style coating. The core having an NA of about 0.2, and an index of about 1.5 at the

wavelength of 2000 nm. The first clad having an index of about 1.487 at the wavelength of 2000 nm.

**[00248]** EXAMPLE 34

**[00249]** An embodiment of an optical fiber has a core, first clad, second clad, silicone buffer, and Teflon-style coating. The core having an NA of about 0.2, and an index of about 1.450 at the wavelength of 1070 nm. The first clad having an NA of about 0, and an index of about 1.436 at the wavelength of 1070 nm. The second clad having an NA of about 0.35, and an index of about 1.450 at the wavelength of 1070 nm. The silicone having an index of about 1.407 at the wavelength of 1070 nm.

**[00250]** In addition to step index fibers, for example of the types provided in Examples 30 to 34, other step index configurations may be utilized. Additionally, fibers of other configurations, shapes and types may be utilized, such as for example fibers with air clads, polymer clads, or graded index fibers.

**[00251]** Additionally, the buffer or jacket coating may preferably be tefzel, teflon, or another fluoropolymer or similar material which has significant transmission at the desired wavelength, and substantial temperature capability for the selected application.

**[00252]** The various embodiments of conveyance structures set forth in this specification may be used with the various high power laser systems set forth in this specification. The various embodiments of conveyance structures set forth in this specification may be used with other high power laser systems that may be developed in the future, or with existing non-high power laser systems, which may be modified in-part based on the teachings of this specification, to create a laser system. The various embodiments of high power laser systems may also be used with other conveyance structures that may be developed in the future, or with existing structures, which may be modified in-part based on the teachings of this specification to provide for the transmission of high power laser energy. Further the various handling apparatus, optical fibers, and other equipment set forth in this specification may be used with the various conveyance structures, high power laser systems, and combinations and variations of these, as well as, future structures and systems, and modifications to existing structures and systems based in-part upon the teachings of this specification.



Thus, for example, the structures, fibers, equipment, apparatus, and systems provided in the various Figures and Examples of this specification may be used with each other and the scope of protection afforded the present inventions should not be limited to a particular embodiment, configuration or arrangement that is set forth in a particular embodiment in a particular Figure.

**[00253]** Many other uses for the present inventions may be developed or released and thus the scope of the present inventions is not limited to the foregoing examples of uses and applications. The present inventions may be embodied in other forms than those specifically disclosed herein without departing from their spirit or essential characteristics. The described embodiments are to be considered in all respects only as illustrative and not restrictive.

What is claimed:

1. A mobile high power laser system comprising: a laser cabin, the laser cabin housing a high power laser system having the capability to generate a laser beam having at least about 10 kW of power and a wavelength in the range of about 800 nm to about 2100 nm; a conveyance structure having a length of at least about 3,000 feet; the conveyance structure comprising: a high power optical fiber having a core diameter of at least about 500  $\mu\text{m}$  and a length of at least about 3,000 ft, a first support structure having a length of at least about 3,000 feet, a second support structure having a length of at least about 3,000 feet, a data or control line having a length of at least about 3,000 feet, and a passage defined by the first or second support structure, the passage having a length of at least about 3,000 feet; and a means for handling the conveyance structure.
2. The mobile high power laser system of claim 1, wherein the means for handling comprises an injector.
3. The mobile high power laser system of claim 1, wherein the means for handling comprises a spool and an optical slip ring.
4. The mobile high power laser system of claim 2, comprising a second passage and wherein the line provides electric power.
5. The mobile high power laser system of claim 1, comprising an optical block.
6. A mobile high power laser system comprising: a laser cabin, the laser cabin housing a high power laser having the capability to generate a laser beam having at least about 10 kW of power; a conveyance structure having a length of at least about 4,000 feet; the conveyance structure comprising: a high power optical fiber having a core diameter of at least about 300  $\mu\text{m}$  and a length of at least about 4,000 feet, an outer support structure having a length of at least about 4,000 feet, an inner support structure having a length of at least about 4,000 feet, a data or control line having a length of at least about 4,000 feet, and a passage defined by the inner or the outer support structure,

- the passage having a length of at least about 4,000 feet; and a means for handling the conveyance structure.
7. The mobile laser system of claim 6, wherein the lengths of the optical fiber, the outer support structure, the inner support structure, the line, and the passage are at least about 5,000 feet.
  8. The mobile laser system of claim 6, wherein the lengths of the optical fiber, the outer support structure, the inner support structure, the line, and the passage are at least about 10,000 feet.
  9. The mobile high power laser system of claim 6, wherein the means for handling comprises an injector.
  10. The mobile high power laser system of claim 6, wherein the means for handling comprises a spool and an optical slip ring.
  11. The mobile high power laser system of claim 6, comprising a second passage and wherein the line provides electric power.
  12. The mobile high power laser system of claim 6, comprising an optical block.
  13. A mobile high power laser system comprising:
    - a. a base;
    - b. a means for providing a high power laser beam having at least 5 kW of power;
    - c. a means for containing a handling apparatus;
    - d. an operator station; and,
    - e. a means for providing electrical power.
  14. The mobile high power system of claim 13, wherein the base comprises a truck chassis; wherein the means for providing the high power laser beam comprises a mobile laser room and wherein the mobile laser room is mounted to the truck chassis; wherein the means for containing the handling apparatus comprises a handling apparatus cabin or a handling apparatus bay and

comprises a handling apparatus comprising at least about 4,000 feet of a high power conveyance structure; and wherein the operator station is controllably associated with the mobile laser room and the handling apparatus.

15. The mobile high power system of claim 13, wherein the base comprises a trailer; wherein the means for providing the high power laser beam comprises a mobile laser room; wherein the means for containing the handling apparatus comprises a handling apparatus cabin or a handling apparatus bay, and comprises a handling apparatus comprising at least about 4,000 feet of a high power conveyance structure and is mounted to the trailer; and wherein the operator booth is controllably associated with the mobile laser room and the handling apparatus.
16. A mobile high power laser system comprising:
  - a. a laser housing;
  - b. a handling apparatus;
  - c. a high power laser capable of generating at least a 10 kW laser beam within the laser housing;
  - d. a conveyance structure comprising a high power optical fiber, a passage, a line and a support structure, wherein the high power optical fiber having a core diameter of at least about 300  $\mu\text{m}$  and a minimum bend radius; and,
  - e. an optical block having a radius of curvature, wherein the optical block radius of curvature is greater than, equal to, or within 5% less than the radius of curvature of the high power optical fiber.
17. The mobile high power laser system of claim 16, comprising at least 5,000 feet of conveyance structure and wherein the core diameter is at least about 450  $\mu\text{m}$ .
18. The mobile high power laser system of claim 17, wherein the high power laser is capable of generating a laser beam of at least 20 kW.

19. The mobile high power laser system of claim 16, wherein the laser housing and the handling apparatus are associated with a platform.
20. The mobile high power laser system of claim 16, wherein the laser housing is associated with a first mobile base and the handling apparatus is associated with a second mobile base.

1/29

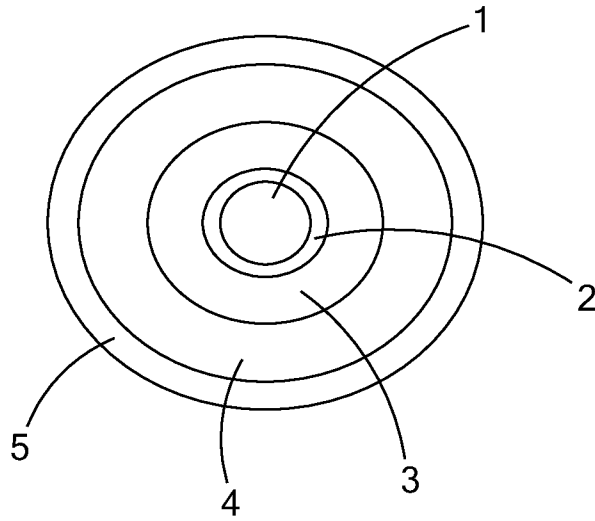

Fig. 1A

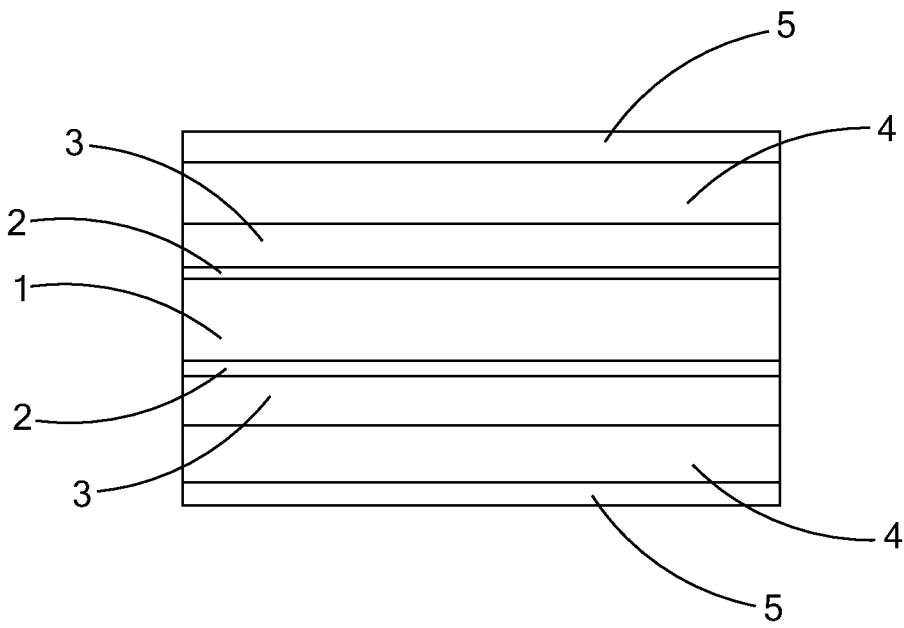

Fig. 1B

2/29

λ Mkr A: 1069.28nm      B: 1070.61nm      B-A: 1.33nm  
 LMkr C: -68.61dBm      D: -71.61dBm      C-D: 3.0dB

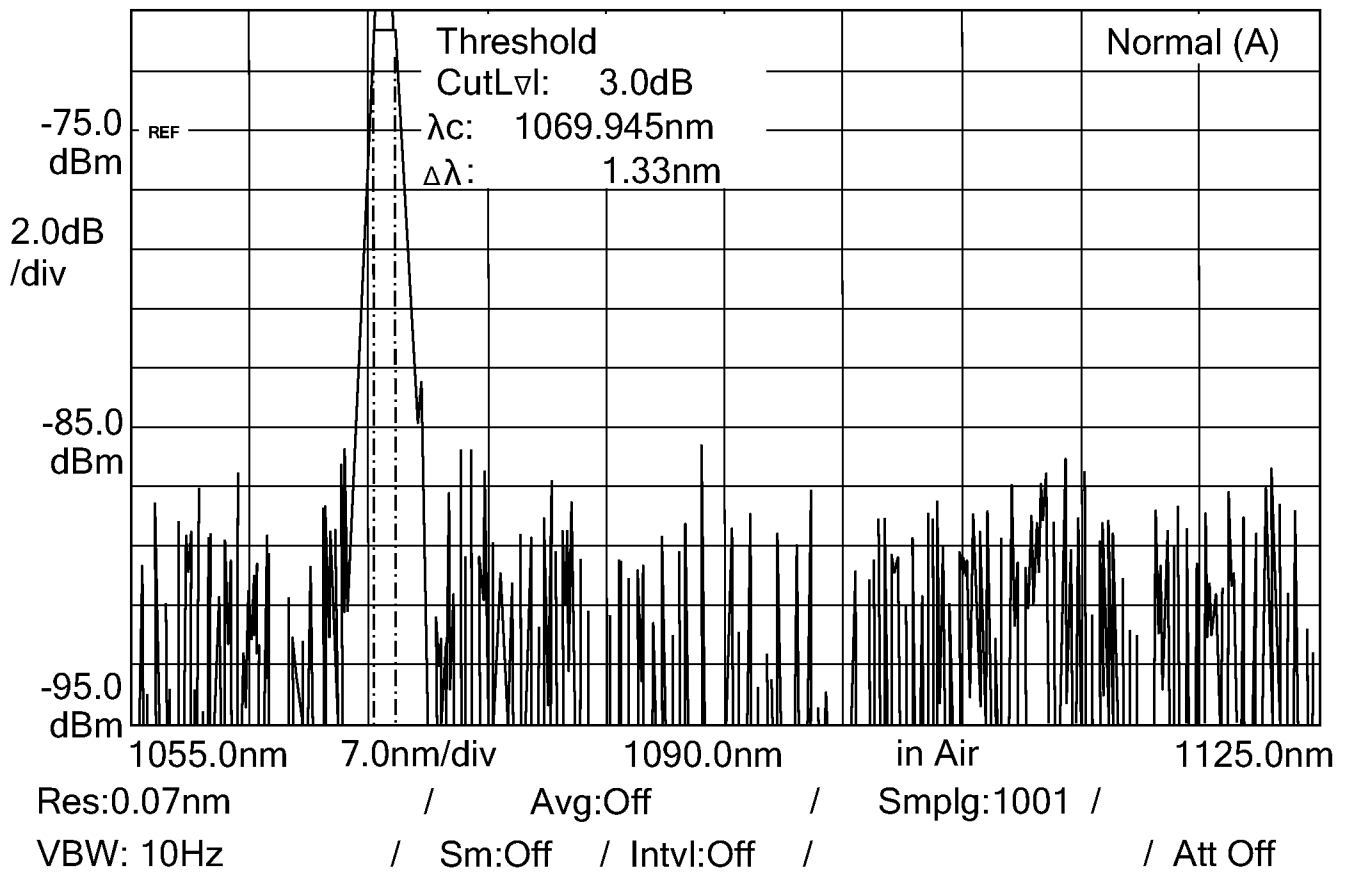

Fig. 2

3/29

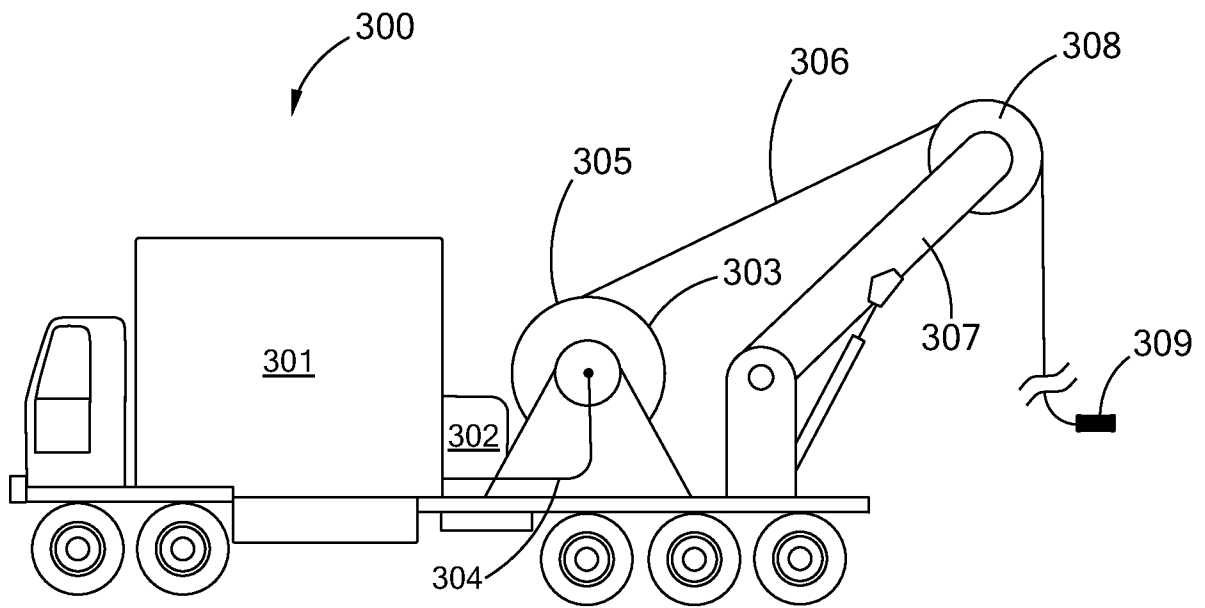

Fig. 3



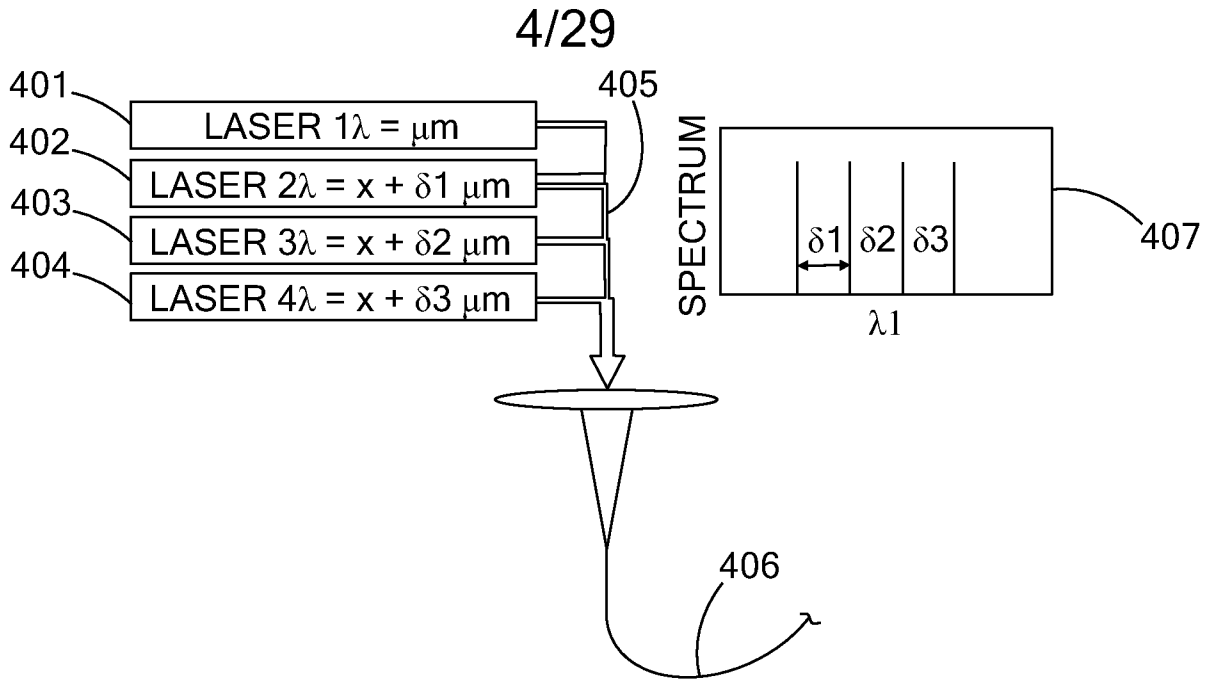

Fig. 4

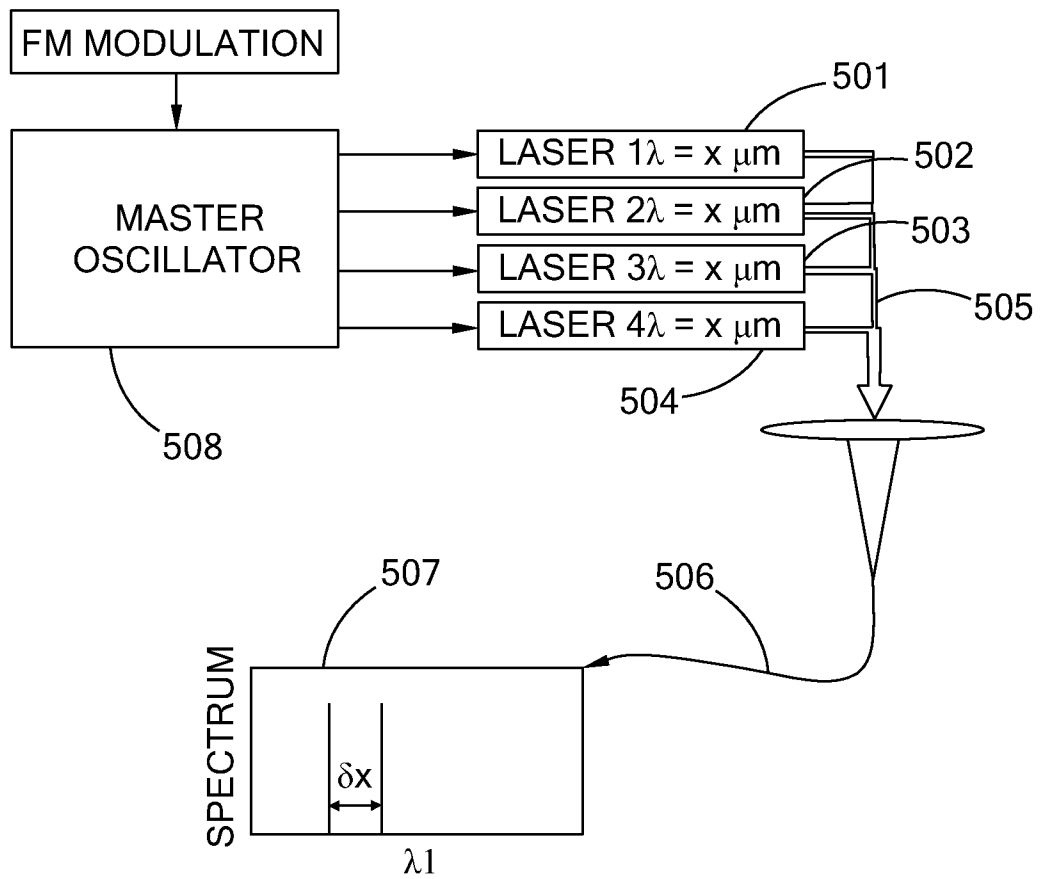

Fig. 5

5/29

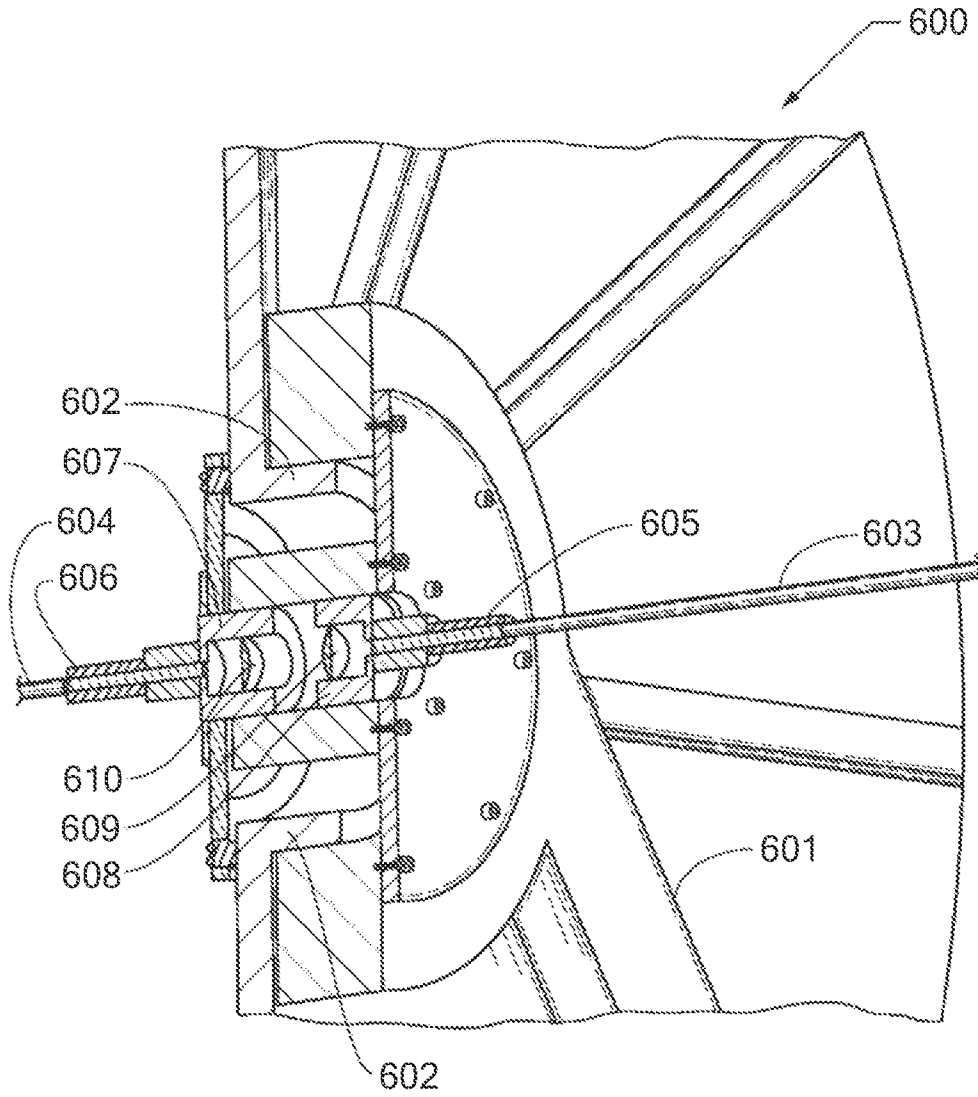

Fig. 6

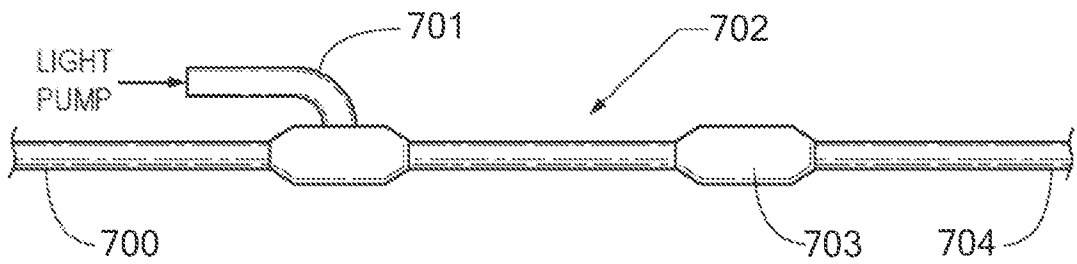

Fig. 7

6/29

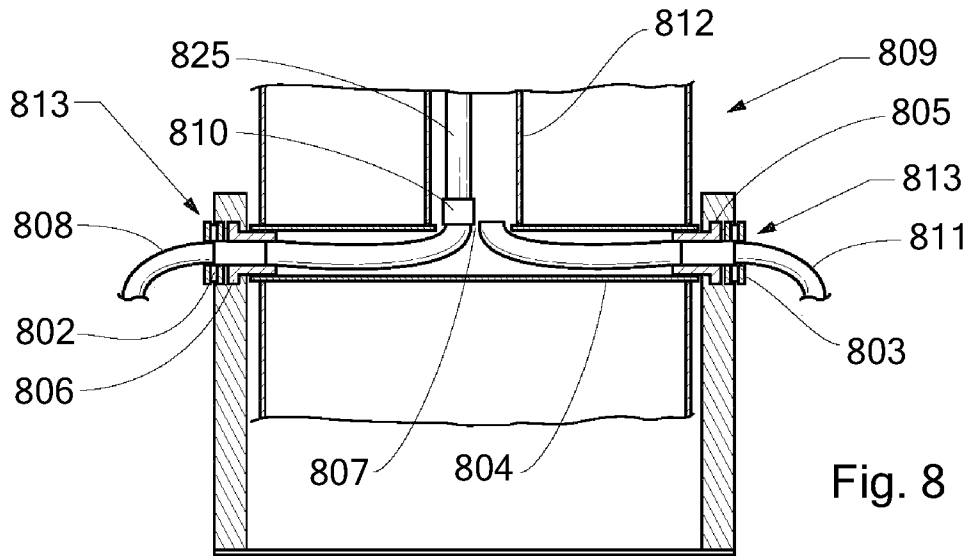

Fig. 8

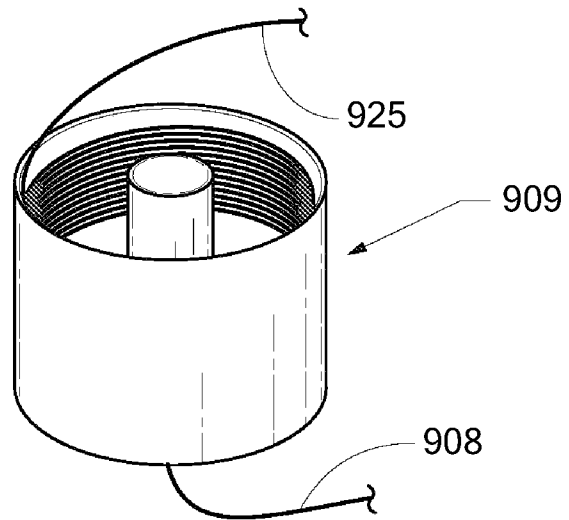

Fig. 9A

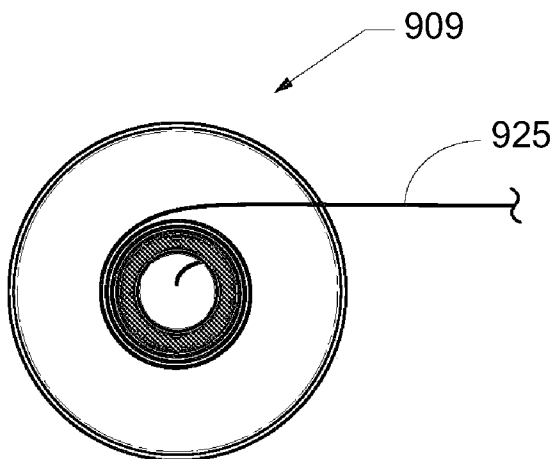

Fig. 9B

7/29

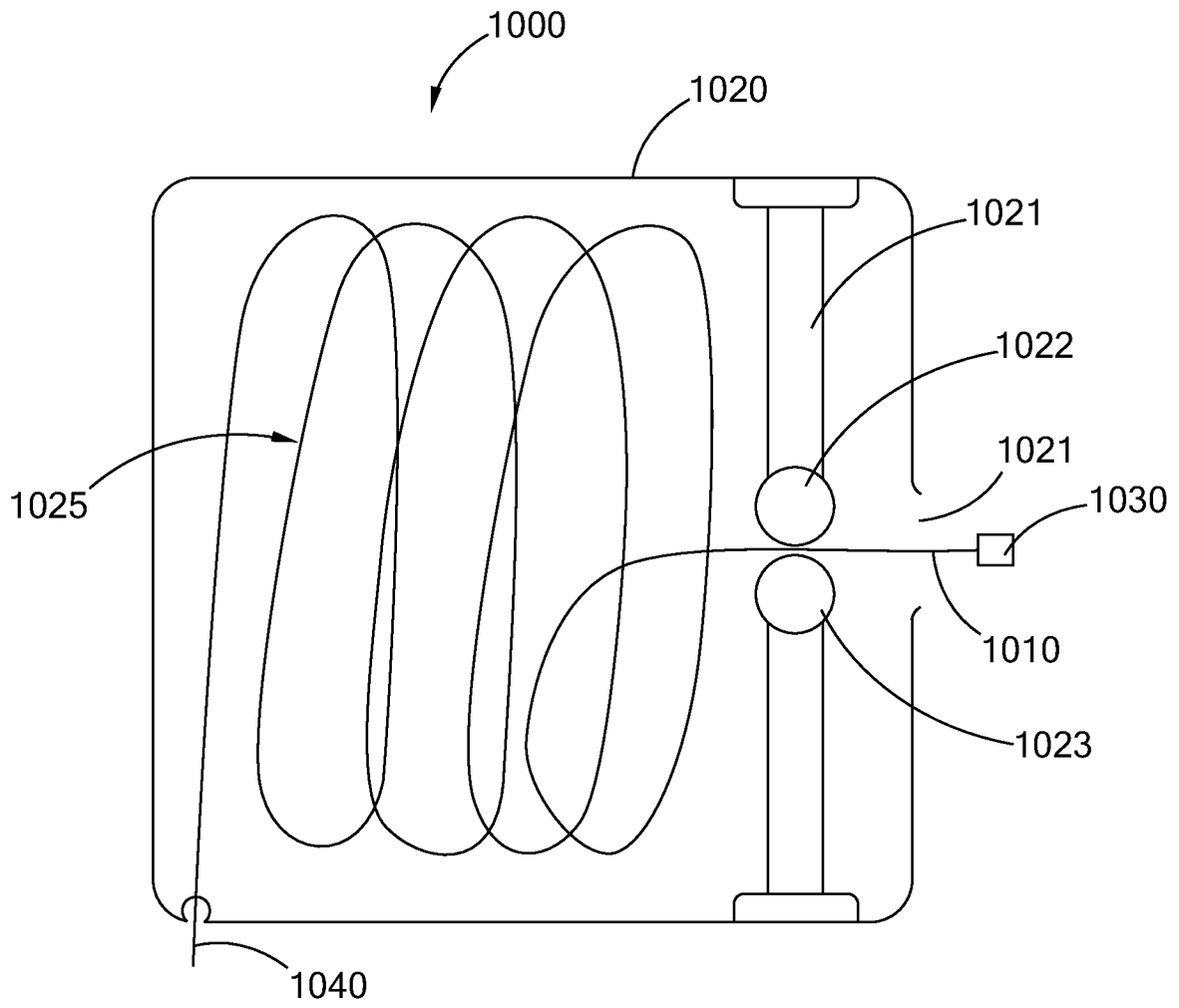

Fig. 10

8/29

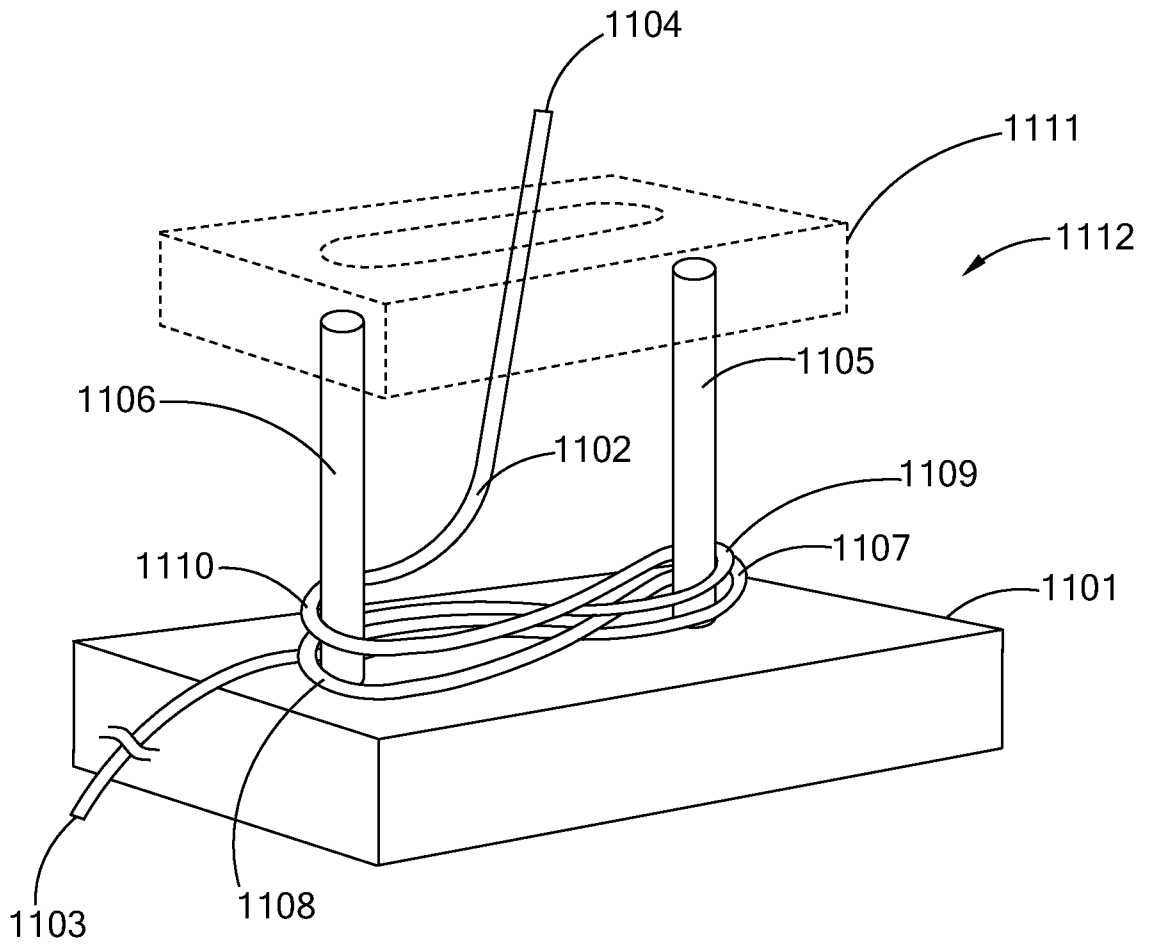

Fig. 11

9/29

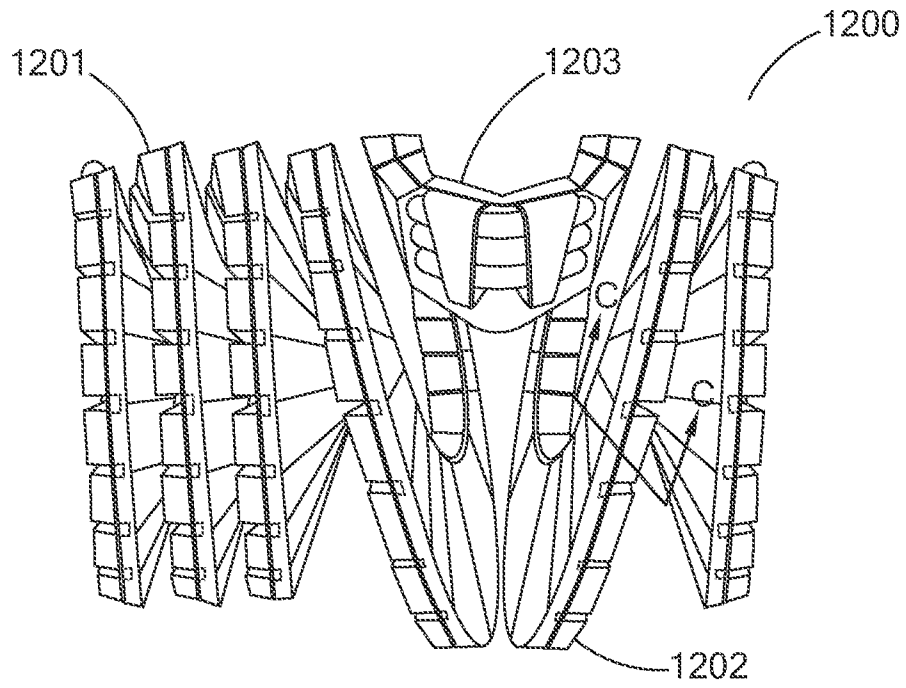

Fig. 12A

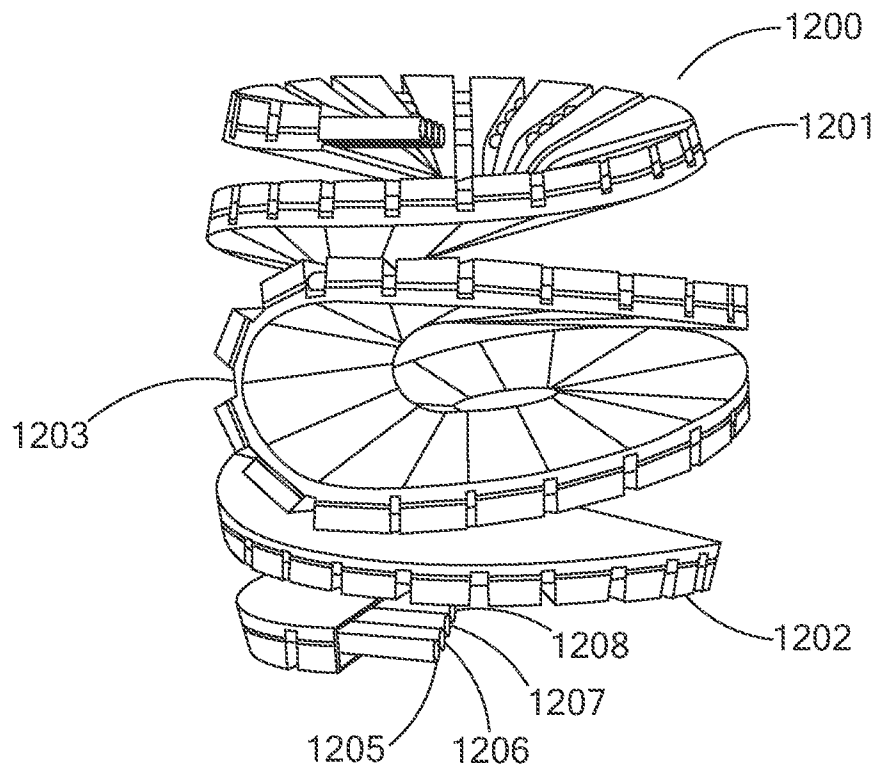

Fig. 12B

10/29

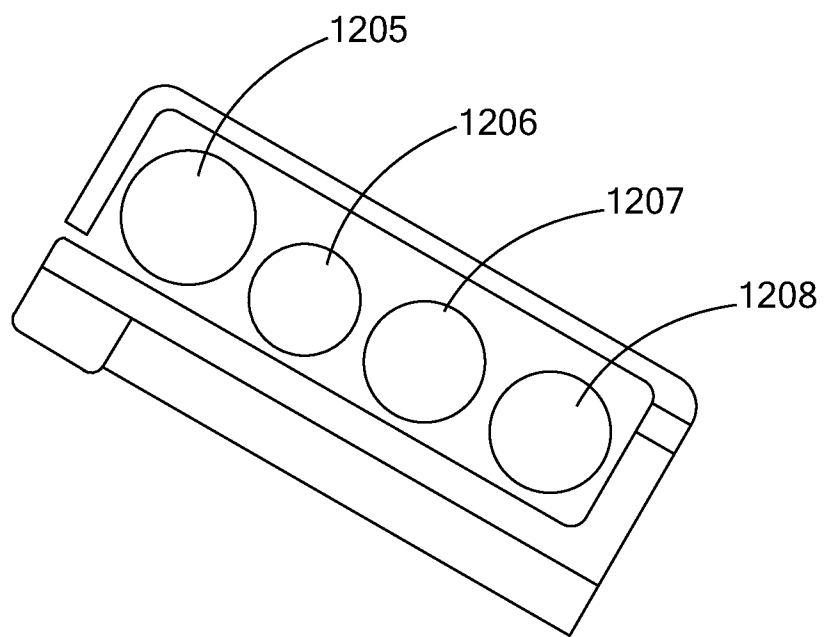

Fig. 12C

11/29

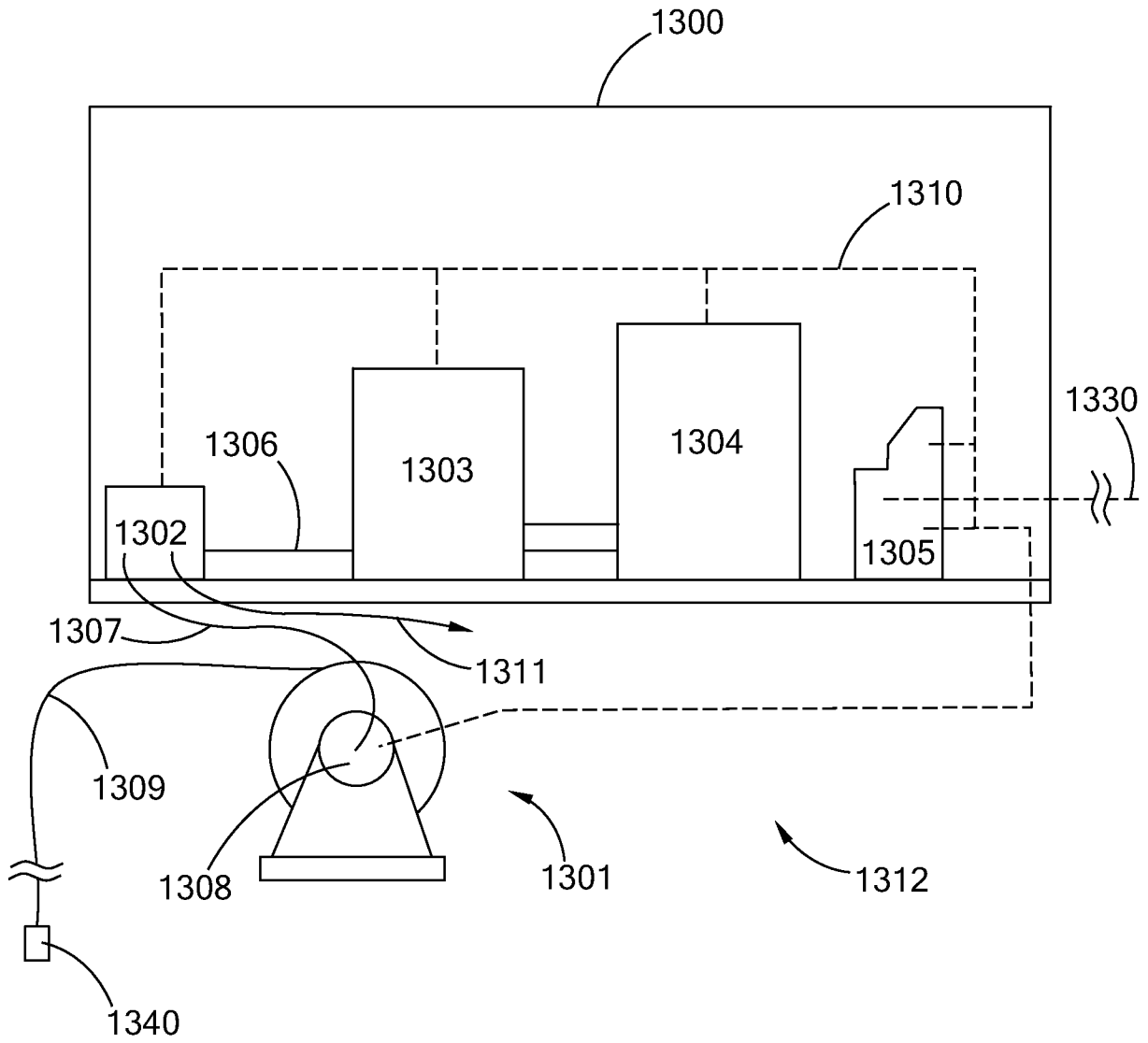

Fig. 13



12/29

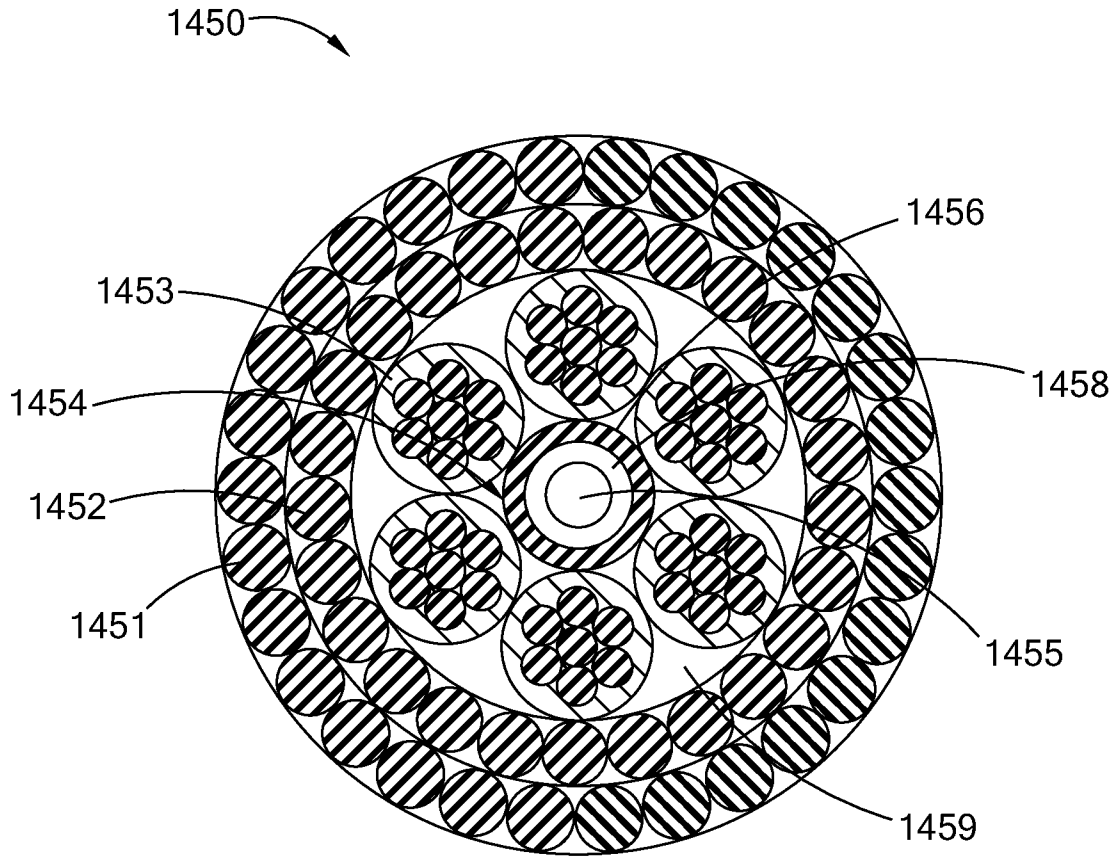

Fig. 14

13/29

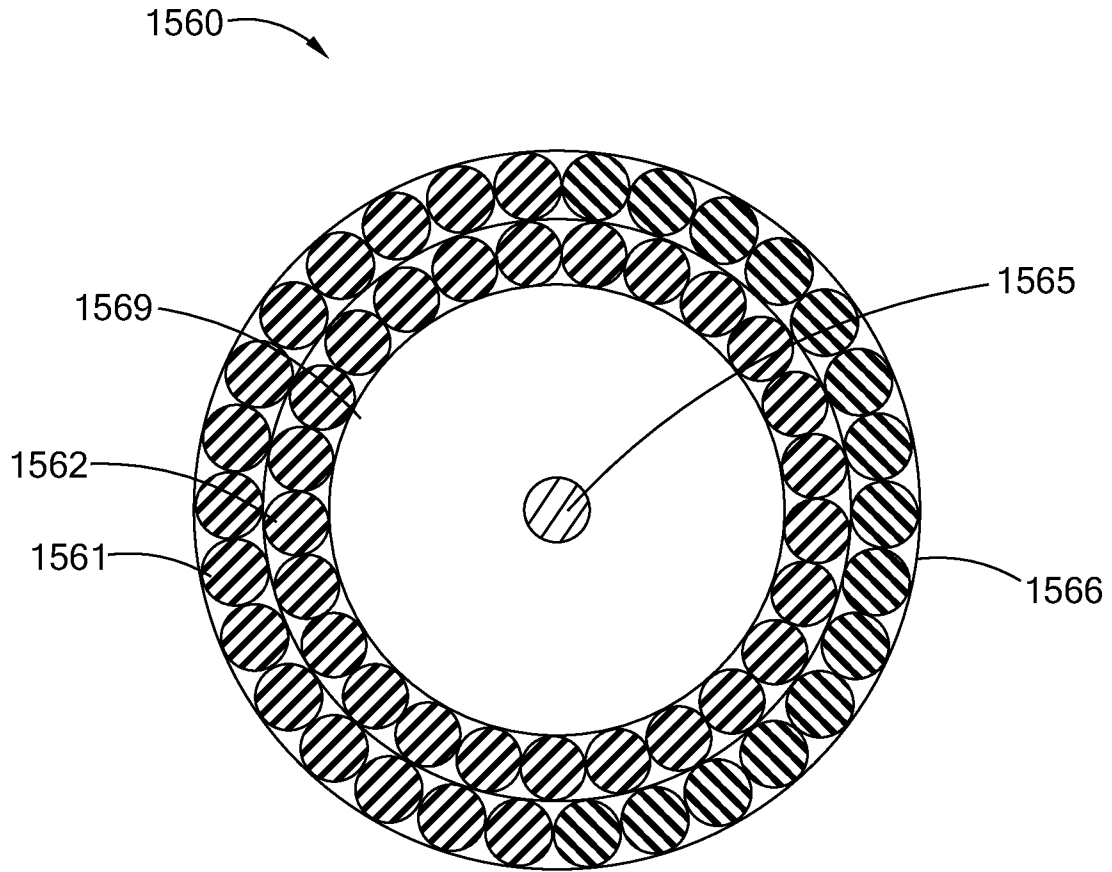

Fig. 15

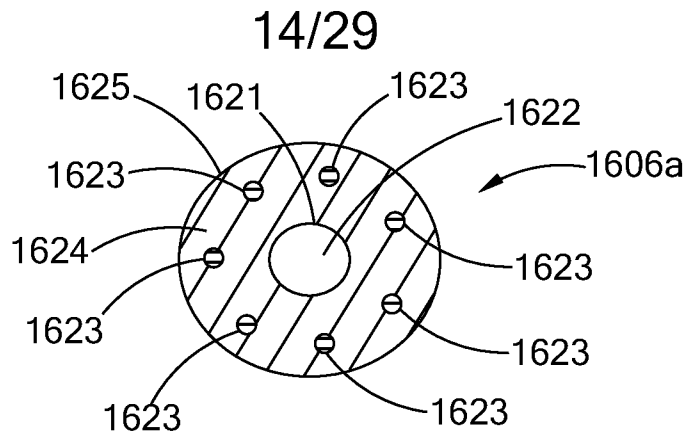

Fig. 16

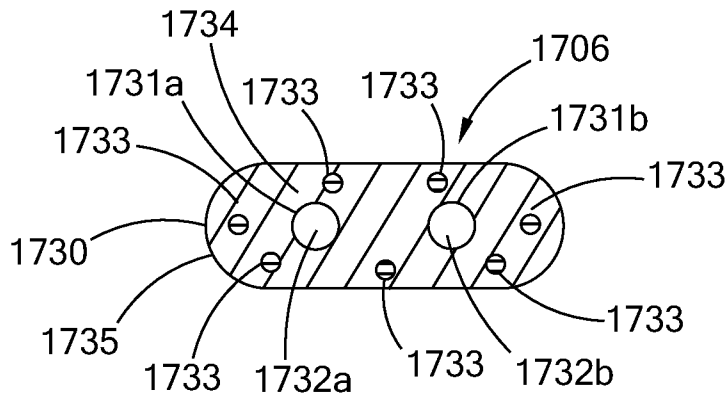

Fig. 17

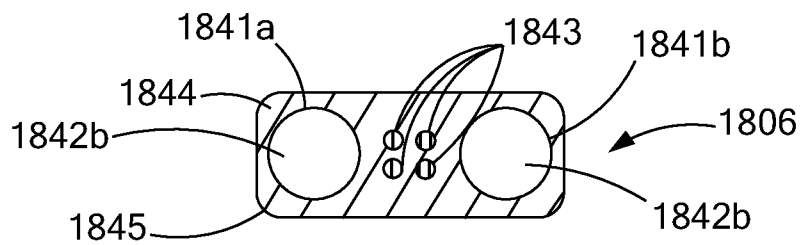

Fig. 18

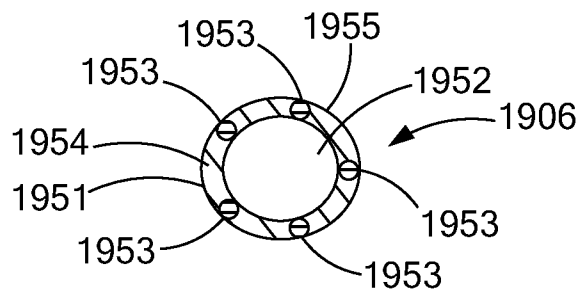

Fig. 19

15/29

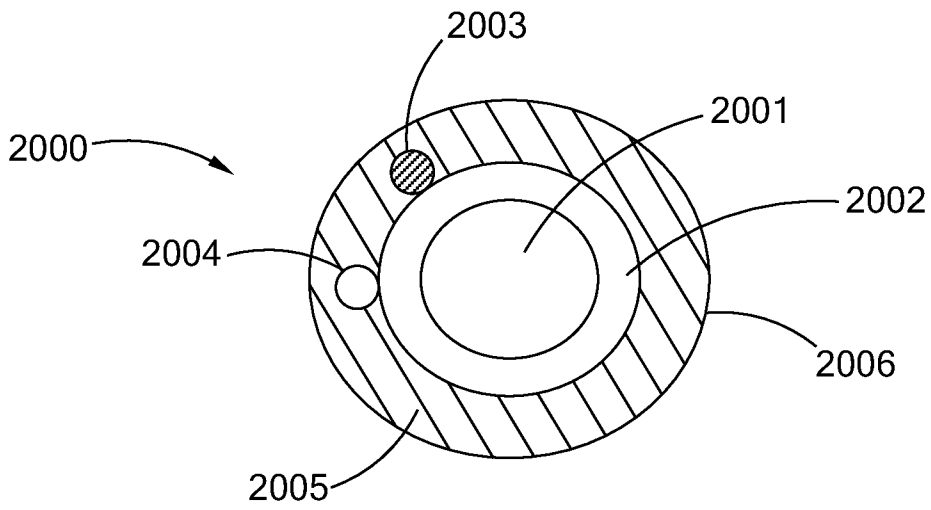

Fig. 20A

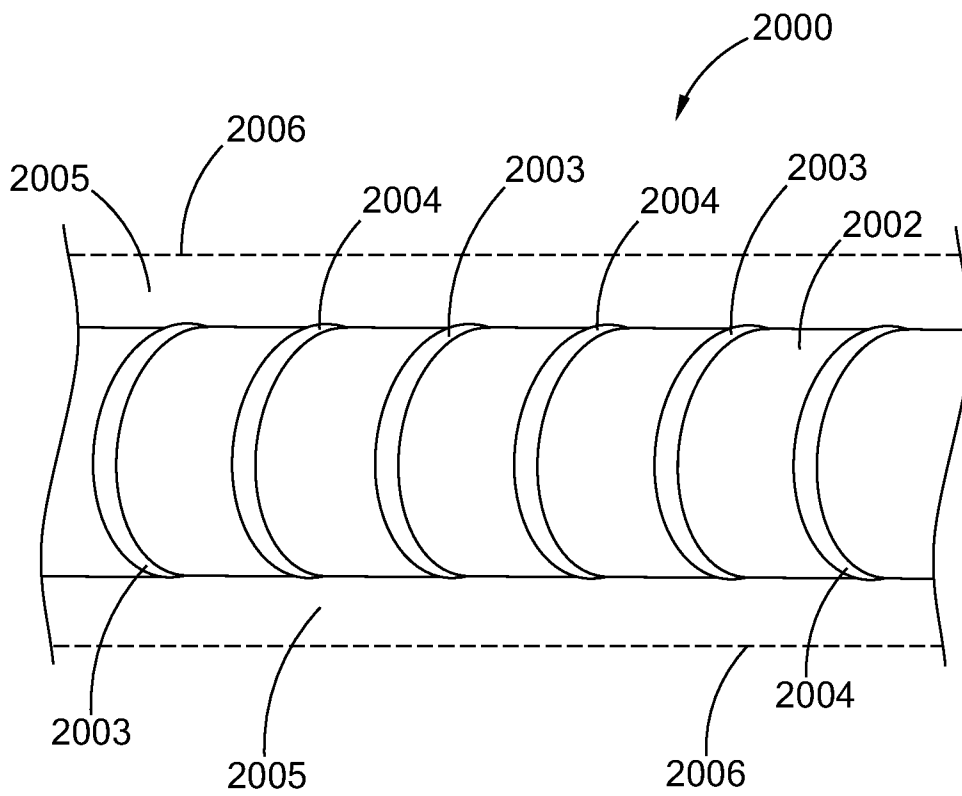

Fig. 20B

16/29

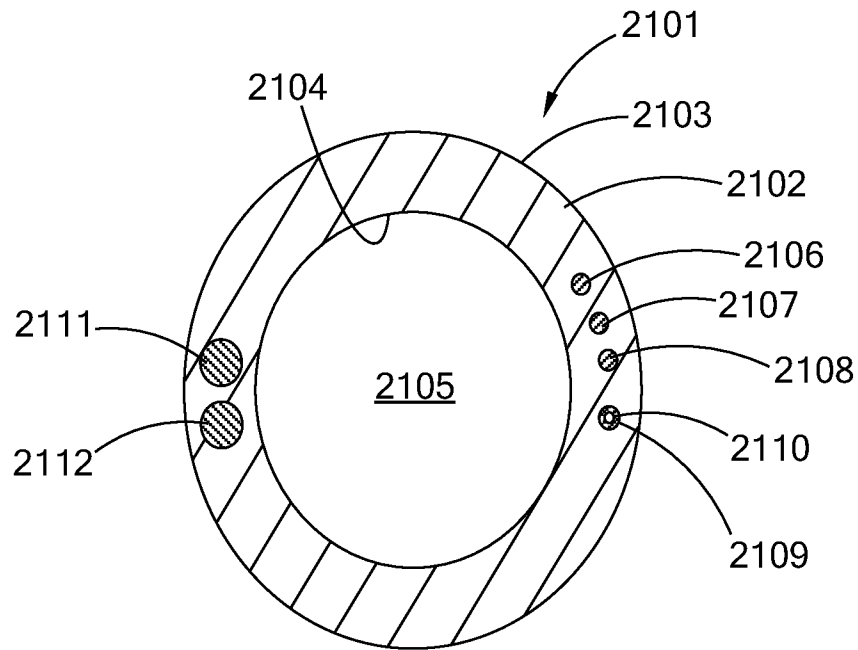

Fig. 21

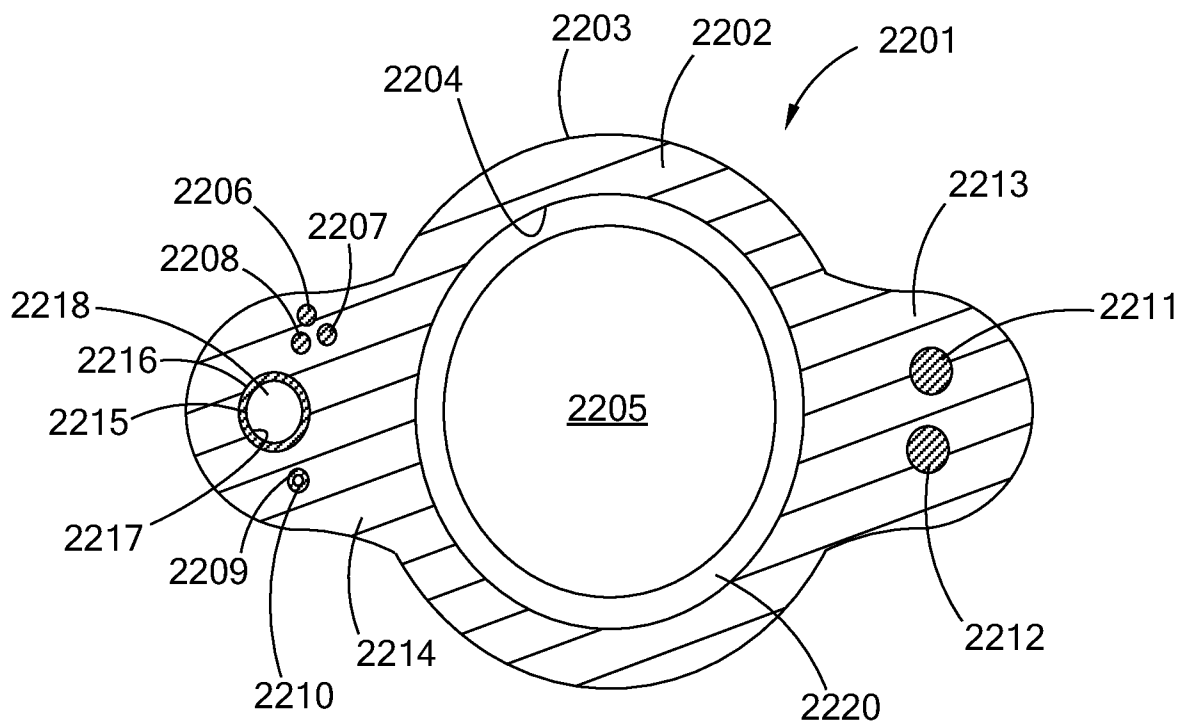

Fig. 22

17/29

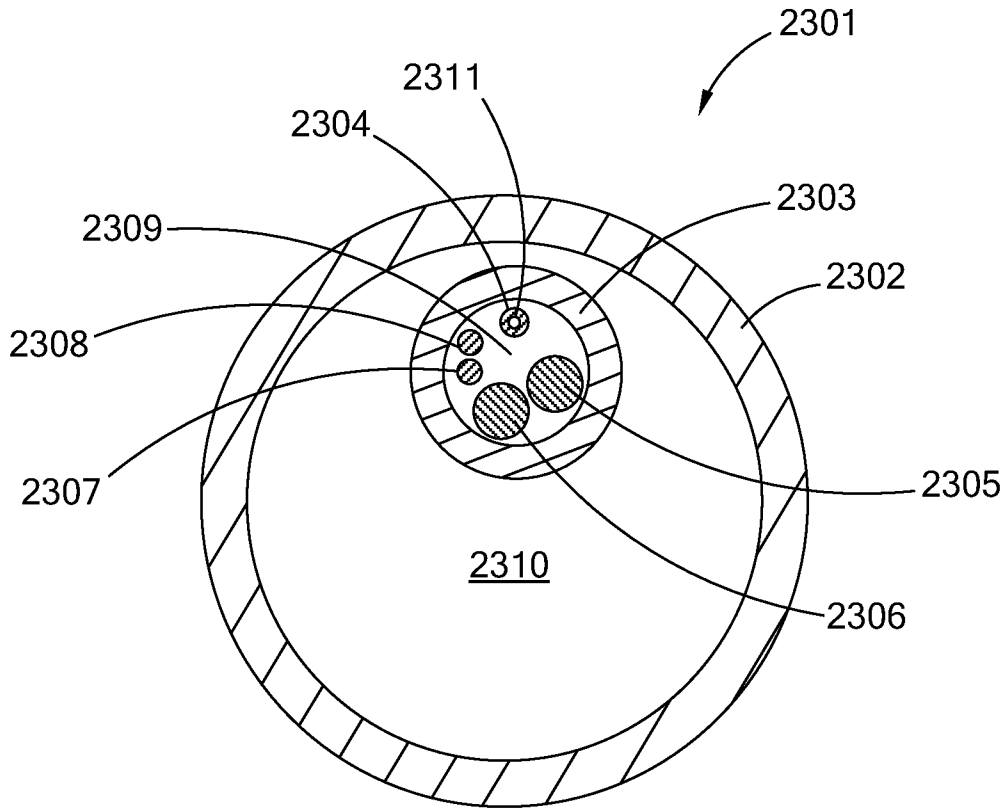

Fig. 23

18/29

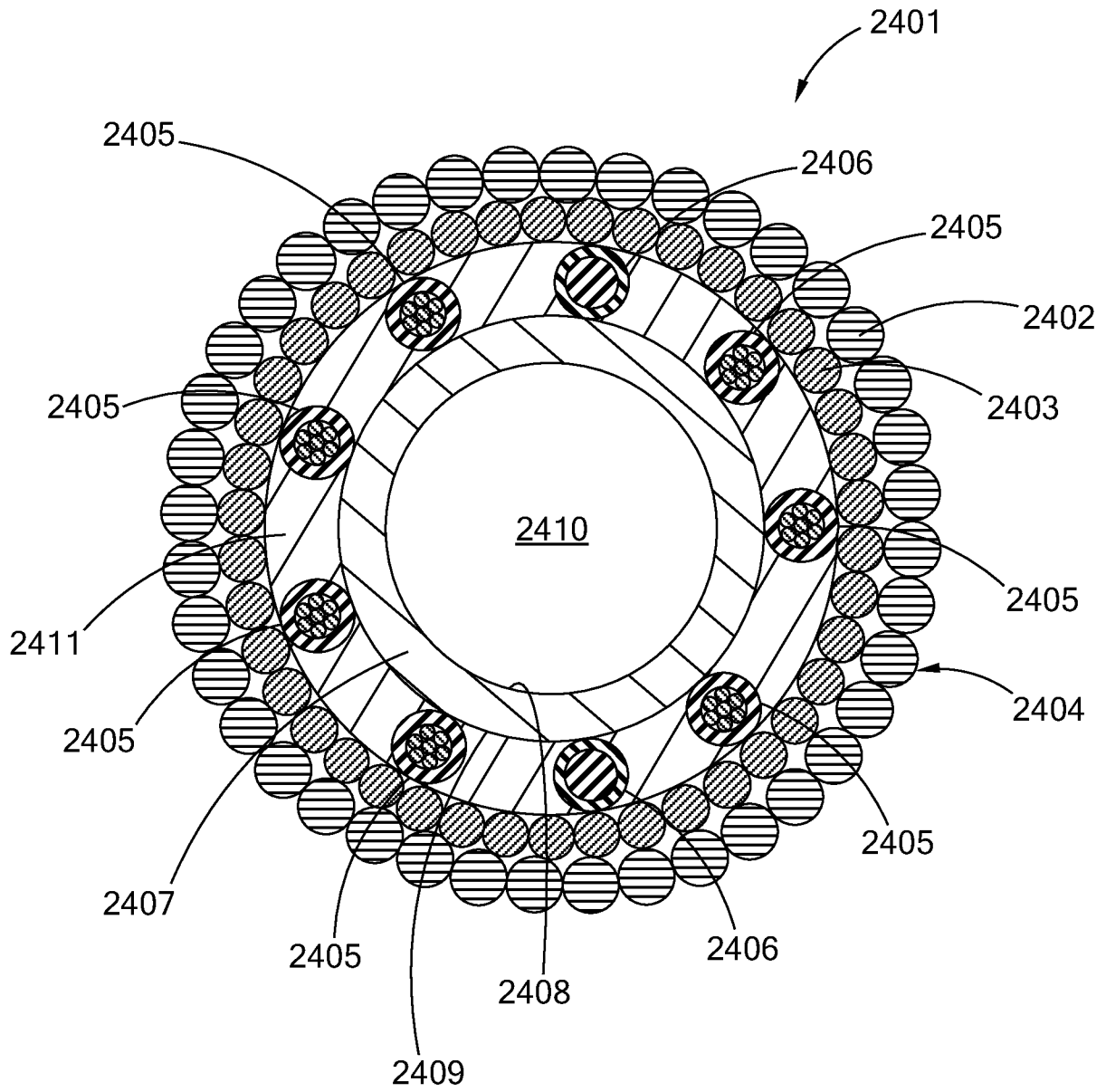

Fig. 24

19/29

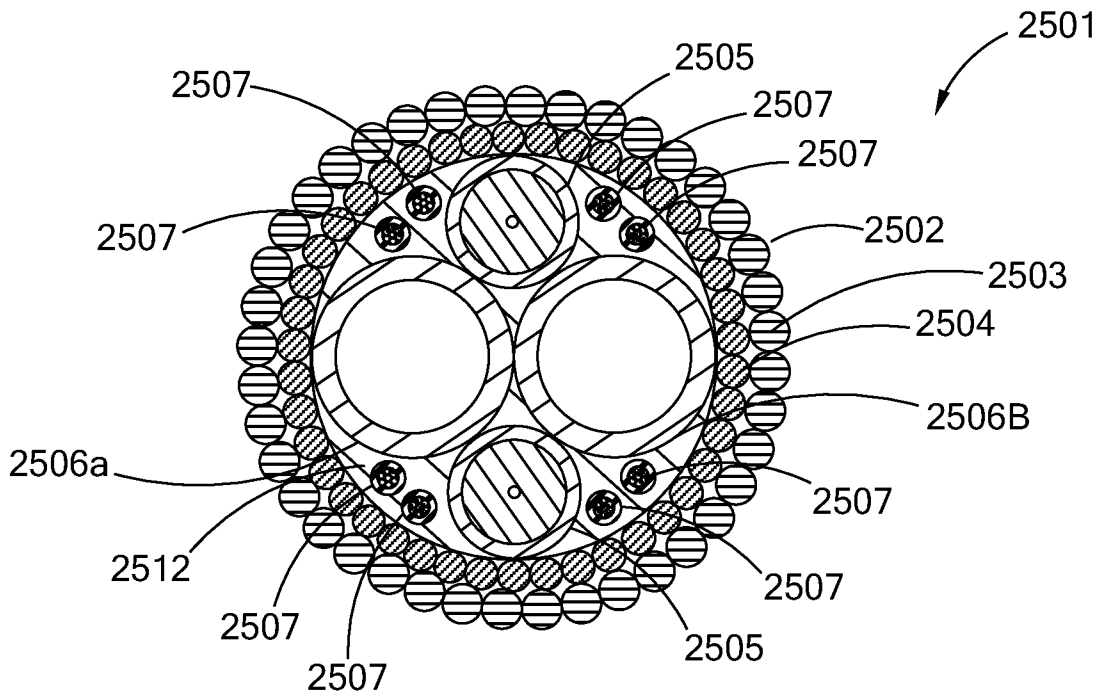

Fig. 25

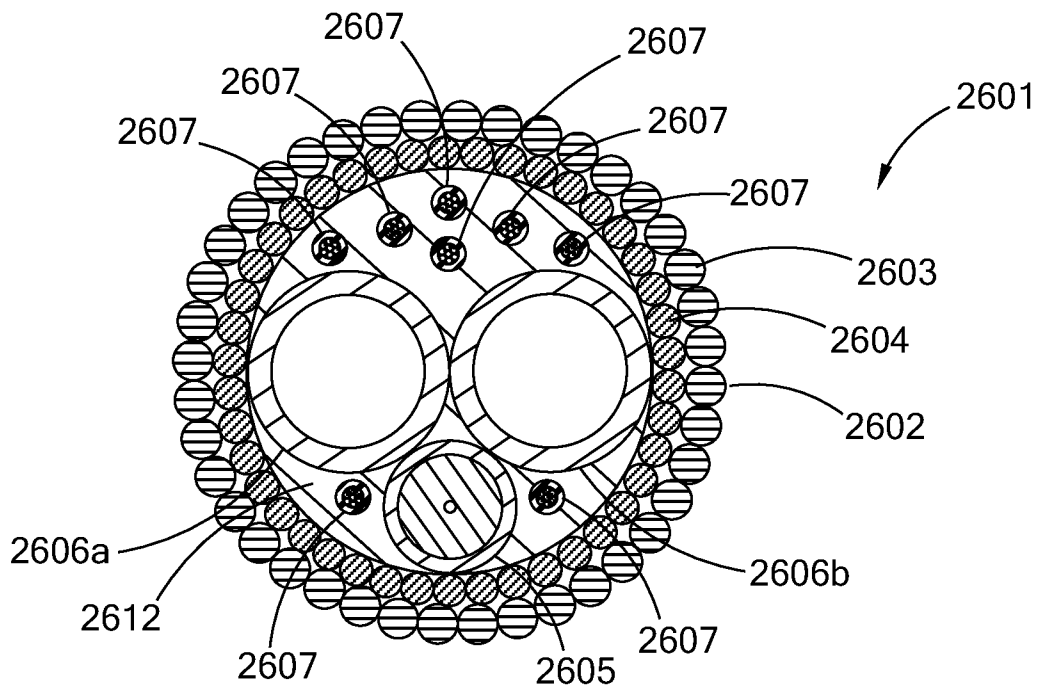

Fig. 26



20/29

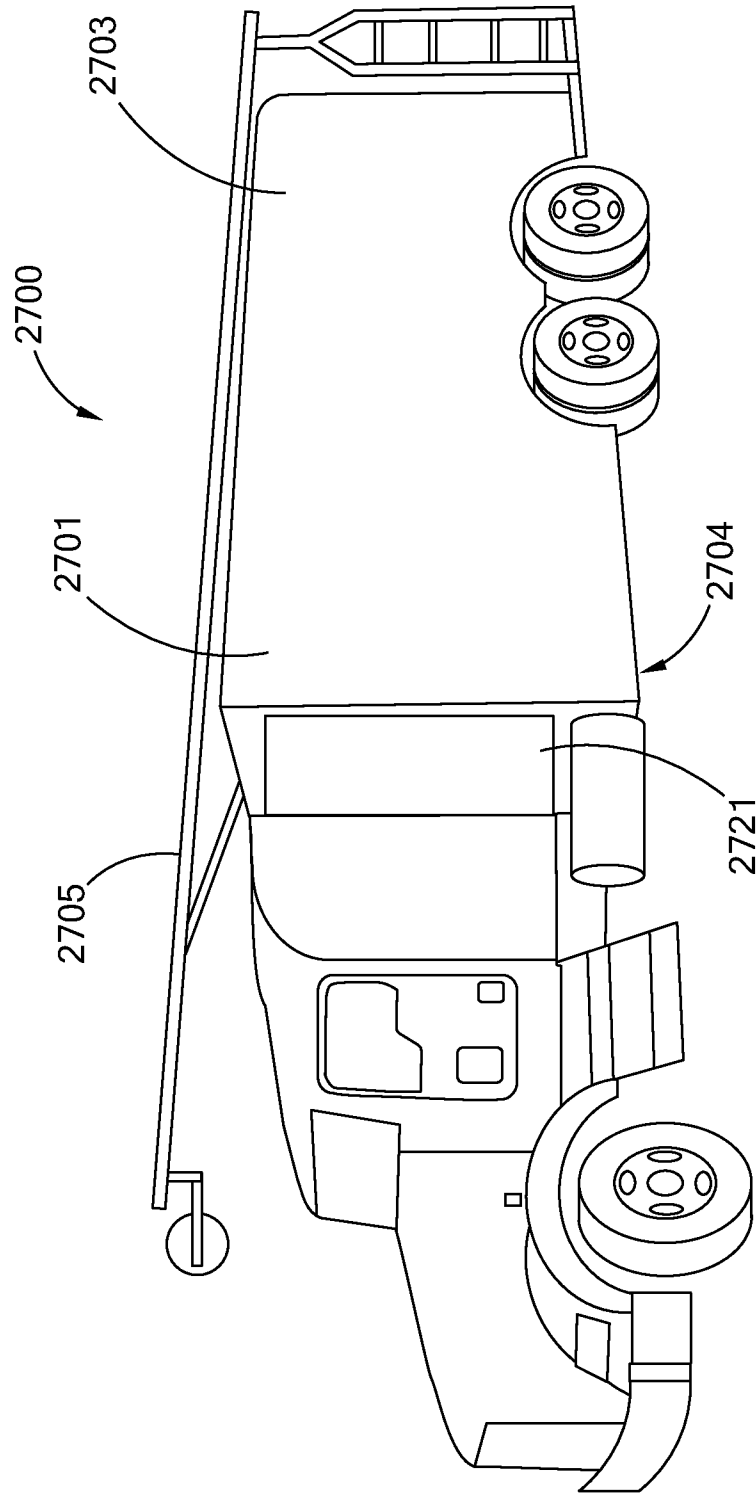

Fig. 27A

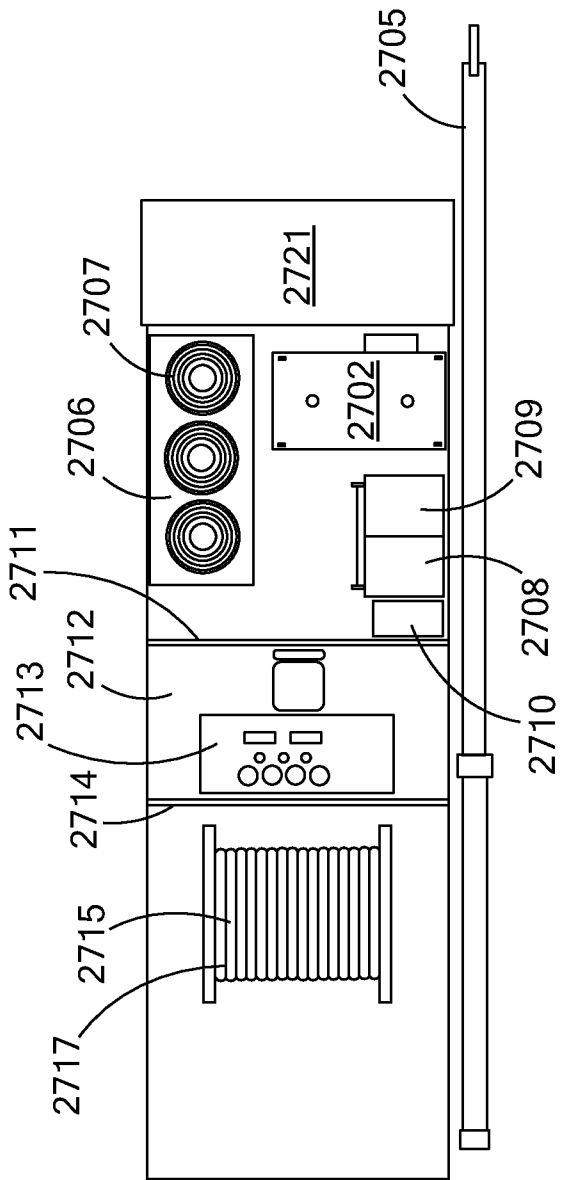

Fig. 27B

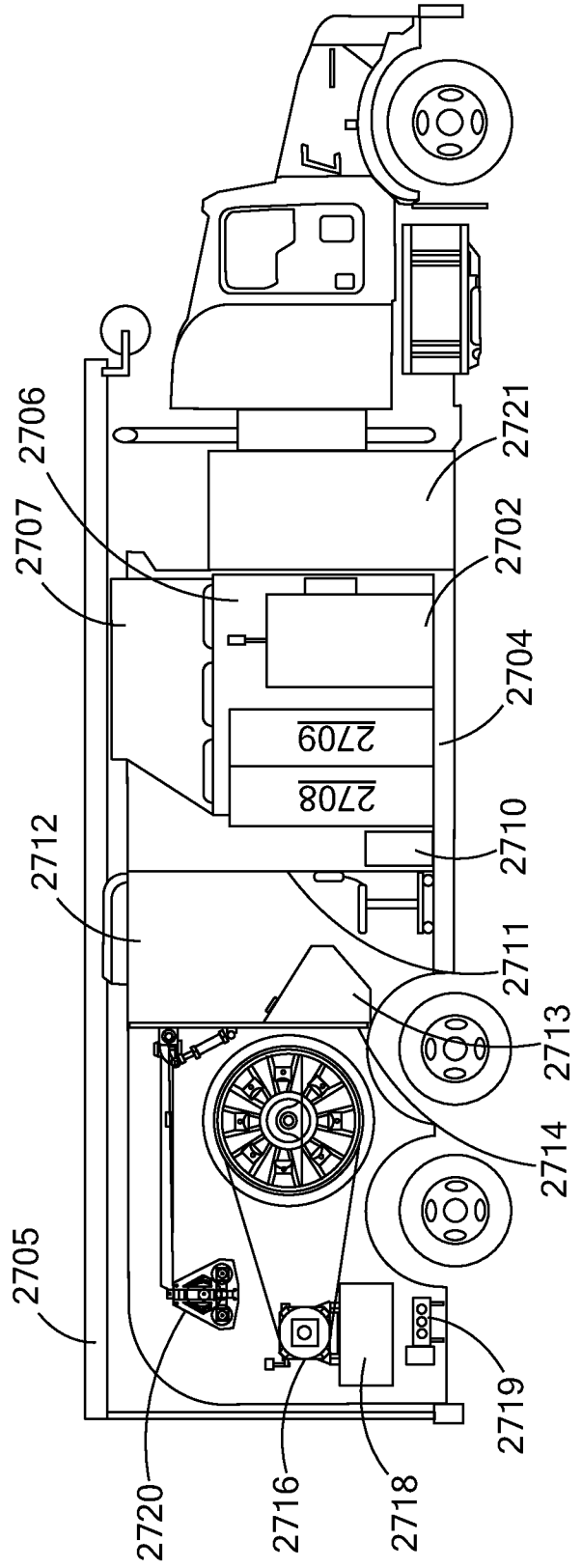

Fig. 27C



23/29

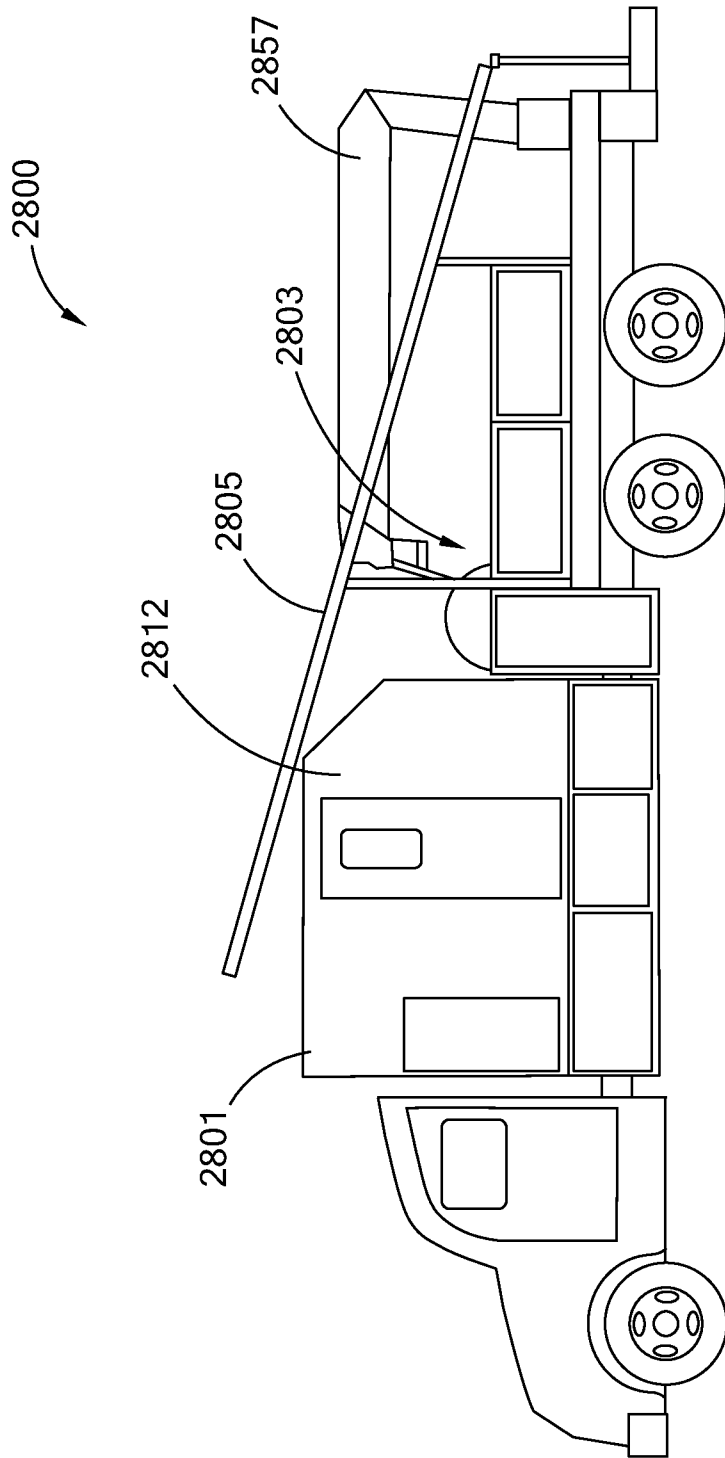

Fig. 28

24/29

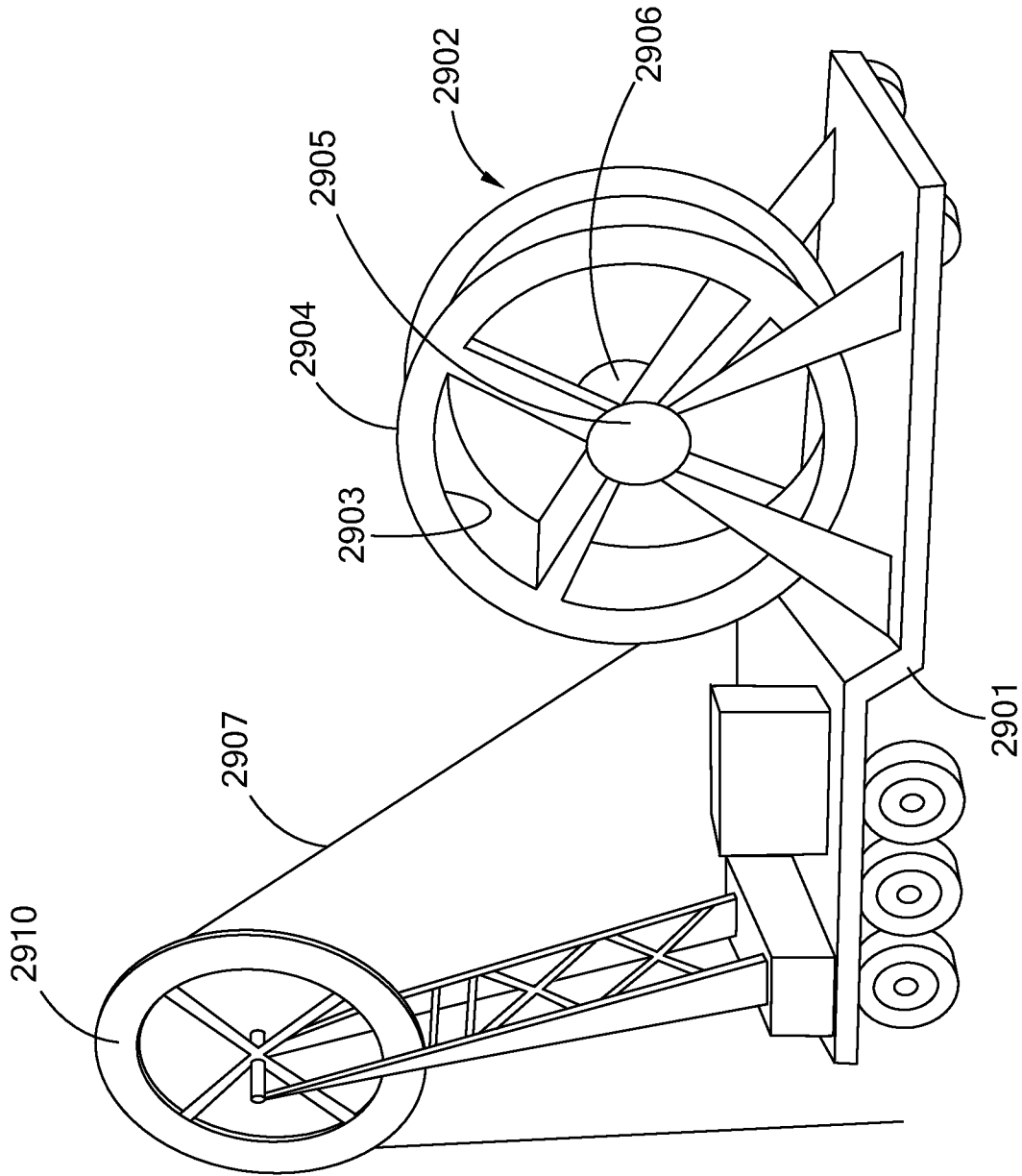

Fig. 29

25/29

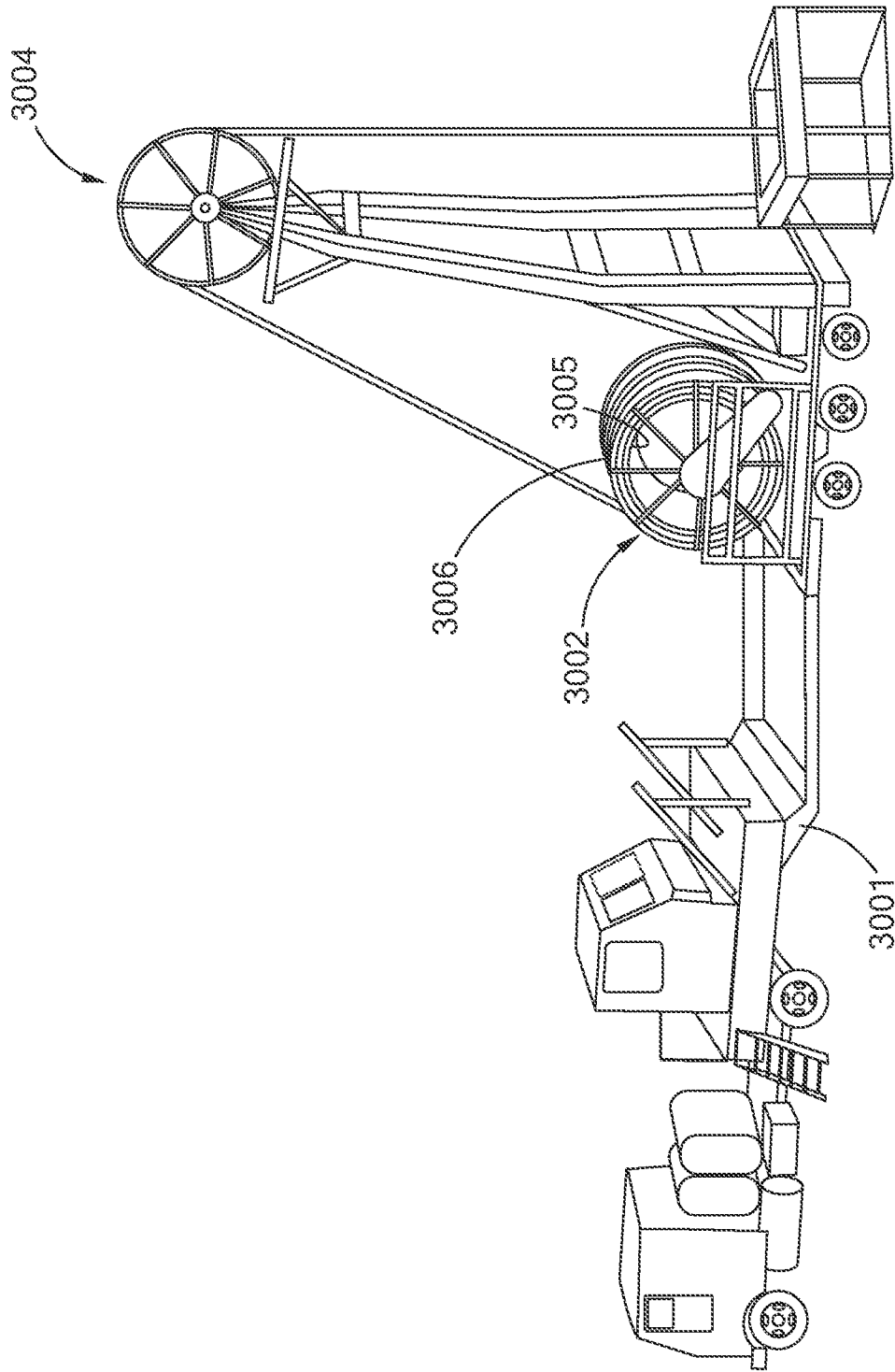

Fig. 30

26/29

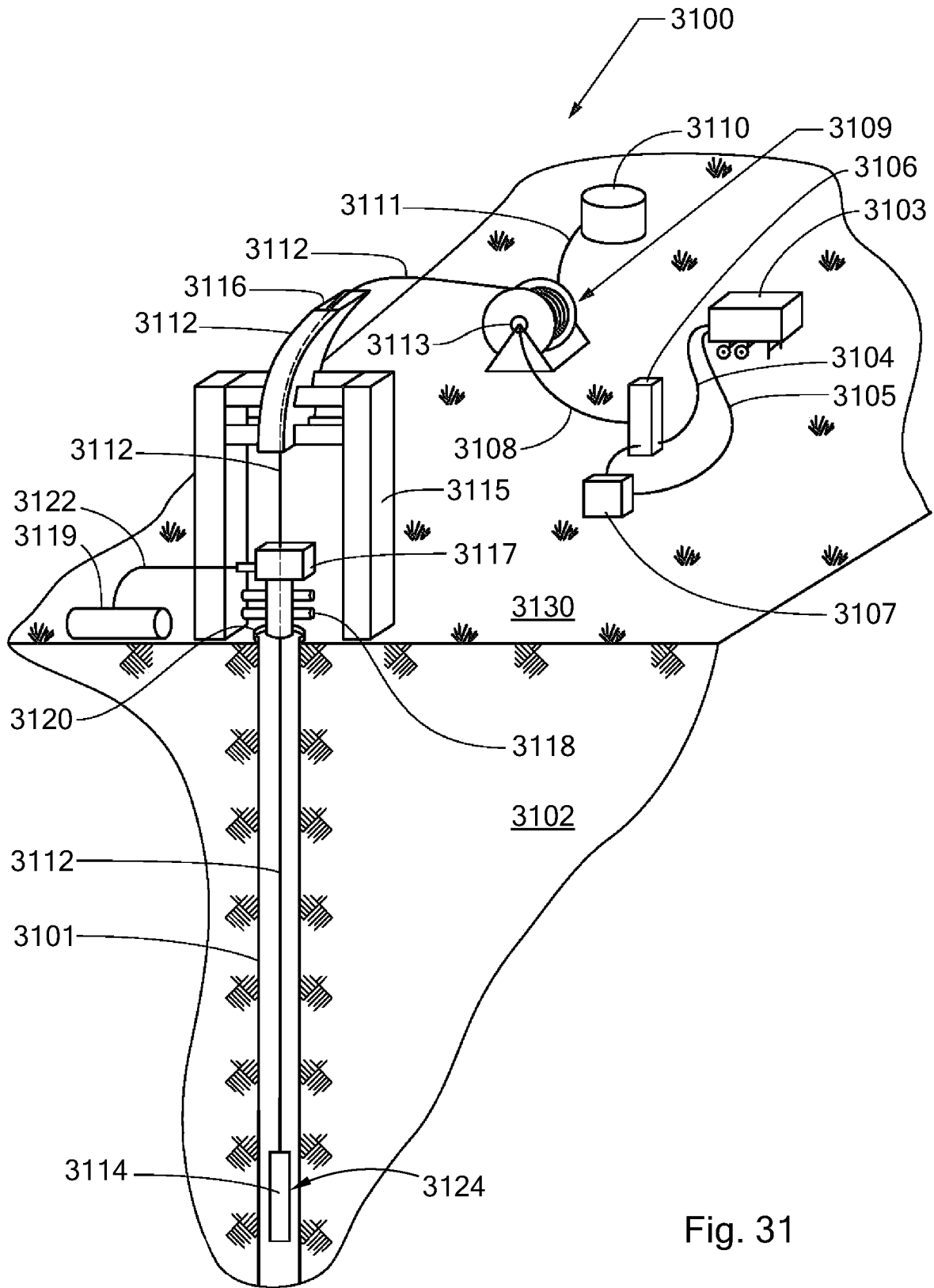

Fig. 31

27/29

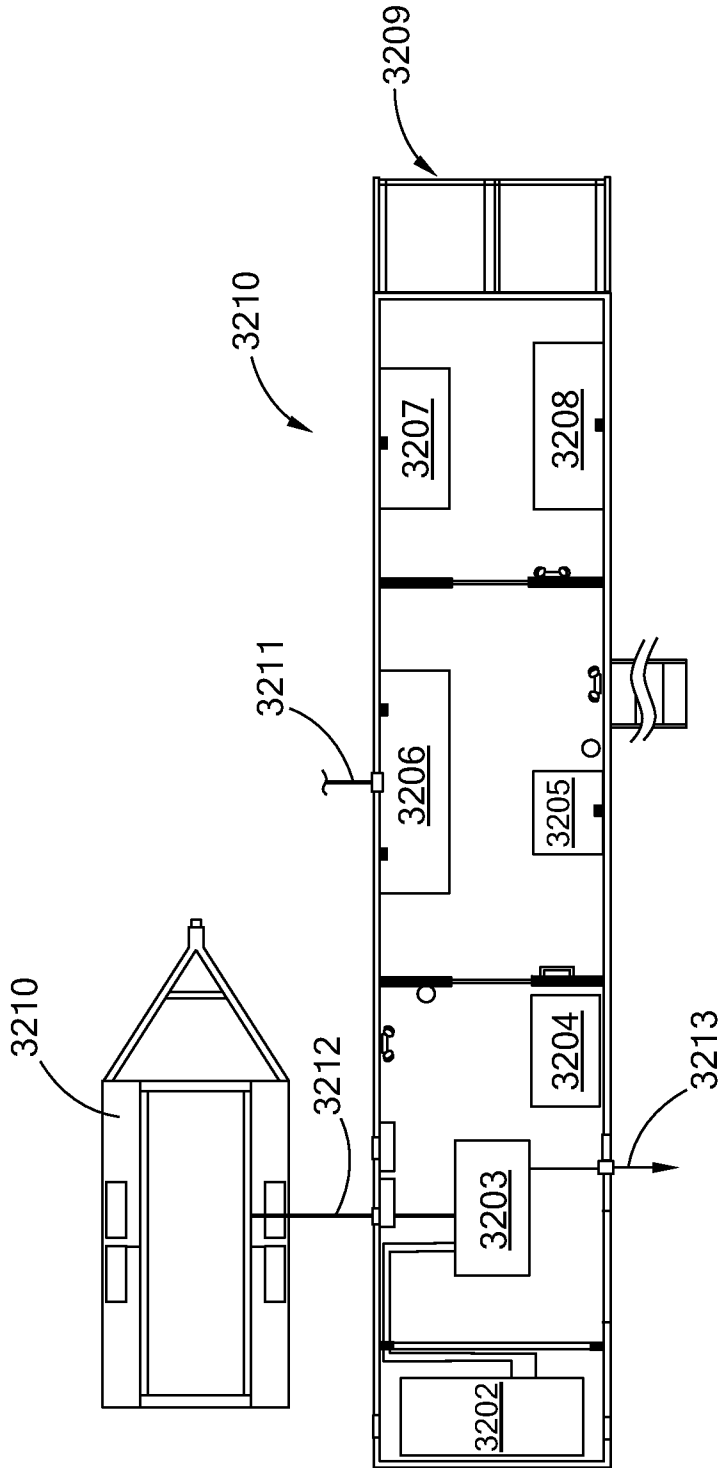

Fig. 32A



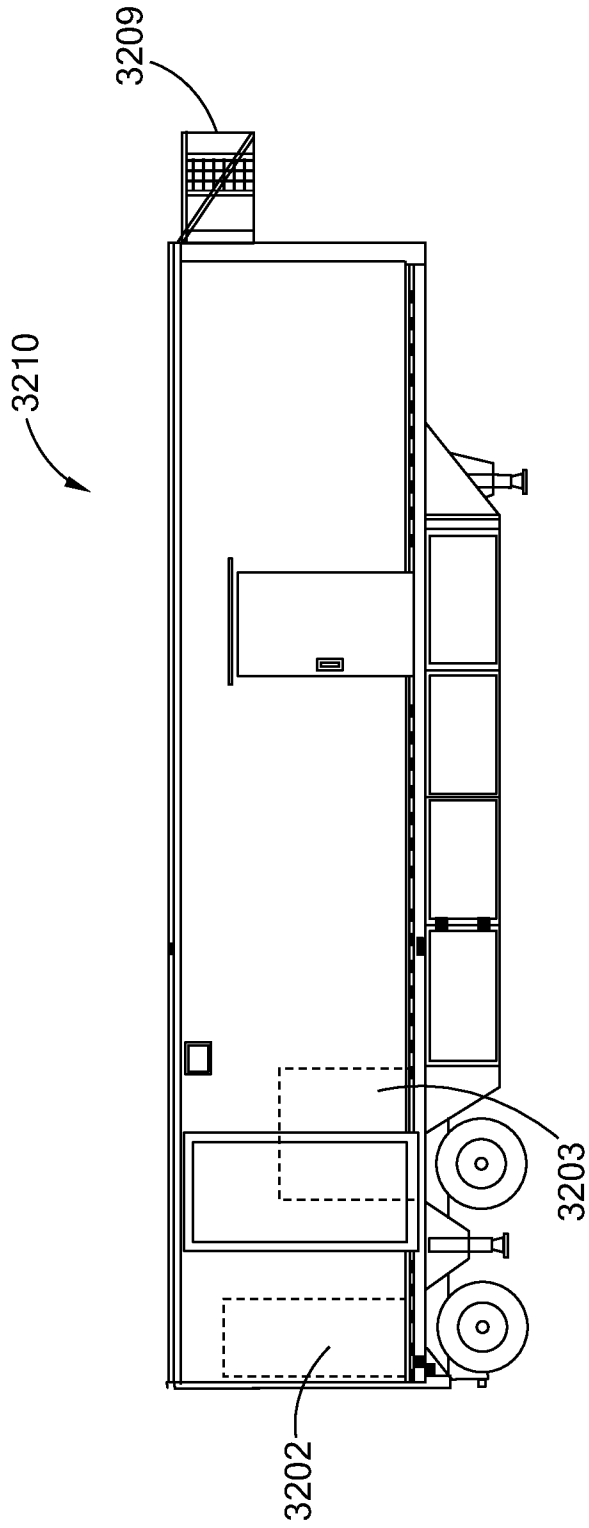

Fig. 32B

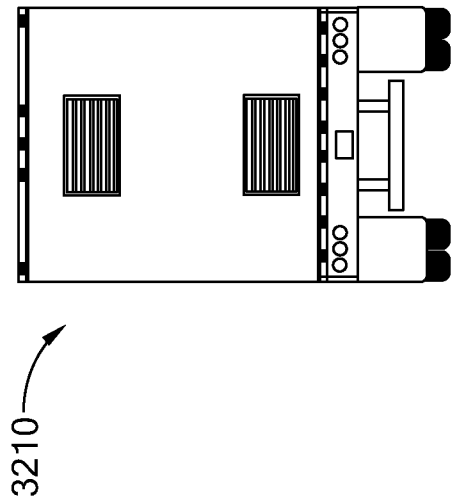

Fig. 32C

29/29

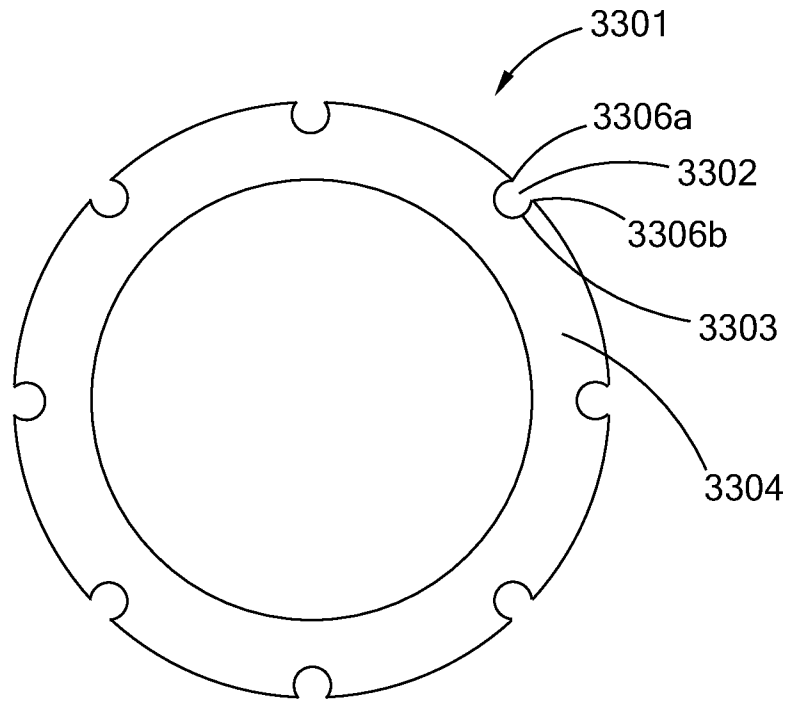

Fig. 33

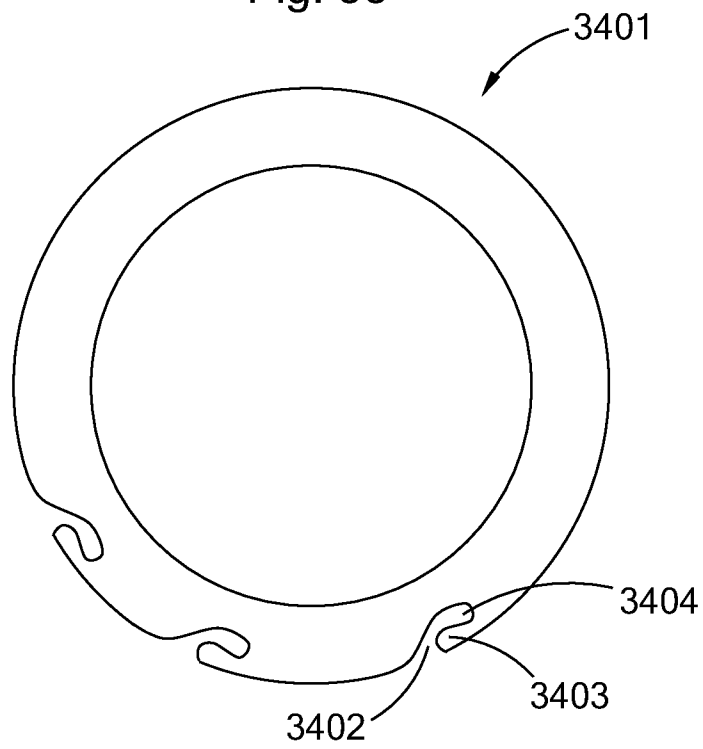

Fig. 34

## INTERNATIONAL SEARCH REPORT

International application No.

PCT/US2011/047902

<b>A. CLASSIFICATION OF SUBJECT MATTER</b> IPC(8) - E21C 37/16 (2011.01) USPC - 175/16 According to International Patent Classification (IPC) or to both national classification and IPC		
<b>B. FIELDS SEARCHED</b> Minimum documentation searched (classification system followed by classification symbols) IPC(8) - E21B 43/00; E21C 37/16; B65H 18/28 (2011.01) USPC - 175/16; 166/65.1; 242/159 Documentation searched other than minimum documentation to the extent that such documents are included in the fields searched Electronic data base consulted during the international search (name of data base and, where practicable, search terms used) MicroPatent, Google Scholar		
<b>C. DOCUMENTS CONSIDERED TO BE RELEVANT</b>		
Category*	Citation of document, with indication, where appropriate, of the relevant passages	Relevant to claim No.
X	US 2010/0044103 A1 (MOXLEY et al) 25 February 2010 (25.02.2010) entire document	1-12 and 16-20
-		----
Y		13-15
Y	US 4,436,177 A (ELLISTON) 13 March 1984 (13.03.1984) entire document	13-15
A	US 2010/0044106 A1 (ZEDIKER et al) 25 February 2010 (25.02.2010) entire document	1-20
A	US 2007/0227741 A1 (LOVELL et al) 04 October 2007 (04.10.2007) entire document	1-20
<input type="checkbox"/> Further documents are listed in the continuation of Box C. <input type="checkbox"/>		
* Special categories of cited documents: "A" document defining the general state of the art which is not considered to be of particular relevance "E" earlier application or patent but published on or after the international filing date "L" document which may throw doubts on priority claim(s) or which is cited to establish the publication date of another citation or other special reason (as specified) "O" document referring to an oral disclosure, use, exhibition or other means "P" document published prior to the international filing date but later than the priority date claimed "T" later document published after the international filing date or priority date and not in conflict with the application but cited to understand the principle or theory underlying the invention "X" document of particular relevance; the claimed invention cannot be considered novel or cannot be considered to involve an inventive step when the document is taken alone "Y" document of particular relevance; the claimed invention cannot be considered to involve an inventive step when the document is combined with one or more other such documents, such combination being obvious to a person skilled in the art "&" document member of the same patent family		
Date of the actual completion of the international search 05 January 2012		Date of mailing of the international search report <b>17 JAN 2012</b>
Name and mailing address of the ISA/US Mail Stop PCT, Attn: ISA/US, Commissioner for Patents P.O. Box 1450, Alexandria, Virginia 22313-1450 Facsimile No. 571-273-3201		Authorized officer: Blaine R. Copenheaver PCT Helpdesk: 571-272-4300 PCT OSP: 571-272-7774