

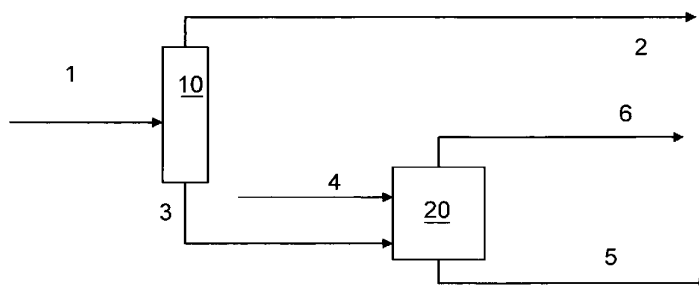

- (51) International Patent Classification:
C02F 1/42 (2006.01) C02F 1/04 (2006.01)
- (21) International Application Number:
PCT/EP2009/003850
- (22) International Filing Date:
28 May 2009 (28.05.2009)
- (25) Filing Language: English
- (26) Publication Language: English
- (30) Priority Data:
MI2008A 001035 6 June 2008 (06.06.2008) IT
- (71) Applicant (for all designated States except US): ENI S.P.A. [IT/IT]; Piazzale E. Mattei 1, I-00144 Rome (IT).
- (72) Inventors; and
- (75) Inventors/Applicants (for US only): MIGLIO, Roberta [IT/IT]; Via Borzighella 3, I-28047 Oleggio-Novara (IT). BIGNAZZI, Renzo [IT/IT]; Via Ciro Menotti 127, I-20025 Legnano (Milano) (IT).
- (74) Agents: DE GREGORI, Antonella et al.; Barzano' & Zanardo Milano S.P.A., Via Borgonuovo 10, I-20121 Milan (IT).
- (81) Designated States (unless otherwise indicated, for every kind of national protection available): AE, AG, AL, AM, AO, AT, AU, AZ, BA, BB, BG, BH, BR, BW, BY, BZ, CA, CH, CN, CO, CR, CU, CZ, DE, DK, DM, DO, DZ, EC, EE, EG, ES, FI, GB, GD, GE, GH, GM, GT, HN, HR, HU, ID, IL, IN, IS, JP, KE, KG, KM, KN, KP, KR, KZ, LA, LC, LK, LR, LS, LT, LU, LY, MA, MD, ME, MG, MK, MN, MW, MX, MY, MZ, NA, NG, NI, NO, NZ, OM, PG, PH, PL, PT, RO, RS, RU, SC, SD, SE, SG, SK, SL, SM, ST, SV, SY, TJ, TM, TN, TR, TT, TZ, UA, UG, US, UZ, VC, VN, ZA, ZM, ZW.
- (84) Designated States (unless otherwise indicated, for every kind of regional protection available): ARIPO (BW, GH, GM, KE, LS, MW, MZ, NA, SD, SL, SZ, TZ, UG, ZM, ZW), Eurasian (AM, AZ, BY, KG, KZ, MD, RU, TJ, TM), European (AT, BE, BG, CH, CY, CZ, DE, DK, EE, ES, FI, FR, GB, GR, HR, HU, IE, IS, IT, LT, LU, LV, MC, MK, MT, NL, NO, PL, PT, RO, SE, SI, SK, TR), OAPI (BF, BJ, CF, CG, CI, CM, GA, GN, GQ, GW, ML, MR, NE, SN, TD, TG).
- Published:
— with international search report (Art. 21(3))

(54) Title: PROCESS FOR THE TREATMENT OF THE AQUEOUS STREAM COMING FROM THE FISCHER-TROPSCH REACTION BY MEANS OF ION EXCHANGE RESINS

Fig. 1



(57) Abstract: Process for the treatment of the aqueous stream coming from the Fischer-Tropsch reaction comprising: feeding the aqueous stream containing the organic by products of the reaction to a distillation or stripping column; separation from the column of an aqueous stream enriched in alcohols having from 1 to 8 carbon atoms and other possible volatile compounds; feeding the aqueous stream containing the organic acids leaving the bottom of the distillation column to an ion exchange step wherein said aqueous stream is put in contact with an anionic exchange resin bed and the production of two outgoing aqueous streams: an aqueous stream (i) enriched in organic acids having from 1 to 8 carbon atoms; a purified aqueous stream (ii) with a low content of organic acids.

WO 2009/146854 A1

5

PROCESS FOR THE TREATMENT OF THE AQUEOUS STREAM COMING
FROM THE FISCHER-TROPSCH REACTION BY MEANS OF ION EX-
CHANGE RESINS

The present invention relates to a process for the
10 treatment of the water co-produced in the Fischer-Tropsch
synthesis, by means of ion exchange resins.

More specifically, the invention relates to a process
for the treatment of the water co-produced in the
Fischer-Tropsch reaction by means of the combination of a
15 distillation/stripping step and an ion exchange step.

The Fischer-Tropsch technology for preparing hydro-
carbons from blends of gas based on hydrogen and carbon
monoxide, known as synthesis gas, is well known in scien-
tific literature. A summary recapitulating the main works
20 on the Fischer-Tropsch reaction is contained in the Bu-
reau of Mines Bulletin, 544 (1955) with the title of
"Bibliography of the Fischer-Tropsch Synthesis and Re-
lated Processes" H.C. Anderson, J.L. Wiley and A. Newell.

The production process of liquid hydrocarbons by
25 means of the Fischer-Tropsch reaction generates an amount

of water, by weight, greater than that of the hydrocarbons, due to the production of a mole of water for each mole of CO converted into hydrocarbons.

Before purification, the reaction water (co-produced
5 water) is subjected to preliminary separation. It normally passes through a triphase separator, from which an organic condensate is obtained, together with a vapour phase and an aqueous phase, still containing organic compounds, both dissolved and in suspension, and is preferably
10 bly treated in a coalescence filter.

The water thus separated remains contaminated by hydrocarbon compounds, typically less than 1000 ppm and by oxygenated compounds, soluble in water. The amount of contaminants depends on the catalyst and on the reaction
15 conditions, in particular the temperature and pressure. On the whole, the amount of oxygenated compounds increases with an increase in the reaction temperature, the class of the organic acids in a more significant way. The main oxygenated contaminants are light alcohols such as
20 methanol and ethanol, indicatively present from 0.5% by weight to 5% by weight. Heavier alcohols are also present in lower amounts (for example, propanol, butanol, pentanol, etc.) and other oxygenated compounds, such as aldehydes (acetaldehyde, propionaldehyde, butyraldehyde,
25 etc.), ketones (acetone, methylethylketone, etc.) and ac-

ids (for example, formic acid, acetic acid, propionic acid, butyric acid, iso-butyric acid, valeric acid, hexanoic acid, heptanoic acid, octanoic acid, etc.), these latter indicatively present at concentrations lower than 5 1.5% by weight. The amount of compounds present within each group decreases with an increase in the molecular weight, and compounds with up to 25 carbon atoms can be found. The water can contain small amounts of nitrogenated and sulphurated compounds which derive from the 10 feedstock used, in addition to traces of metals coming from the reactor. The metals can also be present in the form of suspended solids.

The stream as such has no commercial value and cannot be disposed of as such, the oxygenated compounds (acids), 15 moreover, confer corrosive properties, the hydrocarbons give the tendency of forming foams (foaming).

Meteoric water or other forms of service water present in the production site, can be added to the water co-produced.

20 A water treatment plant is therefore necessary for the re-use of the water within the Fischer-Tropsch process, for example, as cooling water in the synthesis section, or for its outward disposal or for other possible uses, as irrigation water or drinking water.

25 The treatment or combination of treatments on the wa-

ters co-produced is determined by the restrictions imposed by the final destination of the water and by the organic compounds present therein.

The water treatment plant is normally of the biological type, which can be preceded by a treatment, typically stripping/distillation, to remove the most volatile organic compounds. The water coming from the biological treatment is normally subjected to a further finishing treatment to remove the solid products and, if necessary, also the residual salts from the biological treatment. An approach of this type is described, for example, in US 7,166,219, US 7,150,831, US 7,153,392 (SASOL) and WO 2005/113426 (STATOIL - PETROLEUM OIL & GAS CORP. SOUTH AFRICA).

In some phases of the plant management, the presence in the co-produced water of metals and of suspended solids deriving from the catalyst, is also significant and must therefore be specifically controlled in relation to the final use of the water, as described, for example, in WO 2006/108195 (STATOIL).

When the water is treated by means of a biological process, the organic compounds contained therein are degraded to CO_2 , H_2O or CO_2 , CH_4 and H_2O , and the dosage of the "chemicals" required by the biological process, of both the aerobic type and anaerobic type, leads to the

production of a sludge, which can indicatively vary from 0.05 kg to 0.5 kg per kg of biodegraded COD.

Biological treatments are, normally, expensive as a result of the chemicals to be used (for example urea, phosphates, etc.), of the large volumes of the treatment tanks/reactors, of the times of the biological reactions which are in the order of hours, and of the air to be insufflated, when aerobic treatment is used. Another jeopardizing effect of biological treatment is that the organic compounds present in the water cannot be upgraded.

Should the organic compounds present in the co-produced water be upgraded, instead of biodegraded, a physico-chemical treatment must be applied. In US 6,462,097 (IFP-ENI), for example, a process is described in which, after the stripping treatment, an adsorption step on activated carbons is envisaged. Subsequently, the stream coming from said adsorbing step on activated carbons, rich in organic compounds, can be fed back to the synthesis reactor. Similar suggestions are also mentioned, for example, in US 6,225,358 (SYNTROLEUM CORP), US 5,053,581, US 5,004,862 (EXXON), in which, potentially, the organic compounds, for example C₁ to C₆ alcohols present in the co-produced water, are transformed into simple molecules such as CO_x/H₂ (syngas) and then upgraded.

Other types of treatment, of a physico-chemical nature, allow one or more aqueous streams enriched in organic compounds to be separated, simultaneously with the production of water purified to the required degree.

5 A mainly alcoholic stream with an amount of non-acid compounds (NAC) of 55% by weight up to a max of 85% by weight, can be separated by distillation, for example, as described in US 2004/0262199 (SASOL) and in Italian patent application MI07A001209 (ENI). This stream can be
10 used as fuel or, alternatively, it can be further processed to recover valuable products:

The formation, by means of physico-chemical treatments, of one or more streams enriched in different groups of organic products, together with the production
15 of water purified to the required degree, is described, for example, in US 7,153,432 (SASOL) in which a process of at least two steps is proposed, the first, a distillation step, the second, membrane separation and, in addition, other accessory steps, when necessary, to bring the
20 purified water back to the required degree of purity.

It has now been found that, by means of the original combination of two types of physico-chemical treatments, such as distillation and ion exchange, the separation of an aqueous stream enriched in alcohols and an aqueous
25 stream enriched in organic acids, from the water co-

produced in the Fischer-Tropsch synthesis can be effected simply and conveniently and, at the same time, purified water at the desired degree can be obtained.

The purified water can be of a quality suitable for
5 its reuse in the same process, or suitable for use in agriculture, or to be disposed off as surface water, according to the legislations in force.

In accordance with this, an object of the present invention relates to a process for the treatment of the
10 aqueous stream coming from the Fischer-Tropsch reaction comprising:

- feeding the aqueous stream containing the organic by-products of the reaction to a distillation or stripping column;
- 15 - separation from the column of an aqueous stream enriched in alcohols having from 1 to 8 carbon atoms and other possible volatile compounds;
- feeding the aqueous stream containing the organic acids coming from the bottom of the distillation column
20 to an ion exchange step wherein said aqueous stream is put in contact with an anionic exchange resin bed and the production of two outgoing aqueous streams;
- an aqueous stream (i) enriched in organic acids having from 1 to 8 carbon atoms;
- 25 - a purified aqueous stream (ii) with a low content of

organic acids.

The aqueous stream (i) and the aqueous stream (ii) can possibly contain salts of organic acids contained therein. If present, however these salts are in an amount
5 lower than 5% by weight with respect to the total amount of said organic acids.

In practice, the reaction water, together with other possible process water, is subjected to distillation, after possible cooling.

10 The aqueous stream containing the organic acids leaving the bottom of the distillation column, is put in contact with anionic exchange resins, in order to subtract the anions of the organic acids from this aqueous stream and to release hydroxide ions, which is equivalent to re-
15 moving the organic acids present.

According to the regeneration method of the anionic exchange resins, the process of the invention can also include an electrodialysis step in order to separate from the aqueous stream (i) enriched in organic acids deriving
20 from the ion exchange step in the form of salts, an aqueous stream (iii) enriched in organic acids and a basic aqueous stream (iv) containing, for example, NaOH which can be re-used in the ion exchange treatment for the regeneration of the resins.

25 The Fischer-Tropsch reaction can be effected as de-

scribed in patent US 6,348,510.

According to the specific purification requirements (final use), additional preliminary, intermediate and final steps can also be included, such as filtration, for
5 example.

The aqueous stream enriched in alcohols has an alcohol concentration preferably ranging from 25% by weight to 75% by weight; the aqueous stream (i) enriched in organic acids has a concentration of organic acids preferably ranging from 3% by weight to 10% by weight; the purified aqueous stream (ii) with a low content of organic acids, has a concentration of organic acids preferably
10 lower than 0.01% by weight.

The aqueous stream coming from the Fischer-Tropsch
15 reaction is preferably first subjected to distillation and the aqueous stream containing the organic acids leaving the bottom of the distillation column is fed to the ion exchange step.

Alternatively, the aqueous stream coming from the
20 Fischer-Tropsch reaction can be first fed to the ion exchange step and the distillation can be subsequently effected on the purified aqueous stream (ii) with a low content of organic acids leaving the ion exchange step.

Should the aqueous stream to be treated contain metallic cations in solution and the regeneration of the
25

resin also be effected by means of an electro dialysis step, it is convenient to treat said aqueous stream on a cationic exchange resin bed or a bed of chelating resin, in acid form, before being put in contact with an anionic
5 exchange resin bed.

Among the anionic exchange resins which can be advantageously used in the process of the present invention, there are strong basic resins having at least one functional group selected from quaternary ammonium groups and
10 the weak basic resins having at least one amine functional group. Weak basic resins are preferred. Among the various commercial resins, resins having a divinyl benzene-styrene matrix or an acrylic divinyl benzene matrix, with at least one amine functional group, are preferred.

15 The aqueous stream containing organic acids leaving the bottom of the column is put in contact with the resin bed, typically by fluxing on the resin bed.

The resins used are preferably in the form of hydroxide (OH), so that in the aqueous stream treated no other
20 anions are released during the exchange with the anions of the organic acids (carboxylic). If the resins are available in other forms, they are preferably converted into OH form.

There are no particular restrictions on the concentrations of the aqueous solutions to be used for convert-
25

ing the resins into a suitable form. Normally the aqueous solutions have a concentration of 1% by weight to 10% by weight, preferably of from 3% by weight to 7% by weight, for example an aqueous solution of NaOH with a concentration of from 4% by weight to 6% by weight, can be used.

According to the present invention, it is preferable to operate with a configuration which includes two or more anionic exchange resin beds, situated in series and/or in parallel with respect to the flow of the aqueous stream to be treated, in order to always have at least one bed operating in the removal step of the organic acids, preferably two in series, and at least one bed in regeneration or washing phase. When two beds in series are present in the removal phase, the first bed is inserted as second in the subsequent cycle. In this way, each resin bed is cyclically subjected to a removal phase of the organic acids (A) and to a regeneration phase (B), the two mentioned phases can be alternated with washing phases with deionized water.

The removal phase of organic acids (A) can be effected in a specific fixed bed reactor, the space velocity BV/h (wherein BV/h = liquid stream volume/resin volume/h) at which the aqueous stream is put in contact with the resin bed preferably ranges from 1 BV/h to 10 BV/h, more preferably from 1 BV/h to 5 BV/h, whereas there is

no limitation with respect to the pressure which must only be sufficient for compensating the load drops of the resin bed. Suitable temperatures are preferably lower than 60°C, more preferably lower than 50°C.

5 There are no restrictions with respect to the concentrations of the acid aqueous streams which can be treated, even if, within the scope of the present invention, acid aqueous streams having a content of organic acids lower than 1.5% by weight are preferred, even more
10 preferably of from 0.05% by weight to 0.30% by weight. The presence of alcohols or hydrocarbons at an overall level lower than 5% by weight does not significantly interfere with the removals.

 The amount of acid aqueous stream which can be purified depends on the exchange capacity of the resin used
15 and on the concentration of anions present in the acid aqueous stream. When the removal of the organic acids from the aqueous stream which has been put in contact with the resin is no longer sufficiently effective, the
20 resin must be regenerated.

 On the basis of the operative capacity of the resin used, of the BV volume of the aqueous stream treated (where BV = liquid stream volume/resin volume), of the breakthrough curve, as known to experts in the field, purified water can be obtained having a low content of re-
25

residual organic acids, for example, a content of organic acids lower than 0.012% by weight, suitable for irrigation or industrial use, or lower than 0.001% by weight, with a conductivity lower than 5 microS/cm, essentially free of salts. The residual traces of alcohols, for example, methanol, and hydrocarbons present in the aqueous stream leaving the bottom of the distillation column either remain unaltered or are further reduced after the contact with the resin bed.

10 The process by which the regeneration phase of the resin (B) is carried out, is essential for producing a stream enriched in organic acids simultaneously with a stream purified to the required degree. The regeneration phase of the anionic exchange resin situated in a fixed bed is generally carried out at a space velocity of the
15 regenerating aqueous solution of 0.5 BV/h to 20 BV/h, preferably from 1 BV/h to 5 BV/h.

The resin bed can be regenerated (phase B) by fluxing with an aqueous solution of a strong acid, for example an
20 aqueous solution of HCl at a concentration ranging from 1% by weight to 10% by weight, preferably from 3% by weight to 7% by weight, in an at least stoichiometric amount with respect to the anions of the organic acids charged on the resins during the removal phase of the
25 organic acids (A), producing a stream concentrated in or-

ganic acids and a resin bed in the form of chloride. The resin bed is fluxed with deionized water to remove the wetting liquid of the resin and then fluxed with a basic aqueous solution, for example, an aqueous solution of NaOH at a concentration of from 1% by weight to 10% by weight, preferably of from 3% by weight to 7% by weight, in an amount equal to the capacity of the resin saturated with acid, producing a basic aqueous solution of NaCl essentially free of organic acids having, for example, a COD lower than 160 ppm. If necessary, the resin bed is fluxed again with deionized water, so that it is suitable for the subsequent removal phase of the organic acids (A).

Alternatively, the resin bed can be regenerated (phase B) by fluxing with a basic aqueous solution, for example, an aqueous solution of NaOH, having a concentration of from 1% by weight to 10% by weight, preferably of from 3% by weight and 7% by weight, producing a stream of salified organic acids.

The above-mentioned stream of salified organic acids has, at the outlet, a weight concentration typically higher than the regenerated aqueous solution, which increases according to the ratio between the molecular weight of the base and the average molecular weight of the organic acids present in the stream and which are

salified.

The regenerating aqueous solution is used in such an amount so as to be normally equal to or to exceed the stoichiometric amount necessary for regenerating the resin. The reagents for the regeneration are preferably
5 selected from sodium hydroxide and potassium hydroxide.

The fluxing with the basic aqueous solution can be separated from the removal phase of the organic acids (A) by a washing phase, for example with deionized water, in
10 order to avoid the contact between the acid water and the basic aqueous solution. When the washing phase is not interposed between the removal phase of the organic acids and the resin regeneration, various recyclings must be included, for example, to ensure that the aqueous stream
15 is purified to the required degree and at the same time, the base used is completely converted to salt. After the regeneration, for example, the first volume (1 BV) or fraction of volume, of the aqueous stream is fed to a resin bed containing, as wetting liquid, an aqueous solu-
20 tion containing the salified organic acids and the possible excess of base; the corresponding volume of stream leaving the resin bed will not be purified to the required degree, but resort can be made to a re-use/recycling of said volume in the regeneration phase,
25 after the addition of the base in the amount required by

the stoichiometry.

The aqueous solution of salified organic acids is subjected to an electro dialysis treatment in a bipolar configuration, to obtain an aqueous stream containing organic acids at a concentration preferably ranging from 5% by weight to 9% by weight and a basic aqueous solution, for example an aqueous solution of NaOH at a concentration preferably ranging from 3% by weight to 7% by weight to be recirculated as basic aqueous solution for the regeneration of the resin, except for a possible addition of a base. The above-mentioned aqueous stream containing organic acids can still contain residues of said salified organic acids.

Said salified organic acids, however, if present, are in an amount lower than 5% by weight with respect to the total amount of said organic acids.

The dimensioning of the beds and the number of lines, in series and/or in parallel, and the possibility of recycling of inner aqueous streams for the preparation of the regenerating aqueous streams, is mainly effected, as is known in the field, on the basis of the concentration of organic acids in the aqueous stream leaving the bottom of the distillation column, and of the residual amount of organic acids to be obtained in the purified aqueous stream.

The passage on the resins can also precede the distillation.

A further purification step on a cationic resin bed or with chelating agents can be added to the purification process with anionic exchange resins, according to the
5 necessity for operations which must be effected downstream on the purified aqueous stream.

Some illustrative and non-limiting examples are provided hereunder for a better understanding of the present
10 invention and for its embodiment.

EXAMPLE 1

After effecting the Fischer-Tropsch reaction as disclosed by patent US 6,348,510 (IFP-ENI) and with reference to Figure 1, the water which is separated by decanting from the reaction effluent (stream 1) is fed to a
15 distillation column (10). An aqueous stream rich in alcohols (stream 2) is separated from the head of the column, whose composition, obtained by gas-chromatography, is reported in Table 1.

20 The composition of the water which is separated by decanting from the reaction effluent, obtained by means of gas-chromatography, is reported in Table 1 (stream 1).

The aqueous stream leaving the bottom of the distillation column (stream 3), whose composition, obtained by
25 gas-chromatography (to determine the amount of alcohols)

and by means of ionic chromatography (to determine the amount of organic acids) is reported in Table 1, is subsequently fed to an anionic exchange resin bed (20) of the type AMBERLYST A24 of Rohm&Haas. After fluxing 12 BV of aqueous stream leaving the bottom of the distillation column, at 25°C and a flow equal to 10 BV/h, the COD of the aqueous stream leaving the resin bed is proved to be lower than 5 mg O₂/l, with a conductivity lower than 4 microS/cm. The resin was fluxed with a total of 50 BV of the aqueous stream leaving the bottom of the distillation column. During the fluxing, samples of a stream leaving the resin bed were collected, and an analysis of the organic acids contained therein was effected by means of ionic chromatography. The results are shown in Figure 2.

The resin was then fluxed with 4 BV of deionized water, with 2 BV of an aqueous solution of NaOH at 5.2% by weight, with 10 BV of deionized water (stream 4) and finally fluxed again with the aqueous stream leaving the bottom of the column (stream 3). The resin was fluxed with a total of 43 BV of the aqueous stream leaving the bottom of the distillation column, the aqueous stream was entirely collected and an analysis of the organic acids present was effected by means of ionic chromatography (stream 5): the results obtained are reported in Table 1.

The regeneration was also repeated by entirely col-

lenting the stream (stream 6) leaving the resin after further fluxing of 2 BV of an aqueous solution of NaOH at 5.2% by weight and 1 BV of washing water. Therefore, an analysis of the salified organic acids was effected by means of ionic chromatography and the results obtained are reported in Table 1.

EXAMPLE 2

After effecting the Fischer-Tropsch reaction as disclosed by patent US 6,348,510 (IFP-ENI) and with reference to Figure 3, the water which is separated by decanting from the reaction effluent (stream 1) is fed to a distillation column (10).

The composition of the water separated by decanting from the reaction effluent, obtained by gas-chromatography, is reported in Table 2.

A stream enriched in alcohol (stream 2), whose composition, obtained by means of gas-chromatography, is reported in Table 2, is separated from the head of the column. 85 BV of the aqueous stream leaving the bottom of the column (stream 3) whose composition, obtained by gas-chromatography (to determine the amount of alcohols) and by means of ionic chromatography (to determine the amount of organic acids), is reported in Table 2, are fed to the resin bed as described in example 1. The stream leaving the resin bed (stream 5) was entirely collected and an

analysis of the organic acids present was effected by means of ionic chromatography. The results obtained are reported in Table 2.

1.3 BV of an aqueous solution of HCl at 4.8% by weight and 2 BV of deionized water (stream 4) were then fed. A sample was collected of the corresponding outgoing stream (stream 6) equal to 0.5 BV, in correspondence with the lower pH value (pH = 0.4) and an analysis of the organic acids present was effected by means of ionic chromatography: the results obtained are reported in Table 2.

1.9 BV of an aqueous solution of NaOH at 5.2% (stream 7) were subsequently fed (excess of 50% with respect to the exchange capacity of the resin). The corresponding aqueous stream at the outlet has a pH > 7 (stream 8).

20

25

Table 1

	Stream 1	Stream 3	Stream 5	Stream 6	Stream 2	
	Column inlet	Column bottom stream	Purified stream	Stream enriched in salified acids	Stream enriched in alcohols	
5						
	Conductivity (micros/cm)	n.d.	305	n.d.	n.d.	
	pH	n.d.	3.0	n.d.	n.d.	
	Alcohols (% by weight)					
	C ₁ H ₄ O ₁	2.3	0.004	0.001	n.d.	41.19
	C ₂ H ₆ O ₁	0.77	0.001	n.d.	n.d.	13.56
10	C ₃ H ₈ O ₁	0.32	0.0008	n.d.	n.d.	5.73
	C ₄ H ₁₀ O ₁	0.18	< 0.0005	n.d.	n.d.	3.20
	C ₅ H ₁₂ O ₁	0.07	n.d.	n.d.	n.d.	1.29
	C ₆ H ₁₄ O ₁	0.02	n.d.	n.d.	n.d.	0.35
	Total	3.66	< 0.006	0.001.	--	65.32
	Acids (% by weight)					
15	C ₁ H ₂ O ₂	n.d.	0.023	0.0002	0.266	n.d.
	C ₂ H ₄ O ₂	n.d.	0.133	0.0012	2.04	n.d.
	C ₃ H ₆ O ₂	n.d.	0.059	0.0022	0.759	0.0084
	C ₄ H ₈ O ₂ iso	n.d.	0.006	0.0003	0.101	n.d.
	C ₄ H ₈ O ₂	n.d.	0.028	0.0013	0.541	0.006
	C ₅ H ₁₀ O ₂	n.d.	0.021	0.0006	0.236	0.002
	C ₆ H ₁₂ O ₂	n.d.	0.004	< 0.0002	0.060	0.001
20	Total	n.d.	0.274	< 0.006	4.0	0.017

n.d. : not determined

Table 2

	Stream 1	Stream 3	Stream 5	Stream 6	Stream 2
	Column inlet	Column bottom stream	Purified stream	Stream enriched in salified acids	Stream enriched in alcohols
Conductivity (micros/cm)	n.d.	355	n.d.	n.d.	n.d.
pH	n.d.	3.4	7	0.4	n.d.
Alcohols (% by weight)					
C ₁ H ₄ O ₁	2.46	0.002	0.002	n.d.	41.19
C ₂ H ₆ O ₁	0.8	n.d.	n.d.	n.d.	13.56
C ₃ H ₈ O ₁	0.34	n.d.	n.d.	n.d.	5.73
C ₄ H ₁₀ O ₁	0.19	n.d.	n.d.	n.d.	3.20
C ₅ H ₁₂ O ₁	0.08	n.d.	n.d.	n.d.	1.29
C ₆ H ₁₄ O ₁	0.02	n.d.	n.d.	n.d.	0.35
Total	3.89	0.002	0.002	--	65.32
Acids (% by weight)					
C ₁ H ₂ O ₂	n.d.	0.018	0.0018	1.73	n.d.
C ₂ H ₄ O ₂	n.d.	0.070	0.0040	3.53	n.d.
C ₃ H ₆ O ₂	n.d.	0.013	0.0018	0.463	0.008
C ₄ H ₈ O ₂ iso	n.d.	0.009	n.d.	0.06	n.d.
C ₄ H ₈ O ₂	n.d.	0.003	n.d.	0.260	0.006
C ₅ H ₁₀ O ₂	n.d.	0.0005	n.d.	0.103	0.002
C ₆ H ₁₂ O ₂	n.d.	0.0001	n.d.	0.108	0.001
Total	n.d.	0.110	0.0076	6.157	0.017

n.d. : not determined

CLAIMS

1. A process for the treatment of the aqueous stream coming from the Fischer-Tropsch reaction comprising:
- feeding the aqueous stream containing the organic by-products of the reaction to a distillation or stripping column;
 - separation from the column of an aqueous stream enriched in alcohols having from 1 to 8 carbon atoms and other possible volatile compounds;
 - feeding the aqueous stream containing the organic acids leaving the bottom of the distillation column to an ion exchange step wherein said aqueous stream is put in contact with an anionic exchange resin bed and the production of two outgoing aqueous streams:
 - an aqueous stream (i) enriched in organic acids having from 1 to 8 carbon atoms;
 - a purified aqueous stream (ii) with a low content of organic acids.
2. The process according to claim 1, wherein the ionic exchange step comprises two or more anionic exchange resin beds situated in series and/or in parallel, with respect to the flow of the aqueous stream to be treated.
3. The process according to claim 1, wherein the aqueous stream enriched in alcohols has an alcohol concentration ranging from 25% by weight to 75% by weight; the

aqueous stream (i) enriched in organic acids, has a concentration of organic acids ranging from 3% by weight to 10% by weight and the purified aqueous stream (ii) with a low content of organic acids, has a concentration of organic acids lower than 0.01% by weight.

4. The process according to claim 1, wherein the aqueous stream coming from the Fischer-Tropsch reaction is first fed to the ion exchange step and the purified aqueous stream with a low content of organic acids (ii) leaving the ion exchange step is fed to the distillation column.

5. The process according to claim 1, wherein the aqueous stream is treated on a cationic exchange resin bed or a bed of chelating resin, in acid form, before contact with anionic exchange resins.

6. The process according to claim 1, wherein the anionic exchange resins are weak basic resins having at least one functional amine group.

7. The process according to claim 1, wherein the anionic exchange resins are in the form of a hydroxide (OH).

8. The process according to claim 1, wherein the anionic exchange resins are selected from resins with a styrene-divinyl benzene matrix or an acrylic-divinyl benzene matrix, having at least one functional amine group.

9. The process according to claim 1, wherein the ion

exchange step is carried out in a fixed bed reactor, wherein the aqueous stream is put in contact with the resin bed, at a space velocity of 1 BV/h to 10 BV/h and at a pressure sufficient for compensating the load drops
5 of the resin bed and at temperatures lower than 60°C.

10. The process according to claim 1, wherein the anionic exchange resin is regenerated by fluxing with an aqueous solution of a strong acid in an at least stoichiometric amount with respect to the anions of the
10 organic acids charged on the resin during the removal phase of the organic acids, with a space velocity of the regenerated aqueous solution of 0.5 BV/h to 20 BV/h, producing a stream enriched in organic acids and a resin bed in the form of a chloride; the resin is subsequently
15 fluxed with deionized water, then with a basic aqueous solution and again with deionized water, if necessary.

11. The process according to claim 10, wherein the strong acid is hydrochloric acid, the space velocity of the regenerating aqueous solution ranges from 1 BV/h to 5
20 BV/h and the basic aqueous solution is an aqueous solution of NaOH.

12. The process according to claim 1, wherein the cationic exchange resin is regenerated by fluxing with a basic aqueous solution, in such an amount that it is equal
25 to or exceeds the stoichiometric amount necessary for re-

generating the resin, interposing a washing phase between the removal phase of the organic acids and the regeneration of the resin, producing a stream of salified organic acids which is subjected to an electro dialysis treatment
5 in a bipolar configuration, to obtain an aqueous stream of organic acids and a basic aqueous stream to be recirculated as basic aqueous solution for the regeneration of the resin.

1/2

Fig. 1

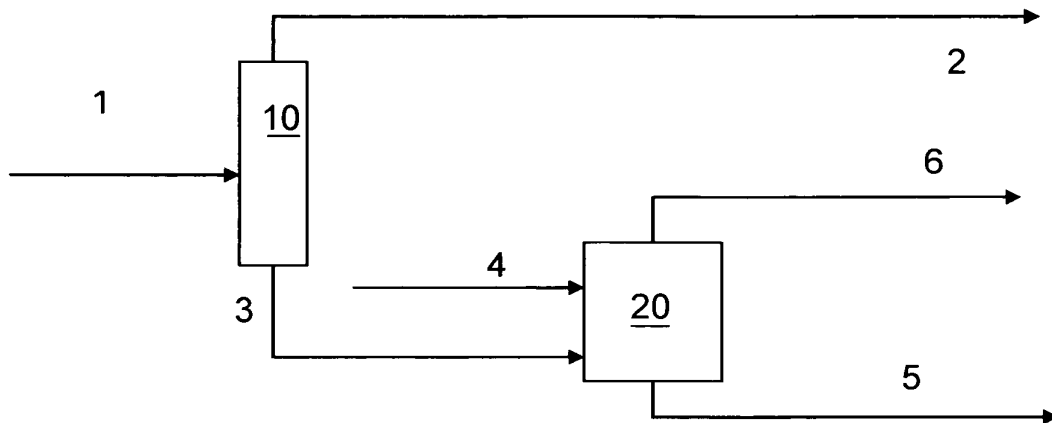

Fig. 2

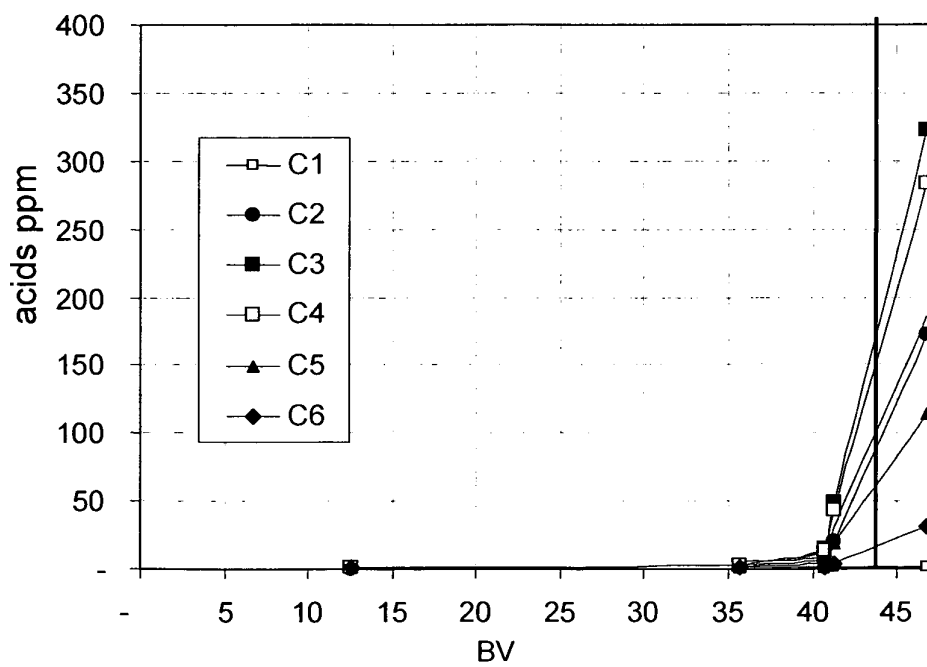

Fig. 3

