

April 21, 1970

J. L. DICKMANN

3,507,174

BACKUP TONG FOR POWER PIPE TONGS

Filed Dec. 4, 1967

5 Sheets-Sheet 1

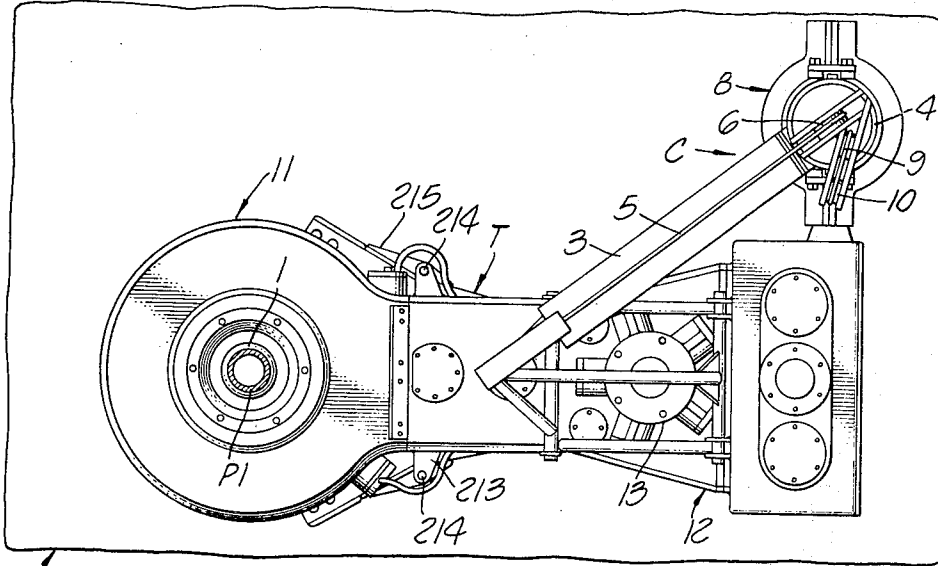

FIG. 1.

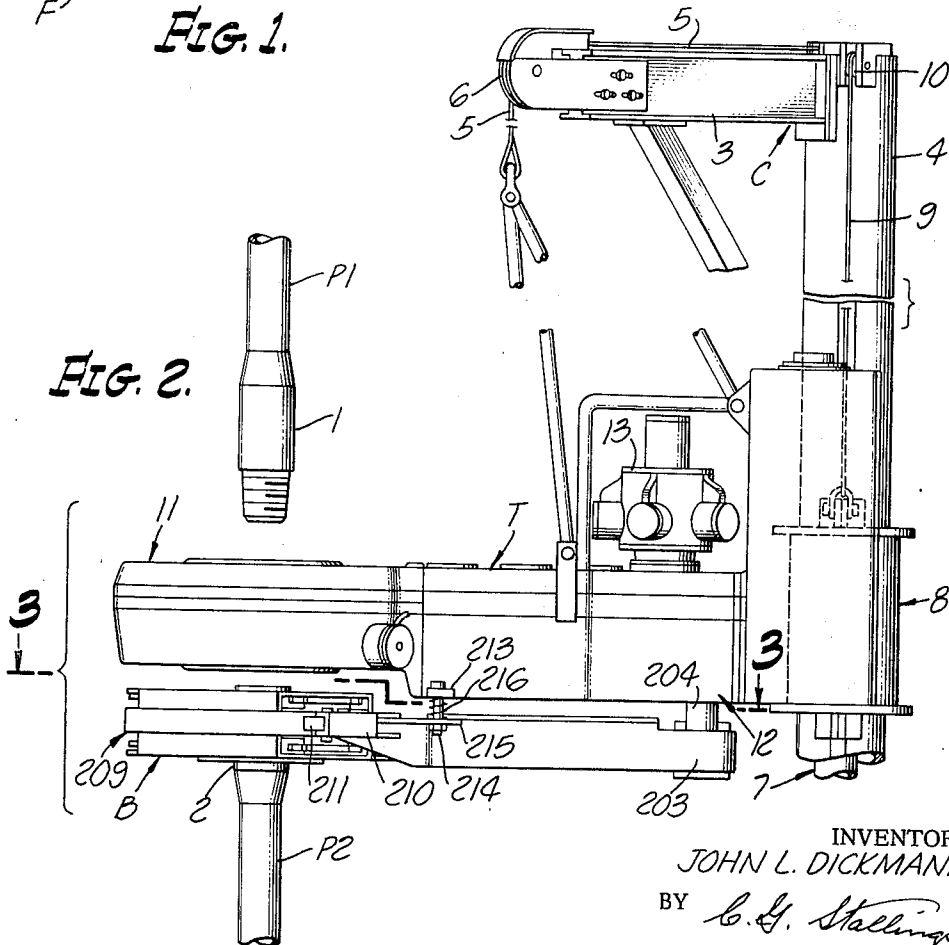

FIG. 2.

INVENTOR
JOHN L. DICKMANN
BY *C. G. Stallings*
ATTORNEY

April 21, 1970

J. L. DICKMANN

3,507,174

BACKUP TONG FOR POWER PIPE TONGS

Filed Dec. 4, 1967

5 Sheets-Sheet 2

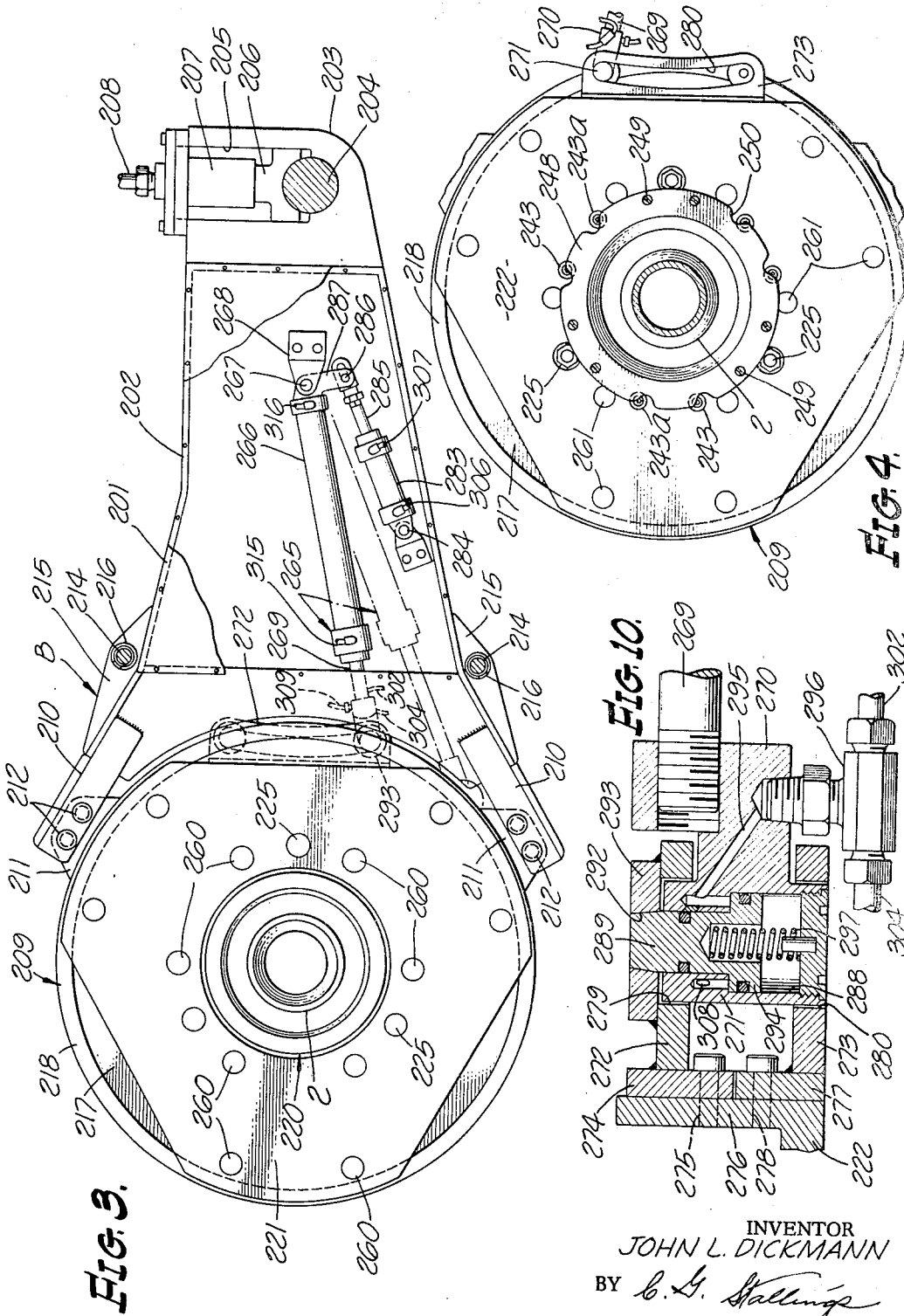

INVENTOR
 JOHN L. DICKMANN
 BY *b. G. Stallings*
 ATTORNEY

April 21, 1970

J. L. DICKMANN

3,507,174

BACKUP TONG FOR POWER PIPE TONGS

Filed Dec. 4, 1967

5 Sheets-Sheet 3

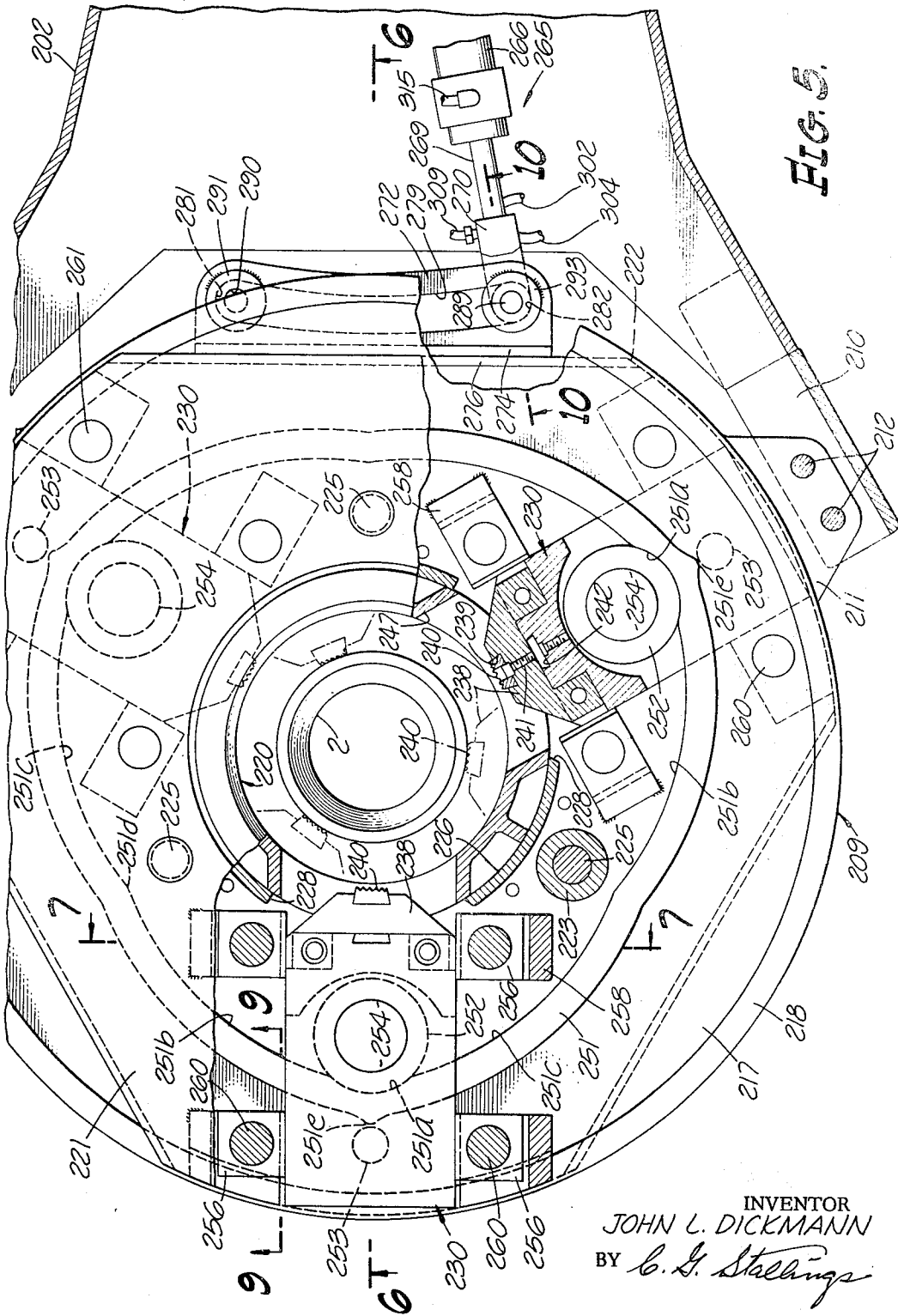

FIG. 5.

INVENTOR
JOHN L. DICKMANN
BY *C. S. Stallings*
ATTORNEY

April 21, 1970

J. L. DICKMANN

3,507,174

BACKUP TONG FOR POWER PIPE TONGS

Filed Dec. 4, 1967

5 Sheets-Sheet 4

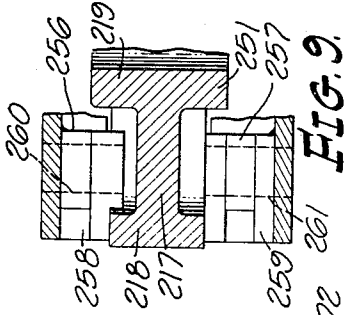

FIG. 9.

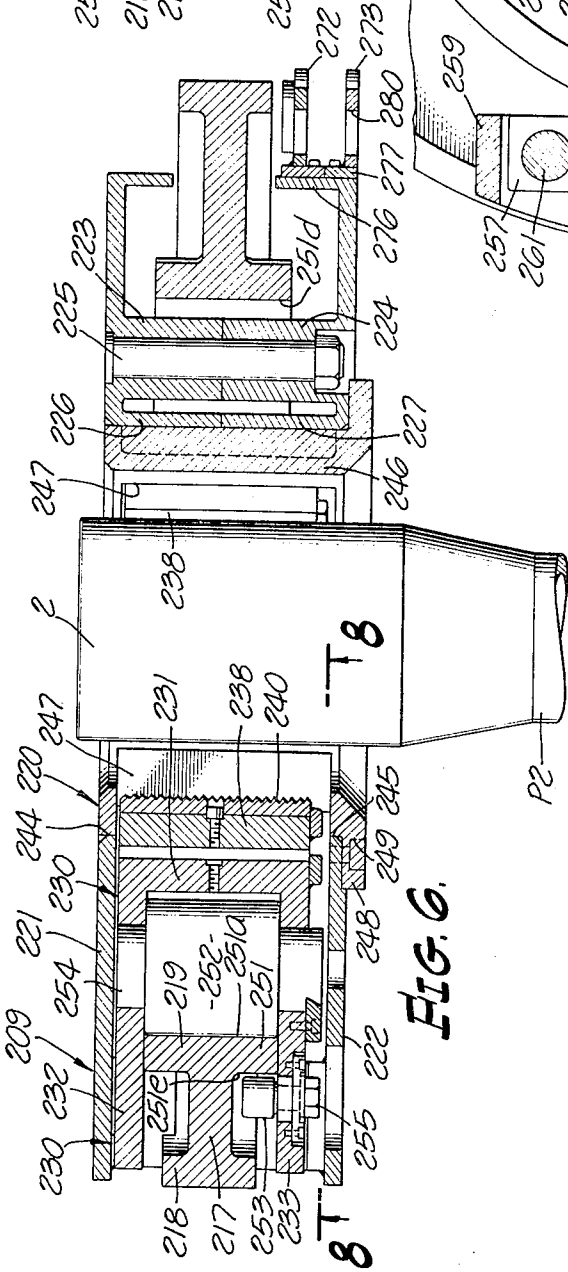

FIG. 6.

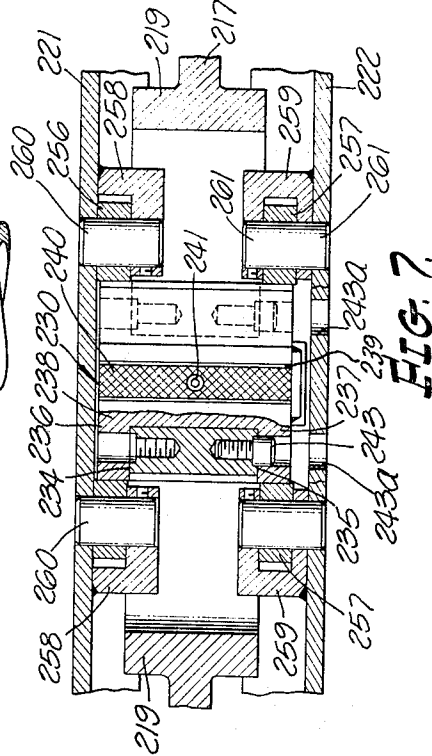

FIG. 7.

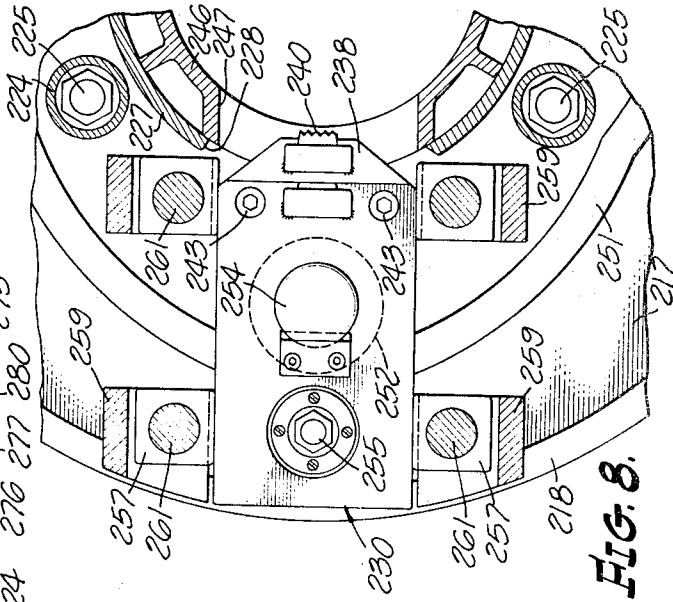

FIG. 8.

INVENTOR
 JOHN L. DICKMANN
 BY *C. A. Stallings*

ATTORNEY

April 21, 1970

J. L. DICKMANN

3,507,174

BACKUP TONG FOR POWER PIPE TONGS

Filed Dec. 4, 1967

5 Sheets-Sheet 5

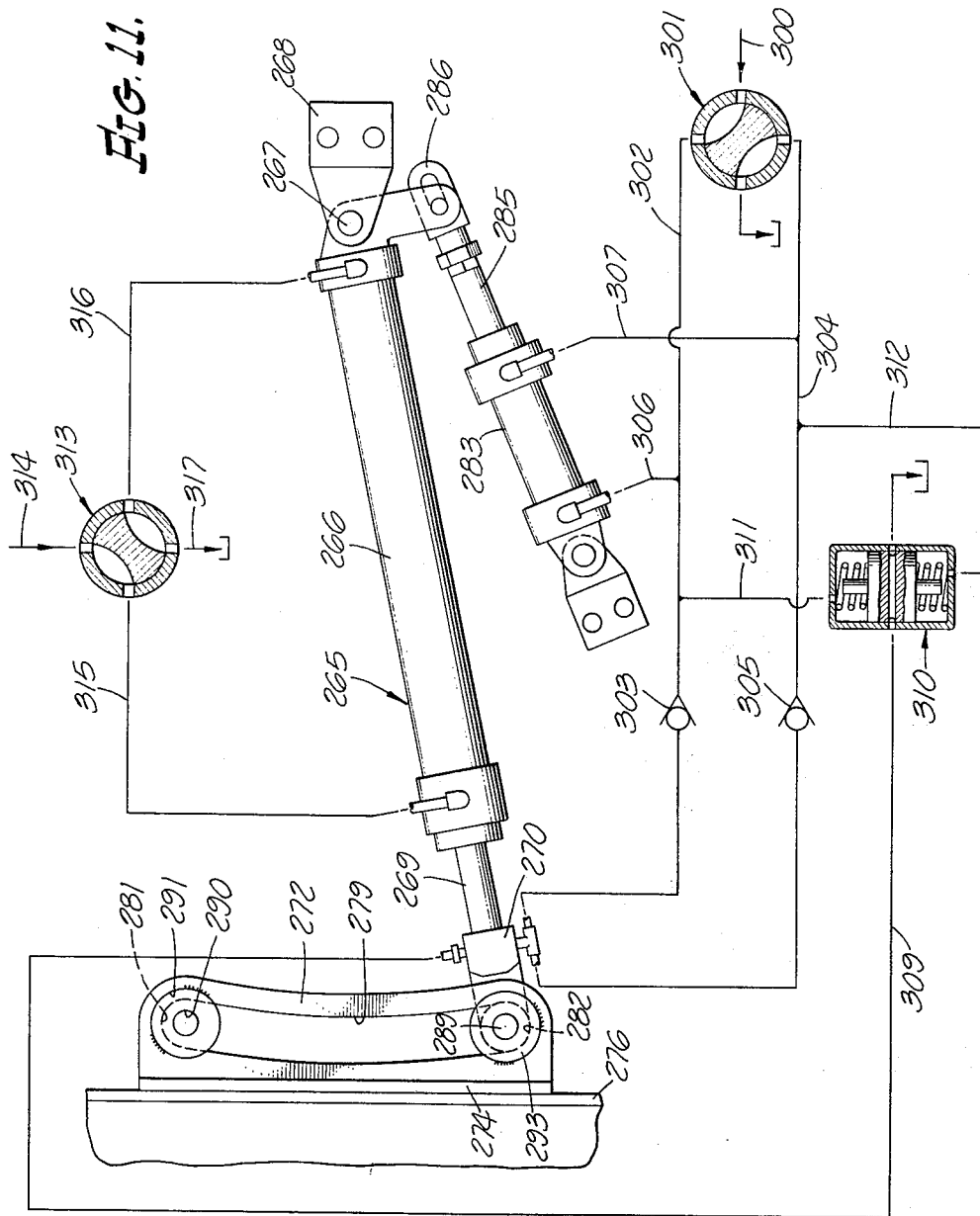

INVENTOR
JOHN L. DICKMANN
BY *C. S. Stallings*
ATTORNEY

1

2

3,507,174

BACKUP TONG FOR POWER PIPE TONGS

John L. Dickmann, Whittier, Calif., assignor to Byron Jackson Inc., Long Beach, Calif., a corporation of Delaware

Filed Dec. 4, 1967, Ser. No. 687,810

Int. Cl. B25b 17/00

U.S. Cl. 81—57.18

13 Claims

ABSTRACT OF THE DISCLOSURE

A backup tong for power well pipe tongs including pipe gripping jaws positively operable to grip pipe therebetween and positively retractable in response to rotation of a jaw carrying ring relative to a supporting structure, the supporting structure being supportable beneath a power-operated tong adapted to make up and break out pipe joints, one joint part of which may be gripped in the back-up tong, and a hydraulic cylinder being connected selectively to angularly spaced locations on the jaw carrying ring from a remote control point to enable actuation of the jaw carrying ring in opposite directions relative to the support structure.

Background of the invention

The present invention relates to pipe tongs, and more particularly to a pipe-gripping backup tong adapted to be employed in combination with a power driven tong, so that the parts of a joint of well pipe may be made up or broken out, the pipe-gripping means of the backup tong having application as well to other pipe tongs.

In the operation of power pipe tongs to make up and break out joints in well pipe, such as drill pipe, casing or tubing, all herein generally referred to as pipe, it is necessary that the length of pipe disposed in the well bore be held stationary during rotation of the length of pipe suspended in the derrick. While the length of pipe suspended in the derrick or the length of pipe disposed in the well bore may be rotated rapidly during the initial stages of making up the joint or in the latter stages of breaking out the joint, such rapid rotation being known as "spinning" and being accomplished either by rapid drive of a power-driven power tong or rapid rotation of the rotary table supporting the length of pipe in the well bore, it is necessary during the final stages of making up the pipe joint or during the initial stage of breaking out the pipe joint that the length of pipe disposed in the well bore be tightly held as high torque is applied by the power pipe tong either to finally make up the joint or initially break out the joint, as the case may be. Accordingly, it is the practice to employ a "backup" tong at least during the high torque stages of the operation of making up and breaking out the pipe joints, and such backup tongs have variously been conventional hand tongs secured to a post of the derrick by a cable, or backup tongs combined with the power tong which operates on the length of pipe supported in the derrick. It is desirable that the backup tong be quickly engageable with and releasable from the length of pipe disposed in the well bore so as to minimize loss of time and so as to eliminate the imposition of an axial force on the power driven tong and the backup tong, when such tongs are used in combination, which axial force is occasioned by the relative axial movement of the pipe joint as the threads are being rapidly relatively rotated during the spinning operation.

Summary

Accordingly, an object of the present invention is to provide a pipe gripping head applicable to backup tongs adapted to be employed in combination with a power

driven tong, in which the pipe-gripping means are adapted to be actuated into gripping engagement with the pipe as well as positively actuated out of gripping engagement with the pipe.

Another object of the invention is to provide pipe-gripping means for a backup tong assembly, or the like, in which the pipe-gripping means are jaws actuatable into pipe-gripping engagement with the pipe in response to rotation of a jaw carrying ring in either direction, the ring being operable by a pressure cylinder which is shiftable between a first position in which the cylinder will move the ring in one direction, and a second position at which the ring will move in the other direction.

Still another object of the invention is to provide a pipe tong assembly in which a pipe engaging jaw carrying ring is supported on a frame structure for relative angular movement, the frame structure having a cam ridge engageable by cam followers on the jaws, whereby the jaws will be actuated positively between a pipe engaging position and a retracted position in response to rotation of said jaw carrying ring in either direction, an actuator cylinder being selectively connectable to the jaw carrying ring at angularly spaced locations so as to effect movement of said jaws between said positions to cause said jaws to grip a pipe joint part to hold the same against rotation in either direction, whereby to enable the rotation of the other joint part in either direction to either make up or break out pipe joints.

A further object is to provide a tong assembly, as aforesaid, wherein latch means are provided for connecting the actuator cylinder to the spaced angular locations on the jaw carrying ring, said latch means being automatically released upon actuation of means for shifting the actuator cylinder between the angularly spaced locations, so that the changing of the direction of actuation of the jaw carrying ring may be effected from a remote location.

Other objects and advantages of the invention will be hereinafter described or will become apparent to those skilled in the art and the novel features of the invention will be defined in the appended claims.

Brief description of the drawings

FIG. 1 is a top plan view showing a power tong and backup tong assembly supported over a well bore;

FIG. 2 is a view in side elevation of the structure of FIG. 1;

FIG. 3 is an enlarged view, partly in top plan, with parts broken away, as taken on the line 3—3 of FIG. 2;

FIG. 4 is a fragmentary view in bottom plan showing the tong head of the invention;

FIG. 5 is an enlarged view, partly in top plan and partly in horizontal section, showing the tong head of the invention;

FIG. 6 is a vertical sectional view on a reduced scale, as taken on the line 6—6 of FIG. 5;

FIG. 7 is a fragmentary view in vertical section and on a reduced scale, as taken on the line 7—7 of FIG. 5;

FIG. 8 is a fragmentary view in horizontal section, as taken on the line 8—8 of FIG. 6;

FIG. 9 is a fragmentary view in vertical section, as taken on the line 9—9 of FIG. 5;

FIG. 10 is a fragmentary view in vertical section, as taken on the line 10—10 of FIG. 5; and

FIG. 11 is a schematic view illustrating the control system for effecting selective actuation of the jaw carrying ring.

Description of the preferred embodiment

Referring first to FIGS. 1 and 2, there is generally illustrated a tong assembly T adapted to be supported above the floor F of a drilling platform which may be part of the usual drilling rig mounted above a well bore and into

which pipe, such as drill pipe or casing, is adapted to be run and from which such pipe will be sometimes pulled, as in the case of drill pipe. Such a pipe is illustrated in FIGS. 1 and 2 as including an upper stand of pipe P1 in the illustrative form of a stand of drill pipe having a tool joint pin end 1 thereon adapted to be threadedly connected by the tong T to the box end 2 of a length or stand of the pipe P2 disposed in the well bore. In order to support the tong assembly T in an operative position above the well bore so that the stand of pipe P1 may be lowered therethrough for engagement with the pipe P2, a suitable crane C is provided, including a boom 3 projecting from a vertically disposed post 4. A cable 5 extends over sheaves 6, 6 and is connected to a pressure operated cylinder mechanism 7 disposed within the post 4, whereby the tong assembly T may be raised and lowered relative to the post 4 and thereby relative to the well bore into which or from which pipe is being removed. Also forming a part of the crane C is a rabbet 8 slidable vertically along the post 4, there being a second cable 9 also connected to the upper end of cylinder 7, extending over a sheave 10, and connected also to the rabbet 8 so that the mass of the tong assembly may be properly supported. This crane assembly may be of any desired type, but is preferably constructed as herein shown and in accordance with the disclosure in the application for United States Letters Patent filed concurrently herewith and entitled Power Tong Crane, Ser. No. 687,812.

The tong assembly, as is typical of tongs of the type here involved, includes a head section generally denoted at 11 and a supporting and power transmission section generally denoted at 12. The latter section in the illustrative embodiment has a hydraulic motor 13 adapted to be connected to a suitable source of motive fluid under pressure so as to drive the transmission mechanism of the tong assembly, which may be of any desired type, but which may preferably be constructed in accordance with the disclosure in the application for United States Letters Patent filed concurrently herewith and entitled Power Pipe Tong Transmission Assembly, Ser. No. 687,815. The head section 11 of the tong assembly T may be of any desired type of tong head mechanism adapted to grip and effect rotation of the pin end 1 of the pipe P1 while the box end 2 of the pipe P2 is held against rotation either in the usual rotary table slips or by the backup tong assembly generally denoted at B, made in accordance with the invention and hereinafter to be more fully described. The tong head 11 is preferably made in accordance with the disclosure in the application for United States Letters Patent filed concurrently herewith and entitled Pipe Tong Head, Ser. No. 687,830.

The backup tong assembly B, as best illustrated in FIGS. 2 and 3, includes a support structure 201 comprising an elongated hollow case 202 supported at its rear end 203 by a post 204 depending from the power tong assembly T. If desired, as will be appreciated by those skilled in the art, the post 204 may extend through a chamber 205 so as to be engaged by a pressure foot 206 of a force sensing hydraulic device 207 having a conduit 208 leading to a gauge which will show the angular force applied to the backup tong B tending to cause angular movement of the support structure 201, as an indication of the make up torque applied to pipe joints held by the backup tong, as will hereinafter be described, and rotated by the power tong assembly T.

At the forward end of the support structure 201 is a backup tong head assembly generally denoted at 209, the support structure 201 including brackets 210 connected to ears 211 formed as part of the head assembly 209 by bolts 212. This head end of the backup tong assembly is also, in the illustrative embodiment, supported beneath the power tong assembly T by means of ears 213 projecting from the sides of the tong assembly T and supporting bolts 214 which extend through outwardly

extended gussets 215 carried by the support structure 201, coiled springs 216 being provided between the gussets 215 and the ears 213 to cushion relative vertical movement between the head 11 of the power tong assembly T and the head 209 of the backup tong assembly B.

The tong head assembly 209, as seen in FIGS. 5 to 9 includes a member 217 which is in the form of a plate having an external marginal reinforcing flange 218 and an internal marginal flange 219, and the ears 211 previously described, by which the tong head 209 is carried at the head end of the support structure 201, being provided on the outer peripheral flange 218 of the plate member 217, so that the latter constitutes what will be characterized herein as a stationary ring. This stationary ring 217 supports a relatively rotatable ring assembly generally denoted at 220. The ring assembly 220 comprises an upper plate 221 and a lower plate 222 of generally triangular form, but truncated at the apices so as to generally conform to the circular form of the stationary plate 217. At a suitable number of angularly spaced locations the plates 221 and 222 are provided with opposing internal bosses 223 and 224 through which extend connecting bolts 225, and, at such locations, each of these plates may be further provided with axially extended arcuate flanges 226 and 227 which define therebetween radially opening windows 228 (see FIGS. 5 and 8).

The pipe gripping means comprise a plurality of jaws generally denoted at 230 which are adapted to be shifted through the windows 228 between retracted positions and inwardly projected positions at which the jaws 230 will engage a pipe joint part, such as the joint part 2 of the pipe P2. These jaws 230 each comprise a generally U-shaped body having an inner vertical end wall 231 and upper and lower walls 232 and 233, respectively, these latter walls extending radially into overlying and underlying relation to the stationary plate 217. The end wall 231 of each of the jaws 230 is, as best seen in FIGS. 5 and 7, provided with recesses 234 and 235, respectively, adapted to receive complementary ears 236 and 237 which project outwardly from the upper and lower ends of a die carrier 238, the latter having a vertically disposed slot 239 adapted to receive a pipe engaging tong die 240 of suitable construction, the tong dies respectively being held in the slots 239 by fasteners 241. It will also be noted that the end walls 231 of the jaws 230 are also provided with tong die slots 242 adapted to receive dies similar to the dies 240, but that die carriers 238 of different radial projection may be associated with the respective jaws 230 so as to enable the jaws to effectively engage pipe or pipe joints over a wide range of sizes, the illustrative die carrier 238 being adapted to engage an intermediate range of pipe sizes, while larger pipe sizes would be engaged by dies in the jaw slots 242 and the carriers 238 would be removed. In order to releasably secure the die carriers 238 on the end walls 231 of the jaws 230, the ears 237 of the die carriers are provided with openings adapted to accommodate locking screws 243 as seen in FIG. 7.

When the jaws 230 are fully retracted, it will be noted that the end walls 231 thereof would be radially outward from the inner periphery 244 of the top plate 221 and the inner periphery 245 of the bottom plate 222 of the rotatable ring assembly 220, but when a die carrier, such as the die carrier 238, is provided on the jaws 230 the die carriers will project radially inwardly relative to the peripheries 244 and 245 of plates 221 and 222, respectively. Thus, guide means are provided within the inner peripheries of the plates 221 and 222, including an annular body 246 having windows 247 adapted to register with the windows 228 provided between the inner walls 226 and 227 of the plates 221 and 222. The guide body 246 has an inner periphery which projects inwardly beyond the dies 240 in die carriers 238 so as to prevent engagement thereof by a pipe joint or pipe end. Beneath

the guide body 246 is an outwardly extended flange 248 adapted to be secured by fasteners 249 to the bottom plate 222 of the rotatable ring assembly 220. In order to substitute or remove the die carriers 238 from the jaws 230, as best illustrated in FIG. 4, the guide fasteners 249 must be removed to allow slight angular movement of the guide relative to the ring assembly 220, whereby to expose in guide flange notches 250 the fasteners 243 which secure the die carriers 238 to the jaw walls 231, but when the guide is in fastened position, the flange 248 at least partially overlies holes 243a in the bottom plate 222 of the ring assembly 220 which are aligned with the fasteners 243 so as to preclude loss of these fasteners from the assembly during use.

Means are provided for effecting the retraction and radial projection of the jaws 230 to pipe engaging positions. Such means includes a cam ridge 251 formed as at least the lower portion of the inner marginal flange 219 of the stationary plate 217, and a roller 252 engaged with one side of the ridge 251, as well as a roller 253, engaged with the other side of the ridge 251. The roller 252, in the illustrative embodiment, is a large roller disposed between the upper and lower walls 232 and 233 of the jaws 230 and rotatably supported on a shaft 254 extending between the latter walls. The roller 253 in each jaw is a smaller roller journalled on a stud 255 extending upwardly through the lower wall 233 of the jaw 230. As best seen in FIG. 5, the cam ridge 251 is a continuous ridge having three similar segments, each cooperative with the rollers 252 and 253 to effect movement of the respective jaws between the aforementioned retracted and inwardly projected positions. Each segment of the cam ridge 251 includes a central depression 251a and a pair of similar arcuately extended camming walls 251b and 251c extending arcuately from the central depression 251a. These walls 251b and 251c respectively merge with the walls 251c and 251b of the adjacent cam ridge segments at points designated 251d. In radial alignment with the central depressions 251a, each of the cam ridge segments is provided with an outwardly extended protuberance 251e, so that, as will be more fully understood hereinafter, the terminal stages of movement of the jaw carrying ring assembly 220 in a direction to cause retraction of the jaws will cause the rollers 252 to be seated in the central depressions 251a between the respective camming surfaces or walls 251b and 251c. In this connection, it will now be apparent that angular movement of the ring assembly 220 in either direction when the jaws 230 are in the positions shown in FIG. 5 will result in said jaws being cammed by the action of the rollers 252 on either cam wall 251b or cam wall 251c of the respective camming ridge segments inwardly towards a pipe located within the central opening of the tong head defined by the guide body 246. It will also be appreciated that reversal of the direction of angular movement of the jaw carrying ring 220 will effect retraction of the jaws 230 by the action of the rollers 253 on the outer walls of the respective camming ridge segments.

Inasmuch as the jaws 230 will project more or less inwardly into the tong head opening, depending upon the size of the pipe joint disposed therein, guide means are provided for the respective jaws, which guide means are adapted to cock slightly so as to maintain full facial contact with the jaws when torque applied to the pipe tends to cause cocking of the jaws within the guide means for the jaws. This guide means comprises, in association with each of the jaws 230, upper and lower guide pads 256 and 257, respectively, disposed in pad supports 258 and 259, a pivot pin 260 pivotally mounting the respective pads 256 and a pivot pin 261 pivotally mounting the respective pads 257 in their supports 258 and 259 for slight angular movement, these pads 256 and 257 slidably engage the jaws 230 along their side walls and each of the pads 256 and 257 may adjust angularly so as to maintain facial contact with the jaws as the latter are caused

to cock slightly angularly in response to engagement with the pipe when the latter is subjected to angular forces.

Actuator means generally denoted at 265 are provided for effecting angular movement of the jaw carrying ring assembly 220, as aforesaid, in opposite jaw closing directions, from the fully retracted jaw positions, as well as for effecting angular movement of the ring assembly 220 in opposite jaw retracting directions. This actuator means 265 includes a fluid pressure operated actuator cylinder 266 which is pivoted centrally of the support structure 201 and in rearwardly spaced relation to the head 209 on a pivot pin 267 supported in a bracket 268, as seen in FIG. 3. Projecting from the actuator cylinder 266 is an actuator rod 269 adapted to be connected to the ring assembly 220 at one location at one side of a center line extending from pivot pin 267 through the center of the tong head in order to force the ring assembly 220 in one angular jaw closing direction, and alternately, to be connected to the ring assembly 220 at the other side of said center line to cause angular movement of the ring assembly 220 in the other angular jaw closing direction, retraction of the rod causing reverse jaw opening angular movements of the ring assembly 220. As best seen in FIGS. 5 and 10, the rod 269 is connected to a block 270. This block 270 has a head 271 which is disposed between a pair of plates 272 and 273. Plate 272 is formed as part of, or connected to, a mounting bracket 274 which is secured as by fasteners 275 to an upwardly extending reinforcing side wall 276 extending along the margin of the lower plate 222 of the ring assembly 220. The plate 273 likewise is formed as part of, or connected to, a mounting bracket 277 which is secured as by fasteners 278 to the just-mentioned side wall 276. Plate 272 has an elongated arcuate slot 279, and plate 273 has a correspondingly elongated arcuate slot 280, in which vertical extensions of the head 271 of block 270 are disposed. The opposite ends of the slots 279 and 280, as indicated at 281 and 282 in FIG. 5, constitute abutments engageable by the head 271 to limit movement of said head relative to the plates 272 and 273. Means are provided for shifting the head 271 between the limits provided by the slot ends 281 and 282, including a fluid pressure operated actuator cylinder 283 pivotally supported at one end on a bracket 284, the cylinder 283 having a rod 285 connected by a pin-and-slot lost motion connection 286 to a lever arm 287 projecting from the pivoted end of the ring actuator cylinder 266. Accordingly, when rod 285 is retracted into cylinder 283, the actuator cylinder 266 will be caused to swing about its pivot 267 from the position shown in FIG. 3, at which the head 271 is engaged with the abutment 282, to the other end of the slots into engagement with the abutment 281. Conversely, when the actuator rod 285 is projected from the cylinder 283, opposite pivotal movement of the ring actuator cylinder 266 will occur. Thus, the actuator cylinder 283 and its rod 285 constitute means for shifting the ring actuator cylinder 266 to the above-mentioned opposite sides of the center line extending between pivot pin 267 and the center of the tong head 209. In addition, the lost motion connection 286 constitutes means enabling the ring actuator cylinder 266 to operate the move the ring assembly 220 in either direction without interference from the connection of the rod 285 to the lever arm 287, by which actuator cylinder 266 is caused to pivot between its two operative positions.

Means are provided for releasably latching the head 271 in its respective extreme positions. Accordingly, the head 271, as seen in FIG. 10, is provided with a bore 288 in which is disposed a latch pin 289, the upper end of which is adapted to extend into a pin opening 290 provided in a plate 291 mounted on the slotted plate 272 adjacent the abutment 281, when the head 271 is in that position. Adjacent the abutment 282 the latch pin 289 is adapted to engage in a pin opening 292 in a plate 293 carried by the slotted plate 272. Means are provided for retracting the pin 289 from the pin openings 290 and 292

and, in the illustrative embodiment, the pin 289 is provided with a piston portion 294 disposed in the bore 288; and the block 270 is provided with a fluid passage 295 leading from a fluid conduit connector 296, whereby fluid under pressure may be admitted to the bore 288 above the piston 294 to force the pin 289 downwardly against the force of a spring 297 which normally biases the pin 289 into latching engagement with either of the plates 291 or 293 when the head 271 is in either of the positions adjacent abutment 281 or 282.

Preferably, means are provided which may be controlled from a remote location, so that the latch pin 289 will be retracted when it is desired to actuate the actuator cylinder 283 to shift the ring actuator cylinder 266 between its two operative positions. Accordingly, as seen in FIG. 11, a control system is provided for supplying pressure to the pin retracting piston 294 when pressure is supplied to the actuator cylinder 283 at either end of the latter.

Referring to FIG. 11, such a system is illustrated diagrammatically as including a conduit 300 leading from a source of fluid pressure at a remote location to a 4-way valve 301. This 4-way valve may be suitably actuated as from a source of control fluid pressure to allow the flow of hydraulic fluid to the latch from chamber 288 (FIG. 10) through a conduit 302 having therein a back flow preventing valve 303, another conduit 304 also leading from the 4-way valve 301 to the pin retracting chamber 288 and having a back flow preventing valve 305 therein. A conduit 306 interconnects the conduit 302 to one end of the actuator cylinder 283, and a conduit 307 connects the conduit 304 to the other end of the actuator cylinder 283, so that, under the control of the 4-way valve 301, the actuating fluid pressure source conduit 300 may be selectively and simultaneously connected to one or the other ends of the bevel actuating cylinder 283 and to the latch pin retracting chamber 288. Normally, the latch pin chamber 288 communicates with an exhaust passage 308 provided in the head 271 of block 270, and this passage 308 communicates via a conduit 309 with a normally open exhaust valve 310. Accordingly, it is desired that when the latch pin is to be retracted the exhaust valve 310 be closed. For this purpose there is illustrated a conduit 311 connected to the conduit 302 and leading to the exhaust valve 310, and another conduit 312 is connected to the conduit 304 and leads to the exhaust valve 310, so that, upon the application of pressure to the latch pin chamber 288 through either of the conduits 302 or 304, the exhaust valve 310 is automatically closed; but when latch pin retracting pressure is relieved from conduits 302 or 304, the exhaust valve 310 will again automatically open so as to allow latch pin engaging spring 297 to force the latch pin to a latched position.

Also illustrated in FIG. 11 is a 4-way valve 313 adapted to effect opposite working of the double acting cylinder 266, whereby the ring assembly 220 is caused to be actuated in jaw closing and jaw opening directions. Leading into the valve 313 from a suitable remote source of fluid pressure is a conduit 314, and conduits respectively designated 315 and 316 are selectively adapted to communicate with the source conduit 314 to cause operation of the cylinder 266 in opposite directions, the other conduit 315 or 316 being connected to an exhaust conduit 317 leading back to the supply tank.

In the use of the tong assembly B described above in combination with a power tong assembly T, the latter will be operated to grip and rotate a joint of pipe, in say a right-hand direction, when a pipe joint is to be made up and during the initial stages of rotation of the pipe by the tong assembly T, the backup tong assembly B may remain idle. However, when the tool joints 1 and 2 shoulder, and the tong assembly B is employed to apply high torque forces to the pipe P1, it is then desired that the backup tong B be operated to resist rotation of the pipe P2 in a right-hand direction. Under these circumstances, the ring actuator cylinder 266 of the actuator means 265 should

be in the angular position shown in FIGS. 3 and 11, with the latch pin 289 connecting the actuator rod 269 to the jaw carrying ring assembly 220 so as to effect right-hand rotation of said ring assembly when pressure fluid is applied to the cylinder 266 to project the rod 269 therefrom. Such right-hand rotation of ring 220 will cause angular movement thereof relative to the stationary plate 217 and the cam ridge 251 formed on the latter, so that the jaw closing rollers 252 will progressively move along the cam walls 251b, forcing the jaws 230 toward one another into gripping engagement with the pipe joint 2. Thereafter, the tendency of the pipe P2 to rotate to the right with the pipe P1 will cause a corresponding tendency of the jaw carrying ring 220 to rotate to the right, thereby further energizing the camming action of the tong assembly and forcing the jaws 230 into tighter gripping engagement with the pipe P2.

Conversely, when the power tong assembly T is being employed to break out pipe joints by rotating the pipe P1 to the left, initial high torque loads will be imposed on the pipe joint and the backup tong B should be engaged with the joint 2 to prevent left-hand rotation thereof. Under these circumstances, the operator will effect release of the latch pin 289 and will cause the application of fluid pressure to the actuator cylinder 283 to retract rod 285, thereby shifting the ring actuator cylinder 266 over-center into engagement with the abutment 281, whereupon the latch pin 289 may be re-engaged by the spring 297. Then, application of fluid pressure to the cylinder 266 will cause left-hand rotation of the jaw carrying ring 220 which will cause movement of the rollers 252 along cam surfaces 251c, thereby effecting closure of jaws 230 on the pipe joint 2. Any tendency of the joint part 2 to rotate to the left along with the pipe P1 will again effect self-energization of the backup tong, whereby the jaws will be more firmly forced into gripping engagement with the joint part 2.

Following either of the above described jaw engaging operations, the backup tong jaws 230 will be positively retracted in response to retraction of the rod 269 in the ring actuator cylinder 266. In this connection, the ring assembly 220 will be pulled by rod 269 in the jaw opening direction and the rollers 253 engaging the outer face of the cam ridge 251 will effect positive jaw retraction, these rollers, in their final stage of movement, engaging the protuberances 251e on the cam ridge 251 to seat the rollers 252 in the central depressions 251a between cam ridges 251b and 251c.

I claim:

1. Tong apparatus for making up and breaking out joints in well pipe, said joints being composed of threaded pipe parts, a support structure, pipe engaging means carried by said support structure for relative angular movement thereof, means for effecting such angular movement, said pipe engaging means including a ring, jaws carried by said ring and movable between pipe engaging and retracted positions, means for moving said jaws between said positions in response to angular movement of said ring in opposite directions, said last-mentioned means comprising a cam ridge on said support structure, having inner and outer cam surfaces and cam follower means on said jaws engaged with said inner and outer cam surfaces of said cam ridge for camming said jaws to both of said positions upon angular movement of said ring in opposite directions.

2. Tong apparatus as defined in claim 1, wherein said cam ridge comprises similar cam ridge segments engageable by said cam followers of the respective jaws upon movement of said ring in either direction for camming said jaws toward a pipe gripping position.

3. Tong apparatus as defined in claim 1, wherein said support means comprises a central plate having said cam ridge thereon, said ring comprising upper and lower plates rotatable relative to said central plate, said jaws being carried between said upper and lower plates, and

said follower means includes rollers carried by said jaws and engaged with opposite sides of the said cam ridge.

4. Tong apparatus as defined in claim 1, wherein said ring comprises upper and lower plates, said jaws being slidably disposed between said plates, said plates having means slidably guiding said jaws for radial movement relative to said ring, including pivoted pads for allowing said jaws to cock relative to said means slidably guiding said jaws.

5. Tong apparatus as defined in claim 1, wherein said pipe engaging means includes a ring, said means for effecting angular movement of said pipe engaging means comprising an actuator cylinder carried by said support structure and connected to said ring for moving the same angularly in opposite directions, said actuator means being pivotally connected to said support structure and including means for shifting the connection of said actuator means to said ring from one side of a center line extending through said ring and said pivotal connection to the other side of said center line.

6. Tong apparatus as defined in claim 5, wherein said means for shifting said actuator includes second actuator means and means providing a lost motion connection interconnecting said second actuator means to said first-mentioned actuator means.

7. In tong apparatus for making up and breaking out joints of well pipe, a support structure, a stationary member carried by said support structure, a member movable rotatively relative to said stationary member, jaws carried by said movable member, means for effecting movement of said jaws between pipe gripping positions and retracted positions responsive to rotation of said movable member between first and second positions in either direction, operator means including a pressure operated cylinder for actuating said movable member in opposite directions, pivot means connecting said actuator cylinder to said support structure at one end, and means for selectively connecting the other end of said actuator cylinder to said movable member at locations at opposite sides of a center line extending from said pivot means through the center of said movable member for selectively moving said movable member in either direction between said first and second positions.

8. Tong apparatus as defined in claim 7, wherein said operator means includes a second actuator cylinder connected to said first-mentioned actuator cylinder for moving the latter between positions at which said other end of said first-mentioned actuator is connectable to said movable member at said positions.

9. Tong apparatus as defined in claim 8, wherein said first-mentioned actuator has a lever thereon and including lost motion means connecting said second actuator cylinder to said lever for allowing free movement of said

lever when said movable member moves between said first and second positions.

10. Tong apparatus as defined in claim 7, wherein said means for selectively connecting said other end of said actuator cylinder to said movable member comprises a head carried by said actuator cylinder, a latch pin carried by said head, a pair of latch plates on said movable member, guide means for guiding said latch head between said latch plates when said latch pin is disengaged from said latch plates, and including means for causing movement of said head along said guide means between positions at which said latch pins are engageable with said latch plates.

11. Tong apparatus as defined in claim 7, wherein said means for selectively connecting said other end of said actuator cylinder to said movable member comprises a head carried by said actuator cylinder, a latch pin carried by said head, a pair of latch plates on said movable member, guide means for guiding said latch head between said latch plates when said latch pin is disengaged from said latch plates, including means for causing movement of said head along said guide means between positions at which said latch pins are engageable with said latch plates, and means for retracting said latch pins from said latch plates at said positions.

12. Tong apparatus as defined in claim 10, wherein said means for causing said movement of said head includes a fluid pressure operated actuator, and said means for retracting said latch pins includes a fluid pressure operated actuator.

13. Tong apparatus as defined in claim 12, wherein means are provided for applying fluid pressure to said actuator for said latch pin when fluid pressure is supplied to said actuator for causing said movement of said head.

References Cited

UNITED STATES PATENTS

2,618,468	11/1952	Lundeen	81-57
2,737,839	3/1956	Paget	81-53
2,760,392	8/1956	Paget	81-53
2,846,909	8/1958	Mason	81-53
2,871,743	2/1959	Kelley	81-53
2,933,961	4/1960	Adams	81-53
2,950,639	8/1960	Mason	81-53
3,180,186	4/1965	Catland	81-57
3,261,241	7/1966	Catland	81-57
3,380,323	4/1968	Campbell	81-54

JAMES L. JONES, JR., Primary Examiner

U.S. Cl. X.R.

81-57.21