

(19)
(12)

(KR)
(A)

(51) 。 Int. Cl.7
F16H 61/06

(11)
(43)

10-2004-0015401
2004 02 19

(21) 10-2002-0047481
(22) 2002 08 12

(71) 231

(72) 2 1178-24

(74)
:

(54)

, ;
, ,
, .

1

1 N

2 D .

3 R .

(202)

(206)
(208)

(204)

(S1)

(208)

(210)

(212)

(204)
(212)

(210)
(214)

(S2)

(S2)

(216)

(218)

1 (2) (6) (8) (10) (S1) (12) (4) (10) (14) (S2) (S2) (4) (12) (20) (4) (20) (24) (12) D (26) (12) (22) (28) (2) (30) (32) (34) (36) (38) (40) (42)가 (44) (46) (48) (50) (52) 가 (54) (56) (58) (60) (62) (64) (66) (68) (70) (72) (74) (76) (78) (80) (82) (84) (86) (88) (90) (92) (94) (96) (98) (100) (102) (104) (106) (108) (110) (112) (114) (116) (118) (120) (122) (124) (126) (128) (130) (132) (134) (136) (138) (140) (142) (144) (146) (148) (150) (152) (154) (156) (158) (160) (162) (164) (166) (168) (170) (172) (174) (176) (178) (180) (182) (184) (186) (188) (190) (192) (194) (196) (198) (200) (202) (204) (206) (208) (210) (212) (214) (216) (218) (220) (222) (224) (226) (228) (230) (232) (234) (236) (238) (240) (242) (244) (246) (248) (250) (252) (254) (256) (258) (260) (262) (264) (266) (268) (270) (272) (274) (276) (278) (280) (282) (284) (286) (288) (290) (292) (294) (296) (298) (300) (302) (304) (306) (308) (310) (312) (314) (316) (318) (320) (322) (324) (326) (328) (330) (332) (334) (336) (338) (340) (342) (344) (346) (348) (350) (352) (354) (356) (358) (360) (362) (364) (366) (368) (370) (372) (374) (376) (378) (380) (382) (384) (386) (388) (390) (392) (394) (396) (398) (400) (402) (404) (406) (408) (410) (412) (414) (416) (418) (420) (422) (424) (426) (428) (430) (432) (434) (436) (438) (440) (442) (444) (446) (448) (450) (452) (454) (456) (458) (460) (462) (464) (466) (468) (470) (472) (474) (476) (478) (480) (482) (484) (486) (488) (490) (492) (494) (496) (498) (500) (502) (504) (506) (508) (510) (512) (514) (516) (518) (520) (522) (524) (526) (528) (530) (532) (534) (536) (538) (540) (542) (544) (546) (548) (550) (552) (554) (556) (558) (560) (562) (564) (566) (568) (570) (572) (574) (576) (578) (580) (582) (584) (586) (588) (590) (592) (594) (596) (598) (600) (602) (604) (606) (608) (610) (612) (614) (616) (618) (620) (622) (624) (626) (628) (630) (632) (634) (636) (638) (640) (642) (644) (646) (648) (650) (652) (654) (656) (658) (660) (662) (664) (666) (668) (670) (672) (674) (676) (678) (680) (682) (684) (686) (688) (690) (692) (694) (696) (698) (700) (702) (704) (706) (708) (710) (712) (714) (716) (718) (720) (722) (724) (726) (728) (730) (732) (734) (736) (738) (740) (742) (744) (746) (748) (750) (752) (754) (756) (758) (760) (762) (764) (766) (768) (770) (772) (774) (776) (778) (780) (782) (784) (786) (788) (790) (792) (794) (796) (798) (800) (802) (804) (806) (808) (810) (812) (814) (816) (818) (820) (822) (824) (826) (828) (830) (832) (834) (836) (838) (840) (842) (844) (846) (848) (850) (852) (854) (856) (858) (860) (862) (864) (866) (868) (870) (872) (874) (876) (878) (880) (882) (884) (886) (888) (890) (892) (894) (896) (898) (900) (902) (904) (906) (908) (910) (912) (914) (916) (918) (920) (922) (924) (926) (928) (930) (932) (934) (936) (938) (940) (942) (944) (946) (948) (950) (952) (954) (956) (958) (960) (962) (964) (966) (968) (970) (972) (974) (976) (978) (980) (982) (984) (986) (988) (990) (992) (994) (996) (998) (1000)

(57)

1.

, , , , .

2.

1 ,

1

3.

1 2 ,

D

1 ,

4

3 ;

3 2 ,

1

2 ,

3

2

1 ,

2

3

4 ,

3

3

가

4.

1 ,

1

1

2

4

2

1

2

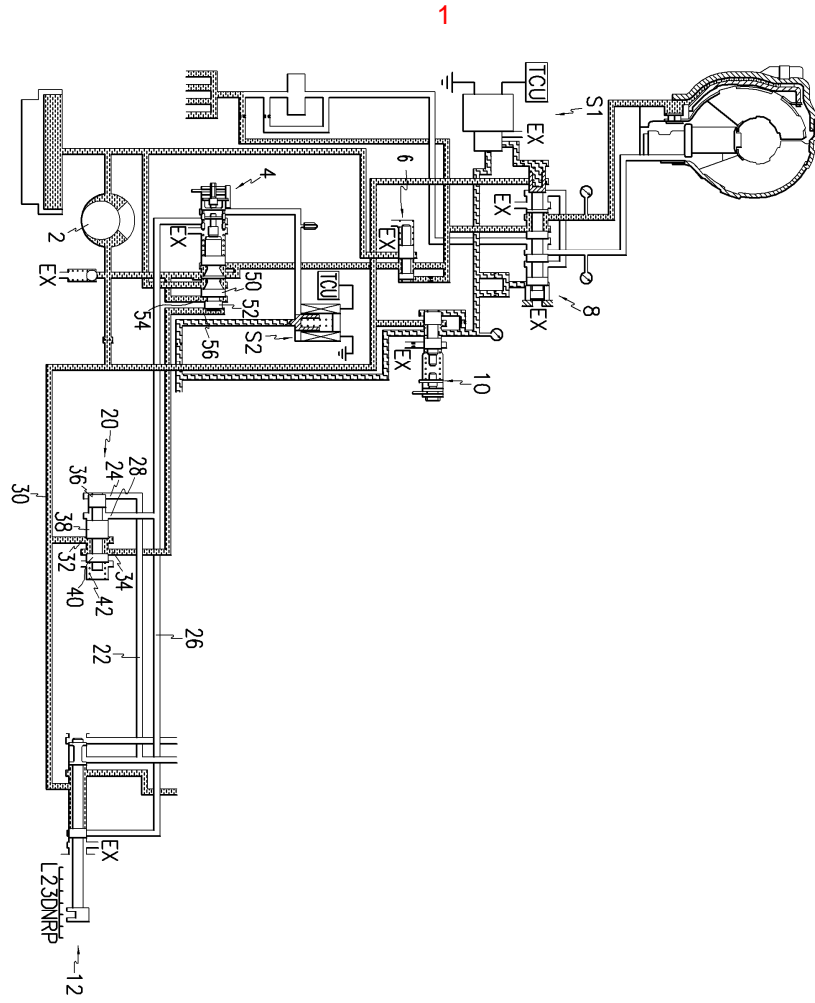

2

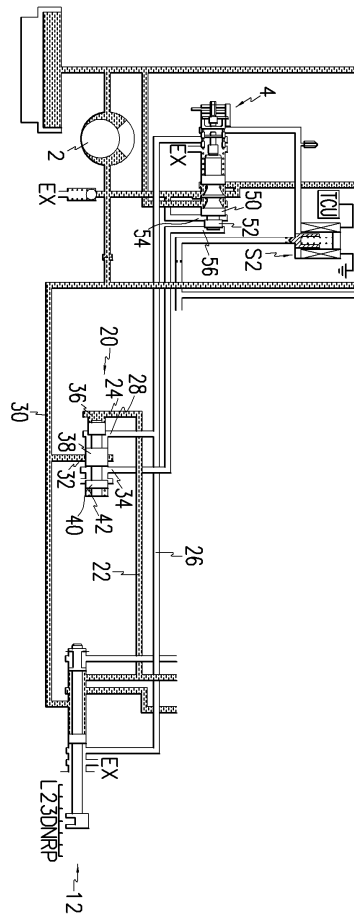

3

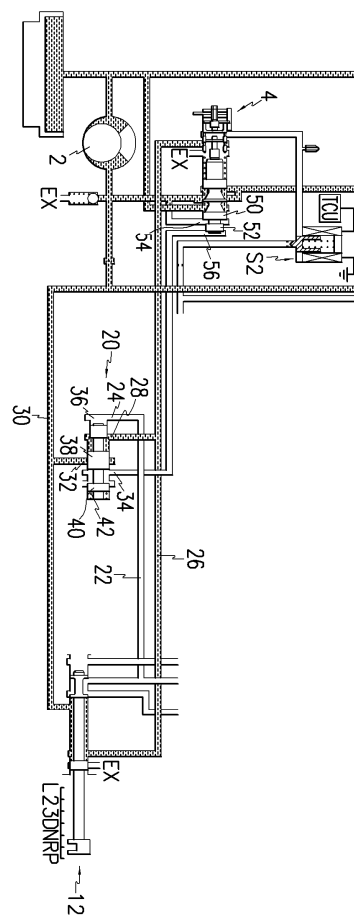

4

