

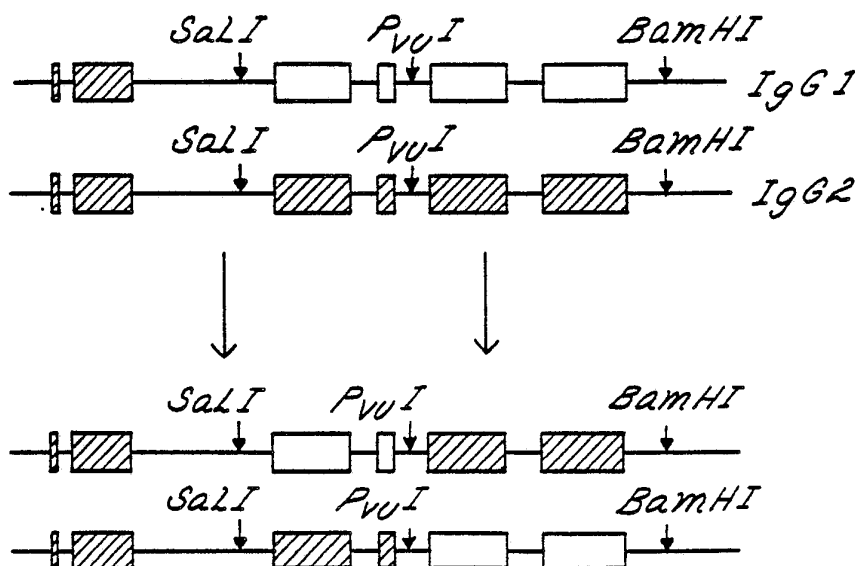

INTERNATIONAL APPLICATION PUBLISHED UNDER THE PATENT COOPERATION TREATY (PCT)

<p>(51) International Patent Classification<sup>4</sup> : C12N 15/00, C12P 21/00 C07K 15/00</p>	<p>A1</p>	<p>(11) International Publication Number: <b>WO 89/ 07142</b> (43) International Publication Date: 10 August 1989 (10.08.89)</p>
<p>(21) International Application Number: PCT/US89/00297 (22) International Filing Date: 24 January 1989 (24.01.89) (31) Priority Application Number: 152,741 (32) Priority Date: 5 February 1988 (05.02.88) (33) Priority Country: US  (71)(72) Applicants and Inventors: MORRISON, Sherie, L. [US/US]; 31 Claremont Road, Scarsdale, NY 10583 (US). OI, Vernon, T. [US/US]; 316 Waverly, #3, Menlo Park, CA 94025 (US).  (74) Agent: NEELEY, Richard, L.; Leydig, Voit &amp; Mayer, 350 Cambridge Avenue, Suite 200, Palo Alto, CA 94306 (US).</p>		<p>(81) Designated State: JP.  <b>Published</b> <i>With international search report. Before the expiration of the time limit for amending the claims and to be republished in the event of the receipt of amendments.</i></p>

(54) Title: DOMAIN-MODIFIED CONSTANT REGION ANTIBODIES



(57) Abstract

An antibody having at least one binding site region and a domain-modified constant region is provided wherein the domain-modified constant region is a substitution, duplication, or deletion of substantially all of the amino acids of at least one of the domains of the constant region. The functional properties of the domain-modified constant region antibodies are altered to enhance the desired biological functions for a particular application. DNA sequences encoding constructs expressing domain-modified constant region antibody heavy chains and cells expressing domain-modified constant region antibodies are also provided.

***FOR THE PURPOSES OF INFORMATION ONLY***

Codes used to identify States party to the PCT on the front pages of pamphlets publishing international applications under the PCT.

AT	Austria	FR	France	ML	Mali
AU	Australia	GA	Gabon	MR	Mauritania
BB	Barbados	GB	United Kingdom	MW	Malawi
BE	Belgium	HU	Hungary	NL	Netherlands
BG	Bulgaria	IT	Italy	NO	Norway
BJ	Benin	JP	Japan	RO	Romania
BR	Brazil	KP	Democratic People's Republic of Korea	SD	Sudan
CF	Central African Republic	KR	Republic of Korea	SE	Sweden
CG	Congo	LI	Liechtenstein	SN	Senegal
CH	Switzerland	LK	Sri Lanka	SU	Soviet Union
CM	Cameroon	LU	Luxembourg	TD	Chad
DE	Germany, Federal Republic of	MC	Monaco	TG	Togo
DK	Denmark	MG	Madagascar	US	United States of America
FI	Finland				

## DOMAIN-MODIFIED CONSTANT REGION ANTIBODIES

5

INTRODUCTIONTechnical Field

The present invention relates to monoclonal antibodies and in particular to genetically modified monoclonal antibodies having domain-modified constant regions.

Background of the Invention

Naturally occurring specific binding molecules, such as immunoglobulins, enzymes, and membrane proteins, have seen an extraordinary expansion in commercial applications over the last decade. With the advent of monoclonal antibodies, the usefulness of immunoglobulins has been greatly expanded. However, in many applications, the use of monoclonal antibodies is severely restricted where the monoclonal antibodies are to be used in a biological environment. For example, monoclonal antibodies produced in rodents, e.g., mice, the most common producer species, are immunogenic to other species.

25

Cross-species immunogenicity is a function of the constant region of immunoglobulins. The constant region has a number of specific functions, such as complement binding, cell receptor binding control of catabolic rate, anaphylaxis, opsonization, placental and gut transfer, and immune regulation, in addition to being immunogenic. There will, therefore, be situations where it will be desirable to have constant regions which bind to cells or proteins from a particular species together with binding regions (variable regions) specific for a particular antigen.

35

Although it has generally been relatively easy to produce murine monoclonal antibodies of the desired antigen specificity, it has been much more difficult to produce human monoclonal antibodies with the desired constant region properties. Human monoclonals are preferable for many applications, especially in vivo diagnosis and therapy of humans. Chimeric antibodies with antigen specificity derived from a mouse myeloma cell or a hybridoma have been joined to human constant regions to overcome, in part, species limitations inherent in monoclonal antibodies. Genetically engineered antibodies produced by transfectomas have also allowed investigators to change the isotype of the antibody that results following fusion to a normal spleen cell, usually to produce IgG antibodies.

However, there have been obstacles encountered in using transfectomas to produce chimeric antibodies having murine variable regions and human constant regions. For example, initially-produced chimeric antibodies were limited to those in which the constant region had all of the properties of the donor human constant region. Enhanced or reduced properties, such as binding of complement, are desirable for many applications.

Accordingly, considerable interest remains in preparing immunoglobulins having modified biological functions while retaining the broad range of binding specificity available by use of variable regions from an easily available source.

#### Relevant Literature

Oi et al., Proc. Natl. Acad. Sci. USA (1983) 80:825-829; Morrison et al., Proc. Natl. Acad. Sci. USA (1984) 81:6851-6855; Ochi et al., Proc. Natl. Acad. Sci. USA (1983) 80:6351-6355; and Ochi et al., Nature (London) (1983) 302:340-342 describe immunoglobulin expression in transfectomas. Neuberger et al., Nature

(London) (1985) 314:268-270 and Bouhane et al., Nature (London) (1984) 312:643 describe transfectomas secreting antibodies having mouse variable and human constant regions. Neuberger et al., Nature (London) (1984) 312: 5 604-608 describe the expression of antigen binding domains covalently associated with non-immunoglobulin sequences. Advances in Immunology, Vol 40, pp. 61-134 reviews biologic activities residing in the Fc region of Ig. Immunoglobulin genes are disclosed and reviewed 10 in numerous publications, such as Watson et al., Molecular Biology of the Gene, Vol. II, Benjamin/Cummings, Menlo Park, California, 4th edition, 1987, Chapter 23, and the publications cited therein.

15

#### SUMMARY OF THE INVENTION

An antibody having at least one binding site region and a domain-modified constant region is provided. The domain modification is either a substitution of, an insertion of, or a deletion of substantially all 20 of the amino acids of at least one of the domains of a constant region: C<sub>L</sub>, C<sub>H</sub>1, hinge, C<sub>H</sub>2, C<sub>H</sub>3 or C<sub>H</sub>4. The functional properties of the domain-modified constant region antibodies are selected to enhance the desired biological functions for a particular application.

25 Antibody constant-region domains can be eliminated, inserted, or substituted for (exchanged) by a domain of a different isotype or immunoglobulin class or from the light chain. The substituted or inserted domain can be from the same antibody or from another antibody of the 30 same animal, the same species of animal, or a different species of animal. In this way, the functional properties of the biological molecule can be optimized for the desired application.

35 DNA constructs encoding domain-modified constant regions, constructs encoding complete constant-region-domain-modified antibodies, and cells expressing such antibodies are also provided.

BRIEF DESCRIPTION OF THE DRAWINGS

Figure 1 illustrates a cloning cassette used to exchange constant regions;

5           Figure 2 illustrates a cloning cassette used to exchange constant region domains;

Figure 3 illustrates a cloning cassette used to delete or duplicate constant region domains;

10           Figure 4 illustrates a cloning cassette used to delete a carboxy terminal domain; and

Figure 5 illustrates two variations of cloning cassettes used to delete an amino terminal domain.

DESCRIPTION OF THE SPECIFIC EMBODIMENTS

15           Novel methods and compositions are provided for production of antibodies having domain-modified constant regions. The present invention is concerned specifically with modifications of one or more domains of the constant region of an antibody, which can be or  
20           is attached to a binding-site or variable region of the original antibody from which the constant region was derived or to another antibody. The complete antibodies have at least one binding site region which may be  
25           naturally occurring in a host animal or genetically modified. Alterations of the binding site region of the antibodies do not constitute a part of this invention, although such altered-binding-site antibodies will be within the scope of this invention if their  
30           constant regions are modified as described herein.

35           As used herein, a domain-modified constant region means that substantially all of the amino acids of at least one of the domains of C<sub>L</sub>, C<sub>H</sub>1, hinge, C<sub>H</sub>2, C<sub>H</sub>3 or C<sub>H</sub>4 in an antibody chain is either deleted, inserted or exchanged. By exchanged is meant that a domain from  
a different source is substituted for a domain initially present in the antibody. When the modification is a substitution, usually the domain is substituted for by

the equivalent domain of an antibody of another isotype or class or from the light chain of the same or a different antibody. Usually the insertion of a domain is the duplication of one or more domains of the original antibody. However, other substitutions and/or duplications can also be carried out.

Antibodies having a domain-modified constant region can be prepared from fused genes containing a gene segment encoding a portion of the antibody involved with binding and a gene segment encoding a domain-modified constant region derived from the same or a different host animal. Two expression cassettes, one encoding the heavy chain and one encoding the light chain, are generally involved in producing complete domain-modified constant region antibodies, which genes are introduced into an appropriate eukaryotic host under conditions for expression and processing. When the genes are expressed and the antibody chains bind together, an assembled antibody is obtained. The antibodies include IgM, IgG, IgA, IgD and IgE classes as well as the various subclasses of the individual classes (e.g, human IgG1 through IgG4). Chain types include for the light chain  $\kappa$  or  $\lambda$  and for the heavy chain  $\mu$ ,  $\gamma$ ,  $\alpha$ ,  $\delta$  and  $\epsilon$ . Classification by isotype refers to the class and subclass, light chain type and subtype, and can also be applied to the variable region groups and subgroups. An example of an isotype designation for a mouse immunoglobulin is IgG<sub>2a</sub>( $\kappa$ ).

The binding site or variable region will vary in conformation with the amino acid sequence providing the desired specificity. The variable region of the immunoglobulins will be derived from a convenient source, usually mammalian, which may be a rodent, e.g., mouse or rat, rabbit, or other vertebrate, mammalian or otherwise, capable of producing immunoglobulins. The variable region may be genetically modified or naturally occurring.

The constant region of the immunoglobulin, as well as the J chain for IgM (not the same as the J region of the heavy or light immunoglobulin chain), will be derived from a vertebrate source the same as or different from the source of the variable region, particularly a mammalian source, more particularly primate or domestic animal, e.g., bovine, porcine, equine, canine, feline, or the like, and most particularly human. The source of the constant region can be either from the same animal or different animals of the same or different species as the source of the variable region.

As is known, the constant region of an antibody chain is specific for a species. Within each class there will be a plurality of allotypes. The domain-modified constant-region portion of the antibody will normally be chosen in accordance with the intended uses of the antibody. As a first consideration where the antibody is to be introduced into a host animal for diagnosis or therapy, the constant or immunogenic portion will be selected so as to minimize the immune response of the host. Thus frequently, the source of the constant region is human when intended for use in humans.

The potential application of antibody molecules are determined not only by their antigen specificity but also by their effector functions. Therefore, as a second consideration, the domain-modified antibodies are selected to optimize their ability to perform a particular function. For example, the domain or domains related to enhancing the half-life of the antibodies will be modified to provide an enhanced or shortened half-life depending on the particular application. Other functions that can be selectively modified in antibodies using the techniques taught herein include tissue distribution, ability to fix complement, and ability to participate in antibody-dependent cellular cytotoxicity.



As a third consideration, the antibodies are modified to facilitate in vitro manipulations. For example, antibodies can be altered so that it is easier to add more molecules of a radioactive isotope or drug without changing the binding site specificity. If the antibody is to function as a drug delivery system, enhancing covalent attachment of the drug in an antibody that can be secreted in large quantities would be desirable.

The modification of the constant region can be the deletion, insertion, or substitution of substantially all of the amino acids of at least one domain. "Substantially all," when referring to the amino acids of a domain, encompasses 100% of the amino acids being manipulated but can also refer to less than 100% of the amino acids, such as 80%, 85%, 90%, or 95%. Manipulation of 100% of the amino acids in a domain by use of restriction sites in introns is most common. A number of antibody functions have been localized to a domain or domains as illustrated in Table 1. See Paul, Fundamental Immunology, Raven Press, New York, NY, 1984.

Table 1

Domain(s)	Function
$V_H + V_L$	Antigen binding. Noncovalent assembly of H and L chains.
$C_H^1 + C_L$	Noncovalent assembly of H and L chains. "Spacers" between antigen-binding and effector functions. Covalent assembly of H and L chains.
$C_H^2$	Binding Clq (complement). Control of catabolic rate.
$C_H^3$	Interaction with Fc-receptor on macrophages and monocytes. Noncovalent assembly of H chains.

Table 1 (Cont'd)

Domain(s)	Function
$C_{H2} + C_{H3}$	Interaction with protein A from <u>Staphylococcus aureus</u> . Interaction with Fc-receptor on: (a) placental syncytiotrophoblast (b) neutrophils (c) cytotoxic K-cells (d) intestinal epithelial cells (neonates of certain species)

10

Since the function of these domains is known, a particular effector function can be modified by deleting or inserting a domain related to that function or by substituting a domain of a different class or isotype antibody for a corresponding domain which functions less effectively for a desired property.

15

One or more deletion can occur in preparing a domain-modified constant region of the invention. Multiple deleted domains may be adjacent or non-adjacent. The deleted domain(s) can be the carboxy-terminal domain of the constant region, one or more internal domains, or the amino-terminal domain. Domains related to functions not necessary for or detrimental to a particular use can be eliminated. For example, the  $C_{H2}$  domain can be deleted when complement binding is undesirable. Deletion of non-essential domains may facilitate secretion or assembly of antibody molecules. For example, deletion of  $C_{H1}$ , the proposed binding site of heavy chain binding protein, would permit secretion of heavy chains without associated light chains. Domain deletions can be selected to influence any of the biologic properties of immunoglobulin.

25

30

When the constant region of a heavy chain is modified by a substitution, the substitution involves substantially all of the amino acids of at least one of the domains of  $C_L$ ,  $C_{H1}$ , hinge,  $C_{H2}$  or  $C_{H3}$ , or in the

35

case of IgM and IgE, the C<sub>H</sub>4 domain. The domain can be substituted for with a constant region domain from an antibody of another isotype or class. Additionally, the light chain constant domain can be substituted for heavy region domains, including joining the heavy chain variable region (V<sub>H</sub>) to the light chain constant region (C<sub>L</sub>). Usually, but not necessarily, a domain will be substituted for by the corresponding domain of an antibody of another isotype or class. That is, for example, a C<sub>H</sub>1 domain will usually be exchanged for another C<sub>H</sub>1 domain.

In addition to exchanging domains in order to produce antibodies having currently predictable properties, molecules with unique combinations of biological functions not now known can be prepared as greater insight is gained into the contribution of each domain to biologic activity. For example, it should be possible to combine the ability of IgG<sub>3</sub> to bind Fc receptors on mononuclear cells with the longer serum half-life of IgG<sub>2</sub> if these properties are associated with different domains. The reduced ability of IgG<sub>4</sub> to activate complement may be combined with the ability of IgG<sub>1</sub> to bind with high affinity to Fc receptors. By combining domains from IgA and IgG, it may be possible to produce IgG molecules that can interact with a secretory piece and so be less susceptible to proteolysis in the gut.

The constant region can also be domain-modified by the insertion of substantially all of the amino acids of at least one of the domains of the constant region, C<sub>L</sub>, C<sub>H</sub>1, C<sub>H</sub>2, C<sub>H</sub>3 or C<sub>H</sub>4. In some cases the insertion provides a duplicate of at least one constant region domain already present to provide a constant region having one or more of the domains present as multiple copies. Additionally, the inserted domain can be from an antibody of a different isotype or class or from another chain. Usually the insertion will maintain the domains in their natural order. That is, for

example, all hinge domains present will be between the  $C_{H1}$  and  $C_{H2}$  domain regions. Alternatively, when two or more adjacent domains are inserted, the natural order may be maintained within the inserted group. That is, a second copy of the  $C_{H1}$  and hinge domains may follow the first hinge domain. Domain duplication can also be used to enhance desired functions. For example, carbohydrate is contained in the  $C_{H2}$  domain of IgG; carbohydrate has been used for attaching radioactive labels to Ig. By duplicating  $C_{H2}$ , more carbohydrate will be present and potentially available for use in labeling techniques.

The substituted or inserted domain can be from the same host animal source as the constant region or from a different source. The different source may be from the same or a different species. The substituted or inserted domain can also be a naturally occurring or a genetically modified domain. Genetic modifications contemplated include the addition of amino acids facilitating covalent linking of drugs or radioisotopes, such as by including cysteines or lysines in the domain, usually as a substitution for an amino acid present in the domain as obtained from natural sources. Another anticipated genetic modification would be addition or deletion of carbohydrate, which could be accomplished by substitution of amino acids to provide additional amino acids or delete amino acids that serve as points of attachment for carbohydrates.

A number of exemplary domain-modified constant region antibodies which have been produced are listed in Table 2 in the experimental section. In addition to those listed, a series of  $\gamma_3$  proteins with 0, 1, 2, 3, 4, and 7 hinge exons have been produced. Proteins in which  $V_H$  has been joined to  $C_L$  and  $C_L$  to  $V_H$  have also been produced. These proteins bound antigen and were secreted.

Antibodies of the invention are generally produced in microorganisms or cell lines using an expression vector system comprising transcriptional and translational regulatory sequences and a gene capable of producing a domain-modified constant region under the control of the regulatory sequences. Suitable expression systems are well known and do not constitute a part of this invention. Vectors used for transfection of Ig genes are described in Bio Techniques 4:214-221. These vectors provide one feasible delivery system; delivery by alternative vectors would also be within the scope of the present invention.

The general expression vector systems employed to produce the antibodies of the present invention can be varied in order to provide a number of convenient properties. First, the H and L chains can be on separate plasmids. Although both genes may be on the same plasmid and there is no inherent size limitation, it is more convenient to genetically manipulate smaller plasmids due to the number of novel restriction sites available. Second, unique sites can be introduced within the vectors using linkers to facilitate transferring variable regions between plasmids. This is more easily accomplished in smaller plasmids. Third, once a variable region has been cloned into one expression vector, it is simpler to express it associated with different constant regions in a small plasmid than to require two changes in the same large plasmid prior to expression.

The gene segments encoding the individual antibody domains are typically joined by linking groups. These linking groups can be natural introns or can be introns that have been modified by artificial manipulation. The intron/exon nature of the antibody gene can be used to facilitate preparation of domain-modified constant regions of the invention. The domain structure of antibody molecules is reflected in the struc-

ture of the genes which encode it, with each domain being encoded by a separate exon. The intervening DNA sequences (introns) separating each domain provided ideal sites for manipulating the antibody gene. Since  
5 the intervening sequences are removed by RNA splicing and are not found in the mature mRNA, alterations within the intervening sequence do not affect the structure of the mature protein molecule.

In addition, the RNA splice junctions between  
10 variable and constant region exons in both heavy and light chain genes can be used to advantage in the present invention since these junctions are conserved, even between species. The amino acid at the domain boundary is always formed by two nucleotides from the 5' domain and one nucleotide from the 3' domain. Thus by ligat-  
15 ing gene segments within the intervening DNA sequences, it is possible to make chimeric molecules within and between chains as well as across species.

The general strategy typically used for making  
20 chimeric molecules of the invention is to create cloning cassettes (see Figure 1) containing at least the domains to be manipulated. A similar technique has been used in the prior art for preparing chimeric mouse variable/human constant region heavy chains. When the  
25 vectors for creating chimeric mouse variable/human constant region heavy chains are constructed, for example, a SalI site can be introduced into the intervening sequence using DNA oligonucleotide linkers. This renders the human constant region gene segments into SalI-BamHI  
30 fragments and facilitates the insertion of different constant regions next to the variable region gene segments. Once a variable region prepared in this fashion is cloned, the variable region can be placed next to different constant regions in new cassettes.

35 It has now been determined that a similar approach can be used to create domain cassettes for use in preparing domain-modified antibody chains (see Fig-

ure 2). Using oligonucleotide linkers, unique restriction sites can be introduced into one or more of the intervening sequences separating the exons that encode the domains of the constant-region IgG heavy-chain genes. Examples of restriction sites are set forth in the Figures. Once these linkers are in place, it is possible to exchange, insert, or delete exons and hence immunoglobulin domains (see Figure 3). The new vectors produced by exchange, insertion, or deletion can then be used to produce immunoglobulin molecules having altered structures which enhance the desired functional property.

Specific techniques are described in the examples that follow. Furthermore, now that the present invention has demonstrated that restriction sites can be introduced into the intervening sequences separating the exons that encode the domains, as well as between constant and variable regions, the techniques described in various scientific publications relating to the production of chimeric antibody molecules with antigen-binding domains and constant region domains from different mammalian sources can be applied to the exchange, insertions, and deletion of domains within the constant region using the guidance provided in this specification. A number of relevant publications are set forth above in the section entitled Relevant Literature.

The above strategy is also effective for producing internal deletions within the Ig molecule. Slightly different approaches can be used to create deletions at either the amino or carboxy terminus of the molecule.

There are two ways to make a carboxy terminal deletion. The first is to insert a non-sense codon by site-directed mutagenesis. Using this approach chains terminating at any residue can be created. As an alternative approach, a cassette can be produced and placed 3' of an exon to cause termination after that

exon. As starting material, the gene encoding, for example, C<sub>H</sub>2b-C<sub>H</sub>3 of mouse  $\gamma$ <sub>2b</sub> can be used. This gene contains convenient restriction sites. First, most of C<sub>H</sub>3 is deleted. Then a termination codon in all three reading frames is inserted at the 5' end of the C<sub>H</sub>2 domain. A unique linker can be inserted into the IVS 5' of C<sub>H</sub>2. This cassette can then be placed 3' of any exon. The preceding exon can be spliced to C<sub>H</sub>2 of  $\gamma$ <sub>2b</sub>; the resulting message contains a termination codon at this point.

Several approaches to making amino terminal deletions are possible, and two such approaches are illustrated in Figure 5. In Figure 5A the 5' region of the Ig gene with its promoter and leader are joined to the exons to be expressed. The leader is spliced in reading frame to the exon 3' of it, producing a mRNA with appropriate start sites and encoding a protein. The leader sequence may or may not be cleaved from the completed protein. In Figure 5B the promoter regions and other regions necessary for Ig transcription (indicated by cross-hatched box) are joined directly to the exon. If a translation start site (AUG) is not available, it can be provided by in vitro mutagenesis. The position of the translation start site will determine the size and structure of the protein product.

The invention also contemplates DNA constructs for producing a domain-modified constant region. The constructs comprise DNA sequences encoding polypeptide segments substantially the same as each of the constant region domains joined through a linking group in reading frame at its 5' end to the 3' end of the sequence encoding the previous domain. The constructs will usually additionally include a sequence encoding the variable region, joined through a linking group at its 3' end to the 5' end of the sequence encoding the first constant region domain. When the construct encodes the heavy chain it will include sequences encoding the C<sub>H</sub>1,



hinge, C<sub>H</sub>2, C<sub>H</sub>3 and optionally the C<sub>H</sub>4 domains. Similarly, the construct will contain sequences encoding the C<sub>L</sub> domain when the construct encodes the light chain. The constructs can be synthesized in segments  
5 that are spliced together and cloned, or by any other technique of biotechnology.

When the domain modification is a substitution, the linking group preceding and following the gene segment(s) encoding the domain(s) to be exchanged will  
10 usually comprise a unique restriction site. The same restriction site then will be present in the linking groups surrounding the sequence encoding the domain(s) of another antibody which is to be exchanged. To facilitate duplications or internal deletions, the same  
15 first unique restriction site is present in the linking group which precedes the sequence encoding the domain which is at the amino terminal end of the sequence encoding the domain to be duplicated or deleted. A second unique restriction is present in the linking group  
20 preceding the sequence encoding the domain(s) to be duplicated/deleted in the gene encoding one chain and in the linking group following the sequence encoding the domain(s) in the gene encoding a second identical chain. In this way, following exchange, the domain(s)  
25 is present in two copies (duplicated) in the gene encoding one chain and absent (deleted) in the gene encoding the second chain. When the domain modification is a carboxy-terminal deletion, the linking group following the domain which will comprise the C-terminus  
30 will contain either a non-sense codon or a termination codon.

Cells producing antibodies of the present invention are also provided. The cells contain DNA constructs for expression of a domain-modified constant  
35 region antibody heavy chain described previously. The cells also contain a DNA sequence encoding a light chain region, usually in a separate DNA construct. The

production of cells producing chimeric antibodies (e.g., transfectomas) is well known and described in detail in articles cited in Relevant Literature.

In addition to complete antibodies, antibody  
5 fragments containing domain-modified constant regions also are a part of the present invention. For example, half antibodies prepared from single light and single heavy chains that have assembled to form a specific binding site can be used as monovalent binding proteins.  
10 In addition, non-assembled domain-modified constant regions can be used as antigens for generating specific polyclonal or monoclonal antibodies. Production of particular antibody specificity can be eliminated or enhanced by deletions or insertions, respectively. Use  
15 of a domain-modified antibody having exchanged domains can produce polyclonal antibodies having a unique mixture of specificities in high yield.

The term "antibody" as used in this application, refers to both whole antibodies and fragments  
20 thereof. Whole antibodies contain two light and two heavy chains assembled into the natural Y-shape configuration. Antibody fragments include half antibodies formed from single light and heavy chains that have assembled to produce a specific binding site as well as  
25 fragments of either whole or half antibodies prepared by cleavage with enzymes, such as papain.

The following examples are offered by way of illustration and not by way of limitation.

30

## EXPERIMENTAL

### Example 1

Human  $\gamma_3$  antibody has an extended hinge region consisting of four exons. Human  $\gamma_4$  exhibits quite different properties in spite of extensive sequence similarities (>90% identical residues in C<sub>H</sub>2 and C<sub>H</sub>3) in  
35 their constant regions. IgG<sub>3</sub> genes have been constructed and expressed. The proteins isolated have one, two,

three, or four (wild-type) hinge exons. A change in molecular weight of the heavy chains with the subsequent hinge deletions was noted. In addition, the  $\gamma_3$  hinge has been placed in the  $\gamma_4$  constant region and vice versa. Exchanging the hinge region from IgG<sub>3</sub> and IgG<sub>4</sub> did not alter the ability of these molecules to fix complement and to bind to the Fc receptor.

#### Example 2

10 In order to maximize the usefulness of genetically engineered antibodies for such applications as drug delivery, it is useful to make alterations in the antibody. The limitations are that the antibodies must be assembled and secreted and must retain their ability  
15 to specifically bind antigen.

To determine if there is an upper limit on the size of an antibody molecule which could be produced, an IgG<sub>3</sub> heavy chain in which C<sub>H</sub>1 and the hinge region were duplicated was constructed. In a second construct,  
20 C<sub>H</sub>1, hinge and C<sub>H</sub>2 were duplicated. When the gene with C<sub>H</sub>1 and the hinge duplicated was used for transfection a greatly reduced transfection frequency was seen. When the surviving transfectants were analyzed, none produced any detectable heavy chain protein. These results suggest  
25 that the heavy chain encoded by this construct was toxic to the cells.

In contrast, the gene encoding a heavy chain in which C<sub>H</sub>1, hinge, and C<sub>H</sub>2 were duplicated was expressed following transfection. The chain assembled  
30 with a mouse  $\lambda$  light chain and was secreted. These studies suggest that while there will be limitations as to specific Ig molecules which can be produced, these limitations are not inherently size related.

Example 3

In a related series of studies, deletions of various domains that affect the ability of Ig molecules to assemble, to be secreted, and to function were made.

5 IgG<sub>3</sub> heavy chain genes encoding proteins with deletions of  
C<sub>H</sub>2;  
hinge + C<sub>H</sub>2;  
C<sub>H</sub>1 + hinge; and  
C<sub>H</sub>1 + hinge + C<sub>H</sub>2

10 were constructed and transfected into myeloma cells.

Chimeric heavy chains in which a domain(s) has been deleted were synthesized. J558L was transfected with the chimeric heavy chain gene and transfectants synthesizing protein were isolated. Transfectants were  
15 labeled for 3 hours using <sup>35</sup>S-methionine. Cytoplasmic and secreted Ig were prepared by immunoprecipitating with anti-heavy chain. The immunoprecipitates were analyzed by SDS-PAGE.

When the gene with the deletion of C<sub>H</sub>2 was  
20 used, it was found to direct the synthesis of a protein of the expected molecular weight. This shortened heavy chain assembled with either mouse λ light chain or chimeric V-DNS-human κ light chain into an H<sub>2</sub>L<sub>2</sub> molecule which was secreted.

25 When the hinge + C<sub>H</sub>2 were deleted, the heavy chain apparently assembled into HL half molecules which were secreted. However, it is impossible to say conclusively that these are not H<sub>2</sub>.

When C<sub>H</sub>1 + the hinge were deleted, no assembly  
30 of the heavy chain with either other heavy chains or with L chain occurred. This is not surprising since the free cysteine which forms the interchain disulfide bonds is present in C<sub>H</sub>1. However, even in the absence of interchain disulfide bonds, the shortened heavy  
35 chain is secreted.

A heavy chain in which the variable region is directly joined to C<sub>H</sub>3 was also produced. This heavy chain was secreted when cotransfected with a chimeric light chain into a non-producing myeloma. It did not form covalent bonds with either light chain or another heavy chain.

#### Example 4

Table 2 illustrates a number of domain-modified constant region antibodies which have been produced.

Table 2  
Domain Exchange Proteins Which Have Been Produced

Vector Number	C <sub>H</sub> 1	Hinge	C <sub>H</sub> 2	C <sub>H</sub> 3
1658	Y2	Y3	Y3	Y3
1647	Y3	Y2	Y2	Y2
1654	Y3	Y3	Y2	Y2
1656	Y2	Y2	Y2	Y3
1657	Y3	Y3	Y3	Y2
1673	Y1	Y1	Y4	Y4
1672	Y4	Y1	Y1	Y1
1227	Y3	Y4	Y4	Y4
1228	Y4	Y3	Y3	Y3

Production of proteins prepared from the vectors set forth in Table 2 and analysis of their functions has begun. For example, vector 1654 produces a protein that has been analyzed for its Fc receptor binding activity and, like IgG<sub>2</sub>, does not bind to the Fc receptor of human monocyte cell lines.

All publications and patent applications mentioned in this specification are indicative of the level of skill of those skilled in the art to which this invention pertains. All publications and patent applications are herein incorporated by reference to the same extent as if each individual publication or patent application was specifically and individually indicated to be incorporated by reference.

The invention now being fully described, it will be apparent to one of ordinary skill in the art that many changes and modifications can be made thereto without departing from the spirit or scope of the appended claims.

15

20

25

30

35

WHAT IS CLAIMED IS:

1. An antibody chain having at least one binding site region and a domain-modified constant region.

5

2. An antibody chain of Claim 1, wherein said binding site region and said domain-modified constant region are from the same mammalian source.

10

3. An antibody chain of Claim 1, wherein said binding site region is from a first mammalian source and said domain-modified constant region is from a second mammalian source.

15

4. An antibody chain of Claim 3, wherein said first mammalian source is of the same species as said second mammalian source.

20

5. An antibody chain of Claim 3, wherein said first mammalian source is of a different species from said second mammalian source.

25

6. An antibody chain of Claim 1, wherein said domain-modified constant region contains a deletion of substantially all of the amino acids of at least one of the domains of  $C_{H1}$ , hinge,  $C_{H2}$ ,  $C_{H3}$ , or  $C_{H4}$  and the remaining amino acids of said domain-modified constant region have substantially the same amino acid sequence as that of at least one domain of a constant region of a mammalian antibody.

30

7. An antibody chain of Claim 6, wherein said deletion comprises substantially all of the amino acids of at least two domains.

35

8. An antibody chain of Claim 7, wherein said domains are non-adjacent.

5 9. An antibody chain of Claim 1, wherein said domain-modified constant region has substantially the same amino acid sequence as that of a constant region of a mammalian antibody with the proviso that substantially all of the amino acids of at least one of the domains C<sub>L</sub>, C<sub>H</sub>1, hinge, C<sub>H</sub>2, C<sub>H</sub>3, or C<sub>H</sub>4 are substituted by substantially all of the amino acids of at least one of said domains from a different mammalian antibody chain.

15 10. An antibody chain of Claim 9, wherein said domain-modified constant region is a substitution of a corresponding domain of an antibody of another isotype, or class.

20 11. An antibody chain of Claim 9, wherein said substituted domain is from the same host animal source as said constant region.

25 12. An antibody chain of Claim 9, wherein the source of said substituted domain is from a different species than the source of said constant region.

30 13. An antibody chain of Claim 1, wherein said domain-modified constant region has the same amino acid sequence as that of a constant region of a mammalian antibody and further comprises an insertion of substantially all of the amino acids of at least one of the domains of C<sub>L</sub>, C<sub>H</sub>1, hinge, C<sub>H</sub>2, C<sub>H</sub>3 and C<sub>H</sub>4.

35 14. An antibody chain of Claim 13, wherein said insertion is of at least two domains.



15. The antibody chain of Claim 13, wherein said insertion is the duplication of at least one domain of said constant region.

5 16. A DNA construct, comprising a DNA sequence encoding an antibody of Claim 1.

10 17. A DNA construct for producing a domain-modified constant region of an antibody heavy chain comprising:

(a) a first DNA sequence coding for a polypeptide substantially the same as the  $C_{H1}$  region of an antibody heavy chain;

15 (b) a second DNA sequence joined through a linking group in reading frame at its 5' end to the 3' end of said first DNA sequence, said second sequence coding for a polypeptide substantially the same as the hinge region of an antibody heavy chain;

20 (c) a third DNA sequence joined through a linking group in reading frame at its 5' end to the 3' end of said second DNA sequence, said third sequence coding for a polypeptide substantially the same as the  $C_{H2}$  region of an antibody heavy chain; and

25 (d) a fourth DNA sequence joined through a linking group in reading frame at its 5' end to the 3' end of said third DNA sequence, said fourth sequence coding for a polypeptide substantially the same as the  $C_{H3}$  region of an antibody heavy chain;

30 wherein at least one of said linking groups contains a restriction site unique to said construct.

18. The DNA construct of Claim 17, wherein two of said linking groups comprise unique restriction sites.

35 19. The DNA construct of Claim 17, additionally comprising a fifth DNA sequence joined through a linking group at its 5' end to the 3' end of said

fourth sequence coding for a polypeptide substantially the same as the C<sub>H</sub>4 region of an antibody heavy chain.

20. The DNA construct of Claim 17, wherein said  
5 linking group joining the sequence encoding the C-terminal domain of the antibody heavy chain to the preceding sequence comprises a termination codon or a non-sense codon.

10 21. A DNA construct for expression of a domain-modified constant region antibody heavy chain comprising:

(a) a first DNA sequence coding for a polypeptide substantially the same as the variable region  
15 of an antibody heavy chain;

(b) a second DNA sequence joined through a linking group in reading frame at its 5' end to the 3' end of said first DNA sequence, said second sequence coding for a polypeptide substantially the same as the  
20 C<sub>H</sub>1, region of an antibody heavy chain;

(c) a third DNA sequence joined through a linking group in reading frame at its 5' end to the 3' end of said first DNA sequence, said third sequence coding for a polypeptide substantially the same as the  
25 hinge region of an antibody heavy chain;

(d) a fourth DNA sequence joined through a linking group in reading frame at its 5' end to the 3' end of said third DNA sequence, said fourth sequence coding for a polypeptide substantially the same as the  
30 C<sub>H</sub>2 region of an antibody heavy chain; and

(e) a fifth DNA sequence joined through a linking group in reading frame at its 5' end to the 3' end of said fourth DNA sequence, said fifth sequence coding for a polypeptide substantially the same as the  
35 C<sub>H</sub>3 region of an antibody heavy chain;

wherein said construct encodes a domain-modified antibody chain.

22. A DNA construct for expression of a domain-modified constant region antibody light chain comprising:

5 (a) a first DNA sequence coding for a polypeptide substantially the same as the variable region of an antibody light chain; and

10 (b) a second DNA sequence joined through a linking group in reading frame at its 5' end to the 3' end of said first DNA sequence, said second sequence coding for a polypeptide substantially the same as the C<sub>H</sub>1 region of an antibody heavy chain.

23. A cell which contains a DNA construct of Claim 15 21 for expression of a domain-modified constant region antibody heavy chain.

24. A cell according to Claim 23 additionally comprising a DNA sequence encoding an antibody light 20 chain.

25. A method for producing a domain-modified constant region antibody which comprises:

25 (a) growing cells according to Claim 24 in a nutrient medium, whereby said DNA constructs are expressed and said heavy and light chains are intracellularly bound together to form an antibody; and

(b) isolating said antibody.

30

35

1/2

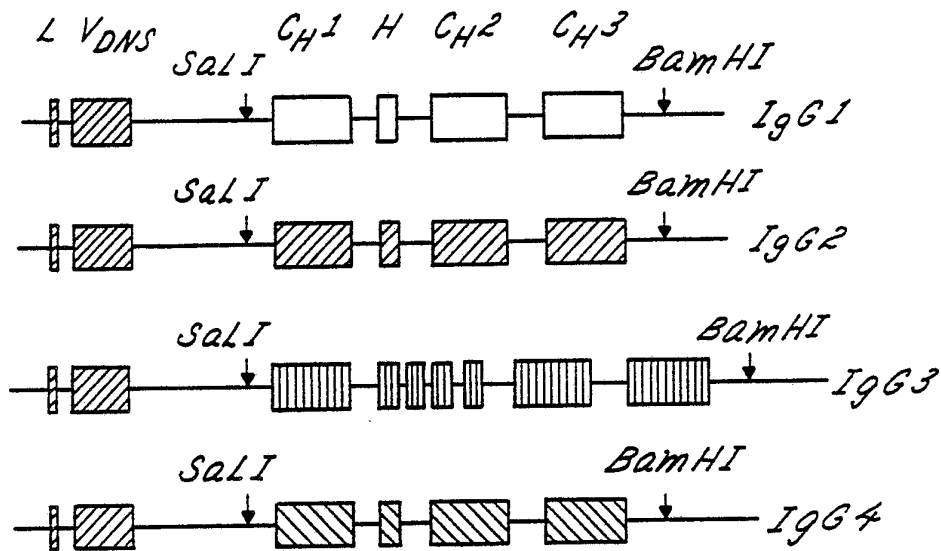

FIG. 1

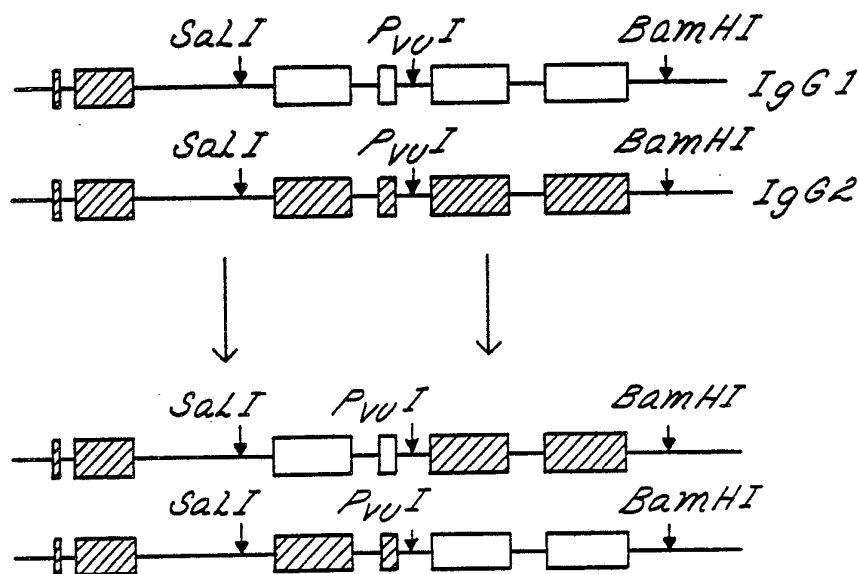

FIG. 2

2/2

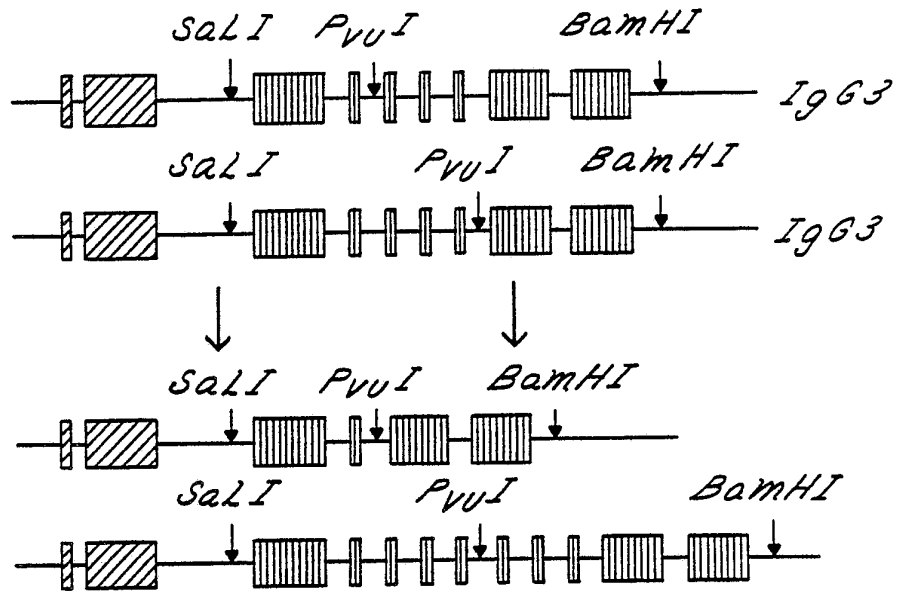

FIG. 3

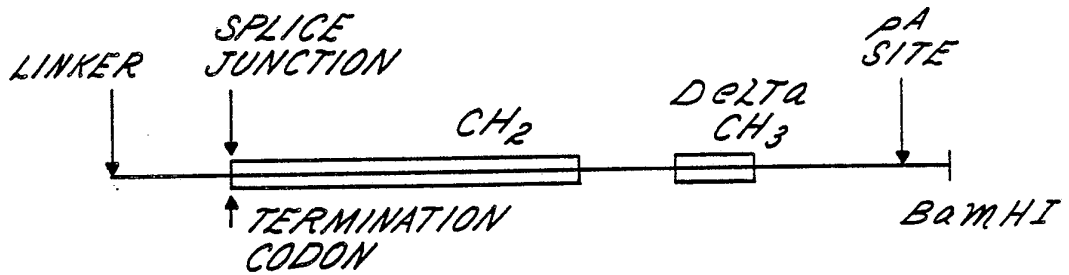

FIG. 4

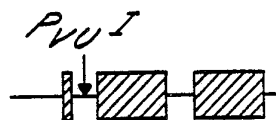

FIG. 5A

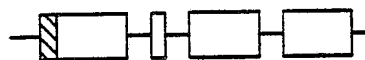
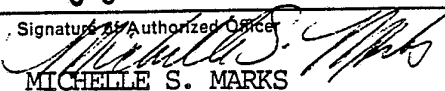

FIG. 5B

# INTERNATIONAL SEARCH REPORT

International Application No. PCT/US89/00297

<b>I. CLASSIFICATION OF SUBJECT MATTER</b> (if several classification symbols apply, indicate all) <sup>6</sup>		
According to International Patent Classification (IPC) or to both National Classification and IPC IPC(4): C12N 15/00; C12P 21/00; C07K 15/00 U.S. CL.: 435/172.3; 435/68; 530/387		
<b>II. FIELDS SEARCHED</b>		
Minimum Documentation Searched <sup>7</sup>		
Classification System	Classification Symbols	
U.S.	530/387, 388; 536/27; 435/68,70, 435/172.3, 255, 320, 240.1	
Documentation Searched other than Minimum Documentation to the Extent that such Documents are Included in the Fields Searched <sup>8</sup>		
Chemical Abstracts database and APS database; keywords: domain modified, chim(a)eric immunoglobulin or antibody, domain modified antibody chain.		
<b>III. DOCUMENTS CONSIDERED TO BE RELEVANT</b> <sup>9</sup>		
Category *	Citation of Document, <sup>11</sup> with indication, where appropriate, of the relevant passages <sup>12</sup>	Relevant to Claim No. <sup>13</sup>
<u>X</u> , <u>E</u> <u>Y</u> , <u>E</u>	US, A, 4,816,567 (CABILLY) 28 March 1989, particularly columns 27-28.	3,5,9,10, 12-15,17, 19-21,23, 24,25 <hr/> 1-2,4, 6-8,11, 16,18,22
<u>X</u> <u>Y</u>	EP 125023 (CABILLY) 14 November 1984 See pages 1-58 particularly page 13.	3,5,9,10, 12-15,17, 19-21,23, 24,25 <hr/> 1-2,4, 6-8,11, 16,18,22
<u>X</u> <u>Y</u>	EP 171496 (TANIGUCHI) 19 February 1986	3,5,9,10, 12-15,17, 19-21,23, 24,25 <hr/> 1-2,4, 6-8,11, 16,18,22
<p>* Special categories of cited documents: <sup>10</sup></p> <p>"A" document defining the general state of the art which is not considered to be of particular relevance</p> <p>"E" earlier document but published on or after the international filing date</p> <p>"L" document which may throw doubts on priority claim(s) or which is cited to establish the publication date of another citation or other special reason (as specified)</p> <p>"O" document referring to an oral disclosure, use, exhibition or other means</p> <p>"P" document published prior to the international filing date but later than the priority date claimed</p> <p>"T" later document published after the international filing date or priority date and not in conflict with the application but cited to understand the principle or theory underlying the invention</p> <p>"X" document of particular relevance; the claimed invention cannot be considered novel or cannot be considered to involve an inventive step</p> <p>"Y" document of particular relevance; the claimed invention cannot be considered to involve an inventive step when the document is combined with one or more other such documents, such combination being obvious to a person skilled in the art.</p> <p>"&amp;" document member of the same patent family</p>		
<b>IV. CERTIFICATION</b>		
Date of the Actual Completion of the International Search	Date of Mailing of this International Search Report	
19 April 1989	09 JUN 1989	
International Searching Authority	Signature of Authorized Officer	
ISA/US	 MICHELLE S. MARKS	

**FURTHER INFORMATION CONTINUED FROM THE SECOND SHEET**

--	--	--

**V.  OBSERVATIONS WHERE CERTAIN CLAIMS WERE FOUND UNSEARCHABLE <sup>1</sup>**

This international search report has not been established in respect of certain claims under Article 17(2) (a) for the following reasons:

1.  Claim numbers \_\_\_\_\_, because they relate to subject matter <sup>12</sup> not required to be searched by this Authority, namely:

2.  Claim numbers \_\_\_\_\_, because they relate to parts of the international application that do not comply with the prescribed requirements to such an extent that no meaningful international search can be carried out <sup>13</sup>, specifically:

3.  Claim numbers \_\_\_\_\_, because they are dependent claims not drafted in accordance with the second and third sentences of PCT Rule 6.4(a).

**VI.  OBSERVATIONS WHERE UNITY OF INVENTION IS LACKING <sup>2</sup>**

This International Searching Authority found multiple inventions in this international application as follows:

- I. Claims 1-15, drawn to antibody chains.
- II. Claims 16-25 drawn to DNA constructs, cells and an method for producing an antibody.

1.  As all required additional search fees were timely paid by the applicant, this international search report covers all searchable claims of the international application. Telephone practice.

2.  As only some of the required additional search fees were timely paid by the applicant, this international search report covers only those claims of the international application for which fees were paid, specifically claims:

3.  No required additional search fees were timely paid by the applicant. Consequently, this international search report is restricted to the invention first mentioned in the claims; it is covered by claim numbers:

4.  As all searchable claims could be searched without effort justifying an additional fee, the International Searching Authority did not invite payment of any additional fee.

**Remark on Protest**

- The additional search fees were accompanied by applicant's protest.
- No protest accompanied the payment of additional search fees.

## III. DOCUMENTS CONSIDERED TO BE RELEVANT (CONTINUED FROM THE SECOND SHEET)

Category *	Citation of Document, with indication, where appropriate, of the relevant passages	Relevant to Claim No
$\frac{X}{Y}$	<p><u>Nature</u>, Volume 314 Issued 21 March 1985 M.S. Neuberger, "A haptan specific chimeric IgE antibody with human physiological effector function". See pages 268-270.</p>	<p>1-5,9-17 <u>19,21,23</u> 6-8,18, 20,22, 24-25</p>
$\frac{X}{Y}$	<p><u>BioTechniques</u> Volume 4 Issued March 1986 V.T. Oi, "Chimeric Antibodies", See pages 214-220.</p>	<p>1-5,9-17, <u>19,21-25</u> 6-8, 18,20</p>
$\frac{X}{Y}$	<p><u>Immunology Today</u> Volume 7 Issued December 1986, H.L. Aguila "The production of more useful monoclonal antibodies", See pages 380-383.</p>	<p>1-5,9-17 <u>19,21-25</u> 6-8, 18,20</p>
$\frac{X}{Y}$	<p><u>Nature</u>, Volume 312, Issued 13 December 1984 G.L. Boulianne "Production of Functional mouse/human antibody" See pages 643-646.</p>	<p>1-5,9-17 <u>19,21-25</u> <u>6-8,18</u> 20</p>
$\frac{X}{Y}$	<p><u>Science</u>, Volume 229, Issued 20 September 1985 S.L. Morrison "Transfections Provide Novel Chimeric Antibodies". See pages 1202-1207 particularly pages 1205 and 1207.</p>	<p>1-5,9-15 16-17,19 <u>21-25</u> <u>18,20</u> 6-8</p>
$\frac{X}{Y}$	<p><u>Proceedings of the National Academy of Sciences, USA</u>, Volume 81, Issued November 1984 S.L. Morrison, "Chimeric human antibody molecules: mouse antigen-binding domains with human constant region domains." See pages 6851-6855.</p>	<p>1-5,9-17, <u>19,21-25</u> <u>18,20</u> 6-8</p>



Attachment to PCT Telephone Memorandum

Detailed Reasons for Holding Lack of Unity of Invention

The antibody chain of Group I could be produced by a method different than that of Group II, such as chemical synthesis.