



(72) ATTENBERG, Samuel S., US

(71) APBI INTERACTIVE KIOSK SYSTEMS, US

(51) Int.Cl.⁶ G06F 3/12, G03B 29/00, G06K 15/00

(30) 1996/01/22 (08/589,124) US

(54) **KIOSQUE PHOTOGRAPHIQUE INTERACTIF A VISION
DIRECTE ET PROCEDE D'IMAGERIE ASSOCIE**

(54) **DIRECT VIEW INTERACTIVE PHOTO KIOSK AND IMAGE
FORMING PROCESS FOR SAME**

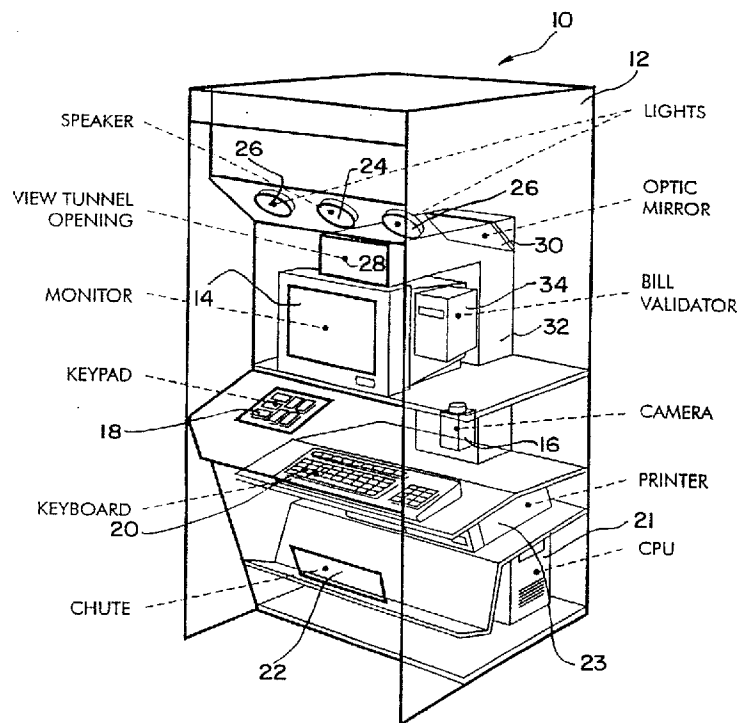

(57) Cette invention concerne un kiosque photographique interactif qui, selon une de ses réalisations, présente une face ouverte droite permettant à un utilisateur de se tenir debout, directement face au kiosque. Ce kiosque défocalise optiquement l'image d'arrière-plan et y substitue une image de synthèse sélectionnée, et il permet à l'utilisateur d'arrêter et de figer une image sélectionnée affichée sur un écran de visualisation (S20, S21). Les utilisateurs peuvent choisir parmi une sélection de diverses images de premier plan produites par ordinateur. Selon une réalisation préférée, l'image sélectionnée et figée est une image numérique qui subit

(57) An interactive photo kiosk in which, in one embodiment thereof, presents an upright open face which enables a user to stand directly in front of the kiosk, which optically defocuses the background image and substitutes a selected computer generated image, and which enables the user to pose and freeze a selected image made visible to the user on a display screen (S20, S21). Users may choose from among a menu of different computer generated foreground images. In a preferred embodiment, the selected frozen image is in digital form and is processed electronically to form a single digital multiple image of the same image in a selected area

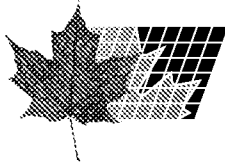

(21) (A1) **2,215,937**
(86) 1997/01/22
(87) 1997/07/31

un traitement électronique de façon à produire une image numérique unique comportant de multiples vues de la même image suivant un format surfacique sélectionné, ladite image unique produisant, lorsqu'elle est transmise à un dispositif d'impression (S22, S23) de recopie d'écran, une image multiple de la même image figée sur un seul feuillet, chacune des multiples images du feuillet pouvant être détachée séparément et utilisée indépendamment des autres (S24, S25).

format which when delivered to a printing apparatus (S22, S23) for hard copy print-out, produces a multiple image of the same frozen image on a single sheet wherein each of the multiple images can be peeled off the single sheet and used separately from each other (S24, S25).



PCT

WORLD INTELLECTUAL PROPERTY ORGANIZATION
International Bureau

INTERNATIONAL APPLICATION PUBLISHED UNDER THE PATENT COOPERATION TREATY (PCT)

(51) International Patent Classification ⁶ : G06K 15/00, G03B 29/00, H04N 7/18, 9/47, G03F 3/10	A1	(11) International Publication Number: WO 97/27563 (43) International Publication Date: 31 July 1997 (31.07.97)
<p>(21) International Application Number: PCT/US97/00553</p> <p>(22) International Filing Date: 22 January 1997 (22.01.97)</p> <p>(30) Priority Data: 08/589,124 22 January 1996 (22.01.96) US</p> <p>(60) Parent Application or Grant (63) Related by Continuation US 08/589,124 (CIP) Filed on 22 January 1996 (22.01.96)</p> <p>(71) Applicant (for all designated States except US): APBI INTERACTIVE KIOSK SYSTEMS [US/US]; 801 North Fairfax Street, Alexandria, VA 22314 (US).</p> <p>(72) Inventor; and (75) Inventor/Applicant (for US only): ATTENBERG, Samuel, S. [US/US]; 800 25th Street, N.W., Washington, DC 20037 (US).</p> <p>(74) Agents: DeLUCA, Vincent, M. et al.; Rothwell, Figg, Ernst & Kurz, 555 13th Street, N.W. #701 East, Washington, DC 20004 (US).</p>		<p>(81) Designated States: AL, AM, AT, AU, AZ, BB, BG, BR, BY, CA, CH, CN, CZ, DE, DK, EE, ES, FI, GB, GE, HU, IL, IS, JP, KE, KG, KP, KR, KZ, LK, LR, LS, LT, LU, LV, MD, MG, MK, MN, MW, MX, NO, NZ, PL, PT, RO, RU, SD, SE, SG, SI, SK, TJ, TM, TR, TT, UA, UG, US, UZ, VN, ARIPO patent (KE, LS, MW, SD, SZ, UG), Eurasian patent (AM, AZ, BY, KG, KZ, MD, RU, TJ, TM), European patent (AT, BE, CH, DE, DK, ES, FI, FR, GB, GR, IE, IT, LU, MC, NL, PT, SE), OAPI patent (BF, BJ, CF, CG, CI, CM, GA, GN, ML, MR, NE, SN, TD, TG).</p> <p>Published <i>With international search report.</i></p>
<p>(54) Title: DIRECT VIEW INTERACTIVE PHOTO KIOSK AND IMAGE FORMING PROCESS FOR SAME</p>		
<p>(57) Abstract</p>		
<p>An interactive photo kiosk in which, in one embodiment thereof, presents an upright open face which enables a user to stand directly in front of the kiosk, which optically defocuses the background image and substitutes a selected computer generated image, and which enables the user to pose and freeze a selected image made visible to the user on a display screen (S20, S21). Users may choose from among a menu of different computer generated foreground images. In a preferred embodiment, the selected frozen image is in digital form and is processed electronically to form a single digital multiple image of the same image in a selected area format which when delivered to a printing apparatus (S22, S23) for hard copy print-out, produces a multiple image of the same frozen image on a single sheet wherein each of the multiple images can be peeled off the single sheet and used separately from each other (S24, S25).</p>		<pre> graph TD S20[GENERATE ELECTRONIC SINGLE IMAGE INFORMATION] --> S21[FORMAT MULTIPLE IMAGE FILE CONFIGURATION AFTER OPTIONAL FREEZE IMAGE SELECTION] S21 --> S22[GENERATE ELECTRONIC MULTIPLE IMAGE INFORMATION] S22 --> S23[DELIVER ELECTRONIC MULTIPLE IMAGE INFORMATION TO PRINTER] S23 --> S24[PRINT MULTIPLE IMAGES ON STICKERS ON SINGLE SHEET] S24 --> S25[DELIVER SINGLE SHEET MULTIPLE IMAGE STICKER PRODUCT TO USER] </pre>

DIRECT VIEW INTERACTIVE PHOTO KIOSK
AND IMAGE FORMING PROCESS FOR SAME

CROSS-REFERENCE TO RELATED APPLICATION

5 This application is a continuation-in-part of
prior application Serial No. 589,124, filed January 22,
1996.

BACKGROUND OF THE INVENTION

FIELD OF THE INVENTION

10 The present invention relates to photo kiosks of
the type which are typically located in public access
locations and which provide photographs to persons
desiring the same who interact with the kiosk and to an
image forming process for such kiosks. In the prior
art, such kiosks were typically called "photo booths"
15 and provided an enclosed area in which persons desiring
a photograph of themselves could pose against a
standard foreground while a photograph was taken and
processed and delivered by the mechanisms of the photo
booth. The end product of such prior art photo booths
20 was typically a single image of the subject or separate
multiple prints of the same image.

The present invention relates to an improved
interactive photo kiosk in which a person desiring a
photograph can pose directly in front of the kiosk to
25 have a picture taken against a selected computer
generated foreground and in which a multiple image
format in the form of "stickers" on a single sheet is
delivered to the user from a frozen image selected by
the user.

30 BACKGROUND AND PRIOR ART

Various types of photo kiosks are known in the
prior art. In the early prior art, such photo kiosks
were configured in the form of photo booths in which an

enclosed or partially enclosed area was provided in which the subject or subjects could pose against a standard foreground fixed in the enclosed area while a photograph was taken. After the photograph was taken, the apparatus of the photo booth would process the photograph and deliver a finished print to the subject. Typically, the finished product was in the form of an image or, in some cases, additional separate prints of the same image could be obtained from the apparatus.

Other types of photo booths in the form of photo kiosks were also known in the art as the art evolved from the earlier photo booth structures. These later photo kiosks included various types in which the enclosed or partially enclosed area was eliminated and in which the subject could input a selected foreground image. However, such later photo kiosks have not been user friendly in the sense of providing an effective visually interactive interface with the user to enable consistently acceptable results under the full control of the user and being able to attract users with effective visual displays. In addition, the format of the finished product delivered to the user was in the form of a single image or in the form of additional and separate prints of the same image. This specific format of the finished product of such prior art apparatus has limited the use and appeal of such prior art photo booth apparatus.

SUMMARY OF THE INVENTION

The present invention provides an improved interactive photo kiosk which, in one embodiment thereof, presents an upright open face which enables a user to stand directly in front of the kiosk, which optically defocuses the background image and substitutes a selected computer generated image, which enables the user to pose and freeze a selected image made visible to the user using a power zoom with automated focus prior to the actual taking of a

photograph, and which utilizes a touch screen to operate all functions from a displayed user friendly menu. Users may choose from among a menu of different computer generated foreground images and can pose and size themselves on a viewing screen as they like using the power zoom function. The viewing screen has a countdown timer which indicates the time remaining in which to pose before the image is frozen. If the user does not like the frozen image, the image can be unfrozen and re-posed with a new foreground if desired. Once a selected frozen image is selected, the kiosk apparatus delivers hard copy prints of the image within one to two minutes.

The improved kiosk of the present invention includes, in one embodiment thereof, a camera with internal power operated autofocus, auto iris, and zoom lens. The improved kiosk is also provided with a display screen visible to passersby to demonstrate and advertise the product to potential users. In another embodiment, the improved kiosk utilizes an extended internally folded optical path lengthening the camera to subject distance to enhance defocusing of the background image.

In a preferred embodiment of the present invention, the selected frozen image is in digital form and is processed electronically to form a single digital multiple image of the same image in a selected area format which, when delivered to a printing apparatus for hard copy print-out, produces a multiple image of the same frozen image on a single sheet wherein each of the multiple images can be peeled off the single sheet and used separately from each other. The peel apart images, referred to herein as "stickers", are preferably provided with a slightly adhesive backing so that they will stick and adhere to a surface to which they are applied.

According to another preferred embodiment of the invention, the image of the user may be selectively altered by the user with respect to the selected foreground image, to modify the appearance of the image of the user with respect to the selected foreground image.

Other features of the improved interactive kiosk of the present invention will be apparent from the following detailed description of preferred embodiments taken in connection with the accompanying drawings.

BRIEF DESCRIPTION OF THE DRAWINGS

Fig. 1 is a perspective view of a direct view, interactive photo kiosk, shown with the internal components thereof visible, embodying the present invention;

Fig. 2 is a perspective view of another embodiment of the present invention in the form of a direct view, interactive photo kiosk;

Fig. 3 is a flow chart showing the process and sequence of operation of the embodiments of Figs. 1 and 2;

Fig. 4 is a flow diagram showing in further detail certain the steps of the process of Fig. 3 for printing multiple images;

Fig. 5 is an illustration of the finished product of the preferred embodiment of the apparatus and method of the present invention in the form of a multiple image format with images formed on peel apart stickers;

Fig. 6 is a flow diagram showing the overall process of a preferred embodiment of the present invention;

Fig. 7 is a block diagram showing a first alternate embodiment of the invention in which the user of the system may selectively alter the appearance of the user's image being printed; and

Fig. 8 is a block diagram showing a second alternate embodiment of the invention in which the user

of the system may selectively alter the appearance of the user's image being printed.

DETAILED DESCRIPTION OF THE INVENTION

Referring now to the embodiment shown in Fig. 1, a photo kiosk 10 is formed of an outer cabinet 12 containing a monitor 14, a camera 16, a keypad 18, a keyboard 20, a CPU 21 and a delivery chute 22 for delivering the finished product from a printer 23. The kiosk 10 also contains a speaker 24 for delivering instructions to a user and lights 26 for lighting the subject to be photographed. A folded optical path is provided from a view tunnel opening 28 reflecting from an optical mirror 30 to the camera 16. The folded optical path is enclosed in a casing 32. The camera 16 is an electronic camera which produces a digital image and which is preferably provided with an internal power autofocus, auto iris, and zoom lens.

Passers-by see a scrolling sales attract loop which is displayed on the monitor 14 which demonstrates the process of the apparatus and which displays on the screen the finished product, which is a sheet of peel-off stickers as shown in one form in Fig. 5 and which will be explained later in detail. A subject wishing to use the kiosk 10 stands directly in front of the apparatus and interacts with the keypad 18 and keyboard 20 to operate the apparatus from a menu displayed on the monitor 14 and delivered by stored voice instructions delivered through the speaker 24. One of the functions of the keyboard 20 is to provide the owner/operator of the kiosk access to the software program that controls the processes of the system and to an integral accounting, audit and security encryption file that allows the owner/operator to verify cash receipts by image choice, by day, month and annually, and cumulatively, as well as access to the use of a materials tracking record of users entering the system through its password system, and an out-of-

service record showing the various error files and the time and duration of each error and the time when the error was corrected.

5 The sequence of operation of the system by users of the system is shown in Fig. 3 starting with the scrolling sales loop at step S1.

10 The user is invited to use the apparatus by inserting a currency bill into a bill validator 34, which may also contain a slot 36 for accepting credit/debit cards. Other forms of accepting payment may also be provided. After payment has been made (step S2 in Fig. 3) and accepted, the system alerts the CPU 21 at step S3 and the CPU turns on the live camera mode and displays the image choice options at step S4.

15 The keypad 18 is configured to allow order commands to be entered by the user to the computer interface based on menu choices displayed on the monitor 14.

After the initial activation of the system, the available choices for foreground images to be

20 electronically inserted on the image of the subject are displayed on the monitor 14 in the form of numbered windows, each numbered window representing a choice that may be selected by the user as a foreground for the pose. In the embodiment of Fig. 1, typically about

25 sixteen different image foregrounds are displayed on the screen for selection by the user by designating the number of the window of the desired image foreground.

Instead of providing for selection of the choices by using the keypad 18, the numbered windows may be

30 displayed on the monitor 14 in the form of a touch display which enables the user to select the desired window number by touching one of the windows displayed on the monitor. When the window of choice is selected at step S5 in Fig. 3, either by using the keypad 18 in

35 the non-touch screen version or by touching the selected window on the screen in the case of a touch screen, users see themselves on the full screen with

the selected foreground image. The screen also displays instructions directing the users to size themselves with the power zoom function and to pose themselves as they like. The screen also displays at
5 step S6 a count-down timer indicating the time remaining before a pose is frozen by the recording of a digital image at step S7.

After the image is freeze-captured at step S7, the frozen image is displayed on the monitor 14 for
10 viewing by the user. At this point, the user may be given the option of unfreezing the stored image and of choosing another pose or another foreground image if the user desires to do so. Once the final capture-freeze is activated at step S7, the CPU 21 sends the
15 frozen image to the printer at step S9 for processing as illustrated in Fig. 4 and the printer then prints the captured image for delivery to the user at step S9, after which the system returns to the monitor sales scroll at step S10.

20 Step S9 is illustrated in further detail in Fig. 4 in which steps S11 through S15 show the steps carried out at the printer in accordance with the present invention and represented by step S9 of Fig. 3. At
25 step S11 in Fig. 4, the "freeze" image is received from the CPU 21. In step S12, the electronic digital image received from the CPU is processed into a new electronic digital file containing multiple images of the single frozen image in a format suitable for
30 printing on a single sheet from the sensitized sheets stored in the printer 23.

The printer 23 is preferably a thermal dye sublimation printer which produces an image by thermal
activating of dyes in image receiving sheets stored in the printer. Such thermal dye sublimation printers are
35 well known in the art and the operation thereof will therefore not be further explained here. Other types of printers capable of producing a hard copy print from

a digitally stored image may also be used in the apparatus of the present invention.

After the multiple image file is generated in step S12, the file so generated is delivered to the printer 23 in step S13 and the multiple image file is printed on a single sheet in step S14 and delivered as the finished product in step S15.

The finished product, as shown in Fig. 5., comprises a single multilayered sheet 50 with multiple images 52 of the single frozen image formed thereon by the printer 23. In the embodiment shown in Fig. 5, sixteen identical rectangular images are shown on the single sheet, but any number can be selected and the images may be arranged in any form. That is, the multiple image file generated in step S12 of the process shown in Fig. 4 may be arranged in any format for printing on a single sheet.

The image containing sheet 50 of the embodiment of Fig. 5 is a multilayered sheet in the form of a base sheet 54, which is visible at the point where one of the images is shown partially peeled back from the base sheet 54, and an image bearing sheet 56 (shown as the partially peeled back portion). The image bearing sheet 56 is scored along horizontal lines 58 and vertical lines 60 defining the image areas so that the individual images 52 are removably secured to the base sheet 54 and can be separately peeled off from the base sheet 54 and removed in that manner. The image bearing sheet 56 is lightly adhered to the base sheet 54 so that images so removed retain some adhesive on the back surface thereof and can thus be adhered to surfaces to which they are applied.

The multiple image "stickers" so produced have a variety of uses and may be used in various forms of identification documents and the like, for example. The term "stickers", as used herein, refers to peel apart images on a base sheet, such as the images 52 on

the base sheet 54, and the term "sticker sheet" refers to the overall assembly of the removable stickers and the base sheet as shown in Fig. 5.

5 In the embodiment of the invention as shown in Fig. 1, the folded optical path which extends from the subject through the view tunnel opening 28 and the optic mirror 30 to the camera 16 results in the attainment of a narrow depth of field at the range of the subject with resultant complete defocusing of the background image around the subject. The apparatus is also configured so that the subject can stand directly in front of the kiosk and can view the image directly on the monitor 14 while manipulating the controls of the apparatus. The apparatus therefore takes up very little floor space and at the same time affords flexibility and ease of use to a subject in forming a suitable pose for the desired image composition. The lights 26 can also be more precisely arranged to provide lighting to the region in which the subject will stand while operating the controls and posing for the desired image composition. The advertising message which is scrolled and displayed on the monitor 14 is also highly visible to passers-by from the open face of the kiosk.

25 The overall method of the present invention is shown in the flow diagram of Fig. 6. The method begins with the generation of electronic single image information in step S20. This takes place at the camera 16 which, as described above, is an electronic imaging device which creates an electronic file, usually in the form of digital data, which is representative of the single image projected onto the imaging screen of the camera 16. This step includes the electronic incorporation into the image of the user of a foreground image selected by the user from among the multiple foreground images presented on the display 14. For example, the user may desire to be posed with

the foreground image of a selected historic building or monument or with a floral foreground image. Electronic processing techniques for generating first electronic image information from a projected image and for
5 electronically incorporating a foreground image into the first electronic image information are well known in the art and will not be further described here.

In step S21, a multiple image format is selected for formatting the electronic single image information
10 into a multiple image file configuration in which multiple images identical to the single image are arranged in a selected pattern such as shown in Fig. 5. Step S21 may also preferably include, as a preliminary step before the multiple image file configuration is
15 formatted, the presentation of a "freeze image" to the user on the viewing screen of the display 14 for review by the user and for selection by the user for hard copy print out if the freeze image is deemed acceptable. If the freeze image is not deemed acceptable by the user,
20 the image may be discarded and the process may be recycled from the beginning to create a new freeze image for selection by the user. In step S22, electronic multiple information is generated by electronic processing in the format selected in step
25 S21, whereby electronic multiple image information capable of controlling a printer to print multiple images on a single sheet is produced.

Techniques for electronically formatting and generating the electronic multiple information from the
30 electronic single image information as illustrated in steps S21 and S22, such that a printer will print out multiple images of the same image on a single sheet, are well known to those skilled in the art.

In step 23, the electronic multiple image
35 information is delivered to the printer and, in step S24, the multiple images are printed out on stickers on a single sheet in the format as generally shown in Fig.

5. It is to be understood that the number of images selected for printing out on a single sheet may vary from that shown in Fig. 5 and that the arrangement of the images selected may be in any desired pattern.

5 In step S25, the finished product in the form of a sheet of image stickers, such as shown in Fig. 5, for example, is delivered to the user. The finished product is delivered automatically through the delivery chute 22 in the embodiment shown in Fig. 1. The entire process is carried out while the user waits and, in the embodiment shown in Fig. 1 using the process of the invention as described above, the finished product can be delivered in less than two minutes, typically in about 80 seconds or so.

10 15 Although the presentation of the freeze image to the user is shown in the embodiment of Figs. 4 and 6 at a point preliminary to the generation of the electronic multiple image information in step S12 in Fig. 4 and in step S22 in Fig. 6, the presentation of the freeze image for viewing by the user may be carried out at any point in the process after the selection by the user of the desired foreground image and prior to the actual hard copy print out of the multiple image single sheet final product. However, in the embodiment utilizing the methods as set forth in the flow diagrams of Figs. 4 and 6, the freeze image is not generated until after the user has selected the desired foreground image since the selected foreground image is incorporated in the electronically generated image which is presented to the user for freezing if deemed acceptable.

20 25 30 35 Another embodiment of the invention is shown in Fig. 2. In this embodiment, the components of the kiosk 10 are arranged differently from those shown in the embodiment of Fig. 1. In the embodiment of Fig. 2, the same reference numerals are used to designate elements which are the same as those utilized in the embodiment of Fig. 1.

In this embodiment, the camera 16 is positioned directly over the monitor 14 and the extended optical path of the embodiment of Fig. 1 has been eliminated. The keypad 18 of the embodiment of Fig. 1 has also been
5 eliminated and the functions performed have been installed in a touch screen 15.

In the embodiment of Fig. 2, the user can select the desired foreground image from among the different foreground images displayed in numbered windows on the
10 touch screen 15 by touching the window containing the desired foreground image. The specific and overall methods performed by the embodiment of Fig. 2 are the same as those shown and described in Figs. 3, 4 and 6 and the preferred end product is the same as that shown
15 in Fig. 5.

A first alternate embodiment of the invention is shown in Fig. 7. In this alternate embodiment, the user is able to vary the appearance of his or her image vis-a-vis the selected foreground image. Specifically,
20 the keypad 18 is provided with four image adjustment keys 18a-18d, wherein key 18a provides a command signal for making the image smaller, key 18b provides a command signal for making the image larger, key 18c provides a command signal for making the image higher,
25 and key 18d provides a command signal for making the image lower. The camera 16, which preferably is a CCD (Charge Coupled Device) camera with digitally controlled power zoom feature, is mounted on a supporting tilt mechanism 72. The camera 16 receives
30 command signals from the keypad 18 through signal line 74, and the tilt mechanism 72 receives command signals from the keypad 18 through signal line 76.

In operation, when a user desires to make herself appear smaller in the image displayed on the monitor
35 14, she presses the key 18a. This causes a corresponding command signal to be sent to the camera 16 through line 74, which causes the zoom mechanism to

"zoom out" and thereby make the image of the user appear smaller on the monitor 14. Similarly, if the user desires to make herself appear larger in the displayed image, she presses key 18b, which causes a
5 corresponding command signal to be sent to the camera 16 which causes the zoom mechanism to "zoom in" on the user, making her image larger.

If the user wishes to make herself appear higher or lower in the image vis-a-vis the displayed
10 foreground, she presses the respective keys 18c or 18d. Actuation of these keys causes corresponding command signals to be sent to the tilt mechanism 72, which functions to tilt the camera 16 down or up, respectively, so that the user's image appears higher
15 or lower in the reference frame of the monitor 14.

After the user is finished adjusting the image, she may strike a pose and activate the image freeze function, which will cause the image to be "captured" and stored in memory for further processing and
20 printing.

Fig. 8 shows a block diagram of a second alternate embodiment for user interactive image adjustment. In this embodiment, the zoom feature and tilt mechanism are replaced by an electronic imaging process.
25 According to this embodiment, the image from the camera 16 is sent to the CPU 21 and is stored in a memory 21a associated with the CPU 21. Upon receipt of a command signal from the keypad 18 through signal line 82, the CPU 21 determines what command has been sent by the
30 content of the signal, i.e., whether the command is to make the user image smaller, larger, higher or lower in the composite image. Upon determining the command, the CPU may execute an image processing program to digitally manipulate the user image data stored in
35 memory 21a in order to obtain the desired adjustment. The modified image data is then sent to the monitor 14 for viewing by the user. According to this embodiment,

the user may adjust the image appearance after activating the image freeze capture function which causes the instantaneous image data from the camera 16 to be sent to the CPU and stored in memory. While the
5 embodiments of Figs. 7 and 8 have been described with respect to use of keys on a keypad 18, the image modifying keys equivalently may be implemented on a touch sensitive screen as referred to above.

10 The photo kiosk apparatus and method of the present invention thus present a user friendly direct view, menu driven interface which is easy to operate and which give results which can be composed and edited in advance of actual hard copy print out and which
15 further provide a unique end product in the form of a sticker sheet with removable image stickers having multiple uses. The term "direct view" as used herein to describe the photo kiosk of the present invention, refers to the open face presented by the kiosk with respect to the user wherein the viewing screen, the
20 opening of the optical path from the camera to the region for provided for the user to pose at the kiosk, and the associated keyboard and other operating controls, such as the touch screen features on the viewing screen, are all arranged directly in front of
25 and interfacing with the user in an open and unenclosed space directly in front of the apparatus. The term "freeze image" as used herein refers to an electronically stored image which is displayed on the screen for viewing by the user prior to the selection
30 of the image for hard copy print out by the printer.

35 It is to be understood that the embodiments of the apparatus and methods presented herein are shown and described for the purposes of making a full disclosure of the preferred embodiments and that the embodiments presented are thus not limiting in any way as to the scope of the present invention as defined in the appended claims.

WHAT IS CLAIMED IS:

1. A direct view photo kiosk for automatically taking, processing and delivering to a user in response to user-activated commands photographic images of the user posed at the photo kiosk comprising:
- 5 an electronic imaging device for electronically forming first electronic imaging information representative of an image of the user posed in a region provided at the photo kiosk for the user to pose;
- 10 a display for displaying an image represented by said first electronic imaging information;
- means for selectively modifying said first electronic imaging information displayed on said display so as to alter the size and/or orientation of
- 15 said image represented by said first electronic imaging information as displayed on said display according to commands selected by said user;
- a printer for printing out hard copy images responsive to electronic imaging information delivered
- 20 thereto;
- means for delivering said modified first electronic imaging information to said printer for printing out from said printer hard copy images represented by said modified first electronic
- 25 information; and
- delivery means for automatically delivering to said user said hard copy images.
2. A direct view photo kiosk as set forth in claim 1, wherein said electronic imaging device comprises a video camera including a power zoom device and said means for selectively modifying comprises a supporting
- 5 tilt mechanism for supporting said video camera within said photo kiosk, and a keypad for transmitting commands to said power zoom device and said tilt

mechanism to modify the size and orientation of said image represented by said first electronic imaging information on said display.

5 3. A direct view photo kiosk as set forth in claim 1 wherein said electronic imaging device comprises a video camera and said means for selectively modifying comprises an electronic processor including a memory for storing said first electronic imaging information from said camera and a keypad for transmitting commands to said electronic processor to modify the size and orientation of said image represented by said first electronic imaging information on said display.

4. A direct view photo kiosk as set forth in claim 1 in which said display comprises a touch sensitive screen for enabling the user to make a selection of a selected image of the user and an image foreground by touching a selected portion of the touch screen.

5 5. A direct view photo kiosk as set forth in claim 1, further comprising an electronic processor for processing said modified first electronic imaging information to form second electronic imaging information representative of multiple images of the image represented by said modified first electronic imaging information;

said multiple images being arranged in a preselected pattern for being printed by said printer as a hard copy on a single sheet.

6. A direct view photo kiosk as set forth in claim 5, wherein said second electronic information is printed out from said printer on a single multilayer hard copy sheet;

5 said single multilayer hard copy sheet being formed of a base sheet layer and an imaging sheet layer which are removably adhered together and formatted such that each of said multiple images can be separately peeled off from said supporting base sheet layer on

10 which all of said multiple images are adhesively
secured.

7. A direct view photo kiosk as set forth in claim 1
further comprising optical reflection means positioned
between the region provided for the user to pose and
said electronic imaging device for reflecting the image
5 of the user within said kiosk to form a folded and
extended length optical path to narrow the depth of
field within said region provided for the user to pose.

8. A direct view photo kiosk as set forth in claim 4
including means for displaying on said touch sensitive
screen images of the user with multiple foreground
images for touch selection by said user and means for
5 electronically incorporating the selected image of the
user and foreground image into said first electronic
imaging information.

9. A method for automatically taking, processing and
delivering to a user in response to user-activated
commands photographic images of the user posed at a
photo kiosk, comprising the steps of:

5 electronically forming first electronic imaging
information representative of an image of the user
posed in a region provided at the photo kiosk for the
user to pose;

10 displaying an image represented by said first
electronic imaging information;

15 selectively modifying said first electronic
imaging information displayed so as to alter the size
and/or orientation of said image represented by said
first electronic imaging information as displayed
according to commands selected by said user;

printing out hard copy images responsive to
electronic imaging information delivered thereto;

20 delivering said modified first electronic imaging
information to said printer for printing out from said
printer hard copy images represented by said modified
first electronic information; and

automatically delivering to said user said hard copy images.

10. A method as set forth in claim 9, wherein said step of selectively modifying comprises transmitting commands to a power zoom device of an electronic imaging device for forming said first electronic imaging information and to a tilt mechanism for supporting said electronic imaging device, to modify the size and orientation of said image represented by said displayed first electronic imaging information.

11. A method as set forth in claim 9 wherein said step of selectively modifying comprises transmitting commands to an electronic processor storing said first electronic imaging information in a memory thereof to
5 modify the size and orientation of the image represented by said first electronic imaging information.

12. A direct view photo kiosk for automatically taking, processing and delivering to a user in response to user activated controls photographic images of the user posed at the photo kiosk comprising:

5 an electronic imaging device for electronically forming, in response to a signal activated by a user, first electronic imaging information representative of an image of the user posed in a region provided at the photo kiosk for the user to pose;

10 optical reflection means positioned between the region provided for the user to pose and said electronic imaging device for reflecting the image of the user within said kiosk to form a folded and extended length optical path to narrow the depth of field within said region provided for the user to pose;

15 an electronic processor for electronically processing said first electronic imaging information to form second electronic imaging information representative of multiple images of the image represented by said first electronic imaging information;

20 said second electronic imaging information representing said multiple images being arranged in a preselected pattern for being produced in hard copy form on a single sheet;

25 a printer for printing out hard copy images responsive to electronic imaging information delivered thereto;

30 said electronic processor including means for delivering said second electronic imaging information to said printer for printing out from said printer on a single multilayer hard copy sheet said multiple images represented by said second electronic information; and

35 delivery means for automatically delivering to
said user said single multilayer hard copy sheet
containing said multiple images.

13. A direct view photo kiosk as set forth in claim 12
in which said region provided for the user to pose is
unenclosed and further comprising a display screen for
displaying an image of the user and image foregrounds
5 available for selection by the user, an optical path
opening for said folded optical path and a keyboard
operable by the user, said display screen, said optical
path opening and said keyboard all facing said
unenclosed region provided for the user to pose.

14. A direct view photo kiosk as set forth in claim 13
in which said display screen comprises a touch screen
for enabling the user to make a selection of a selected
image of the user and an image foreground by touching a
selected portion of the touch screen.

15. A direct view photo kiosk for automatically
taking, processing and delivering to a user in response
to user activated controls photographic images of the
user posed at the photo kiosk comprising:

5 an electronic imaging device for electronically
forming, in response to a signal activated by a user,
first electronic imaging information representative of
the user posed in a region provided at the kiosk for
the user to pose;

10 an electronic processor for electronically
processing said first electronic imaging information to
form second electronic imaging information
representative of multiple images of the image
represented by said first electronic imaging
15 information;

said second electronic imaging information
representing said multiple images being arranged in a
preselected pattern for being produced in hard copy
form on a single sheet;

- 20 a printer for printing out hard copy images responsive to electronic imaging information delivered thereto;
- said electronic processor including means for delivering said second electronic imaging information
- 25 to said printer for printing out from said printer on a single multilayer hard copy sheet said multiple images represented by said second electronic information;
- said single multilayer hard copy sheet being formed of a base sheet layer and an imaging sheet layer
- 30 which are removably adhered together and formatted such that each of said multiple images can be separately peeled off from said supporting base sheet layer on which all of said multiple images are adhesively secured; and
- 35 delivery means for automatically delivering to said user said single multilayer hard copy sheet containing said multiple images.
16. A direct view photo kiosk as set forth in claim 15 further comprising optical reflection means positioned between the region provided for the user to pose and said electronic imaging device for reflecting the image
- 5 of the user within said kiosk to form a folded and extended length optical path to narrow the depth of field within said region provided for the user to pose.
17. A direct view photo kiosk as set forth in claim 16 in which said display screen comprises a touch screen for enabling the user to make selections by touching a selected portions of the touch screen.
18. A direct view photo kiosk as set forth in claim 17 including means for displaying on said touch screen images of the user with multiple foreground images for touch selection by said user and means for electronically incorporating the selected image of the user and foreground image into said first electronic imaging information.

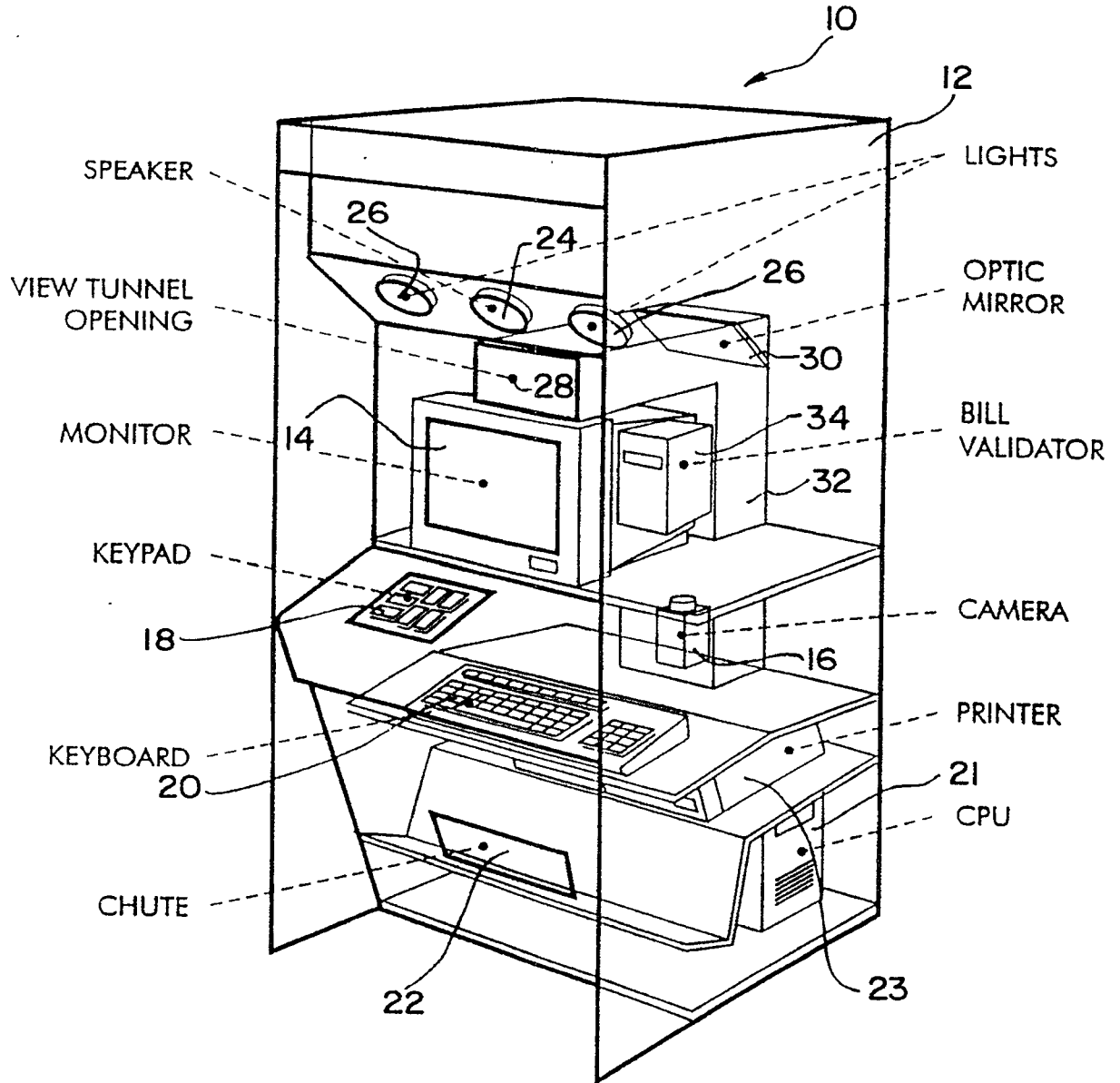

FIG. 1

2 / 7

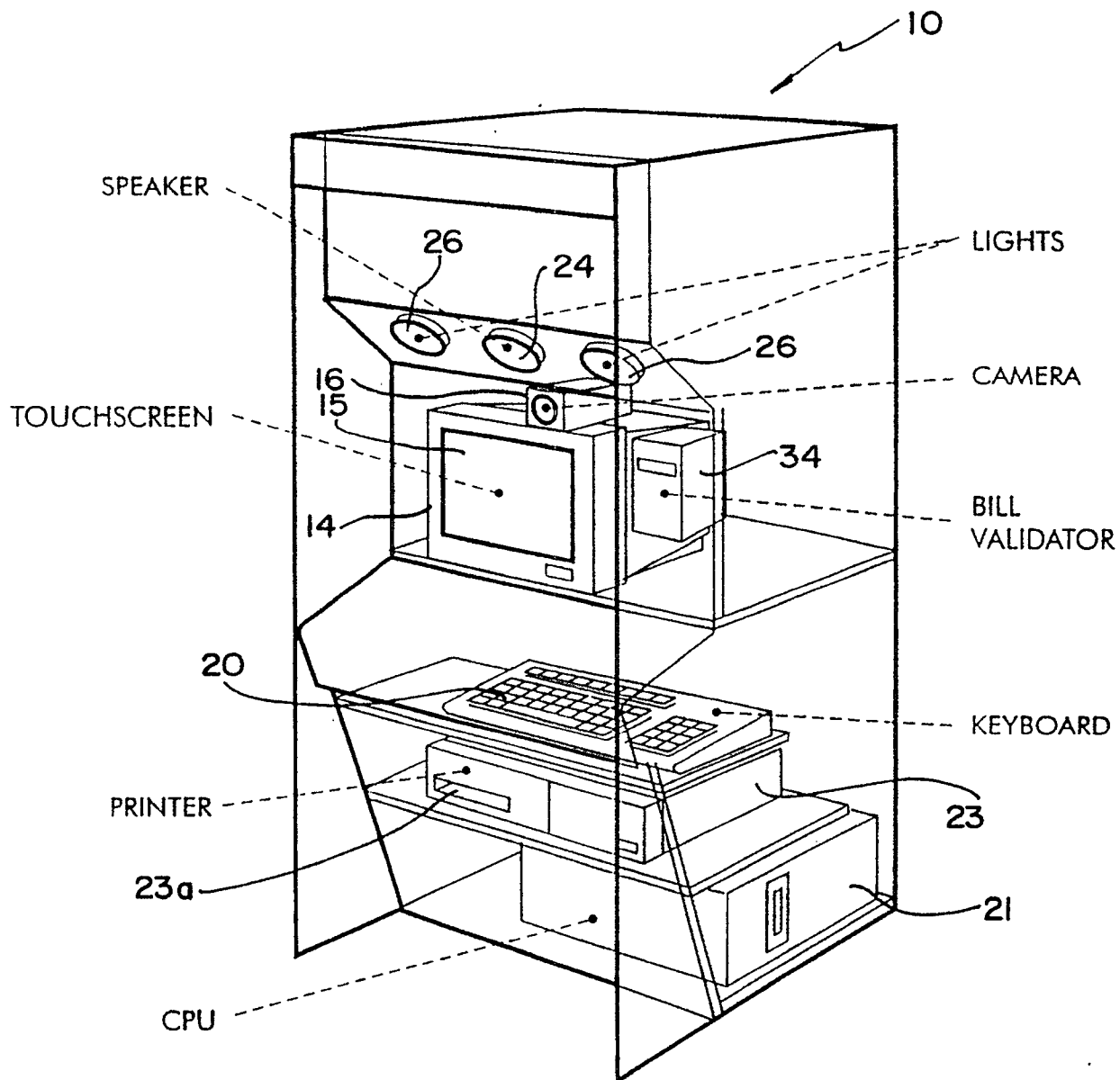

FIG.2

3 / 7

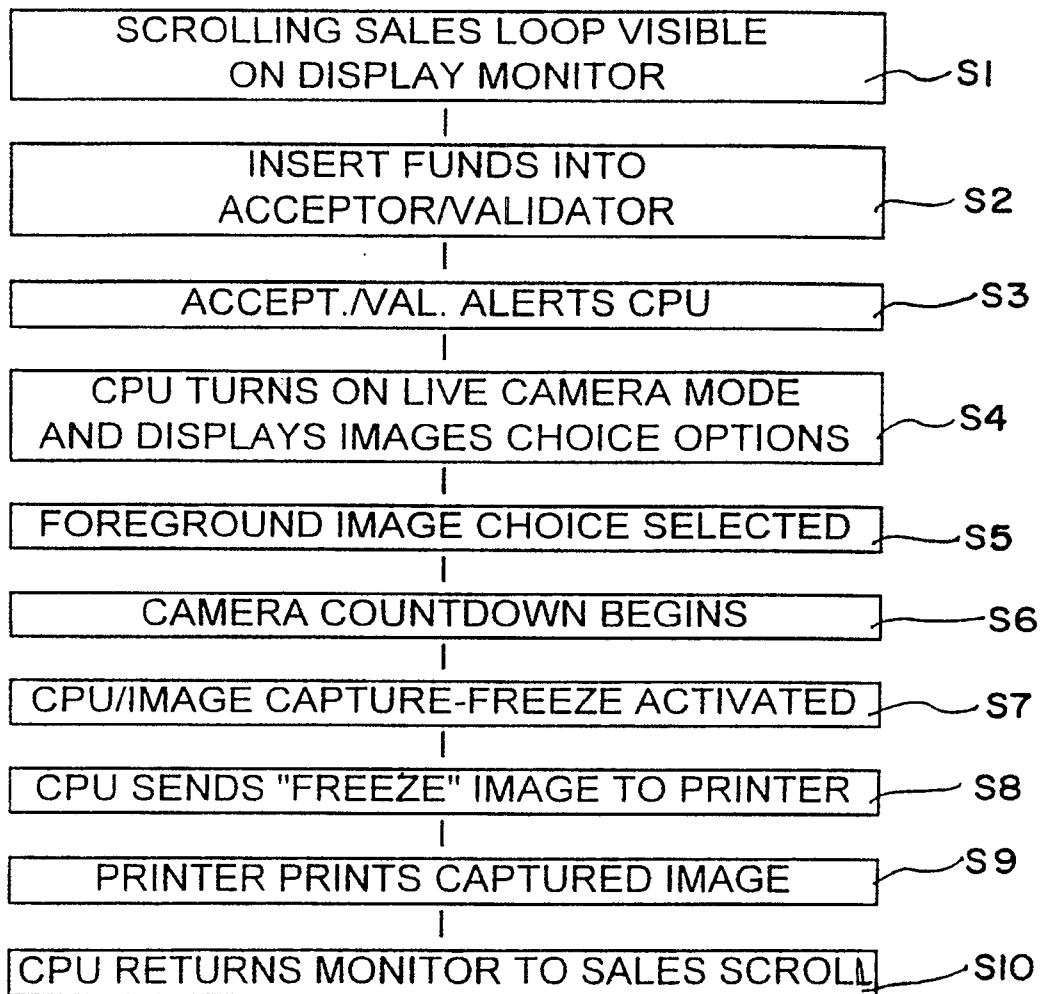

FIG.3

4 / 7

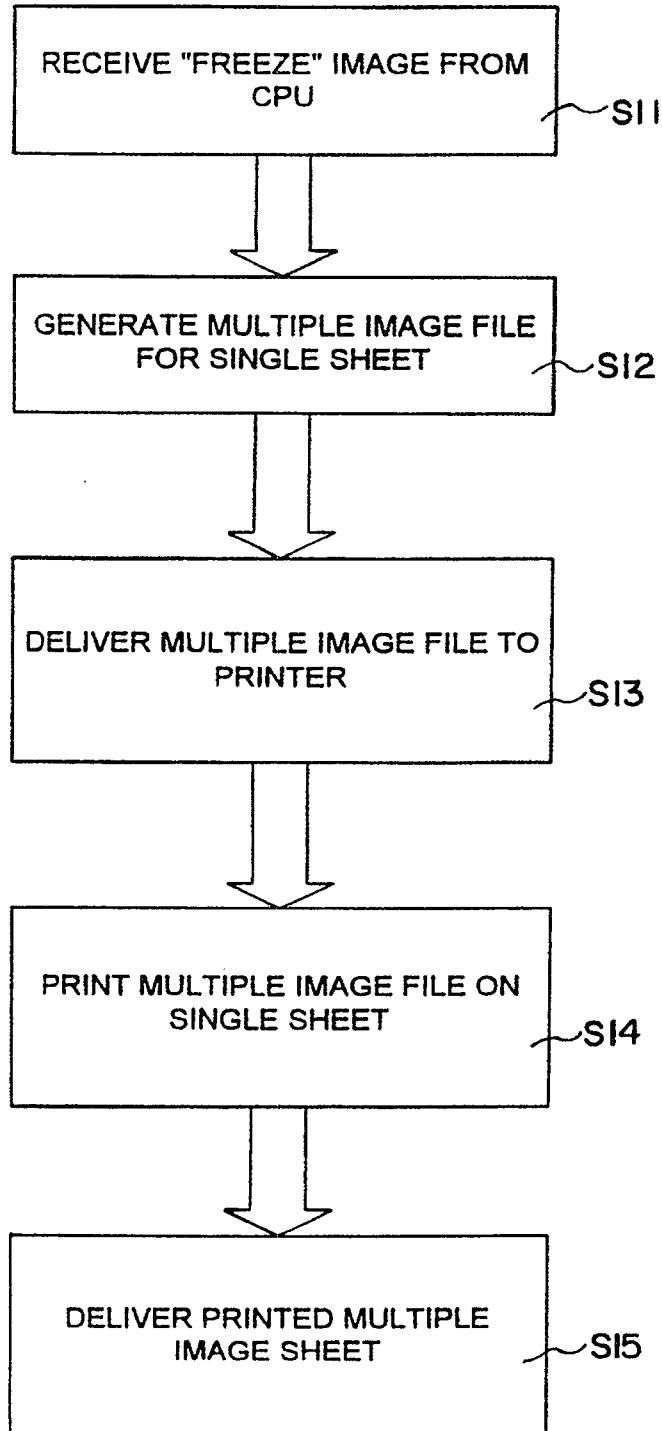

FIG.4

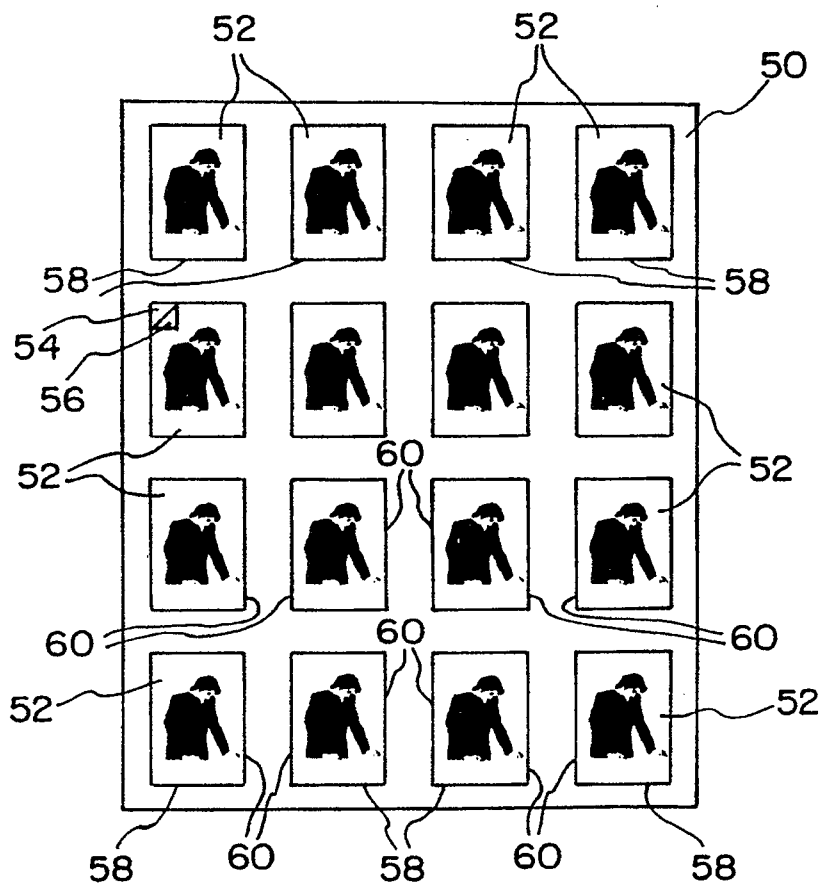

FIG.5

6 / 7

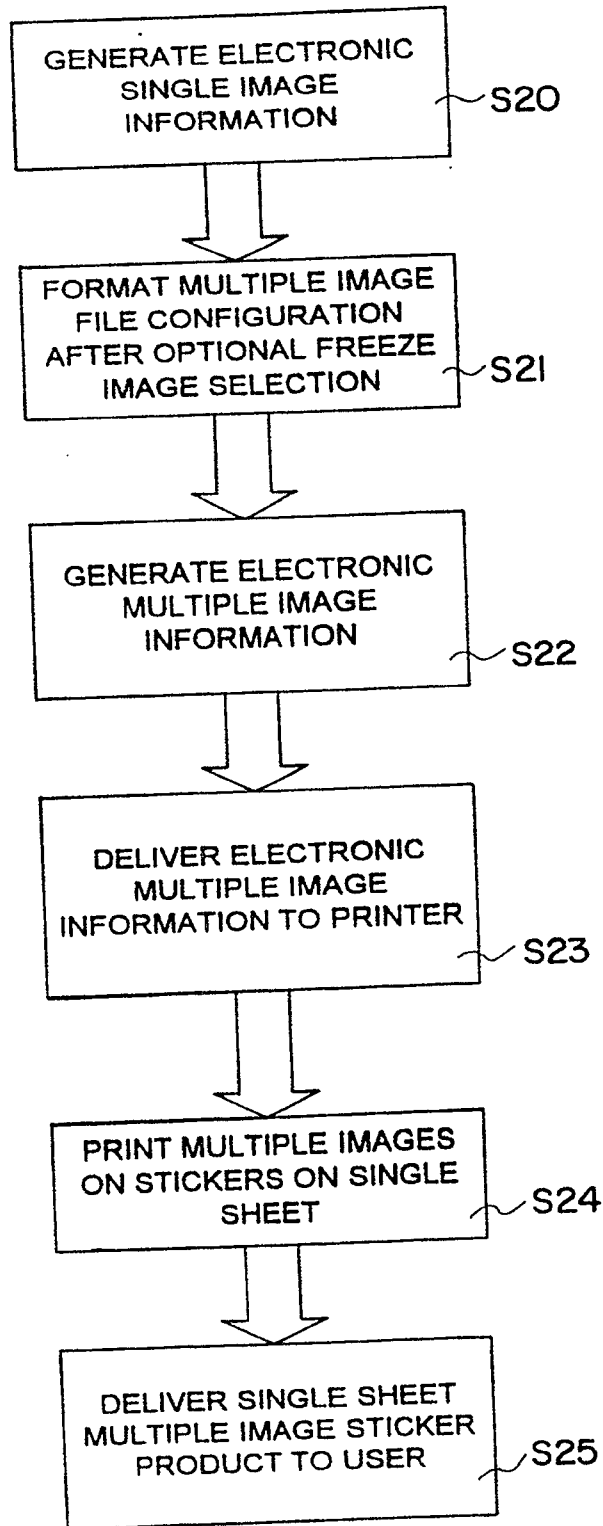

FIG. 6

2 / 2

FIG. 7

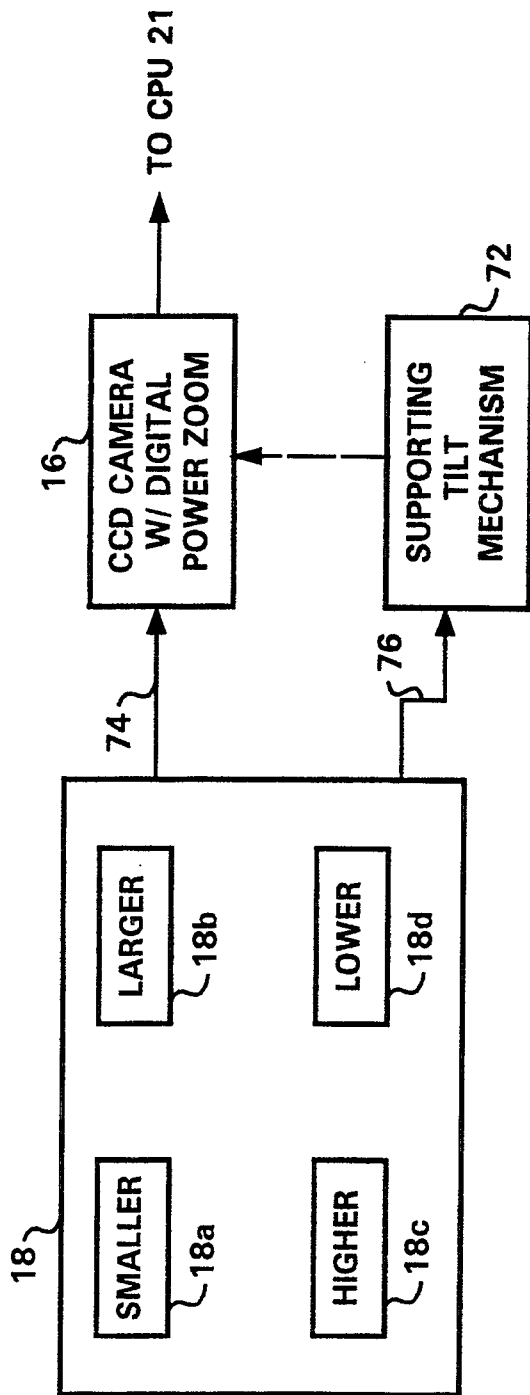

FIG. 8

