

[54] NESTABLE-STACKABLE RECEPTACLE

[75] Inventor: James D. Wilson, Newport Beach, Calif.

[73] Assignee: Banner Metals, Inc., Compton, Calif.

[22] Filed: June 11, 1973

[21] Appl. No.: 368,745

[52] U.S. Cl. 206/507; 206/511; 206/513; 206/821; 211/126; 220/19

[51] Int. Cl. B65d 21/04

[58] Field of Search 211/126, 128, 181, 71; 220/19; 206/503, 509, 511, 513, 507, 510, 512, 821; 108/51, 53, 55

[56]

References Cited

UNITED STATES PATENTS

2,622,830	12/1952	Coit, Jr.	206/503 X
2,666,552	1/1954	Coit, Jr.	206/513 X
2,803,369	8/1957	Fleetwood	220/19
3,022,900	2/1962	Averill	211/126
3,082,879	3/1963	Wilson	211/126
3,176,852	4/1965	Stovall	211/126
3,523,694	8/1970	Oliver	211/126 X
3,524,565	8/1970	Wilson	211/126 X

FOREIGN PATENTS OR APPLICATIONS

307,918	1/1969	Sweden	211/126
---------	--------	--------	---------

Primary Examiner—John W. Huckert

Assistant Examiner—Stuart S. Levy

Attorney, Agent, or Firm—Jessup & Beecher

[57]

ABSTRACT

An improved wire-formed receptacle is provided which may be stacked, or tiered, with other like receptacles when loaded with merchandise for transportation and display purposes, and which may be nested into other like receptacles when empty, for storage or for return to the distribution center with a minimum of space requirements. The improved receptacle of the invention is constructed to have particular utility, for example, in retail stores for restocking the shelves in such stores. The receptacles of the invention are constructed so that they may be shipped from the packing center, or warehouse, in a stacked condition as a multiplicity of static tiers; and which tiers may be conveniently elevated up from the floor or the retail store, or other facility, by a pallet jack, or the like, onto wheeled dollies for convenient movement about the facility.

2 Claims, 5 Drawing Figures

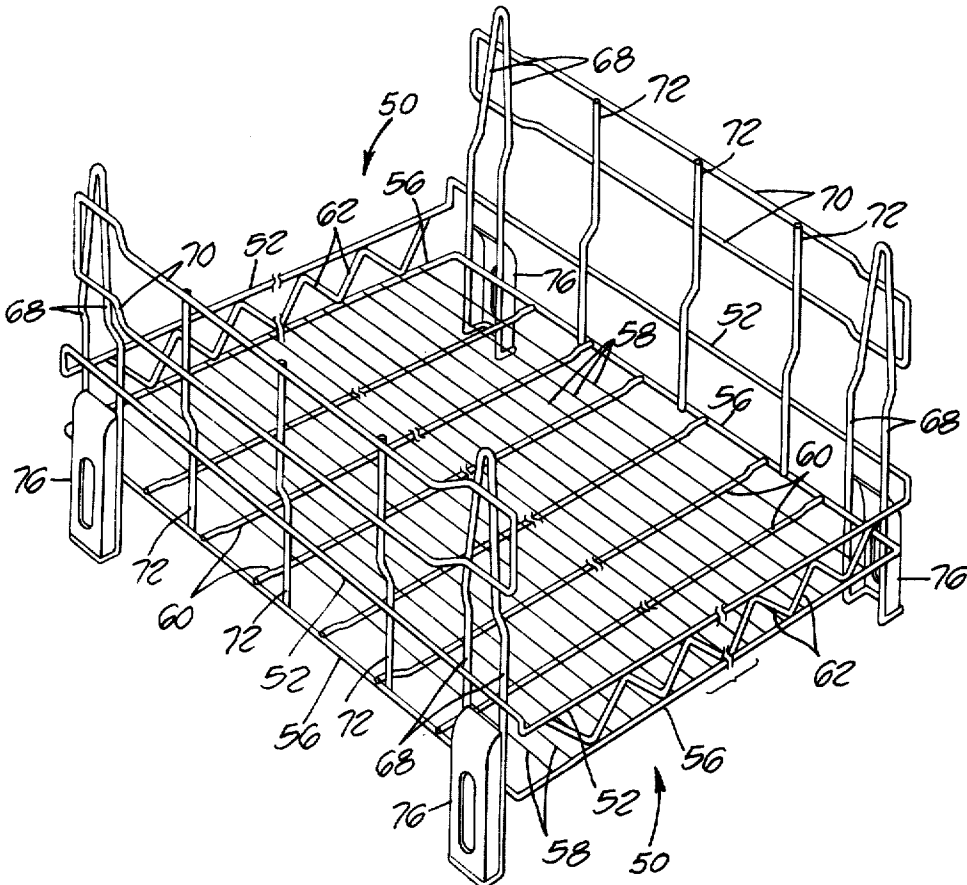

FIG. 1.

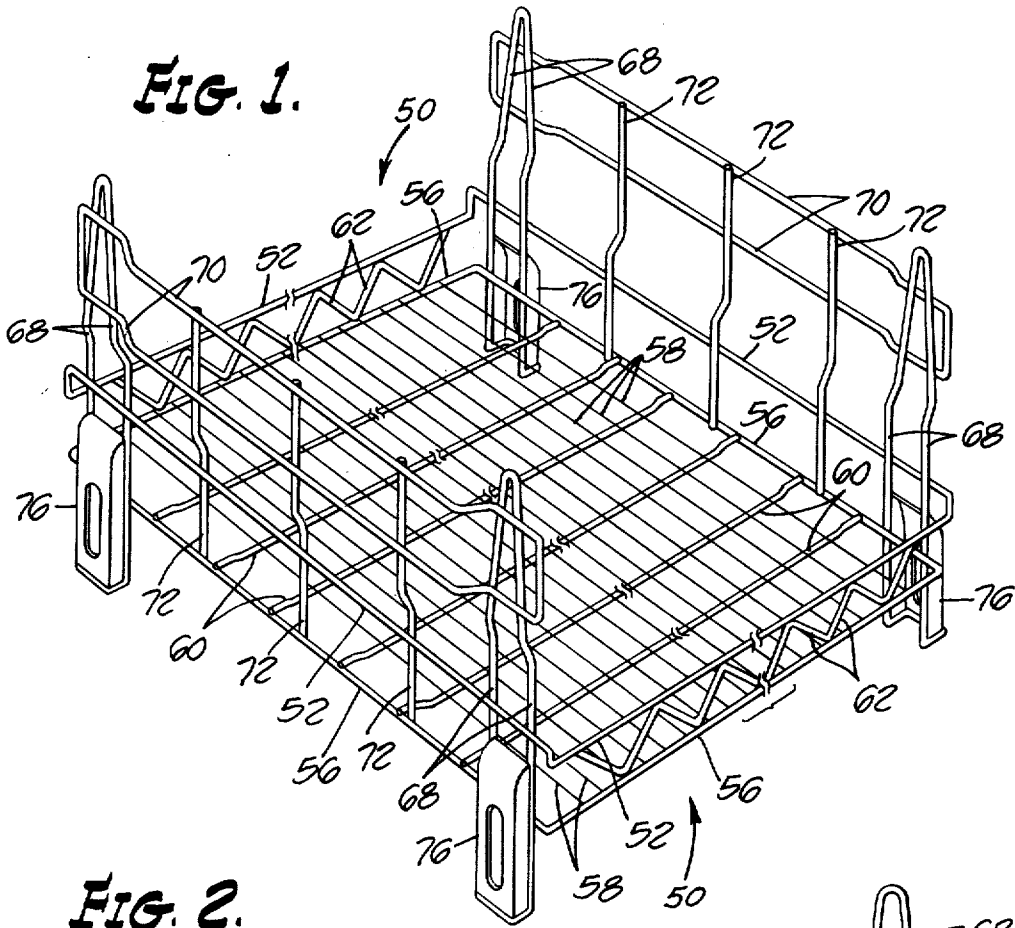

FIG. 2.

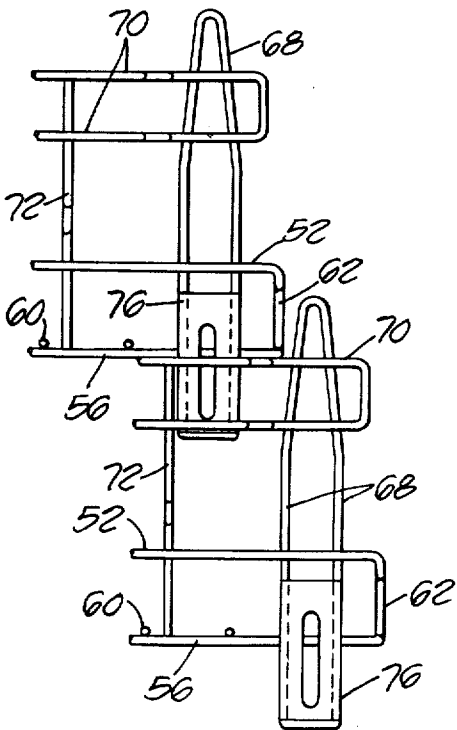
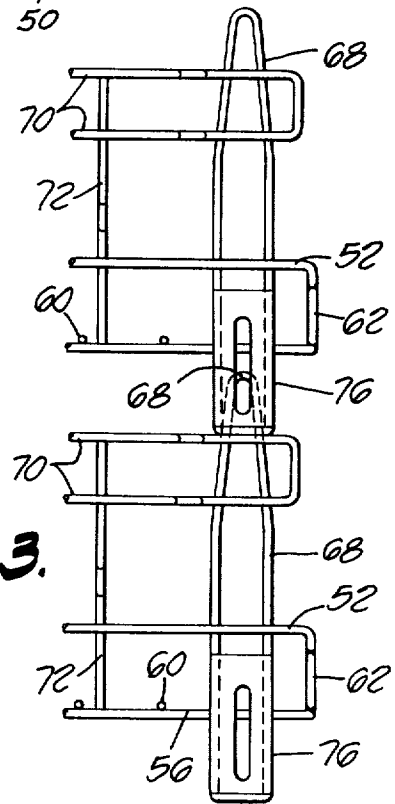

FIG. 3.



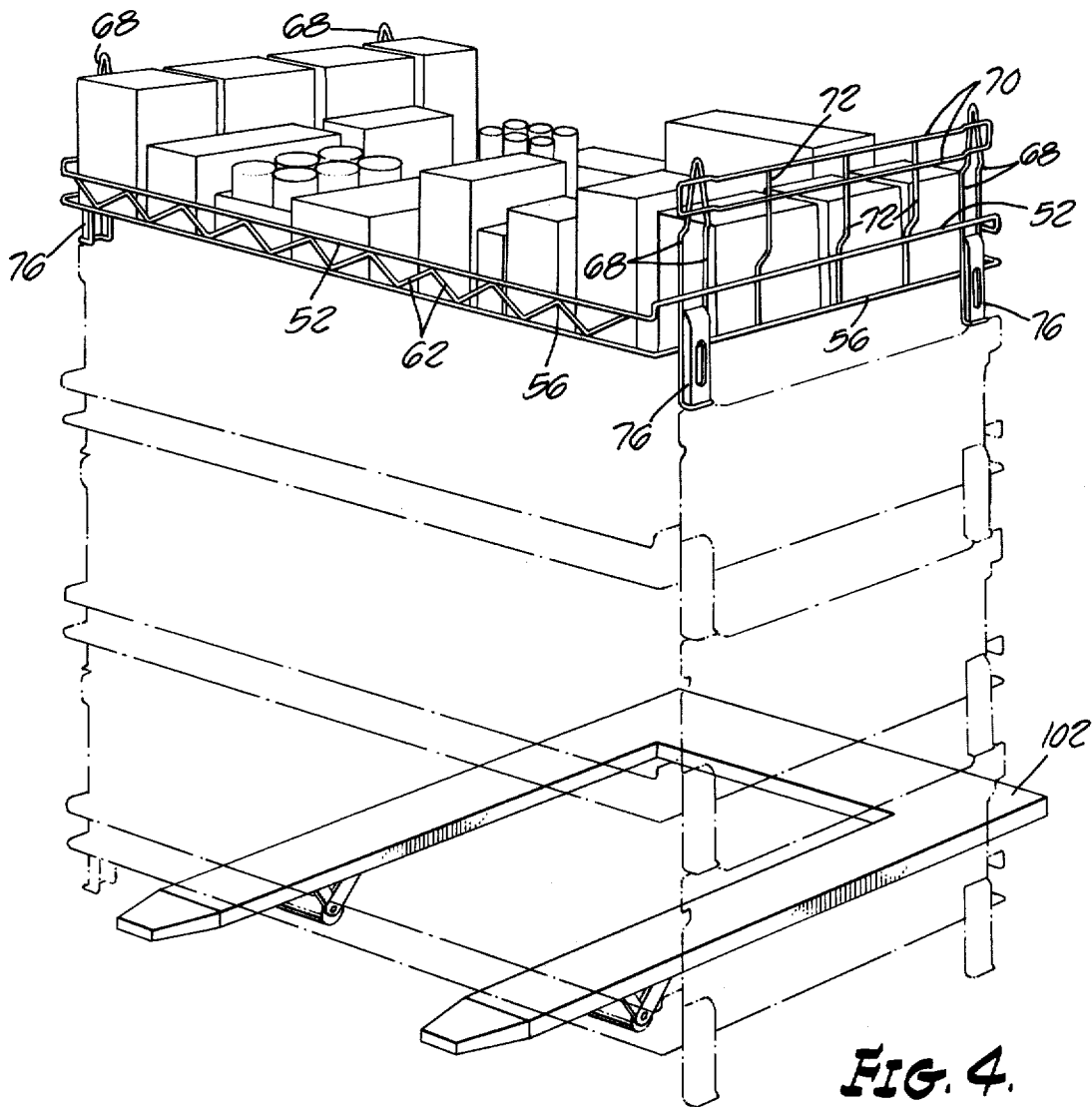

FIG. 4.

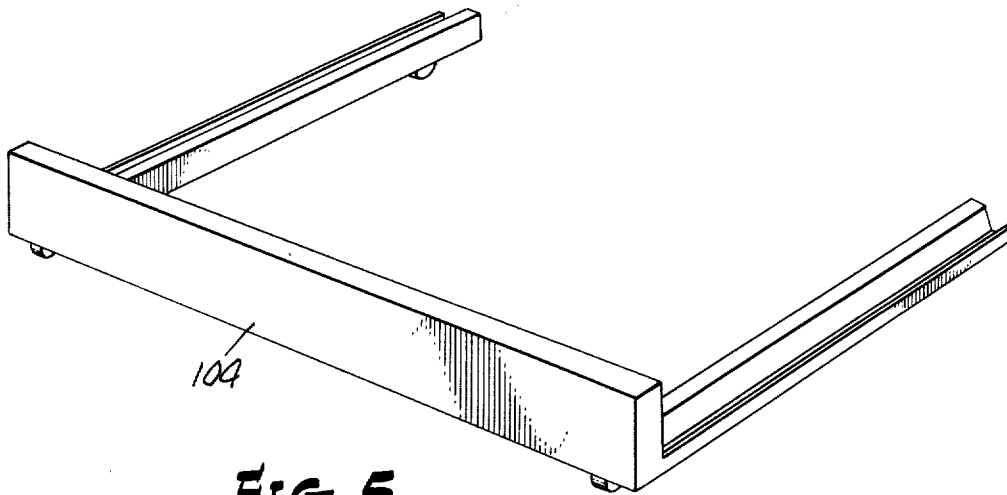

FIG. 5.

NESTABLE-STACKABLE RECEPTACLE

BACKGROUND OF THE INVENTION

U.S. Pat. No. 3,082,879, which issued Mar. 26, 1963 to the present inventor, describes a wire-formed tray or receptacle which is stackable and nestable, as is the receptacle of the present invention. As described in the patent, tiers of such receptacles are usually mounted on dollies, and the tiers of loaded receptacles are shipped from the packing plant, or warehouse, to the retail outlet, or other facility, in order that goods and commodities may be supplied to the facility.

A further U.S. Pat. 3,524,565 which issued Aug. 18, 1970 to the present inventor, also describes a similar type of wire-formed tray or receptacle which is stackable and nestable. The receptacles of the latter patent are generally similar to those described in the first patent, but are constructed to be appropriate for heavier loads. The latter receptacles, likewise, are intended to be shipped from the packing plant or warehouse in tiers supported on individual dollies.

In each instance, the tiers of receptacles described in the patents are mounted on dollies and are wheeled manually onto a truck, or other vehicle, at the packing plant or warehouse for shipment to the retail outlet. Then they are wheeled manually from the truck onto the loading dock and into the storeroom, or freezer, of the retail outlet. A major objection to this procedure is the need for a large number of dollies in order the transport the tiers of receptacles from the packing centers, or warehouses, to the retail outlets. Another objection is the fact that the tiers of receptacles in the transport trucks are not static, since they are supported on dollies, and they are free to roll around unless elaborate means are taken to restrain them.

An additional objection to the aforesaid procedure is the fact that a large number of dollies are used to transport the tiers of receptacles to the retail outlets and this results in an inordinate number of dollies at the retail outlets which have a tendency to become lost, or used for other purposes, thus entailing additional expense. Moreover, the dolly-supported tiers represent a problem in unloading the truck when the truck is on a slope, such as the case with most retail outlets which make use of a truck well.

It is clear, therefore, that the dolly-supported tier is a problem until it reaches the retail outlet. After the tier has been taken into the outlet, however, the dolly is then essential, since it permits the personnel of the retail outlet to wheel the tiers of receptacles into the various areas where they are needed. The receptacles of the present invention overcome this problem since they are constructed so that they can be stacked into a static tier which is supported up from the floor on legs to permit either a fork truck or a pallet jack to slip under the tier and raise it up for moving about the packing center, warehouse, into the trucks, and off the trucks into the retail store.

While the tiers of receptacles of this invention are on the trucks, however, they are static, and can easily be restrained from movement as they are transported to the retail outlet. Once they are unloaded from the truck into the retail outlet, a pallet jack may be slipped under the individual tiers to raise it up from the floor, and to permit a dolly to be slipped under the stack, so that it

may then be conveniently moved from place-to-place within the outlet.

Therefore, by the use of the particular receptacle construction of the present invention, the use of dollies is eliminated everywhere except where they are actually needed, and that is on the floor of the retail outlet. The configuration of the receptacles of the invention permit a static tier of the receptacles to exist up until the time the tier is actually deposited on the floor in the storeroom of the retail outlet. At that time, the store personnel will roll a standard pallet jack under the tier and raise it up, so that a U-shaped dolly may be inserted from the opposite side. Then, the pallet jack may be lowered, to transfer the tier onto the dolly. The pallet jack may then be removed, and the tier of receptacles may be easily moved on the dolly about the store, until the receptacles of the tier have served their purpose of stocking the shelves, etc., in the stores. When the receptacles are empty, the pallet jack is again inserted under the empty tier to remove the dolly, and replace the tier back on the floor as a static tier. The receptacles may then be nested down for pick-up by the truck driver on his next round.

The receptacles of the invention are similar in construction to the receptacles of the U.S. Pat. No. 3,524,565. However, they have an additional elongated projection at the lower corners which displace the lower horizontal wire loops down from the bottom of the receptacle. In this way, when the receptacles of the invention are stacked on one another, the resulting tier is displaced up from the floor, so as to permit a pallet jack, or the like, to lift up the tier to deposit it one a dolly, at the retail outlet, as described above.

As in U.S. Pat. No. 3,524,565, the construction of the individual receptacles of the present invention is such that, when the receptacles are stacked on top of one another into a tier, they are held firmly in place, so as to constitute a stable assembly. Also, each receptacle of the present invention, as is the case with the receptacles in both the aforesaid patents, may be nested down into a lower receptacle, merely by displacing it longitudinally with respect to the lower receptacle, and permitting it to move down into the lower receptacle.

The receptacles of the present invention, like the receptacles of U.S. Pat. No. 3,524,565, are constructed so that an upstanding elongated looped wire side bracket extends from each horizontal bottom loop of the receptacle to the corresponding upstanding upper projection. With such construction, any load supported on the upper projection of the receptacle is directly supported by the compressive stress of the corresponding side brackets, and no bending stress or strains are relied on for load support. In addition, metal brackets are welded, or otherwise attached to each of the upstanding elongated looped wire side brackets for further reinforcing purposes.

BRIEF DESCRIPTION OF THE DRAWINGS

FIG. 1 is a perspective view of a receptacle constructed in accordance with the concepts of the invention;

FIG. 2 is a partial side elevation showing two receptacles, of the type illustrated in FIG. 1, preliminarily to being nested within one another;

FIG. 3 is a side elevation showing a partial view of two receptacles, of the type illustrated in FIG. 1, stacked on top of one another;

FIG. 4 is a perspective representation of a tier of receptacles, such as the receptacle of FIG. 1, supported on a pallet jack; and

FIG. 5 is a perspective representation of a U-type shelf dolly which may be used to support the tier in FIG. 4 in the place of the pallet jack.

DETAILED DESCRIPTION OF THE ILLUSTRATED EMBODIMENT

The receptacle indicated in FIG. 1 is indicated generally as 50. In the receptacle 50, an intermediate wire rod 52 extends as a closed rectangular loop around the periphery of the receptacle. The closed rectangular loop formed by the wire rod 52 has spaced and parallel end portions, as shown, and it also has spaced and parallel side portions. The side portions of the loop formed by the wire rod 52 are displaced down from the merchandise to be inserted into and withdrawn from the receptacle, especially when it is stacked on other like receptacles, and yet form a barrier to prevent the merchandise from sliding out the sides of the receptacle.

A further wire rod 56 extends around the periphery of the receptacle 50 at the bottom of the receptacle, and the wire rod 56 forms a support for bottom wires 58 which extend from one side of the receptacle to the other in spaced and parallel relationship, and which are welded to the side portions of the wire rod 56. The wire rod 56 also forms a support for longitudinal rods 60 which are of somewhat larger diameter than the bottom wires 58, and which serve to reinforce the bottom. The rods 60 extend longitudinally from one end of the bottom to the other, and are welded, or otherwise attached, to the end portions of the wire rod 56. A plurality of V-shaped individual wire rods 62 extend between the side portions of the wire rod 52 and of the wire rod 56, so as to complete the barrier.

The upper and lower supports for the receptacle 50 are formed by V-shaped wire rods 68 of relatively large diameter. These rods are each folded back on one another to form an upper mounting projection at each corner of the receptacle, and the rods 68 are bent over into a horizontal loop at their lower ends, to form the looped lower support members. As shown, each of the wire rods 68 extends below the bottom of the receptacle 50, so that the lower support members are each displaced down from the plane of the bottom into a second plane spaced and parallel below the bottom plane. In addition, a sheet metal bracket 76 is welded, or otherwise attached to the lower end of each of the rods 68 as an additional reinforcing means.

The ends of the receptacle are formed by wire rods 70 which extend as closed loops between the upright rods 68 at both ends of the receptacle, and which are welded, or otherwise affixed to the rods 68. In addition, upright rods 72 are welded to the rods 70 and to the rods 52 and 56 to complete the end structures. The rods 68 provide a positive support between the receptacles of the tier, even when loaded with heavy merchandise, and, together with the additional reinforcing brackets 76, permit merchandise of substantial weight to be placed in each receptacle of the tier without any tendency for the receptacles to collapse or bend.

As best shown in FIG. 2, for example, the receptacle of FIG. 1 may be nested down into a similar receptacle,

merely by displacing it slightly from the lower receptacle as shown in FIG. 2, and subsequently dropping it into place into the lower receptacle. Likewise, the receptacle of FIG. 1 may be stacked on a lower receptacle to form a tier, the stacking being accomplished, as shown in FIG. 3, by engaging the upper projection of the rod 68 of a lower receptacle with the looped lower support member of the corresponding rod 68 of the upper receptacle.

As shown in FIG. 4, a tier of receptacles of the type shown in FIG. 1 may be conveniently placed on a pallet jack 100, merely by slipping the pallet jack under the lowermost receptacle 50, which is displaced up from the floor by the lower extensions of the rods 68, the pallet jack may then be controlled to its upper level, so as to lift the tier up off the floor and permit a U-shaped shelf dolly 104, as shown in FIG. 2, to be conveniently slipped under the tier as a mobile support means.

The invention provides, therefore, an improved receptacle which is nestable and stackable, and which includes side brackets interposed between its upper and lower support members. The side brackets are extended, so that the receptacles are displaced from one another when formed into a tier, and are also displaced up from the floor of the supporting surface, to permit a pallet jack, or the like, conveniently to be slipped under the tier, to enable it to be loaded in a dolly, for the reasons described above.

While a particular embodiment of the invention has been shown and described, modifications may be made. It is intended in the claims to cover the modifications which fall within the spirit and scope of the invention.

What is claimed is:

1. A receptacle capable of being stacked or nested with receptacles of like construction, including: a first wire rod extending as a closed rectangular loop around the periphery of the receptacle, said closed rectangular loop having spaced and parallel side portions, having spaced and parallel end portions, and having four corners; means attached to said wire rod to define a bottom for the receptacle; and further wire rods forming elongated side brackets attached to said wire rod at the respective corners of the rectangular loop, said side brackets extending upwardly to define corresponding upper support members displaced downwardly from the plane of the bottom of the receptacle and extending downwardly to define corresponding lower support members displaced downwardly from the plane of the bottom and in respective vertical alignment with the upper support members, each of said further wire rods defining an inverted U-shape to provide an apex at the upper end of the corresponding side bracket, and each of the further rods being formed with the lower end thereof configured into a bent-over looped end portion.

2. The receptacle defined in claim 1, and which includes an elongated stamped sheet metal bracket having an essentially solid rectangular configuration affixed in an upright position to each of said further rods at the lower end thereof with the lower end of the bracket positioned on top of and in engagement with said bent-over looped end portion thereof.

* * * * *