

CORRECTED VERSION

(19) World Intellectual Property Organization  
International Bureau



(43) International Publication Date  
3 July 2008 (03.07.2008)

PCT

(10) International Publication Number  
WO 2008/080023 A8

(51) International Patent Classification:

B41J 2/145 (2006.01) B41J 29/393 (2006.01)  
B41J 2/15 (2006.01) B41J 2/14 (2006.01)  
B41J 29/38 (2006.01)

(21) International Application Number:

PCT/US2007/088458

(22) International Filing Date:

20 December 2007 (20.12.2007)

(25) Filing Language:

English

(26) Publication Language:

English

(30) Priority Data:

60/871,701 22 December 2006 (22.12.2006) US

(71) Applicant (for all designated States except US): FUJIFILM DIMATIX, INC. [US/US]; 109 Etna Road, Lebanon, New Hampshire 03766 (US).

(72) Inventors; and

(75) Inventors/Applicants (for US only): VON ESSEN,

Kevin [US/US]; 5074 Trenary Way, San Jose, California 95118 (US). HIGGINSON, John, A. [US/US]; 2826 Forbes Avenue, Santa Clara, California 95051 (US). BIBL, Andreas [US/US]; 588 Harrington Avenue, Los Altos, California 94024 (US). GARDNER, Deane, A. [US/US]; 22321 Cupertino Road, Cupertino, California 95014 (US). ROCCHIO, Michael [US/US]; 2542 Jacobs Street, Hayward, CA 94541 (US). DEMING, Stephen, R. [US/US]; 1020 Fourier Drive, San Jose, California 95127 (US).

(74) Agent: LEEDS BINDER, Brenda, M.; Fish & Richardson P.C., P.O. Box 1022, Minneapolis, Minnesota 55440 (US).

(81) Designated States (unless otherwise indicated, for every kind of national protection available): AE, AG, AL, AM, AT, AU, AZ, BA, BB, BG, BH, BR, BW, BY, BZ, CA, CH, CN, CO, CR, CU, CZ, DE, DK, DM, DO, DZ, EC, EE, EG, ES, FI, GB, GD, GE, GH, GM, GT, HN, HR, HU, ID, IL, IN, IS, JP, KE, KG, KM, KN, KP, KR, KZ, LA, LC, LK,

[Continued on next page]

(54) Title: ADJUSTABLE MOUNT PRINTHEAD ASSEMBLY

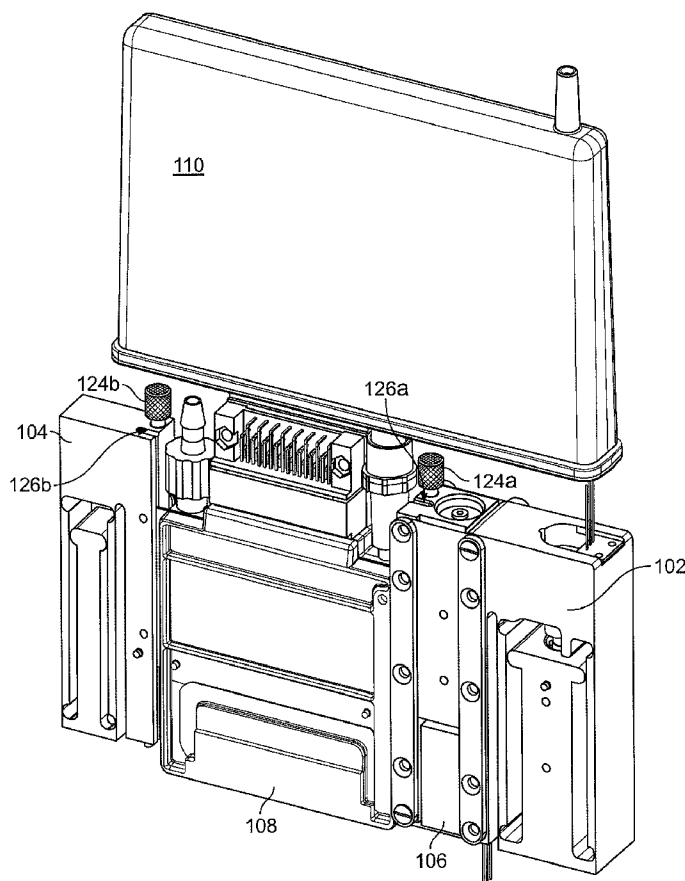

(57) Abstract: In the field of an ink jet printer with multiple printheads, it can be necessary to precisely position nozzles relative to a substrate, where the nozzles are included in the printheads. It can be difficult to achieve a precision printing, unless the nozzles are precisely aligned relative to one another, if multiple printheads are used to print contemporaneously. A mounting assembly for a printhead assembly includes one or more active direction mounts, which can control the position of the printhead in one or more directions. It can allow dynamic nozzle and drop placement adjustment in one or more directions.

WO 2008/080023 A8



LR, LS, LT, LU, LY, MA, MD, ME, MG, MK, MN, MW, MX, MY, MZ, NA, NG, NI, NO, NZ, OM, PG, PH, PL, PT, RO, RS, RU, SC, SD, SE, SG, SK, SL, SM, SV, SY, TJ, TM, TN, TR, TT, TZ, UA, UG, US, UZ, VC, VN, ZA, ZM, ZW.

- (84) Designated States** (*unless otherwise indicated, for every kind of regional protection available*): ARIPO (BW, GH, GM, KE, LS, MW, MZ, NA, SD, SL, SZ, TZ, UG, ZM, ZW), Eurasian (AM, AZ, BY, KG, KZ, MD, RU, TJ, TM), European (AT, BE, BG, CH, CY, CZ, DE, DK, EE, ES, FI, FR, GB, GR, HU, IE, IS, IT, LT, LU, LV, MC, MT, NL, PL,

PT, RO, SE, SI, SK, TR), OAPI (BF, BJ, CF, CG, CI, CM, GA, GN, GQ, GW, ML, MR, NE, SN, TD, TG).

**Published:**

— *with international search report*

- (48) Date of publication of this corrected version:**

2 July 2009

- (15) Information about Correction:**

see Notice of 2 July 2009