

May 31, 1938.

C. A. ADAMS

2,119,146

ELECTRIC LIGHT SOCKET AND SWITCH

Filed Dec. 7, 1933

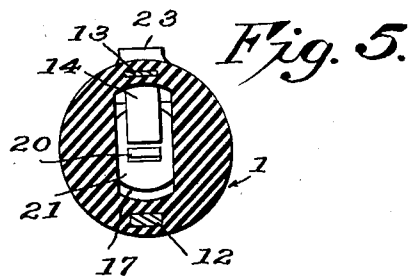
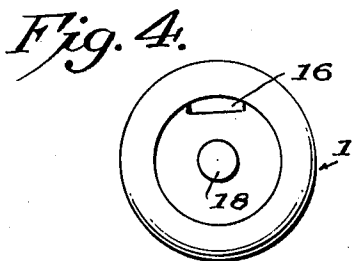
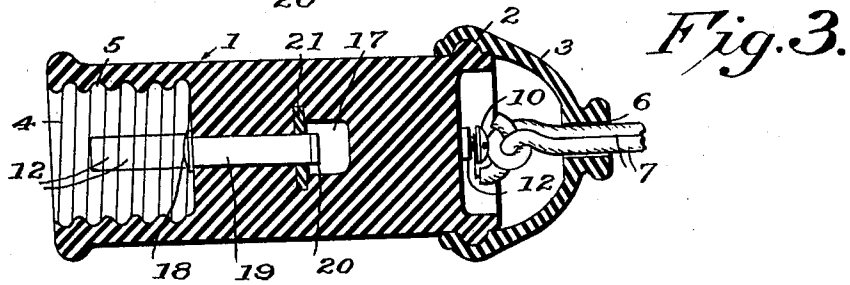
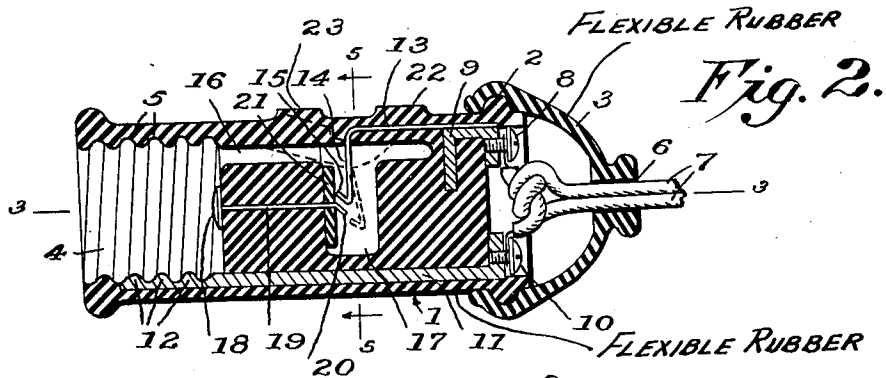
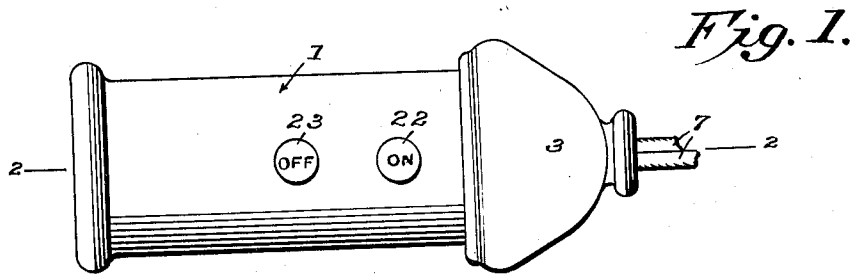

Inventor
Charles A. Adams.

By Louis Block.

Attorney

UNITED STATES PATENT OFFICE

2,119,146

ELECTRIC LIGHT SOCKET AND SWITCH

Charles A. Adams, Davenport, Iowa

Application December 7, 1933, Serial No. 701,393

4 Claims. (Cl. 173—355)

My invention relates to new and useful improvements in a combined electric light bulb socket and switch and has for its principal object the provision of a device of this character in which the body portion, or what may be termed the casing, is formed entirely of flexible rubber which prevents breaking by dropping or the like and at the same time prevents danger of shock to the user as no metal parts are exposed.

A further object of the invention consists in forming the body or casing of flexible rubber and including in said formation members adapted to be engaged for closing the contact members of the switch or releasing the same, said closing or opening of the contacts being accomplished by flexing of the body or casing.

Another object of the invention resides in the provision of a device of the character described in which the threads for receiving the electric light bulb shank are molded in the body or casing as an integral part thereof and in which the conductor members are embedded within the body or casing, one of the conductor members being formed with a portion cooperating with the molded threads.

With the above and other objects in view, which will appear as the description proceeds, my invention consists in the novel details of construction, and arrangement of parts, described in the following specification and illustrated in the accompanying drawing, and while I have illustrated and described the preferred embodiments of the invention, as they now appear to me, it will be understood that such changes may be made as will fall within the scope of the appended claims.

In the drawing:—

Fig. 1 is a plan.

Fig. 2 is a longitudinal section on the line 2—2 of Fig. 1.

Fig. 3 is a longitudinal section on the line 3—3 of Fig. 2.

Fig. 4 is an end view looking in the direction of the threaded socket; and

Fig. 5 is a transverse section on the line 5—5 of Fig. 2.

In the drawing 1 indicates the body portion or casing formed of flexible rubber, provided at one end with the bead 2 to receive the flexible rubber cap 3 and at its opposite end with a socket 4 in which are molded the threads 5, the socket receiving the threaded shank of an electric light bulb, not shown, in the usual manner. The cap 3 is formed with a passage 6 through which extend the wires 7, the end of one of the wires being connected by means of the screw 8 to the metal member 9 embedded in the rubber body portion as shown more particularly in Fig. 2 of the drawing, while the other wire is connected by means of the screw 10 to the metal strip or plate 11 also embedded in the rubber body, the member 11 being of elongated form and extending

within the socket 4 with its end terminating, as shown more particularly in Figs. 2 and 3 of the drawing, within the socket or in other words not extending to the end of the body portion or casing. That end of the elongated strip 11 which extends into the socket 4 is formed with the ribs or raised portions 12 which form continuations of the threads 5 of the socket. The metal member 9 and strip 11 are preferably of brass and in electrical contact with the metal member 9 by welding, solder or otherwise is a metal strip 13 which, as shown more particularly in Fig. 2 is embedded in the member forming the body or casing and at its inner end is bent at right angles to provide the extension 14 formed on its end with the hook 15 for a purpose to be later described. The metal members or strips 9 and 11 act as conductors.

The body portion or casing is formed interiorly with the longitudinally extending recess 16 and extending transversely from this recess and communicating therewith is a second recess or passage 17 in which projects the extension 14 of the strip 13.

Positioned at the inner surface or bottom of the socket 4 is the metal contact member 18 having the extension 19 projecting inwardly through the body portion with its end projecting into the recess or passage 17 and bent at an angle as shown at 20 to provide a hook portion adapted to be engaged by the hook portion 15 in a manner to be later described, the hook portions 15 and 20 serving as contact members for closing a circuit. A fibre plate 21 is positioned, as shown, within the recess or passage 17 and the extension 19 of the contact member 18 passes through this plate and the plate in itself acts as a bearing surface for engagement by the hook 15 on the extension 14 of the strip 13 and thereby prevents wear of the rubber from the body.

Molded as a part of the body or casing 1 are the raised or projecting portions 22 and 23 forming buttons for the operation of the switch in a manner to be later described.

It is thought that the construction will be clearly understood from the above detailed description. While the combined socket and switch is primarily intended for use on the end of a light cord or the like it will nevertheless be understood that it might equally as well be used in any place where a light bulb socket or switch is desired and by presenting no metal surfaces for engagement by the hand or body of the user it will be understood that danger of shock is eliminated. A device of the character described will be of considerable advantage in use in machine shops or garages where it is often necessary to hang the light over metal parts of a machine, automobile or the like, and where metal portions of the socket or switch are exposed there is danger of

shock or short circuits. With my construction only rubber will engage any of the surfaces of the machines or automobiles or the like and only rubber surfaces will be engaged by the user.

5 Therefore, as previously stated, there will be no danger whatsoever of shocks or short circuits. The invention herein set forth is not limited to the specific form of socket illustrated and described but can be used wherever electric sockets

10 are to be opened and closed. The body portion 1 as well as the cap 3 may be formed in any suitable manner such as by molding and, if desired, the body may be molded in two halves, the metal contact members and connections positioned in

15 any suitable manner, and the two halves then vulcanized together. However, it will be understood that I do not wish to be limited to any particular manner of forming the body or cap and the parts may be assembled in such a manner as may be

20 found most convenient.

Normally the parts are in the positions shown more particularly in Fig. 2 of the drawing and the circuit will be broken so that the bulb will not be lighted. When it is desired to light the

25 bulb the user will press upon the projection or button 22 thereby flexing the side wall of the body or casing 1 so as to move the hooked end 15 of the extension 14 of the strip 13 inwardly to engage the hooked end 20 of the extension 19 of the contact 18 and this will close the circuit, it being understood that a contact on the end of the threaded shank of the light bulb, not shown, will engage the contact 18. The hooked end 15 will remain in engagement with the hooked end 20

30 as long as it is desired that the light remain on and the tendency of the wall of the body or casing to return to its normal position will hold the hooked end 15 into tight engagement with the hooked end 20. It will be understood that the

35 recess 16 in the body or casing permits a portion of the wall to be flexed when pressure is applied to the projections or buttons 22 or 23. When it is desired to break the circuit, or to release the hooked end 15 from the hooked end 20 the button or projection 23 will be pressed inwardly to move the wall of the body or casing into the position shown by dotted lines in Fig. 2 and such movement and positioning will swing the extension 14 of the strip 13 at an angle, as shown in dotted lines in Fig. 2, and disengage the hooked end 15 from the hooked end 20. Then as pressure is removed from the projection or button 23 the wall of the body will return to its original position pulling with it the hooked end 15 and return the same to its normal position shown in Fig. 2

40 of the drawing. When the hook member 15 is engaged with the hook 20, as previously stated, the circuit is closed, current passing from one of the wires 7 through the member 9, strip 13, extension 14, hook 15, hook 20, extension 19, and button 18 to the shank of the light bulb and from said shank through the strip or member 11 back into the other wire 7.

Having fully described my invention what I claim as new and desire to secure by Letters Patent is:—

1. An electric switch comprising a body portion of readily flexible insulating material including an interior block and an exterior housing for completely enclosing switch elements, the block and housing being formed for the accommodation of co-acting switch elements, and said switch elements being confined within the housing and

respectively mounted on the block and housing, a part of the housing being adapted to be flexed to effect operation of the switch, the housing having an exterior recess at one end for wire terminals, a flexible cap provided with a passageway for the wires leading and connected to said terminals fitted with the recessed end portion of the housing, and means forming connection between one of said wire terminals and switch elements.

2. A combined switch and socket comprising a housing formed of readily flexible insulating material, said housing having an interiorly threaded recess at one end to receive a lamp bulb shank and a support positioned adjacent the rear end of the recess, said support being formed to provide a space adjacent the wall of the housing to permit flexing of the housing at that point, a switch member carried by the support and having a portion adapted to be engaged by the center contact of the lamp bulb shank, a switch member carried by the housing and having an extension adapted to be engaged with the switch member carried by the support until disengaged therefrom or to be disengaged from said switch member until re-engaged therewith, all adapted to be done by a moment's flexing of the wall of the housing, a contact member embedded in the housing and having a portion adapted to be engaged by the side contact of the lamp bulb shank, and feed wires connected to the switch member carried by the housing and to the contact member embedded in the housing.

3. A combined switch and socket comprising a housing formed of readily flexible insulating material, said housing having an interiorly threaded recess at one end to receive a lamp bulb shank and a support positioned adjacent the inner end of the recess, said support being formed to provide a space adjacent the wall of the housing to permit flexing of the housing at that point, a switch member carried by the support and having a portion adapted to be engaged by the center contact member of the lamp bulb shank, a switch member carried by the housing and having an extension adapted to be engaged with or disengaged from the switch member carried by the support as the wall of the housing is flexed, a contact member embedded in the housing and having a threaded portion coinciding with the threads of the recess in the housing and adapted to be engaged by the side contact member of the lamp bulb shank, and feed wires connected to the switch member carried by the housing and the contact member embedded in the housing.

4. An electric switch, comprising a body portion of readily flexible insulating material, including an interior block and an exterior housing for completely enclosing coacting switch elements, the block and housing being formed for the accommodation of such switch elements, switch elements confined within the housing and mounted on the body portion, said elements having two normal rest positions, one in which said elements are in electrical contact and the other in which said elements are out of electrical contact, circuit terminals at one end of said housing and leading thereinto for cooperation with said elements in completing a circuit, and a part of said housing upon flexure cooperating with said elements to move said elements from either of said rest positions to the other.

CHARLES A. ADAMS.