

**(12) STANDARD PATENT**  
**(19) AUSTRALIAN PATENT OFFICE**

(11) Application No. **AU 2007288600 B2**

(54) Title  
**A method of performing handover and controlling thereof in a mobile communication system**

(51) International Patent Classification(s)  
**H04W 36/08** (2009.01)      **H04W 76/04** (2009.01)

(21) Application No: **2007288600**      (22) Date of Filing: **2007.08.22**

(87) WIPO No: **WO08/023927**

(30) Priority Data

(31) Number	(32) Date	(33) Country
<b>60/915,417</b>	<b>2007.05.01</b>	<b>US</b>
<b>60/915,666</b>	<b>2007.05.02</b>	<b>US</b>
<b>10-2007-0081356</b>	<b>2007.08.13</b>	<b>KR</b>
<b>60/944,785</b>	<b>2007.06.18</b>	<b>US</b>
<b>60/823,247</b>	<b>2006.08.22</b>	<b>US</b>
<b>60/863,545</b>	<b>2006.10.30</b>	<b>US</b>
<b>60/915,042</b>	<b>2007.04.30</b>	<b>US</b>

(43) Publication Date: **2008.02.28**

(44) Accepted Journal Date: **2010.09.16**

(71) Applicant(s)  
**LG Electronics Inc.**

(72) Inventor(s)  
**Chun, Sung Duck;Yi, Seung June;Park, Sung Jun;Lee, Young Dae**

(74) Agent / Attorney  
**Watermark Patent and Trade Marks Attorneys, Level 2 302 Burwood Road, Hawthorn, VIC, 3122**

(56) Related Art  
**EP 1304898 A1**  
**EP 1148753 A2**

(19) World Intellectual Property Organization  
International Bureau



(43) International Publication Date  
28 February 2008 (28.02.2008)

PCT

(10) International Publication Number  
**WO 2008/023927 A2**

- (51) International Patent Classification:  
*H04Q 7/38* (2006.01)
- (21) International Application Number:  
PCT/KR2007/004011
- (22) International Filing Date: 22 August 2007 (22.08.2007)
- (25) Filing Language: Korean
- (26) Publication Language: English
- (30) Priority Data:
 

60/823,247	22 August 2006 (22.08.2006)	US
60/863,545	30 October 2006 (30.10.2006)	US
60/915,042	30 April 2007 (30.04.2007)	US
60/915,417	1 May 2007 (01.05.2007)	US
60/915,666	2 May 2007 (02.05.2007)	US
60/944,785	18 June 2007 (18.06.2007)	US
10-2007-0081356	13 August 2007 (13.08.2007)	KR
- (72) Inventors; and  
(75) Inventors/Applicants (for US only): **CHUN, Sung Duck** [KR/KR]; LG Institute, Hogye 1(il)-dong, Dongan-gu, Anyang-si, Gyeonggi-do, 431-749 (KR). **LEE, Young Dae** [KR/KR]; LG Institute, Hogye 1(il)-dong, Dongan-gu, Anyang-si, Gyeonggi-do, 431-749 (KR). **PARK, Sung Jun** [KR/KR]; LG Institute, Hogye 1(il)-dong, Dongan-gu, Anyang-si, Gyeonggi-do, 431-749 (KR). **YI, Seung June** [KR/KR]; LG Institute, Hogye 1(il)-dong, Dongan-gu, Anyang-si, Gyeonggi-do, 431-749 (KR).
- (74) Agents: **KIM, Yong In** et al.; KBK & Associates, 15th Floor, YoSam-Building, 648-23Yeoksam-dong, Kangnam-gu., Seoul, 138-748 (KR).
- (81) Designated States (unless otherwise indicated, for every kind of national protection available): AE, AG, AL, AM, AT, AU, AZ, BA, BB, BG, BH, BR, BW, BY, BZ, CA, CH, CN, CO, CR, CU, CZ, DE, DK, DM, DO, DZ, EC, EE, EG, ES, FI, GB, GD, GE, GH, GM, GT, HN, HR, HU, ID, IL, IN, IS, JP, KE, KG, KM, KN, KP, KZ, LA, LC, LK, LR, LS, LT, LU, LY, MA, MD, ME, MG, MK, MN, MW, MX,

(71) Applicant (for all designated States except US): **LG ELECTRONICS INC.** [KR/KR]; 20, Yeouido-dong, Yeongdeungpo-gu, Seoul, 150-721 (KR).

[Continued on next page]

(54) Title: A METHOD OF PERFORMING HANDOVER AND CONTROLLING THEREOF IN A MOBILE COMMUNICATION SYSTEM

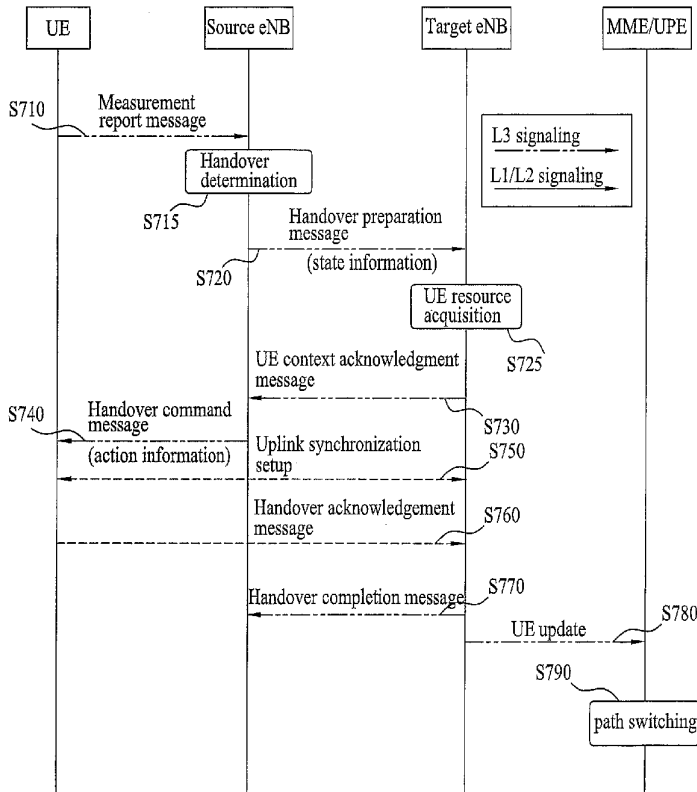

(57) Abstract: A method of controlling handover of a user equipment in a first base station connected with the user equipment in a mobile communication system is disclosed. The first base station transmits state information to a second base station after determining handover to the second base station, wherein the state information includes at least one of information related to a connection setup state between the user equipment and the first base station and information related to a data transmission and reception state. The first base station transmits action information to the user equipment, the action information being related to action to be performed by the user equipment after the user equipment performs handover. The information related to the connection setup state includes information as to whether the user equipment is in an uplink synchronized state or an uplink non-synchronization state before performing handover.

WO 2008/023927 A2



MY, MZ, NA, NG, NI, NO, NZ, OM, PG, PH, PL, PT, RO, RS, RU, SC, SD, SE, SG, SK, SL, SM, SV, SY, TJ, TM, TN, TR, TT, TZ, UA, UG, US, UZ, VC, VN, ZA, ZM, ZW.

European (AT, BE, BG, CH, CY, CZ, DE, DK, EE, ES, FI, FR, GB, GR, HU, IE, IS, IT, LT, LU, LV, MC, MT, NL, PL, PT, RO, SE, SI, SK, TR), OAPI (BF, BJ, CF, CG, CI, CM, GA, GN, GQ, GW, ML, MR, NE, SN, TD, TG).

**(84) Designated States** (*unless otherwise indicated, for every kind of regional protection available*): ARIPO (BW, GH, GM, KE, LS, MW, MZ, NA, SD, SL, SZ, TZ, UG, ZM, ZW), Eurasian (AM, AZ, BY, KG, KZ, MD, RU, TJ, TM),

**Published:**

— *without international search report and to be republished upon receipt of that report*

~~A METHOD OF PERFORMING HANDOVER AND CONTROLLING THEREOF IN~~  
~~A MOBILE COMMUNICATION SYSTEM~~

**[DESCRIPTION]**

5 **TECHNICAL FIELD**

The present invention relates to a mobile communication system, and more particularly, to a method of performing handover and controlling thereof in a mobile communication system.

10 **BACKGROUND ART**

In a mobile communication system, handover means a procedure that, when a user equipment (UE) of which call is connected with a base station is disconnected from a corresponding base station service area and moves to an adjacent base station service area, the user equipment is automatically synchronized with a new communication channel of the adjacent base station and continues to maintain communication. In a broadband wireless communication system which is characterized in data packet communication of large capacity, a handover scheme more efficient than the existing handover scheme is required considering limited communication resources.

FIG. 1 is a flow chart illustrating a handover procedure in a mobile communication system according to the related art.

If a source base station (source eNB) is satisfied with a designated standard or a specific event occurs, a user equipment transmits a measurement report message to the source base station (S110). The source base station means a network node which is connected with the user equipment before handover is performed. The source base station determines handover if it is determined that handover is required referring to the measurement report

message from the user equipment (S115).

The source base station transmits a handover preparation message to a target base station (target eNB), wherein the handover preparation message includes UE context information (S120). The target base station means a base station which controls a new cell to which the user equipment moves through handover. The UE context information includes information related to quality of service (QoS) received from the source base station to the user equipment, a radio bearer type, etc.

The target base station determines whether to allow a request of handover considering its wire and wireless resources. If the target base station determines to allow a request of handover, the target base station acquires resources for connection with the user equipment (S125), and forwards resource setup information of the user equipment to the source base station along with a new temporary identifier (C-RNTI) of the user equipment (S130).

The source base station transmits a handover command to the user equipment (S140), and starts to transmit user data to the target base station. The user equipment performs signaling of a first layer (Layer 1) and a second layer (Layer 2) to reset a wireless environment including timing synchronization with the target base station (S150). The user equipment receives timing information from the target base station and then transmits a handover acknowledgement message to the target base station (S160). The target base station transmits a handover completion message to the source base station to notify success of handover (S170). Afterwards, the source base station releases all resources of the user equipment. The target base station requests a core network (MME/UPE) to update a location of the user equipment (S180). The core network switches path setup of the user equipment to forward user data, which have been conventionally forwarded to the source base station, to the target base station (S190).

However, the aforementioned method of performing handover according to the related art does not consider a connection setup state between the user equipment and the source base station before handover is performed or a data transmission and reception state. For this reason, the user equipment may perform an unnecessary action after  
5 handover completions depending on the connection setup state with the source base station before handover is performed or the data transmission and reception state. In this case, a problem occurs in that the power of the user equipment may be used inefficiently.

Any discussion of documents, devices, acts or knowledge in this specification is included to explain the context of the invention. It should not be taken as an admission  
10 that any of the material formed part of the prior art base or the common general knowledge in the relevant art in Australia on or before the priority date of the claims herein.

#### **DISCLOSURE OF THE INVENTION**

15 It would be desirable to provide a method of performing handover and controlling thereof in a mobile communication system, which substantially alleviates one or more problems due to limitations and disadvantages of the related art.

It would also be desirable to provide a method of performing handover and controlling thereof in a mobile communication system, in which a status of a user  
20 equipment before handover is considered when handover is performed in the mobile communication system.

It would further be desirable to provide a method of performing handover and controlling thereof in a mobile communication system, in which power efficiency of a user equipment is improved when handover is performed in the mobile communication  
25 system.

In accordance with a first aspect of the present invention there is provided a method of controlling handover of a user equipment (UE) in a first base station connected with the user equipment in a mobile communication system, the method including:

30 transmitting a first message to a second base station after determining handover to the second base station, the first message including at least one of information related to a connection setup state between the user equipment and the first base station and information related to a data transmission and reception state;

receiving a second message from the second base station, the second message including information associated with random access; and

transmitting the information associated with random access to the user equipment, wherein the user equipment performs random access to the second base station in accordance with the information associated with random access.

In accordance with another aspect of the present invention there is provided a method of performing handover at a user equipment from a first cell to a second cell in a mobile communication system, the method including:

receiving a message from a base station which controls the first cell or a base station which controls the second cell, the message including information associated with random access to be performed in the second cell by the user equipment to perform handover from the first cell to the second cell; and

performing random access to the second base station according to the information associated with random access in the second cell to perform handover from the first cell to the second cell.

Comprises/comprising and grammatical variations thereof when used in this specification are to be taken to specify the presence of stated features, integers, steps or components or groups thereof, but do not preclude the presence or addition of one or more other features, integers, steps, components or groups thereof.

#### **BRIEF DESCRIPTION OF THE DRAWINGS**

FIG. 1 is a flow chart illustrating a handover procedure in a mobile communication system according to the related art;

FIG. 2 illustrates a network structure of an E-UMTS (Evolved-Universal Mobile Telecommunications System);

FIG. 3 is a schematic diagram illustrating an E-UTRAN (UMTS terrestrial radio access network);

FIG. 4A and 4B illustrate a structure of a radio interface protocol between a user equipment (UE) and E-UTRAN, in which FIG. 4A is an architectural diagram of a control plane protocol and FIG. 4B is an architectural diagram of a user plane protocol;

FIG. 5 illustrates an example of a structure of physical channels used in an E-UMTS system;

FIG. 6 is a flow chart illustrating RRC connection according to the preferred embodiment of the present invention; and

5 FIG. 7 illustrates a handover procedure of a user equipment according to the preferred embodiment of the present invention.

### **BEST MODE FOR CARRYING OUT THE INVENTION**

Hereinafter, structures, operations, and other features of the present invention will be  
10 understood readily by the preferred embodiments of the present invention, examples of which are illustrated in the accompanying drawings. Embodiments described hereinafter are examples in which technical features of the present invention are applied to E-UMTS (Evolved Universal Mobile Telecommunications System).

FIG. 2 illustrates a network structure of an E-UMTS. An E-UMTS is a system  
15 evolving from the conventional WCDMA UMTS and its basic standardization is currently handled by the 3GPP (3<sup>rd</sup> Generation Partnership Project). The E-UMTS can also be called an LTE (Long Term Evolution) system. Release 7 and Release 8 of 3GPP technical specifications (3<sup>rd</sup> Generation Partnership Project; Technical Specification Group Radio Access Network) can be referred to obtain detailed information about the UMTS and E-  
20 UMTS.

Referring to FIG. 2, an E-UTRAN includes base stations (hereinafter, referred to as 'eNode B' or 'eNB'), wherein respective eNBs are connected with each other through X2 interface. Also, each of eNBs is connected with a user equipment (UE) through a radio interface and connected with EPC (Evolved Packet Core) through S1 interface.

25 Layers of a radio interface protocol between a UE and a network can be classified



into a first layer L1, a second layer L2 and a third layer L3 based on three lower layers of OSI (open system interconnection) standard model widely known in communication systems. A physical layer belonging to the first layer L1 provides an information transfer service using a physical channel. A radio resource control (hereinafter, abbreviated as 'RRC') located at the  
5 third layer plays a role in controlling radio resources between the UE and the network. For this, the RRC layer enables RRC messages to be exchanged between the UE and the network. The RRC layer can be distributively located at network nodes including Node B, an AG and the like or at either the Node B or the AG.

FIG. 3 is a schematic view illustrating an E-UTRAN (UMTS terrestrial radio access  
10 network). In FIG. 3, a hatching part represents functional entities of a user plane and a non-hatching part represents functional entities of a control plane.

FIG. 4A and FIG. 4B illustrate a structure of a radio interface protocol between the user equipment (UE) and the E-UTRAN, in which FIG. 4A is a schematic view of a control plane protocol and FIG. 4B is a schematic view of a user plane protocol. Referring to FIG. 4A  
15 and FIG. 4B, a radio interface protocol vertically includes a physical layer, a data link layer, and a network layer and horizontally includes a user plane for data information transfer and a control plane for signaling transfer. The protocol layers in FIG. 4A and FIG. 4B can be classified into L1 (first layer), L2 (second layer), and L3 (third layer) based on three lower layers of the open system interconnection (OSI) standard model widely known in the  
20 communications systems.

The physical layer as the first layer provides information transfer service to an upper layer using physical channels. The physical layer (PHY) is connected to a medium access control (hereinafter, abbreviated as 'MAC') layer above the physical layer via transport channels. Data are transferred between the medium access control layer and the physical  
25 layer via the transport channels. Moreover, data are transferred between different physical

layers, and more particularly, between one physical layer of a transmitting side and the other physical layer of a receiving side via the physical channels. The physical channel of the E-UMTS is modulated according to an orthogonal frequency division multiplexing (OFDM) scheme, and time and frequency are used as radio resources.

5           The medium access control (hereinafter, abbreviated as 'MAC') layer of the second layer provides a service to a radio link control (hereinafter, abbreviated as 'RLC') layer above the MAC layer via logical channels. The RLC layer of the second layer supports reliable data transfer. In order to effectively transmit IP packets (e.g., IPv4 or IPv6) within a radio-communication period having a narrow bandwidth, a PDCP layer of the second layer (L2)  
10 performs header compression to reduce the size of a relatively-large IP packet header containing unnecessary control information.

A radio resource control (hereinafter, abbreviated as 'RRC') layer located on a lowest part of the third layer is defined in the control plane only and is associated with configuration, reconfiguration and release of radio bearers (hereinafter, abbreviated as 'RBs') to be in  
15 charge of controlling the logical, transport and physical channels. In this case, the RB means a service provided by the second layer for the data transfer between the UE and the UTRAN.

As downlink transport channels carrying data from the network to UEs, there are provided a broadcast channel (BCH) carrying system information, a paging channel (PCH)  
20 carrying paging message, and a downlink shared channel (SCH) carrying user traffic or control messages. The traffic or control messages of a downlink multicast or broadcast service can be transmitted via the downlink SCH or an additional downlink multicast channel (MCH). Meanwhile, as uplink transport channels carrying data from UEs to the network, there are provided a random access channel (RACH) carrying an initial control message and  
25 an uplink shared channel (UL-SCH) carrying user traffic or control message.

As logical channels located above the transport channels and mapped with the transport channels, there are provided a broadcast channel (BCCH), a paging control channel (PCCH), a common control channel (CCCH), a multicast control channel (MCCH), and a multicast traffic channel (MTCH).

5 In the E-UMTS system, an OFDM is used on the downlink and a single carrier frequency division multiple access (SC-FDMA) on the uplink. The OFDM scheme using multiple carriers allocates resources by unit of multiple sub-carriers including a group of carriers and utilizes an orthogonal frequency division multiple access (OFDMA) as an access scheme.

10 A physical layer of an OFDM or OFDMA scheme divides active carriers into a plurality of groups and transmits respective groups to different receiving sides. Radio resource allocated to each UE which is defined by a time-frequency region on a two-dimensional sphere comprises continuous sub-carriers. A time-frequency region in the OFDM or OFDMA scheme is a rectangular form sectioned by time and sub-carrier coordinates. In  
15 other words, one time-frequency region could be a rectangular form sectioned by at least one symbol on a time axis and sub-carriers on a frequency axis. Such a time-frequency region can be allocated to an uplink for a specific UE, or an eNB can transmit the time-frequency region to a specific UE in a downlink. In order to define such a time-frequency region on the two-dimensional sphere, the number of OFDM symbols and the number of continuous sub-  
20 carriers starting from a point having an offset from a reference point should be given.

The E-UMTS which is currently being discussed uses 10 ms radio frame comprising 20 sub-frames. Namely, a sub-frame has a length of 0.5 ms. A resource block comprises one sub-frame and twelve sub-carriers, each of which is 15 kHz. One sub-frame comprises a plurality of OFDM symbols and a part (for example, first symbol) of the plurality of OFDM  
25 symbols can be used for transmission of L1/L2 control information.

FIG. 5 is a diagram illustrating a structure of physical channels used in the E-UMTS. In FIG. 5, a sub-frame comprises an L1/L2 control information transmission region (the hatching part) and a data transmission region (the non-hatching part).

Meanwhile, paging means that a network calls one or more user equipments for some purpose. This paging function is to allow the network to find a specific user equipment in view of a basic aspect and to allow the user equipment to be in a sleeping mode if not necessary, thereby saving the power of the user equipment. In other words, the user equipment is in a sleeping mode at ordinary times and then wakes up, if paging is sent from the network, to take action required by the network.

To identify paging, the user equipment in a sleeping mode periodically wakes up to identify the presence of paging information sent to the user equipment. Periodical waking up of the user equipment means discontinuous reception (hereinafter, referred to as DRX). The E-UMTS (Universal Mobile Telecommunications system) which is an European IMT-2000 system uses the DRX as a method of receiving paging information of the user equipment. Structural elements for setting call between the user equipment and the system have been described as above.

FIG. 6 illustrates transmission of messages exchanged between a user equipment (UE) and a radio network controller (RNC) for RRC connection in the E-UTRAN system and initial direct transfer (IDT) message transmission for signal connection. In this case, the RNC is an apparatus which exists within a radio network subsystem (RNS), and serves to control integrity and use of radio resources. The RNS means an access part only in the E-UTRAN which provides allocation and release of radio resources for call setup means between the entire communication system or the user equipment and E-UTRAN.

To set up call with the UMTS system, the user equipment should perform RRC connection with the E-UTRAN, and perform signaling connection with CN. To this end, RRC

state of the user equipment and RRC connection method will be described. The RRC state means whether RRC of the user equipment is logically connected with RRC of the E-UTRAN. The RRC state is called RRC connected state if the RRC of the user equipment is logically connected with the RRC of the E-UTRAN. On the other hand, the RRC state is called RRC idle state if not so. The E-UTRAN can identify the presence of the user equipment of the RRC connection state in a cell unit due to the presence of the RRC connection. Accordingly, the E-UTRAN can effectively control the user equipment. By contrast, the E-UTRAN cannot identify the user equipment of the RRC idle state, and a core network manages the user equipment of the idle state in a unit of a tracking area which is a local unit greater than the cell. In other words, in case of the user equipment of the RRC idle state, its presence is identified in a great local unit. The user equipment should move to the RRC connection state to obtain a typical mobile communication service such as voice or data. Hereinafter, the procedure of moving to the RRC connection state will be described in detail.

When a user first turns on the power of the user equipment, the user equipment searches a proper cell and then stays in the corresponding cell in the RRC idle state. The user equipment which stays in the RRC idle state performs RRC connection with the RRC of the E-UTRAN through an RRC connection procedure if the RRC connection is required, and transits to the RRC connection state. The user equipment which is in the RRC idle state needs the RRC connection in case of various examples. For example, the user equipment which is in the RRC idle state needs the RRC connection if uplink data transmission is needed due to trying calling of the user or if a response message transmission to a paging message received from the E-UTRAN is needed. The user equipment exchanges control information dedicated for the user equipment with the UTRAN or the CN through RRC connection and signaling connection. As shown in FIG. 6, as a first procedure for RRC connection, the user equipment transmits an RRC connection request message to the RNC.

Also, the RNC transmits an RRC connection setup message to the user equipment in response to the RRC connection request message. The user equipment transmits an RRC connection setup complete message to the RNC. If the aforementioned procedure successfully ends, the user equipment performs the RRC connection with the RNC. After the RRC connection is generated, the user equipment transmits IDT message to start the procedure of performing signaling connection.

FIG. 7 illustrates a handover procedure of the user equipment according to the preferred embodiment of the present invention.

Referring to FIG. 7, if a certain standard is satisfied or a specific event occurs, the user equipment transmits a measurement report message to a source base station (S710). The source base station serves as a radio communication terminal with the user equipment and performs an RRC management function. The measurement report message includes information related to signal intensity from neighboring cells measured by the user equipment.

In the handover procedure of the user equipment according to the preferred embodiment of the present invention, during transmission of the measurement report message, the user equipment which is in a non-synchronized state can transmit a measurement result of cells depending on a size allowed by available radio resources. For example, if radio resources allocated from the source base station to the user equipment are 100 bits and 30 bits are required for information of one cell included in the measurement report message, the user equipment transmits the measurement result of three cells. Also, to increase a handover success rate of the user equipment, the user equipment which is in the non-synchronized state can report the measurement result of the cell having the largest signal among the cells measured by the user equipment when transmitting the measurement report message.

To transmit the measurement report message from the user equipment to the source base station, the user equipment should be synchronized with the source base station. If the

user equipment is not synchronized with the source base station, the user equipment synchronizes with the source base station through a random access channel (RACH) in the E-UTRAN system. Hereinafter, the RACH will be described.

The RACH is used to transmit short data to an uplink, and some RRC messages such as RRC connection request message, cell update message, and URA update message can be transmitted through the RACH.

Furthermore, a common control channel (CCCH), a dedicated control channel (DCCH), or a dedicated traffic channel (DTCH), which is one of logical channels, can be mapped with the RACH which is one of transport channels. Furthermore, the RACH which is one of transport channels is again mapped with a physical random access channel (PRACH) which is one of physical channels. The PRACH which is an uplink physical channel is divided into a preamble part and a message part. The preamble part performs a power ramping function controlling a proper transmission power used for message transmission and a function of preventing collision among several user equipments. The preamble part may include uplink message information or channel measurement information to allow the source base station to perform resource allocation for uplink message transmission. The message part serves to transmit MAC PDU forwarded from MAC to a physical channel. A detailed RACH procedure will be described below.

MAC layer included in the user equipment commands a physical layer of the user equipment to perform PRACH transmission. Afterwards, the physical layer of the user equipment selects one access slot and one signature, and transmits PRACH preamble to the uplink depending on the selected result.

If the user equipment transmits the preamble, the base station transmits a response signal through an acquisition indicator channel (AICH) which is a downlink physical channel. The AICH transmitted in response to the preamble includes information of consent or

rejection of the preamble transmission and signature transmitted from the user equipment, a temporary cell radio network temporary identifier (C-RNTI) allocated to the user equipment, and control information related to transmission of the RRC connection request message. The control information related to transmission of the RRC connection request message includes  
5 radio resource allocation information, message size, radio parameters (modulation and coding information, Hybrid ARQ information, etc.) for transmission of the RRC connection request message, and timing information.

Signaling information for receiving the random access response message is notified through L1/L2 control channel. The signaling information includes a random access radio  
10 network temporary identifier (RA-RNTI) which indicates transmission of the random access response message and transmission parameters related to transmission of the random access response message.

The source base station determines handover referring to the measurement report message from the user equipment if it is determined that handover is required (S715). The  
15 user equipment may determine handover and report it to the source base station depending on the system. If the source base station determines handover, the source base station transmits a handover preparation message to a target base station (target eNB) (S720). The handover preparation message includes UE context information and state information (S720). The state information includes at least one of information related to a connection setup state between  
20 the user equipment and the source base station and information related to a data transmission and reception state. The state information may be configured to be included in the UE context information. Alternatively, the state information may be forwarded to the target base station in a separate message type without being included in the handover message.

The information related to the connection setup state includes information indicating  
25 whether the user equipment is uplink-synchronized with the source base station. The uplink



synchronized state will be described below.

As described above, OFDMA scheme is used for a physical channel in the E-UTRAN system. The OFDMA scheme divides a frequency band into bands of a certain size, and allocates each band to several user equipments. In this case, data reception may not be performed as data transmitted from each frequency band interfere with data transmitted from the other band. To avoid this, synchronization in transmission time between the respective user equipments is important in the OFDM. In other words, a user equipment 1 and a user equipment 2 are scheduled to transmit data in a specific time interval, an arrival time of transmission of the user equipment 1 to the base station should be coincident with an arrival time of transmission of the user equipment 2 to the base station. Data of the user equipments 1 and 2 cannot be recovered in the base station if there is a little difference between the arrival time of transmission of the user equipment 1 and the arrival time of transmission of the user equipment 2.

Accordingly, the E-UTRAN system is required to essentially perform synchronization in uplink channel transmission of each user equipment. To this end, several methods are used. One of them is to use the RACH. The user equipment which does not maintain synchronization in uplink channel with the base station transmits a bit stream, which is previously determined, i.e., signature, to the RACH, and the base station detects the signature. The base station calculates how transmission of the user equipment should be slowly or quickly performed for synchronization in uplink channel, based on the detected signal. The base station reports the calculated result to the user equipment. The user equipment controls its transmission time based on the calculated value and then performs uplink synchronization.

The information related to the data transmission and reception state of the user equipment includes active state or activity level information related to the data transmission

and reception state of the user equipment. For example, the information related to the data transmission and reception state of the user equipment may include level information indicating whether data transmission and reception of the user equipment has not been performed for what time period or indicating a level of data transmission and reception activity of the user equipment. Also, the information related to the data transmission and reception state may include a current DRX level. Also, the transmission activity level information may include information as to how many times the user equipment performs transmission and whether data transmission and reception has not been performed for what time period, or information of the last transmission and reception time.

10           The data transmission and reception state information may includes a maximum value, a minimum value and an average value of a data transmission rate between the source base station and the user equipment, and a maximum value, a minimum value and an average value of a data transmission interval between the source base station and the user equipment. Also, the data transmission and reception state information may include a maximum value, a  
15           minimum value or an average value of a duty cycle or a duty factor in data transmission between the source base station and the user equipment. These values notify how many times data transmission and reception is performed for a certain time period.

          The information related to the connection setup state includes information required to manage either the RRC connection state between the source base station and the user  
20           equipment or a synchronized state in an uplink direction of the user equipment. In other words, the information related to the connection setup state is required to control the RRC state or the synchronized state of the user equipment. Also, the information related to the connection setup state may include information indicating when transition of the RRC connection state between the target base station and the user equipment or transition of the  
25           synchronized state in an uplink direction of the user equipment should occur or preferably

occurs as the case may be.

The data transmission and reception state information may include information as to how long time the source base station has not transmitted data to the user equipment or how long time the source base station has not received data from the user equipment. Also, the data transmission and reception state information may include information as to when the last data transmission to the user equipment or the last data reception from the user equipment has occurred.

The data transmission and reception state information may further include information of discontinuous reception parameter (DRX parameter) setup value set in the user equipment, a DRX parameter setup value used finally by the user equipment, and a plurality of DRX setup values set in the user equipment. The DRX setup value includes a period which the user equipment periodically receives a downlink channel, a DRX level of the user equipment, or a time which the user equipment stays in a DRX level.

Referring to FIG. 6 again, the target base station which has received the handover preparation message from the source base station determines whether to allow a handover request considering its wire and wireless resources. If it is possible to allow a handover request, the target base station acquires resources for connection with the user equipment (S725). The source base station forwards a UE context acknowledgement message, which includes resource setup information of the user equipment and information to be used by the user equipment in a new cell of the target base station, to the source base station along with a new C-RNTI (S730).

The UE context acknowledgement message may include action information related to action to be performed in a new cell after the user equipment completes handover. For example, the UE context acknowledgement message may include information as to whether uplink synchronization should be performed in a new cell after the user equipment completes

handover. In other words, if the user equipment is not uplink-synchronized with the source base station before performing handover, uplink synchronization procedure is not needed in a new cell of the target base station after the user equipment completes handover. Accordingly, the target base station notifies the source base station that the uplink synchronization procedure is not needed after the user equipment completes handover. Since the uplink synchronization procedure is performed through the RACH, the UE context acknowledgement message may include information as to whether the RACH procedure should be performed in a new cell after the user equipment completes handover. Also, if the user equipment is synchronized with the source base station within a synchronization timer period, and if the user equipment has data to be transmitted to the target base station, since the data should be transmitted through the RACH procedure, the UE context acknowledgement message serves as information of the RACH procedure.

The UE context acknowledgement message may include information as to whether the user equipment should transmit the handover acknowledgement message to the target base station after completing handover. The user equipment should transmit the handover acknowledgement message to the source base station or the target base station if it performs handover. The user equipment can determine whether to transmit the handover acknowledgement message to which side depending on the information as to whether the user equipment should transmit the handover acknowledgement message. The UE context acknowledgement message may further include a DRX parameter setup value to be applied to a new cell by the user equipment. Also, the UE context acknowledgement message may further include a measurement related parameter to be performed in a new cell by the user equipment. In other words, since the user equipment is in an uplink non-synchronized state before performing handover, the user equipment can receive the measurement related parameter, which has received through the existing synchronization procedure, through the

UE context acknowledgement message, if the user equipment is not synchronized with the target base station.

The source base station transmits a handover command message to the user equipment, wherein the handover command message includes at least a part of the UE context acknowledgement message (S740), and starts to transmit user data to the target base station. The handover command message includes action information related to action to be performed in a new cell by the user equipment after the user equipment completes handover. Whether the user equipment should perform specific action in a new cell after completing handover can be determined by the source base station or the target base station.

10 The user equipment performs action according to action information included in the handover command message in the new cell after completing handover. For example, if the action information commands that the user equipment should transmit or should not transmit the handover acknowledgement message to the target base station after completing handover, the user equipment moves to the new cell and transmits or does not transmit the handover acknowledgement message to the target base station depending on the command.

For another example, if the action information commands that the user equipment should perform or should not perform uplink synchronization procedure (or RACH procedure) after completing handover, the user equipment moves to the new cell and performs or does not perform the uplink synchronization procedure (or RACH procedure) depending on the command.

The above procedure suggested in the preferred embodiment of the present invention includes transmitting the handover acknowledgement message from the user equipment to the current cell before moving to the new cell in accordance with a handover command. Alternatively, the user equipment may not transmit the handover acknowledgement message to the current cell before moving to the new cell in accordance with the handover command.

If the uplink synchronization procedure is performed in the new cell after the user equipment completes handover, the user equipment performs signaling of a first layer (Layer 1) and a second layer (Layer 2) to reset a wireless environment including timing synchronization with the target base station (S750). If the action information commands that the user equipment should transmit the handover acknowledgement message from the new cell to the target base station, the user equipment transmits the handover acknowledgement message to the target base station after completing handover (S760). The target base station requests a core network (MME/UPE) to update a location of the user equipment (S780).

Afterwards, the core network switches a path setup of the user equipment to forward user data, which have been conventionally forwarded to the source base station, to the target base station (S790).

However, if the action information commands that the user equipment should not perform the uplink synchronization procedure in the new cell after completing handover, the user equipment does not need to perform the uplink synchronization procedure in the new cell (failure in S750). Also, if the action information commands that the user equipment should not transmit the handover acknowledgement message to the target base station after performing handover, the user equipment does not need to transmit the handover acknowledgement message to the target base station (failure in S760).

The target base station transmits a handover completion message to the source base station to notify success of handover (S770). Afterwards, the source base station releases all resources of the user equipment. The target base station requests the core network (MME/UPE) to update the location of the user equipment (S780). Afterwards, the core network switches path setup of the user equipment and transmits user data, which have been conventionally transmitted to the source base station, to the target base station (S790).

In the handover procedure according to the preferred embodiment of the present

invention, if the user equipment moves to the new cell of the target base station, the user equipment can continue to use parameters used in the source base station. Examples of the parameters include a DRX setup value, a synchronization timer setup value, a non-synchronized state transition timer setup value, a periodic cell update timer setup value, and a  
5 periodic measurement report timer setup value.

The DRX setup value is used to allow the user equipment to perform DRX. The synchronization timer setup value is information of a timer value required to allow the user equipment to periodically perform a synchronization procedure. The non-synchronized state transition timer setup value is a value related to setting as to whether the user equipment is  
10 transitioned to a non-synchronized state depending on how long time passes after performing the synchronization procedure. The periodic cell update timer setup value is a setup value as to whether the user equipment should perform cell update at what time interval. The periodic measurement report timer setup value is a setup value as to whether the user equipment should transmit the measurement report message at what time interval.

15 In other words, if the user equipment has a DRX period of 1 second in the existing cell and sends 0.5 second of the DRX period directly before handover, the user equipment performs DRX for the other value of DRX, i.e., 0.5 second in a new cell.

In one preferred embodiment of the present invention, the source base station transmits the state information of the user equipment to the target base station, and the target  
20 base station determines action to be performed in a new cell by the user equipment after the user equipment completes handover, to forward the determined action to the user equipment through the source base station. In other words, the target base station determines whether to perform the synchronization procedure in a new cell, and the source base station serves to simply relay related information between the user equipment and the target base station.

25 In another preferred embodiment of the present invention, the source base station

determines action to be performed in a new cell by the user equipment after the user equipment performs handover, and forwards the determined action to the user equipment. For example, the source base station determines whether to perform the uplink synchronization procedure (RACH procedure) and transmit the handover acknowledgement message, and  
5 transmits the determined action through a handover command.

It will be apparent to those skilled in the art that the present invention can be embodied in other specific forms without departing from the spirit and essential characteristics of the invention. Thus, the above embodiments are to be considered in all respects as illustrative and not restrictive. The scope of the invention should be determined  
10 by reasonable interpretation of the appended claims and all change which comes within the equivalent scope of the invention are included in the scope of the invention.

#### INDUSTRIAL APPLICABILITY

The present invention is applicable to such a wireless communication system as a  
15 wireless internet system, a mobile communication system and the like.



THE CLAIMS DEFINING THE INVENTION ARE AS FOLLOWS:

1. A method of controlling handover of a user equipment (UE) in a first base station connected with the user equipment in a mobile communication system, the method including:

5 transmitting a first message to a second base station after determining handover to the second base station, the first message including at least one of information related to a connection setup state between the user equipment and the first base station and information related to a data transmission and reception state;

10 receiving a second message from the second base station, the second message including information associated with random access; and

transmitting the information associated with random access to the user equipment, wherein the user equipment performs random access to the second base station in accordance with the information associated with random access.

15 2. The method of claim 1, wherein the information related to the connection setup state includes information related to an uplink synchronized state of the user equipment.

3. The method of claim 1, wherein the information related to the data transmission and reception state includes activity level information related to a data transmission and reception state of the user equipment.

20 4. A method of performing handover at a user equipment from a first cell to a second cell in a mobile communication system, the method including:

receiving a message from a base station which controls the first cell or a base station which controls the second cell, the message including information associated with random access to be performed in the second cell by the user equipment to perform handover from the first cell to the second cell; and

25 performing random access to the second base station according to the information associated with random access in the second cell to perform handover from the first cell to the second cell.

5. The method of claim 4, further including transmitting a handover confirm message to the second base station to confirm completion of handover.

6. A user equipment adapted to carry out a method in accordance with claim 4 or 5.
7. The method of claim 1, wherein the information related to a data transmission and reception state includes information about duration while the user equipment has not transmitted or received data.
- 5 8. A method substantially as herein before described with reference to Figures 6 and 7 of the accompanying drawings.

**LG ELECTRONICS INC**

**WATERMARK PATENT & TRADE MARK ATTORNEYS**

P31572AU00

FIG. 1

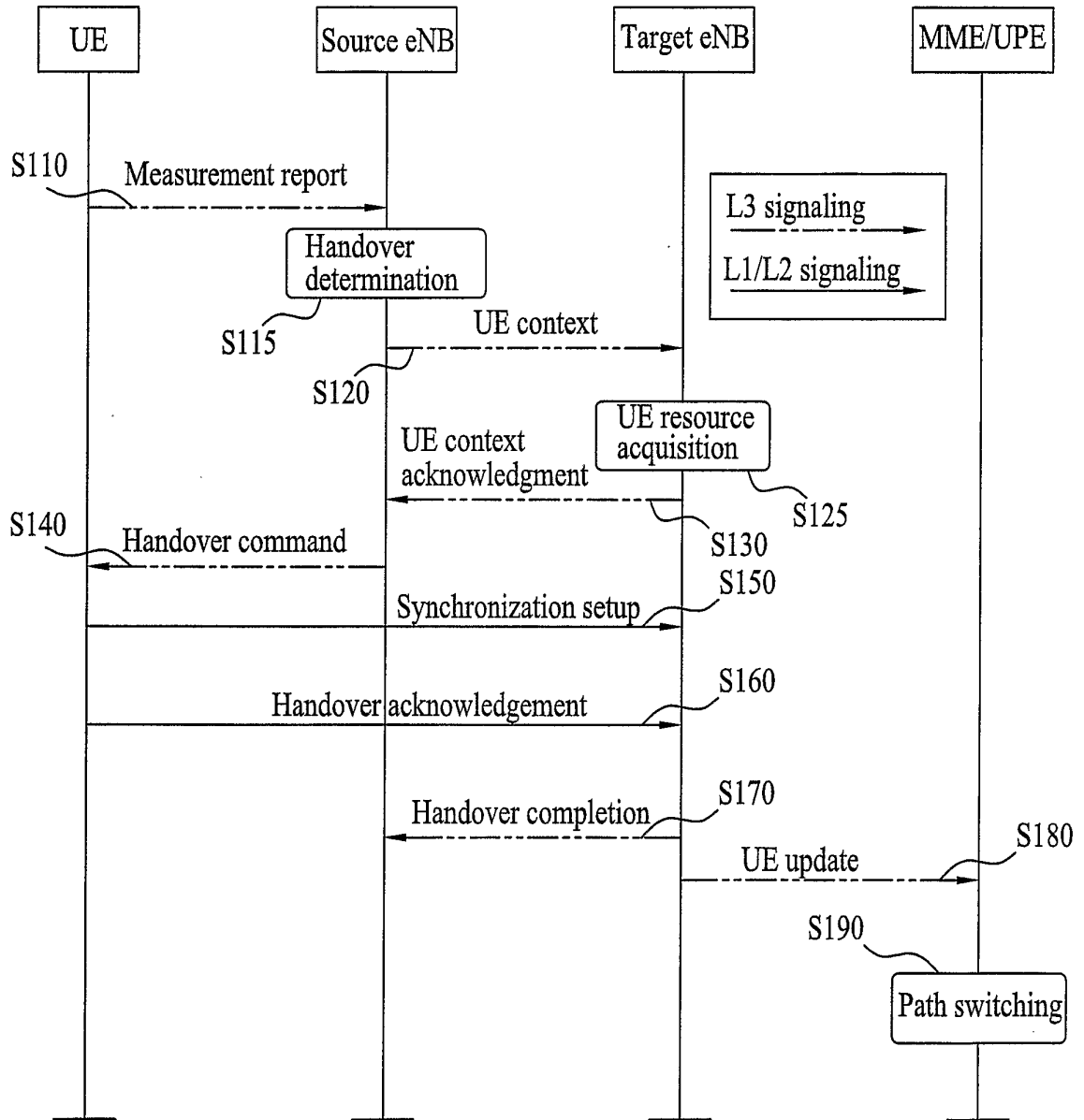

FIG. 2

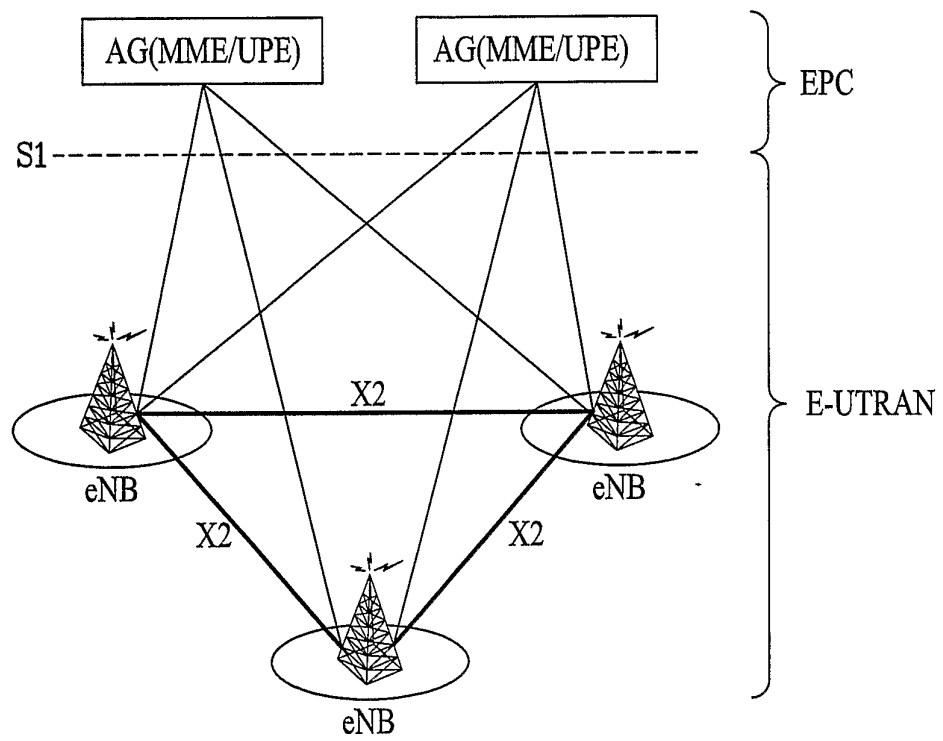

FIG. 3

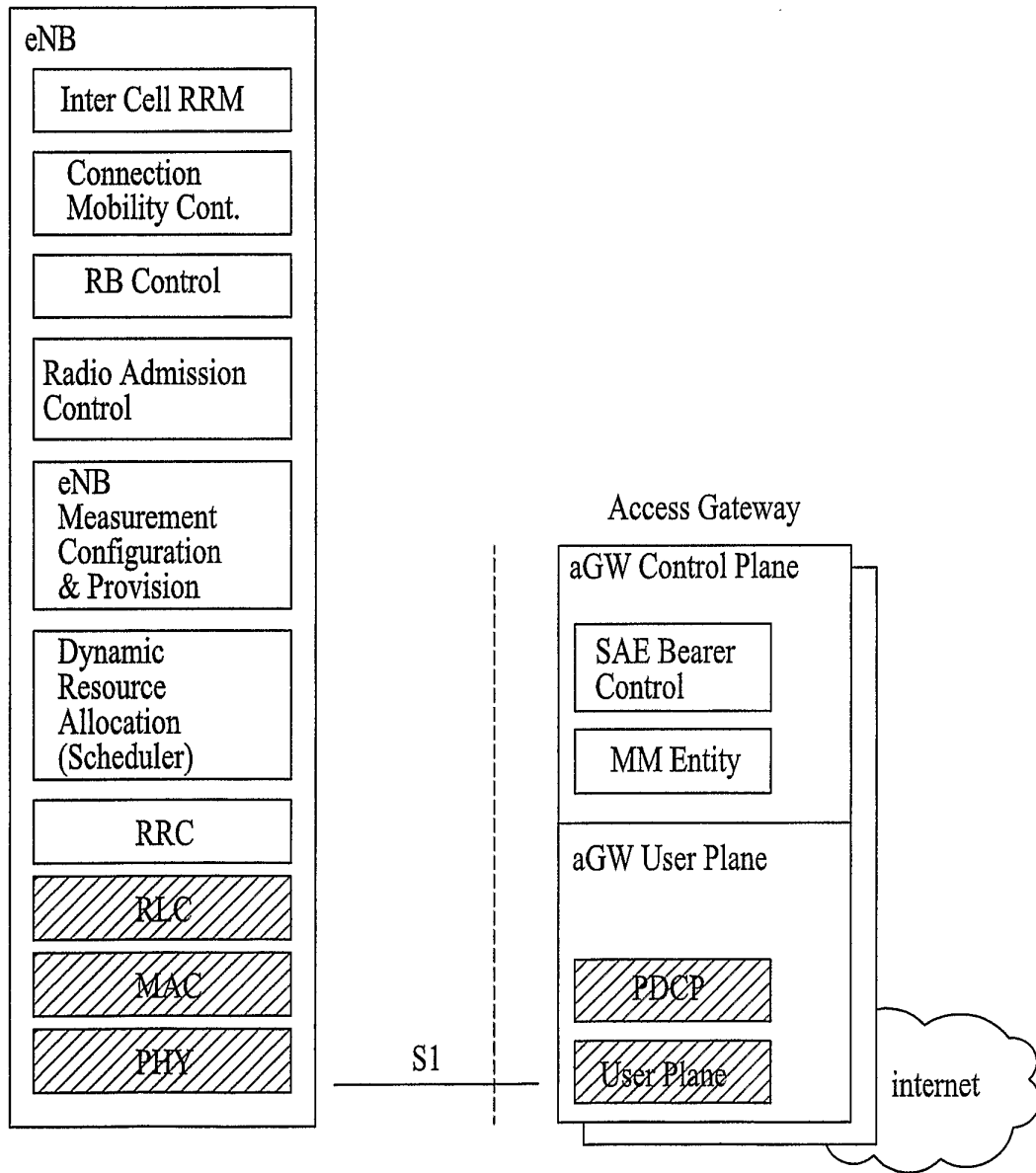

FIG. 4A

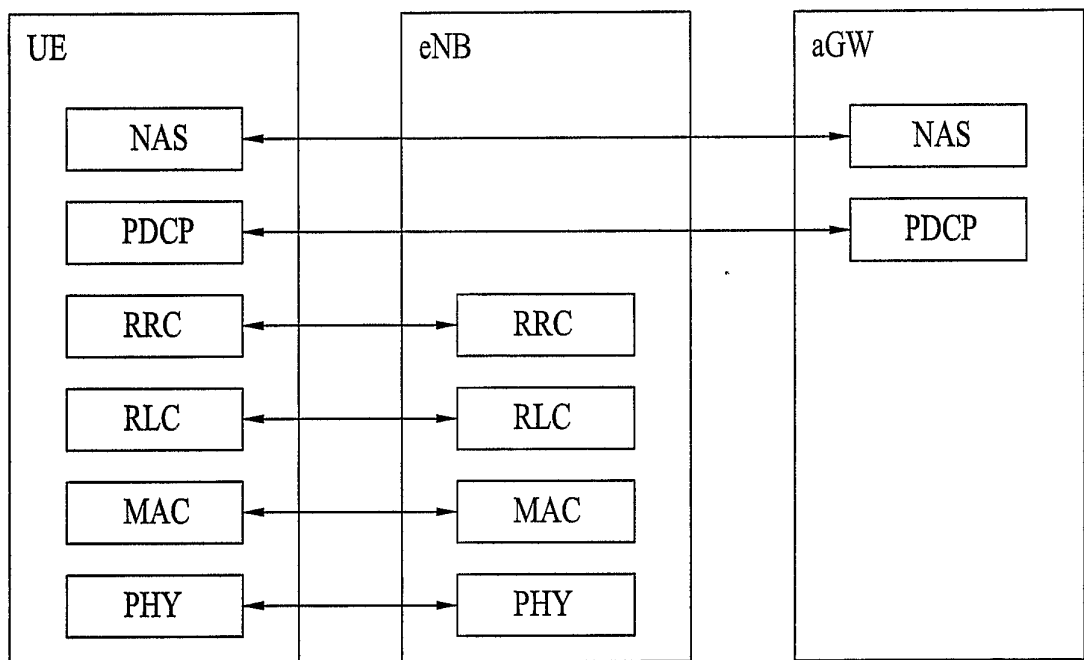

FIG. 4B

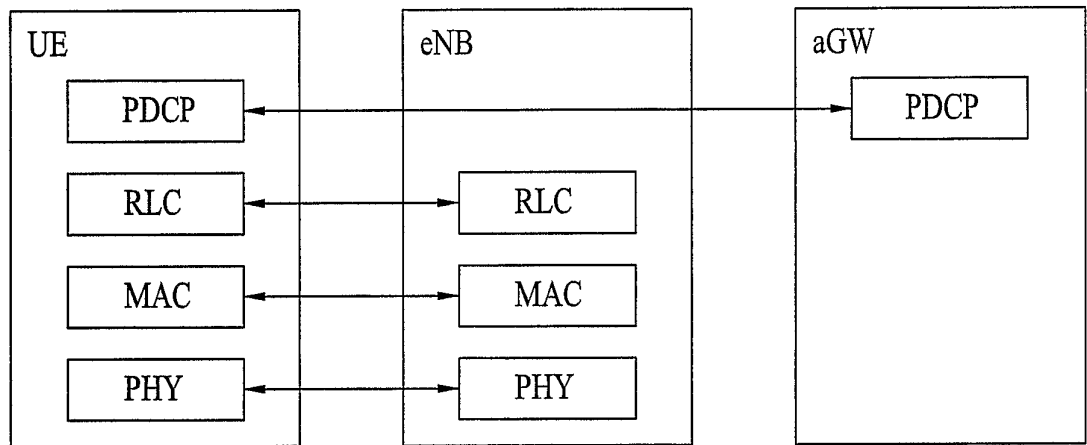
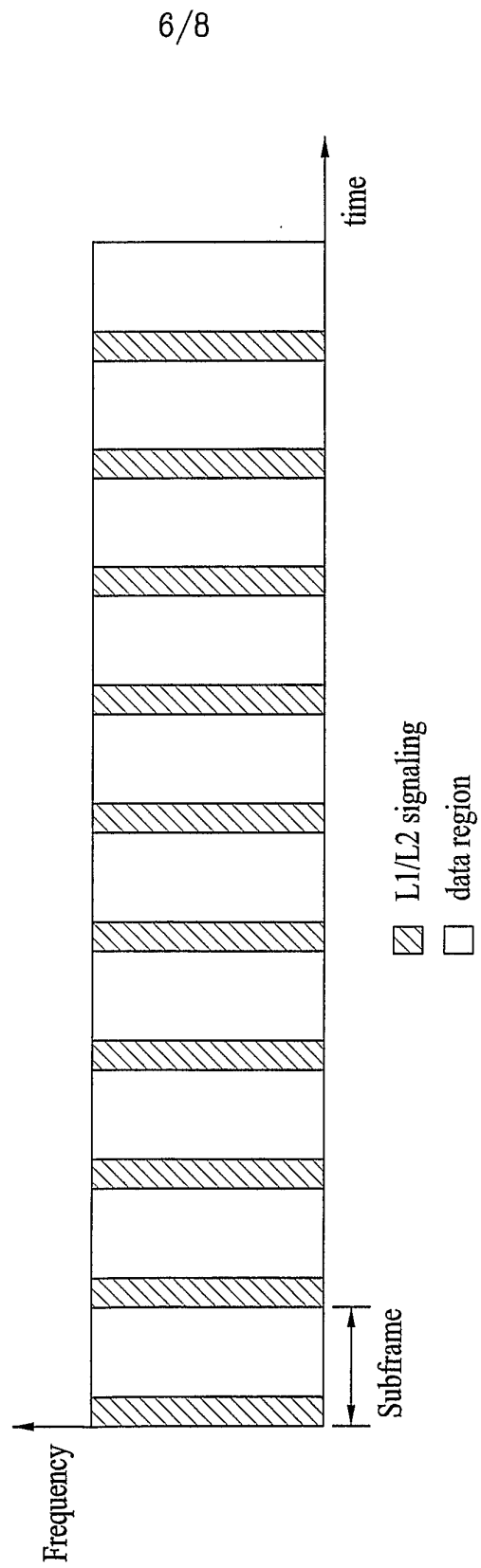

FIG. 5





7/8

FIG. 6

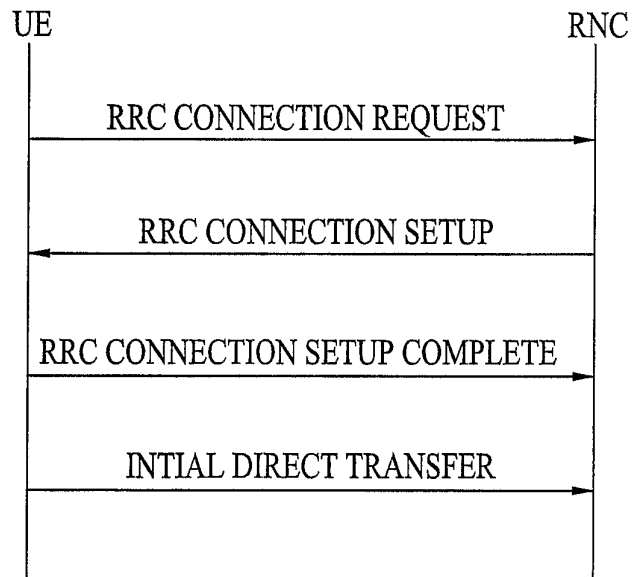

8/8  
FIG. 7

