

- [54] **INFLATABLE STRUCTURAL COMPONENT**
- [75] Inventor: **Dennis Gunst**, Los Angeles, Calif.
- [73] Assignee: **Morris Schwartzman**, Los Angeles, Calif. ; a part interest
- [22] Filed: **July 15, 1974**
- [21] Appl. No.: **488,471**

3,676,276	7/1972	Hirshen et al.	161/117
3,678,553	7/1972	Hermelen	29/91.1
3,705,429	12/1972	Nail	5/349

Primary Examiner—Paul R. Gilliam
Assistant Examiner—Andrew M. Calvert
Attorney, Agent, or Firm—Saul Epstein

Related U.S. Application Data

- [63] Continuation-in-part of Ser. No. 349,404, April 9, 1973, abandoned.
- [52] U.S. Cl. 5/350; 297/456
- [51] Int. Cl.² A47C 27/08
- [58] Field of Search..... 5/82, 341, 349, 348 R, 5/350; 297/456, DIG. 3

References Cited

UNITED STATES PATENTS

2,450,699	10/1948	Veach.....	5/350
3,178,732	4/1965	Stibitz.....	5/81

[57] **ABSTRACT**

An inflatable structural component including an inflatable envelope of tubular configuration and a tensile member extending longitudinally through the envelope. The tensile member may assume the form of a cord, wire, spring, band, etc., or may even constitute an extension of the inflatable envelope. The inflatable envelope can be bent into diverse shapes and can thus be utilized as a structural component for furniture, beds, rafts, couches, tents, abstract sculpture and the like.

12 Claims, 19 Drawing Figures

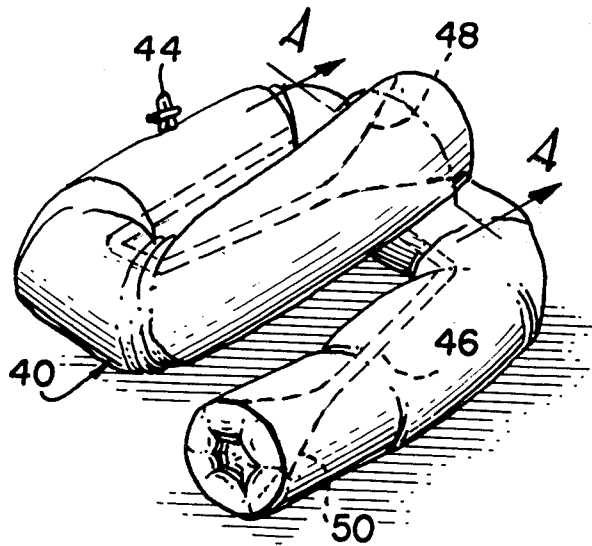

FIG. 2

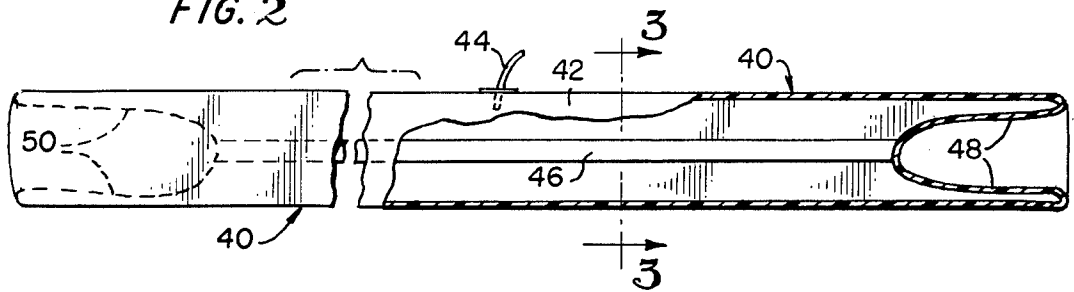

FIG. 3

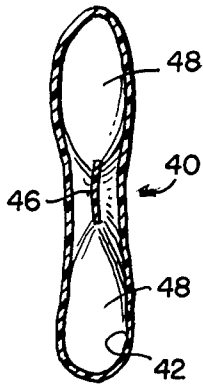

FIG. 4

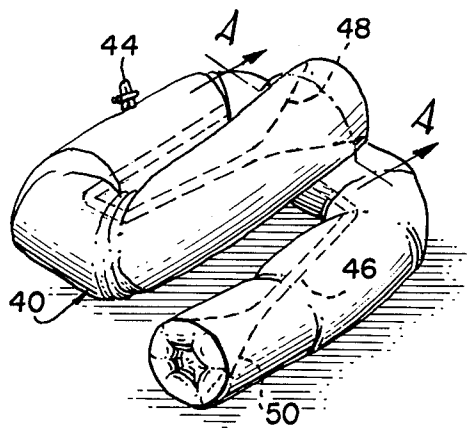

FIG. 4

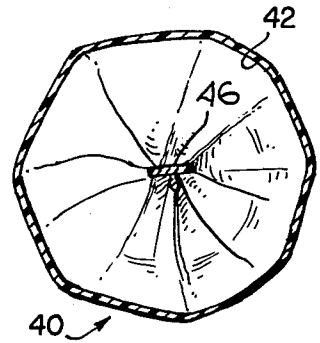

FIG. 5

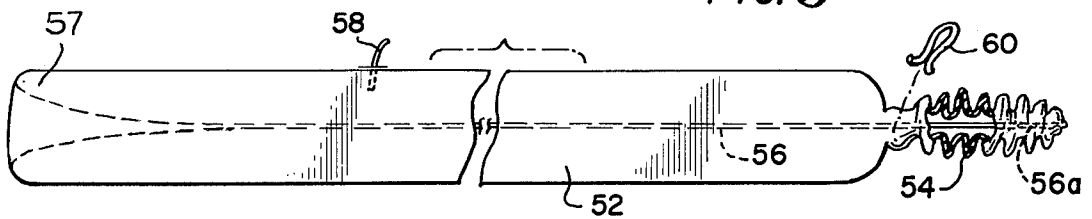

FIG. 6

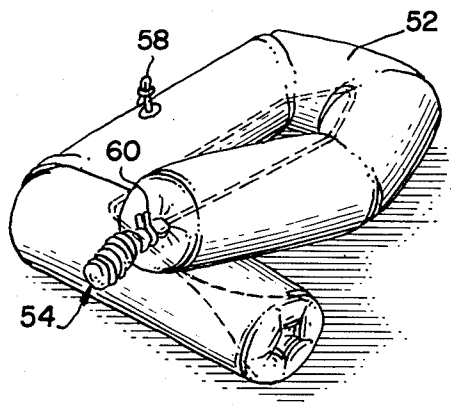

Fig. 7

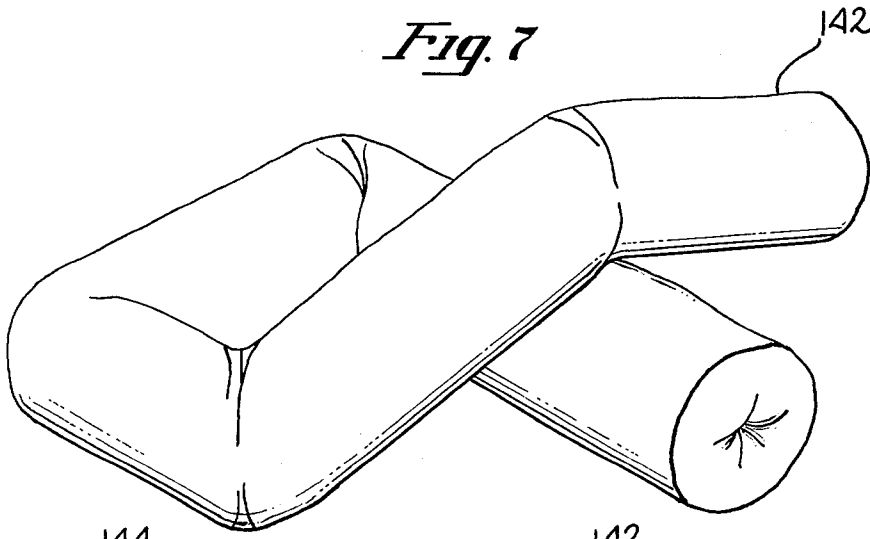

Fig. 8

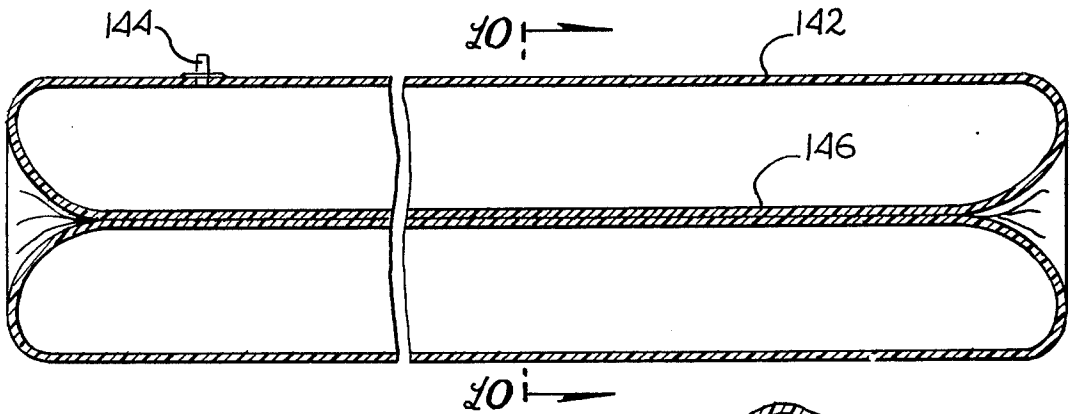
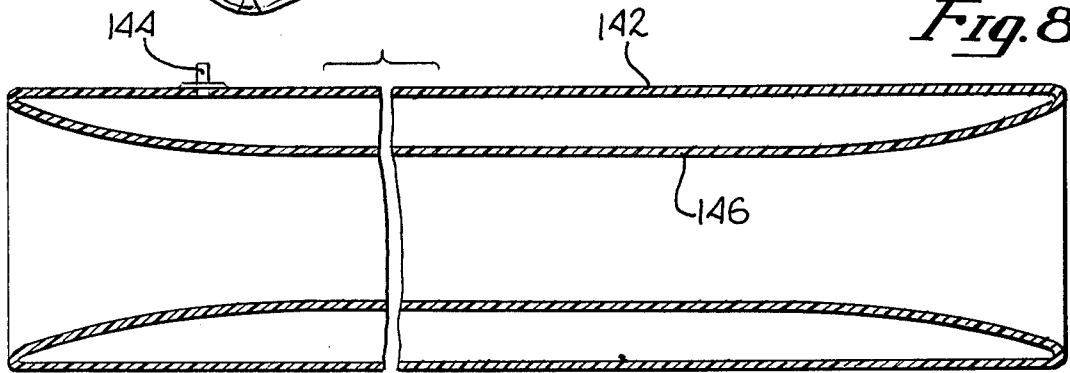

Fig. 9

Fig. 10

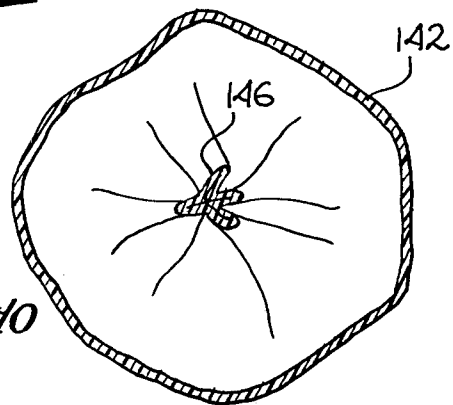

FIG. 11.

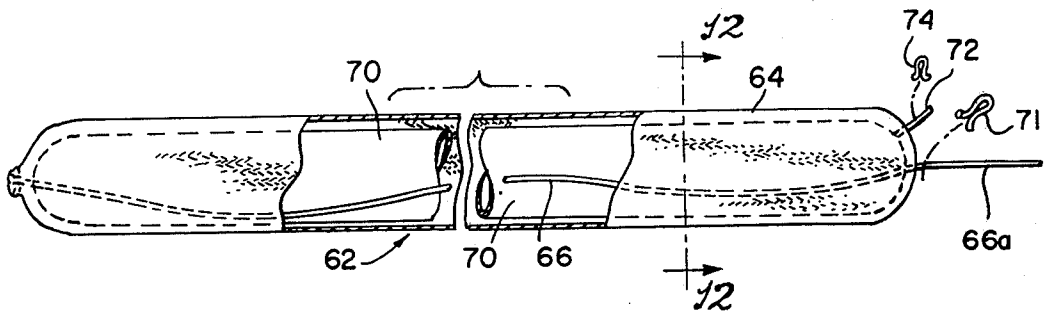

FIG. 12.

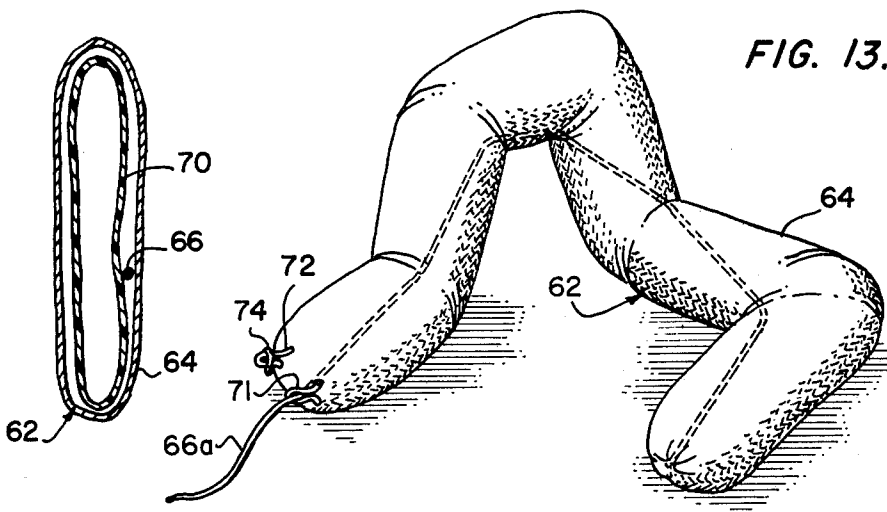

FIG. 13.

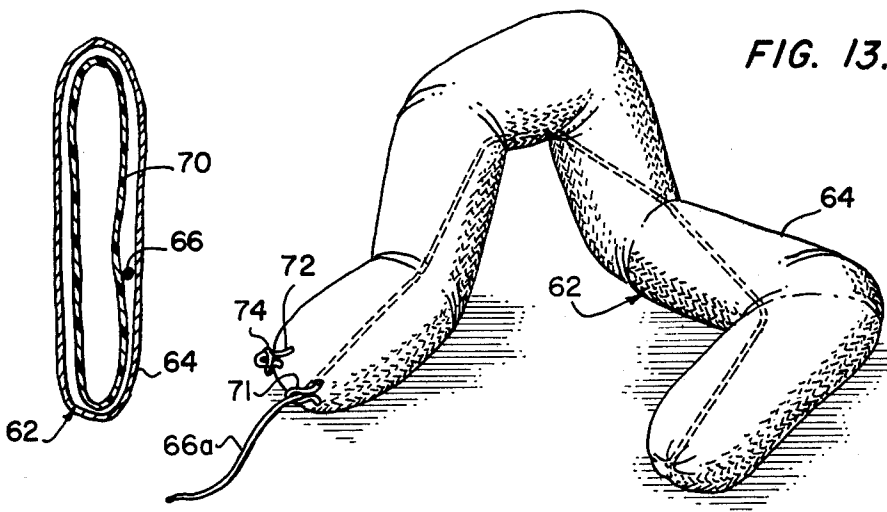

FIG. 14.

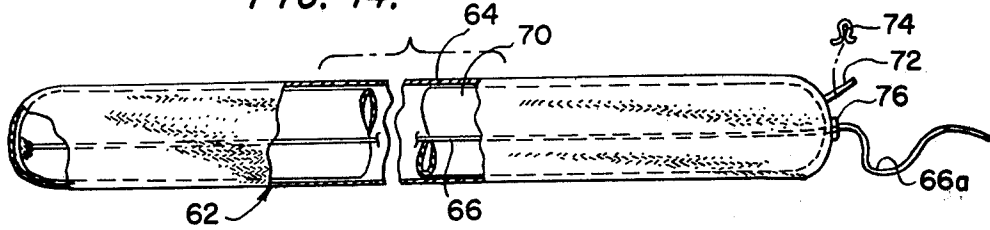

FIG. 15.

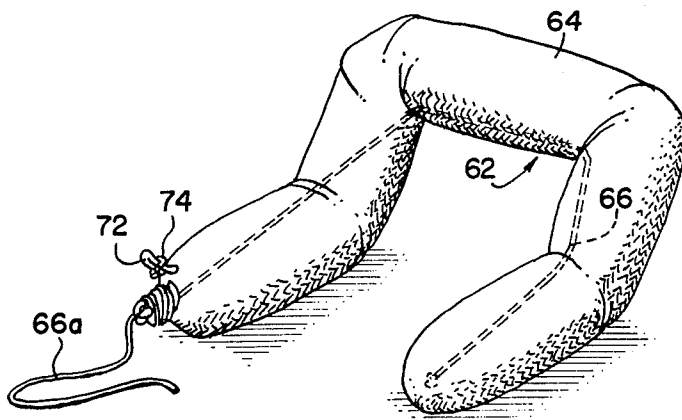

FIG. 16

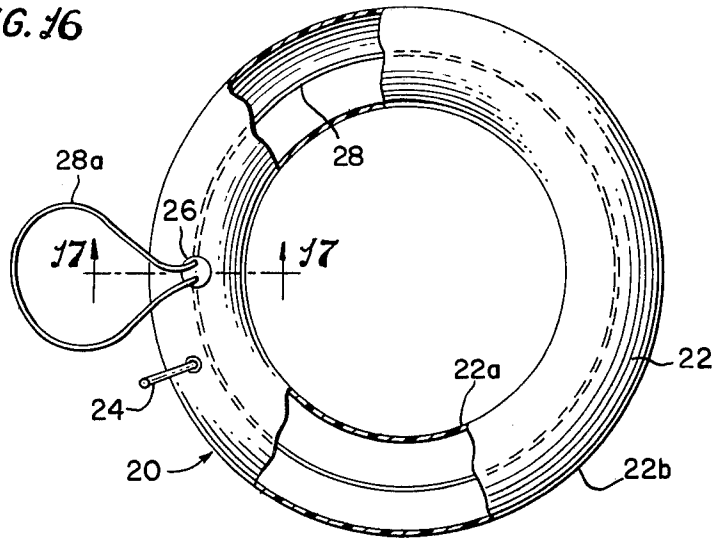

FIG. 17

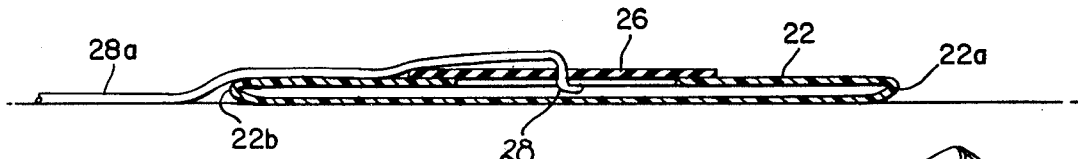

FIG. 19

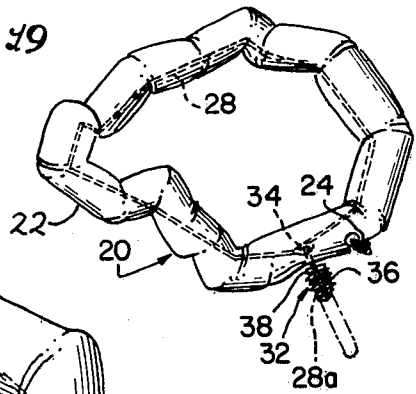
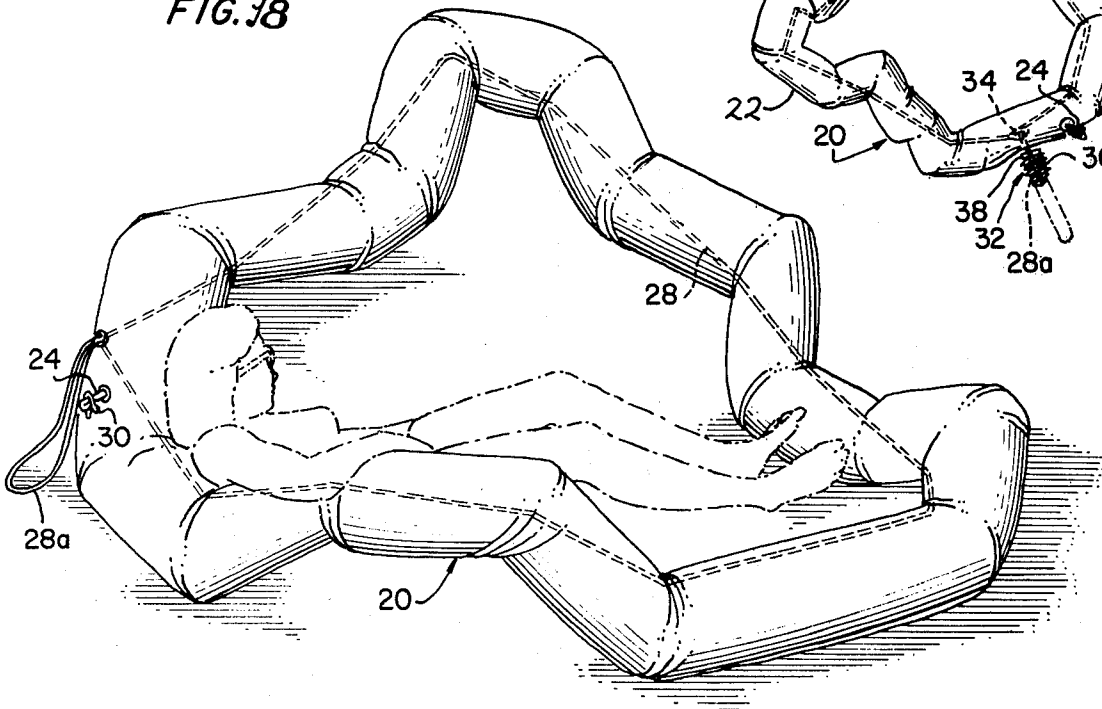

FIG. 18



INFLATABLE STRUCTURAL COMPONENT

CROSS REFERENCE TO RELATED APPLICATION

This application is a continuation-in-part of my co-pending application, Ser. No. 349,404 filed Apr. 9, 1973, now abandoned.

FIELD OF THE INVENTION

This invention relates generally to inflatable structural components that can be utilized either individually or in harmony with several other structural components to form sturdy furniture capable of assuming unique shapes.

BACKGROUND OF THE INVENTION

Inflatable furniture has gained acceptance in recent years because it is relatively inexpensive in cost, easy to clean, attractive in appearance, impervious to atmospheric conditions when used out of doors, and exhibits the ability to contour itself to properly support the body of the user of such furniture. Inflatable furniture of this general type, which employs a plurality of sealed, separate balloon-like members mechanically secured together, is shown in numerous U.S. patents, including U.S. Pat. No. 3,192,541, granted to B. S. Moore, U.S. Pat. No. 3,548,914, granted to C. P. Williams, and U.S. Pat. No. 3,670,349, granted to A. E. Moore.

Although inflatable furniture has met with some acceptance, particularly as beach or pool accessories, several structural problems have precluded conventional inflatable furniture of conventional design from realizing its full potential. For example, the balloon-like members are limited in shape to the predetermined geometry of their envelopes. The balloon-like members can only be altered or reshaped by the application of external forces to the envelope, such as by making knots in the envelope or by applying clips thereto. Even when relying upon such external forces, it has not been possible to form gentle curves in the balloon-like members, for obtuse angular bends will tend to straighten themselves out while acute angular bends will tend to become even more acute in angularity and form tight kinks in the balloon-like member.

SUMMARY

In order to combat the inherently undesirable characteristics of the plurality of mechanically interconnected balloon-like members employed in conventional inflatable furniture, the instant invention contemplates an inflatable structural component that may assume a wide variety of shapes. Such component is sturdy in nature and may be fabricated in lengths ranging from a few feet to a hundred or more feet, so that a single component may be curved into a comfortable article of aesthetically appealing form. Also, one or several components can readily be fabricated and/or joined to form tents, abstract sculptures, rafts, and a wide variety of other useful items without sacrificing the desirable characteristics of conventional inflatable furniture detailed above. Furthermore, the instant inflatable structural component is not limited to one specific shape dictated by the geometry of its envelope, but can be altered in shape as desired by the user.

In its preferred form, the present invention comprises a long tubular flexible envelope with reentrant ends held in by a tensile member running axially through the

center of the tube. As the component is folded into a desired shape the tensile member is displaced from the center of the envelope at the fold, i.e., goes to side of the envelope at the fold, and thereby allows the ends of the tube to move outward. This outward movement of the ends due to the increase in effective length of the tensile member increases the internal volume of the envelope to compensate for the decrease in volume at the fold. Thus the component may be vent with no significant change in internal volume and consequently there is very little increase in internal pressure or potential energy to provide a restoring force attempting to cause the component to unfold. Normal frictional restraints of the floor or crossovers of the component parts are sufficient to keep the component from unfolding. Thus the component can be formed into a plurality of sections as desired by the user without the necessity of providing special restraints to keep the unit in the desired configuration.

Other significant structural features and functional advantages will become apparent from the ensuing specification when construed in harmony with the accompanying drawings.

DESCRIPTION OF THE DRAWINGS

FIG. 1 is a perspective view of one embodiment of the invention folded to form a typical furniture component.

FIG. 2 is a cross sectional view of the embodiment of FIG. 1 uninflated and stretched out.

FIG. 3 is a cross section of FIG. 2 taken at 3—3 of FIG. 2.

FIG. 4 is a cross sectional view taken at 4—4 of FIG. 1.

FIG. 5 is a side view, partially sectioned, of the embodiment of FIG. 1 with but one reentrant portion, and an additional feature.

FIG. 6 is a perspective view of the embodiment of FIG. 5.

FIG. 7 is a perspective view of another embodiment of the invention.

FIG. 8 is a cross sectional view of the embodiment of FIG. 7, uninflated and stretched out.

FIG. 9 is a cross sectional view similar to FIG. 8 but inflated.

FIG. 10 is a cross sectional view taken at 10—10 of FIG. 9.

FIG. 11 is a partly sectioned side view of still another embodiment of the invented structural component, stretched out.

FIG. 12 is a cross section of the embodiment of FIG. 11 taken at 12—12 of FIG. 11, uninflated.

FIG. 13 is a perspective view of the embodiment of FIG. 11, inflated and with typical folds.

FIG. 14 is a partly sectioned view of the embodiment of FIG. 11 showing an alternate means for adjusting the length of the tensile member.

FIG. 15 is a perspective view of the component of FIG. 14 with typical folds.

FIG. 16 is a plan view of yet a further embodiment of the invention, deflated.

FIG. 17 is a cross sectional view of the component of FIG. 16 taken at 17—17 of FIG. 16.

FIG. 18 is a perspective view of the component of FIG. 16, in use.

FIG. 19 is a perspective view of the component of FIG. 16, showing an alternate means for adjusting the length of the tensile member.

DETAILED DESCRIPTION OF THE INVENTION

Referring first to FIGS. 1-4 which depict a first preferred embodiment of the invention, and which include an envelope 42, a relatively long tubular element. The term tubular is used herein to indicate an envelope having a relatively high ratio of length to cross section and is not intended to mean that the cross section is circular or uniform. Satisfactory and interesting furniture components may be fabricated using the principles of the present invention even though the envelope contains protuberances, is tapered, has side arms, or is otherwise other than a right circular cylinder. The envelope may even be continuous, i.e., toroidal. The envelope 42 is fabricated from a thin flexible material such as vinyl plastic, sheet rubber, or rubberized cloth, it only being necessary that it be flexible and essentially impermeable to the inflating medium. The inflating medium can be air, helium, or other gas or gaseous mixture, water, oil or other liquid, a semisolid or even solid particles like styrofoam beads, beans chopped sponge rubber or other stuffing. The inflating medium may be a bladder which is itself inflated. The envelope can be elastic or non elastic or a combination of both, can be of a single layer or made of multiple layers, either separable, or laminated together. An example of a multiple layer envelope is an inner envelope of plastic film and an outer layer of cloth, leather, or imitation fur, and these could be combined not only one on top of the other but side by side. The envelope may be made of reinforced or non-reinforced material, and of any thickness provided it can resist the inflating forces and retain flexibility under them. Neither does the thickness of the material have to be constant over the area of the surface.

Practical furniture components can be made with envelope sections as little as 2 inches in diameter and 2 feet in length. A unique and interesting pillow might be made in such a size. A typical size for a component to be used as a lounge may be approximately 15 inches in diameter and 23 feet in length. Some larger pieces of furniture may utilize sections 100 or more feet in length. The actual diameters and lengths used would depend on the type of use intended for the component. The dimensions cited above are not absolute limits but are given to indicate the large range of sizes which could be manufactured to advantage.

Reentrant portions 48 and 50 are preferably of the same material as the envelope 42. It has been found to be convenient to form these portions by simply cutting the envelope 42 somewhat longer than finished size, sealing the cut ends, and stuffing the sealed ends back into the envelope to form the reentrant portions 48 and 50 as shown. Reentrant portions 48 and 50 can, of course, also be made of separate pieces of material. Prior to or at the time the ends are sealed, tensile member 46 is inserted in the envelope and attached to the ends of reentrant portions 48 and 50. The tensile member 46 is flexible and may be made of any convenient material such as plastic sheeting, plastic tubing, rope, etc. As will be explained further in the discussion below as to the method of use of the invented component, it has been found that a flat strap rather than a rope like member may be preferred, since it results in a more comfortable piece of furniture.

The tensile member 46 is, of course, shorter than the length of envelope 42, but the length is not critical. Its length may be only slightly shorter than the envelope 42 or it may be much shorter, even zero. If the length of tensile member 46 is zero, the component becomes equivalent to a second preferred embodiment illustrated in FIGS. 7-10, which will be described below. The maximum length of tensile member 46 depends upon the amount of folding of the component that is to be accommodated. In general, the more folding capability desired, the shorter must be the relative length of tensile member 46. A desirable length for tensile member 46 has been found to be of the order of one third to two thirds the length of envelope 42, not including the reentrant portions. A reduction in length below this figure does not add significantly to the folding capability of the unit, so that for most economical use of material, two thirds of the envelope length would appear to be about optimum.

It is possible to permanently fill the envelope 42 with air, liquid, or other stuffing material at the time of fabrication and furnish the unit to the ultimate consumer in its final form, but a more practical approach is to provide filling means, such as valve 44, and ship the component empty for filling by the user. If semisolid filling is desired a zipper type closure, or other means as would occur to those skilled in the art could be provided.

To understand the principle of operation of the invented component, consider first an elongated tube similar to envelope 42 but without tensile member 46 or reentrant portions 48 and 50. If such a tube were inflated with air, for example, it would assume the general shape of a hot dog. If one were to bend such a filled tube into the shape as shown in FIG. 1, the internal volume would decrease because of the wrinkles which would appear at the places of bending. This reduction in volume causes an increase in internal pressure in accordance with the gas laws. An increase in internal pressure is, of course, an increase in the potential energy of the system. Since all natural systems attempt to assume the condition of minimum potential energy, the higher potential energy of the gas in the envelope will cause the envelope to return to its "hot dog" shape when released.

Contrast the above with the operation of the invented structure. When filled, the invented component assumes the general shape of a hot dog as previously, except that reentrant portions 48 and 50 are within the envelope 42, being held in by the action of tensile member 46. If the filled envelope 42 is bent to the shape of FIG. 7, the same wrinkles as previously described will appear, with the attendant reduction in internal volume. The pressure, however, will not rise as described previously because of a compensating increase in volume which accompanies the reduction.

There are two main effects involved in the compensating increase in volume which is obtained, and it should be understood that the following explanation is not intended to be a rigorous treatment of the subject, but rather a qualitative illustration of the principles affecting the increase of internal potential energy. Assume for a moment that the tensile member remains on the central axis of the envelope as the envelope is bent. As the envelope is bent, the outer surface tends to remain fixed in length, particularly in the usual case where the envelope is made of essentially non stretch-

able material. The inner surface scrunches up and becomes shorter. The central axis also becomes shorter since its length is about the average of the lengths of the outer and inner surfaces. The tensile member has not shortened, however, and therefore the reentrant ends 48 and 50 evert somewhat compensating partially for the reduction in volume at the fold.

Also the tensile member does not actually remain along the central axis as described above, but, in fact, drops toward the fold. This results in further eversion of the reentrant portions and further compensation for the reduction of volume at the fold.

Since the potential energy of the filling medium of the reentrant portions has increased but very little as a result of the eversion, there is very little tendency for the unit to unfold to its original "hot dog" shape. Thus the unit may be folded to make various unusual, interesting, and useful furniture shapes and no external means are required to maintain the desired form.

The operation of the inverted structural component has been described above as having two reentrant portions, 48 and 50. However, the component will be functional even though it has only one such reentrant portion. The operation with only one reentrant portion is identical as when two are used, and a configuration is shown in FIGS. 9 and 10 illustrating the embodiment of FIGS. 1-4 with only one such reentrant portion. Those figures also illustrate a means for varying the length of the tensile member after manufacture. The FIGS. 5 and 6 include an envelope 52, corresponding to the envelope 42 of the embodiment of FIGS. 1 through 4 and a tensile member 56, corresponding to tensile member 46. Only one reentrant portion 57 is shown, which is attached to one end of tensile member 56. As previously, the reentrant portion is preferably an extension of the envelope 52 folded inside and sealed at the point of attachment to tensile member 56.

At the other end of envelope 52 and attached thereto is sleeve 54 which may simply be another extension of the tubing which forms envelope 52, or it may be a smaller diameter tube attached to the end of envelope 52. By extending or contracting sleeve 54 and securing same to tensile member 56 at a desired point, using clip 60, the length of tensile member 56, and hence reentrant portion 57, may be adjusted so as to provide the amount of folding capability desired.

The component may be bent and formed to the shape desired as explained above in connection with FIGS. 1 through 4, and the principle of operation is identical.

As alluded to above, the tensile member is preferably in the form of a strap rather than a rope. This is for the reason that when the unit is folded, the tensile member takes a position against the side of the envelope and, if it were in the form of a rope, it would not be as comfortable to lean against as if it were in the form of a wide strap.

If the length of tensile member 46 in the embodiment of FIGS. 5 through 8 is reduced to zero, that is, if the end of reentrant portion 48 is attached directly to the end of reentrant portion 50, it will be found that the unit functions identically as explained above, with a portion of the reentrant portions acting as the tensile member 46. For convenience this will be explained as a different embodiment of the invention although in fact, it is but an extreme of the first embodiment described above.

Referring now to FIGS. 7-10, where, in FIG. 8, the component is shown in cross section, uninflated. Envelope 142 corresponds to envelope 42 of the first embodiment but tensile member 46 and reentrant portions 48 and 50 do not appear and in their place is tube 146. Tube 146 is sealed to envelope 142 at each end and may simply be another piece of tubing identical to envelope 142. A convenient method of making the assembly is to cut a piece of tubing twice as long as the desired finished length, then stuff one cut end through the tube to meet the other cut end, then seal the cut edges together.

Valve 144 provides the means for inflation, but again the unit may require a different type of access to the interior for different filler materials. FIG. 9 shows a cross section of the invented component as inflated. As can be seen, the inner tube 146 scrunches down to a rope like form for most of its length due to the pressure of the filling medium. It might be noted that reentrant portions 48 and 50 of the first embodiment scrunch down similarly when the unit is inflated. The principle of operation is identical to that previously described, the center portion of tube 146 acting the same as tensile member 46 and the ends of tube 146 performing the functions of reentrant portions 48 and 50.

All embodiments may be used as shown, with the envelope exposed or the exterior may be covered with a decorative fabric, fur, or other attractive material.

FIGS. 11-13 show still another embodiment of the inflatable structural component, such alternative embodiment being identified generally by reference numeral 62. FIGS. 11-12 show the component 62 in deflated condition, while FIG. 13 shows component 62 in inflated condition. Component 62, as best seen in FIG. 11, is a substantially elongated, flat member in its deflated condition.

Component 62 comprises an envelope 64 of essentially tubular shape having a tensile member 66 secured to one end thereof. The free end of member 66 is identified by reference numeral 66a, and clip 71, when slipped into position, prevents free end 66a of member 66 from slipping into envelope 64. The extension, and retraction, of free end 66a affects the effective length of member 66, and thus alters the amount of curvature that can be formed by the bends subsequently formed in envelope 64. FIGS. 11 and 12 show the component in its deflated condition, while FIG. 13 shows it inflated wherein envelope 64 has been formed into a variety of curves and bends.

While the embodiments of the structural component described previously were shown with the envelopes uncovered and required that the envelope be impervious to the inflating medium contained therein, component 62 is shown having a bladder 70 that must be impervious to the inflating medium, introduced therein through valve 72. A clip 74 shuts valve 72 after the filling operation has been completed. Since bladder 70 is impervious to the inflating medium, envelope 64 need not be similarly impervious. Freed from this constraint, envelope 64 may be made from a great variety of attractive and decorative materials that enhance the esthetic appeal of the structural component.

FIGS. 14 and 15 depict a variant of structural component 62, wherein clip 71 is omitted. Since envelope 64 need not be impervious to the inflating medium, the effective length of tensile member 66 can be altered by the simple expedient of pulling the free end 66a of such

member until the desired length is obtained; then a knot or other restraint is tied in the free end thereof. The free end 66a of the tensile member can pass to the exterior of component 62 through a simple eyelet 76. Also, FIG. 14 depicts a configuration wherein one end of tensile member 66 is secured to the bladder 70.

Referring now to FIGS. 16 through 19 where another embodiment of the inflatable structural component constructed in accordance with the principles of the instant invention, and indicated generally by reference numeral 20, is shown. Component 20 comprise an inflatable envelope 22 of flexible material, a valve 24 through which the envelope is inflated, a reinforced sleeve 26, and a tensile member 28 made of rope, cord, string, strapping, plastic tubing, metal filaments or similar materials.

Member 28 extends circumferentially throughout component 20 within the envelope 22. The length of the portion of member 28 within envelope 22 is the effective length, of the tensile member, for such member as it contacts the inner wall of the inflated envelope determines the sum of the angles or bends that can be formed in the inflated envelope. The number and location of the bends of the bends may be selected, and varied by the ultimate user of the component at will.

The looped end of member 28 extending outwardly through sleeve 26 and denoted by the numeral 28a, serves, in effect, as a handle for adjusting the effective length of member 28. In lieu of the looped end 28a, such segment of member 28 may terminate in a pair of free ends, and the adjustment function may be achieved by pulling or pushing member 28a through sleeve 26 and then tying a knot in free end 28a, at the desired location. Also, in place of a knot, one may employ a clip or a clamp or other restraining means to temporarily maintain the effective length of member 28 at a desired value. Alternatively, one end of member 28 can be secured to an inner wall of envelope 22 and only one free end 28a will extend outwardly through sleeve 26. Adjustment is then made by pulling or pushing the single free end 28a to attain the desired length of member 28, then knotting or clipping free end 28a to maintain said length.

As is true for the previous embodiments described, envelope 22 can be fabricated from any flexible material, such as vinyl plastic or sheet rubber, provided that such material is essentially impermeable to the inflating medium introduced through valve 24. The inflating medium can be air, helium or other gaseous mixtures, semisolid or solid particles such as styrofoam beads, beans, chopped sponge rubber or the like. Envelope 22 can be elastic or non-elastic in nature, or a combination of both, and can be made either from a single layer of material or from multiple layers which may be laminated together into a cohesive entity. An example of a multiple layer envelope might be an inner layer of plastic film and an outer layer of cloth, leather or imitation fur; the use of decorative materials on the exterior of the envelope is suggested by the herringbone pattern of shading in FIGS. 11-15, for example. Also, the thickness of envelope 22 does not have to constant throughout, and does not have to have the same flexibility throughout.

Whereas FIG. 16 and 17 show envelope 22 of structural component 20 in deflated condition, FIG. 18 shows envelope 22 in inflated condition after the desired inflating medium has been introduced through

valve 24 and the valve has been sealed by a clip or clamp 30. The effective length of tensile member 28 has already been adjusted by manually manipulating the free end, or ends, of member 28 that extend exteriorly of envelope 22 prior to the inflating operation. The adjusted length is maintained constant by tying knots or affixing clamps to member 28 and as selected by the user determines the number of curves formed in the envelope, and the total angularity of the curves.

The shorter the effective length of member 28 and the greater the force it exerts upon envelope 22, the greater the total angularity that the envelope can assume. Once the effective length of member 28 increases beyond the length of the inner wall 22b of the inflated envelope, member 28 will no longer influence the shaping of envelope 22.

FIG. 18 also indicates roughly the size of structural component 20, which may range in size from several inches to as large as 40, 50 feet or several hundred feet in length. Consequently, several persons may utilize a single component 20 as an intriguing piece of furniture, and may sit on or rest against different segments of the curved or bent envelope.

FIG. 19 shows a device 32 for adjusting the effective length of tensile member 28. Device 32 includes an eyelet 34 that permits member 28 to function as a "hangman's noose" or a lariat, so that pulling on the free end 28a of member 28 foreshortens the effective length of member 28. A flexible plastic sleeve 36, which can be extended or contracted, is an integral part of device 32, as is clip 38 which pinches off sleeve 36 and prevents free end 28a of member 28 from slipping into the interior of component 20.

Adjustment device 32 functions in the following manner. Clip 38 is removed from its normal position at the juncture of sleeve 36 and the wall of envelope 22. Then the user grasps the free end 28a of tensile member 28 through sleeve 36 and either contracts, or extends, the sleeve until the effective length of member 28 is adjusted to that length that produces the desired number of curves in envelope 22. Eyelet 34 assists in the formation of a noose of member 28 and also insures that member 28 is easily manipulated. Lastly, clip 38 is replaced and envelope 22 retains its curved shape, until the next adjustment.

While sleeve 26 in FIGS. 16-18 must be resilient in nature to pinch member 28 closed at those locations where it exits from envelope 22 in order to maintain an air-tight sleeve, adjustment means 32 overcomes this potential problem for flexible sleeve 36 traps any of the fluid medium that escapes from envelope 22. Naturally, if desired, both self-sealing sleeve 26 and flexible sleeve 36 may be used concurrently to enhance the ability of envelope 22 to retain, for prolonged periods, the inflated medium forced therein.

Since numerous additional variations in the details of the construction of the instant structural components will undoubtedly occur to the artisan in the technology to which this invention appertains, the appended claims should be broadly construed commensurate with the significant technical advances disclosed in the foregoing specification.

I claim:

1. An inflatable structural component comprising:
 - a. a tubular envelope; and
 - b. a flexible tensile member within said envelope, two spaced points along said tensile member being se-

9

cured to the ends of said envelope, the length of said tensile member between said spaced points being shorter than the distance along said envelope between said ends, whereby the longitudinal axis of said tubular envelope may be made to assume and maintain a bent configuration.

2. The structural component of claim 1 wherein at least one end of said envelope is reentrant, whereby when the longitudinal axis of said tubular envelope is bent said reentrant end of said envelope will evert.

3. The structural component of claim 1 where said tensile member is a strap.

4. The structural component of claim 1 where said envelope is 2 or more feet in length.

5. The structural component of claim 2 where said tensile member is tubular.

6. The structural component of claim 5 where said tubular tensile member is an additional length of said envelope.

7. The structural component of claim 5 where said envelope is two or more feet in length.

8. The structural component of claim 2 where said tensile member is two thirds or less of the length of said envelope, not including the reentrant portion of said envelope.

10

9. The structural component of claim 1 and further including a bladder within said envelope, said tensile member being between said bladder and said envelope.

10. The structural component of claim 1 and further including means for altering the length of said tensile member.

11. The structural component of claim 10 wherein said means for altering the length of said tensile member comprises:

a. a sleeve impervious to the inflating medium attached to one end of said envelope and communicating with the interior of said envelope, said tensile member extending into said sleeve; and

b. means for clamping said tensile member within said sleeve, whereby the length of said tensile member within said envelope may be adjusted.

12. The structural component of claim 1 where said envelope has a substantially ring like shape, said tensile member passing around said ring within said envelope and being secured to said envelope at substantially one point on said envelope, and including means for adjusting the length of said tensile member within said envelope.

* * * * *

25

30

35

40

45

50

55

60

65