

No. 607,133.

Patented July 12, 1898.

J. RICHARDS.  
CENTRIFUGAL PUMP.

(Application filed Apr. 29, 1897.)

(No Model.)

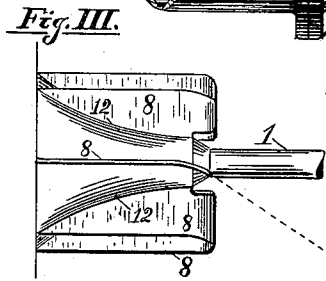
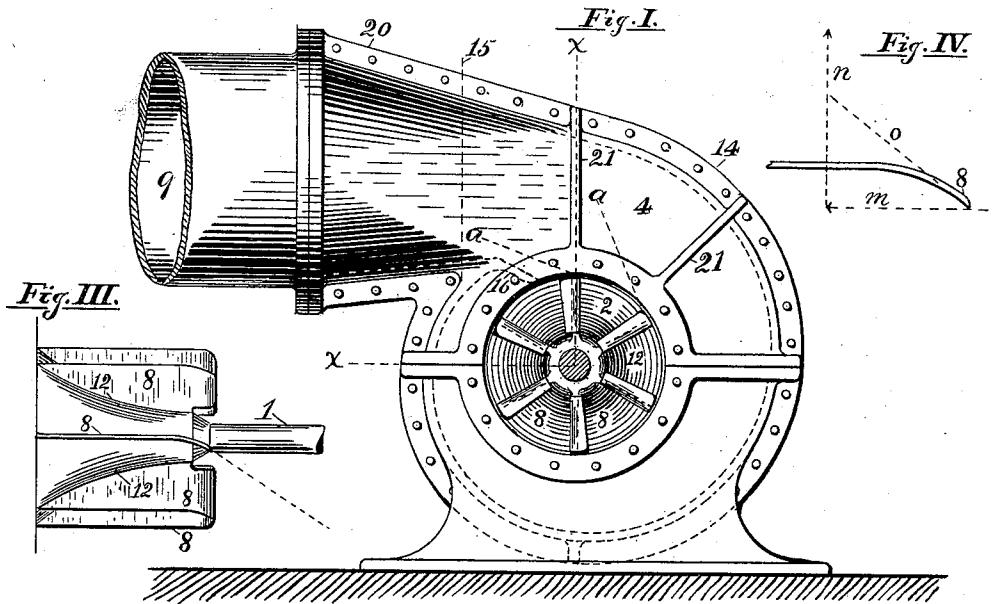
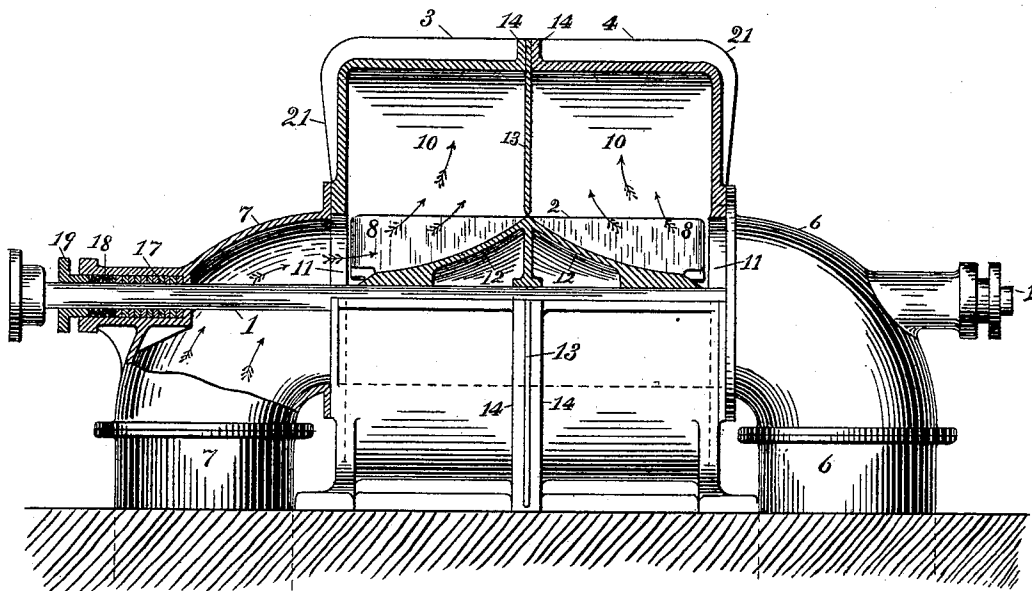

Fig. II.



Witnesses

Inventor

*K. Lockwood Stearns*

*John Richards*

*E. Sanderson*

By *Henry H. Bates*  
Attorney

# UNITED STATES PATENT OFFICE.

JOHN RICHARDS, OF SAN FRANCISCO, CALIFORNIA.

## CENTRIFUGAL PUMP.

SPECIFICATION forming part of Letters Patent No. 607,133, dated July 12, 1898.

Application filed April 29, 1897. Serial No. 634,389. (No model.)

*To all whom it may concern:*

Be it known that I, JOHN RICHARDS, a citizen of the United States, residing in the city and county of San Francisco, State of California, have invented certain new and useful Improvements in Centrifugal Pumps, of which the following is a specification.

My invention relates to improvements in rotary or centrifugal pumps whereby by certain changes in form and relative proportions of parts and in constructive details I am enabled to materially increase the speed of revolution with the same power and within the same dimensions, thereby gaining in efficiency, while effecting certain other advantages to be pointed out below.

My improvement consists, essentially, in widening the chambers of pumps of the class above named relatively to their diameters, making them rectangular in longitudinal or axial cross-section, while strictly helical in transverse section throughout, whereby I am enabled to employ a fan or impeller of much longer axis relatively to the diameter than before and to reduce the diameters in pumps of the same class, in consequence of which the relative speed of revolution may be greatly increased with resultant economy of power; also, in so dividing the chamber by a fixed transverse partition midway as to prevent eddies and cross-currents, which greatly absorb power, and, in combination with the latter, in employing an axial spindle of duplicate conoidal form and curved section, whereby the direction of the incoming current is gradually deflected toward its new course with a minimum absorption of power, while the area of the water-passages is preserved measurably uniform, and, finally, in various specific constructive features, which will be more fully pointed out in connection with the accompanying drawings, in which—

Figure I is a side elevation of a centrifugal pump made according to my invention with the front suction-pipe removed. Fig. II is a partial section through the same pump parallel to the axis and on the line  $xx$  in Fig. I. Fig. III is a side view in elevation of one end of the impeller. Fig. IV is a diagram showing the entering curved edges of the impeller-vanes.

Like numerals of reference apply to corresponding parts in the several figures.

In the drawings, which illustrate a pump of large size drawn to a reduced scale, the main casing or pump-shell is divided horizontally or in the plane of the axis and also vertically through the center. Such division of the casing or main shell into separable sections is for convenience in casting and erecting pumps of large size and also permits access laterally to the impeller 2 by lifting off the top portion of the casing composed of the parts 3 and 4. In constructing small pumps the casing can be made whole and the impeller 2 inserted from the end.

It is common in constructing centrifugal pumps to make the impeller at least twice the diameter of the pump's inlet-ways 6 and 7; but in the present case this method is abandoned, the impeller 2 being made in diameter no larger than the bore of the inlet-ways 11.

The sectional area of the discharge-way 9 and of the helical pump-chamber near the delivery, as seen at 10, Fig. II, should be equal to the combined sectional areas of both inlet-pipes 6 7. Consequently, while the cross-section of the discharge-way above the rotary impeller, near the delivery, as shown in Fig. II at 10 on line  $xx$  of Fig. I, is in the form of an elongated rectangle and may be even still more elongated, the whole is gradually converted by a suitable connection into a cylindrical exit-way of the same area in cross-section and of proper diameter, as shown in Fig. I at 9.

To prevent the sudden check of velocity consequent upon the sudden change of direction of the incoming current through the passages 11 into a pump-chamber 10 of increased cross-sectional area, I have provided the double conoidal core or spindle 12, of curved outline in longitudinal section, on which the vanes 8 are cast or mounted. This conoidal core not only serves to gradually change the direction of the incoming current radially outward into the helical chamber, but tends to maintain uniformity of cross-section between the vanes, in the angular space thereof, thereby still further operating to prevent sudden and undue check of velocity, whereby power is absorbed and neutralized. The said

core also serves to stiffen the shaft of the impeller throughout its length, which is important in view of its greatly-increased length and the need for absolute inflexibility in a shaft revolving at high speed.

The helical discharge-chamber 10 is divided centrally into two equal parts by a radial diaphragm or partition 13. This partition extends around the whole length of the helical chamber 10, from the dotted line 15 in Fig. I down to and inclosing the apex of the double conoidal core 12, and in the case of a pump made in section can be a thin plate 13, bolted between the flanges 14, as seen in the present drawings, or may, in the case of smaller pumps, be cast as an inward-projecting flange integral with the outer casing or cylinder. The purpose of this diaphragm or partition is to prevent impingement and consequent disturbances of the water entering from each end of the impeller 2 or from each side of the pump, as indicated by the arrows in Fig. II. Such impingement of the two entering columns of water is a result of the novel form of the impeller 2, by which the water is not, as in the common form of centrifugal pumps, thrown out radially or normal to the axis, but can pass into the discharge-chamber 10 at various angles, as indicated in Fig. II, and consequently avoids disturbing action and some loss of power that would occur if the plate 13 were omitted.

In Fig. III, I have illustrated one end of the conoidal core, showing one end of one of the vanes in edge view to display the forward curve given to the said vane at the extremity. The object of this curve is to enable the moving vane to enter the incoming current of water with the least possible obstruction or check. Fig. IV is a diagram in which the arrow *m* illustrates the direction of the incoming current, arrow *n* the direction of the discharge from the impeller, and line *o* the angle which the point or terminus of the curve 8 makes with the line *m*. It is apparent that if the velocity of the revolving vane were reduced to zero and inflow could continue this curve would vanish into a straight line coincident with the plane of the vane, while if the velocity of the incoming current approached to zero the angle *o* should be approximately ninety degrees. The practical angle *o* is midway between the two, dependent on the ratio of the effective angular speed of rotation of the vanes to the velocity of the incoming current maintained under the given speed of rotation, which is determinable by experiment, and does not vary greatly, since the speed of inflow is a function of the velocity of rotation of the vanes. As I have illustrated it in Fig. IV the practical angle is about thirty-eight degrees.

The angle of discharge from the impeller 2 (indicated by the dotted lines *a a*, Fig. I) is a function of the ratio of the angular velocity of the impeller-blades to the rate of flow through the discharge-way, which latter is not wholly dependent on the former, but is

modified by the amount of head or resistance. Consequently in designing the angle of the cut-off or throat-plate 16 for a given plant all these conditions are taken into account. The said throat-plate 16 may be made adjustable to different angles to suit a variable head, though not shown. These matters of shape and angles of the vanes 8 and of the cut-off or throat at 16 do not form any part of the present invention and are illustrated here to show how the present form of construction admits of easy adaptation to various heads and conditions of use.

The bearings of the pump-spindle 1 I make, preferably, of a series of rings or collars 17, that can revolve or not as their outer or inner surface meets with resistance, packing 18 and a gland 19 being provided in the usual manner.

The elongated discharge-way 10 is converted to cylindrical form by the extension 20, which can be made integral with the parts 3 and 4 or be a separate nipple bolted on.

In cases when head and pressure demand it the flat surfaces of the casing are reinforced by ribs 21, that join into the flanges 14. For moderate heads this provision is not required.

This manner of constructing centrifugal pumps leads to certain new results, as follows: The speed of revolution being inversely as the diameter of the impeller is much increased, adapting such pumps to be driven directly by electric motors, high-speed steam-engines, or the like. The weight of the revolving parts and their dimensions being inversely as the rate of revolution are much reduced in size, so, also, the cost of their construction. The cost of the main casing for such pumps is approximately as the square of their extreme diameter, which by my invention is much reduced in dimensions and is more simple in form. Favorable operating conditions—such as uniformity of velocity for the water, avoidance of abrupt changes of course, and other resistances—are not increased, but, on the contrary, are diminished by the construction herein shown and described.

What I claim as new, and desire to secure by Letters Patent, is—

1. In a centrifugal pump, a helical pump-chamber of rectangular longitudinal section and tangential discharge-way, in combination with a rotary impeller provided with radial vanes arranged oppositely in pairs of rectangular outline, said impeller being of a length relatively greater than the diameter of said pair of vanes, and an inlet-way at each end of said pump-chamber, corresponding in diameter to the outer sweep of said radial vanes, substantially as shown and described.

2. In a centrifugal pump, a helical pump-chamber of rectangular longitudinal section, having an inlet-way at each end, in combination with a rotary impeller provided with radial vanes whose outer edges describe a cylinder of a length relatively greater than its diameter, said vanes being mounted on an

axial spindle-formed core of double conoidal outline, tapering each way from the center at a point coincident with the outer margin of the vanes, on a curve, and borne on a central shaft, substantially as shown and described.

3. In a centrifugal pump, a helical pump-chamber of rectangular longitudinal section, having an inlet-way at each end, in combination with a rotary impeller provided with radial vanes whose outer edges describe a cylinder of a length relatively greater than its diameter, said vanes being mounted on an axial spindle-formed core of double conoidal outline, and a fixed partition 13 extending from the apex of the said double conoidal core to the outer wall of the said helical chamber, dividing it into two equal chambers, substantially as shown and described.

4. In a centrifugal pump, a helical pump-chamber of rectangular longitudinal section, having an inlet-way at each end, in combination with a rotary impeller provided with radial vanes whose outer edges describe a cylinder of a length relatively greater than its diameter, said vanes being mounted on an axial spindle-formed core of double conoidal outline, and having their outer ends curved toward the direction of rotation, whereby the entrance of said vanes into the incoming stream with least disturbance is facilitated, substantially as shown and described.

5. In a centrifugal pump, a helical pump-chamber of rectangular longitudinal section, having an inlet-way at each end, in combination with a rotary impeller provided with radial vanes whose outer edges describe a cyl-

inder of a length relatively greater than its diameter, said vanes being mounted on an axial spindle-formed core of double conoidal outline, supported on a central shaft, the case of said helical chamber being divided into separable sections in a horizontal plane through the said impeller-shaft, and also in a vertical plane midway and at right angles to the said impeller-shaft, substantially as shown and described.

6. In a centrifugal pump, a helical pump-chamber of rectangular longitudinal section, having a circular inlet-way at each end, in combination with a rotary impeller mounted on a central shaft, having a double conoidal spindle or core borne on said shaft, tapering outward on curves each way from a central apex, carrying radial vanes whose outer edges describe a cylinder of a diameter equal to that of the said inlet-ways, and also equal to the diameter of the apex of the said conoidal spindle, the length of the said vanes being greater than the said diameter, the ends thereof having a forward curve to facilitate their entrance into the incoming stream, and a fixed partition midway of the said chamber, extending from the outer wall thereof to and inclosing the apex of the said conoidal spindle, all substantially as shown and described.

In testimony whereof I have hereunto affixed my signature in the presence of two witnesses.

JOHN RICHARDS.

Witnesses:

JAMES L. KING,  
H. H. BATES.