

(12) PATENT
(19) AUSTRALIAN PATENT OFFICE

(11) Application No. AU 199943151 B2
(10) Patent No. 760282

(54) Title
Device to permit offpump beating heart coronary bypass surgery

(51)⁷ International Patent Classification(s)
A61B 017/00

(21) Application No: **199943151**

(22) Application Date: **1999.05.27**

(87) WIPO No: **WO99/60930**

(30) Priority Data

(31) Number	(32) Date	(33) Country
09/087511	1998.05.29	US

(43) Publication Date : **1999.12.13**

(43) Publication Journal Date : **2000.02.24**

(44) Accepted Journal Date : **2003.05.08**

(71) Applicant(s)
Guidant Corporation

(72) Inventor(s)
Paul A. Spence; Warren P. Williamson; Mark Ortiz

(74) Agent/Attorney
DAVIES COLLISON CAVE,GPO Box 3876,SYDNEY NSW 2001

(56) Related Art
EP 791330
US 5782746
WO 97/40738



INTERNATIONAL APPLICATION PUBLISHED UNDER THE PATENT COOPERATION TREATY (PCT)

(51) International Patent Classification ⁶ : A61B 17/00	A2	(11) International Publication Number: WO 99/60930 (43) International Publication Date: 2 December 1999 (02.12.99)
<p>(21) International Application Number: PCT/US99/11655</p> <p>(22) International Filing Date: 27 May 1999 (27.05.99)</p> <p>(30) Priority Data: 09/087,511 29 May 1998 (29.05.98) US</p> <p>(71) Applicant: GUIDANT CORPORATION [US/US]; 1360 O'Brien Drive, Menlo Park, CA 94025-1436 (US).</p> <p>(72) Inventors: SPENCE, Paul, A.; 5818 Orion Road, Louisville, KY 40222 (US). WILLIAMSON, Warren, P., IV; 101 Southbend Court, Loveland, OH 45140 (US). ORTIZ, Mark; 5981-7 Meadowcreek Road, Milford, OH 45150 (US).</p> <p>(74) Agents: EQUITZ, Alfred, A. et al.; Limbach & Limbach L.L.P., 2001 Ferry Building, San Francisco, CA 94111-4262 (US).</p>		<p>(81) Designated States: AU, CA, JP, European patent (AT, BE, CH, CY, DE, DK, ES, FI, FR, GB, GR, IE, IT, LU, MC, NL, PT, SE).</p> <p>Published <i>Without international search report and to be republished upon receipt of that report.</i></p>

(54) Title: DEVICE TO PERMIT OFFPUMP BEATING HEART CORONARY BYPASS SURGERY

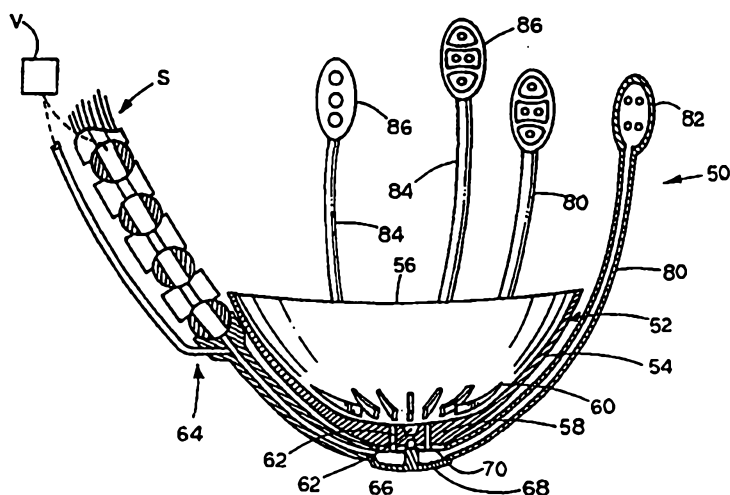

(57) Abstract

A system for manipulating a heart during cardiac surgery links lifting of the heart and regional immobilization which stops one part of the heart from moving to allow expeditious suturing while permitting other parts of the heart to continue to function whereby coronary surgery can be performed on a beating heart while maintaining cardiac output unabated and uninterrupted. Circumflex coronary artery surgery can be performed using the system for manipulating a heart during cardiac surgery of the present invention. The system is an improvement on the retractor disclosed in parent application Serial Number 08/936,184 filed on 09/17/97 and locates a suspension head near the apical region of the heart and a gross support near the base of the heart near the AV groove. A frame is positioned within the patient's thoracic region and moves with the patient, and a surgical target immobilizer can be used to assist in the movement of the heart if desired. A special suction cup is used which accommodates multiplanar movement of the heart and the myocardium while also preventing heart tissue from interrupting the suction being applied to the heart. One form of the system can be used in minimally invasive surgery.

WO 99/60930

PCT/US99/11655

**DEVICE TO PERMIT OFFPUMP BEATING
HEART CORONARY BYPASS SURGERY**

Technical Field of the Invention

The present invention relates to the general art of cardiac surgery, and to the particular field of heart retractors used in beating heart surgery.

5 Cross Reference to Related Applications

The present application is a continuation-in-part application of co-pending patent application Serial Number 08/936,184 (US Patent No. 6,019,722) filed on September 17, 1997 by the inventors of the present application. The disclosure of the just-referenced patent application is incorporated herein by reference.

10 Background of the Invention

There are as many as 300,000 coronary bypass graft procedures performed annually in the United States. Each of those procedures may include one or more graft vessels. Currently, each graft vessel must be hand sutured. As many as four or more grafts are placed in a procedure. Until recently, coronary artery bypass procedures have been performed with the patient on cardio-pulmonary bypass whereby the heart is stopped with cardioplegia and the surgery performed on an exposed and still heart.

Some pioneering surgeons are performing procedures in which the coronary bypass is performed on a beating heart. That is, without heart-lung bypass and cardioplegia. This minimizes the time it takes to perform the procedure and reduces the cost of the operation by eliminating the heart-lung bypass machine.

25 Coronary Artery Bypass Grafting (CABG) is performed and a new blood supply to the heart muscle is established when coronary



arteries are blocked with calcium or plaque. A new blood supply conduit is joined to the diseased coronary, distal to the blockage, thus providing a fresh supply of oxygenated blood to the vessel in question. Today, this is accomplished by hand suturing a graft vessel (the new supply of blood) to the diseased vessel. This junction is called an anastomosis of vessels. Many different types of supply conduits can be used. Examples are cadaver vein, saphenous vein, radial artery, internal mammary artery, and the like.

By way of background, the basic operation of a heart will be briefly discussed. The heart works like a pump. The left and right ventricles are separate but share a common wall (the septum). The left ventricle is thicker and pumps the blood into the systemic circulation. The work it performs is much greater than the right ventricle. The right ventricle pumps blood into the pulmonary circulation, which is a low pressure circuit. The left ventricle wall (a low energy system) is much thinner than the right ventricle.

The left ventricle fills in diastole and ejects in systole. The difference between the diastolic volume (largest) and the systolic volume (smallest) (the stroke volume or amount of blood ejected on each heartbeat) multiplied by heart rate determines the cardiac output of the heart (liters/min. of flow). The heart shortens during systole as the muscle contracts. There are a number of motions during contraction (including a considerable amount of rotation) but for practical purposes the heart can be

thought of as a truncated cone. Shortening occurs along its length and also along its diameter. For purposes of this disclosure, the more important of the two motions is the shortening along the diameter since the ejection volume varies as the square vs. along the length which varies with the first power.

The heart functions well whether the person is upright, upside down, prone or supine. It sits inside the pericardium - a sac which limits its motion and spreads the support on the heart so that no matter how a person positions himself, it is not particularly compressed and is able to fill and then eject with each heartbeat. The concept of the pericardium spreading the load is critical, i.e., when lying supine, the posterior pericardium supports the heart over a large surface of the heart just as when the person is lying on his stomach, the front of the pericardium spreads the load.

When the chest is opened by a median sternotomy it is possible to gain access to all chambers and surfaces of the heart. This combined with the fact that this incision is usually less painful than a thoracotomy (rib separation), makes this the preferred surgical approach to the heart.

The coronary vessels are surface vessels, only occasionally dipping into the myocardium making them accessible without opening the heart. Traditionally, bypass surgery is done with the heart arrested. This stops the motion of the heart and allows the arrest of the coronary circulation so the surgeon sews in a

bloodless and easy to see field. Since the heart is stopped, the patient would suffer irreversible damage to the brain and other tissues and organs without the use of the heart-lung machine to support the general circulation. Although the heart-lung machine
5 has been refined, it is particularly toxic to older and debilitated patients and it is expensive.

It is possible to perform surgery off bypass, while the heart is beating and the coronaries are under positive blood pressure; however, there may be problems. One problem is that not
10 all vessels are accessible since some vessels are on the posterior or inferior surfaces and that when such vessels are brought into view by lifting the heart, cardiac performance is impaired such that the cardiac output falls and blood pressure drops. A second problem is that the heart moves so that suturing
15 in vessels (12 to 15 stitches in a vessel under 2 mm in diameter) might be inaccurate and a third problem is that there is blood in the field as the coronary circulation is not interrupted. This last problem is now largely solved by snares, which temporarily stop the flow of blood through the targeted arteries. The problem
20 of lifting the heart is not to impair the performance of the heart while at the same time adequately exposing the heart and regionally immobilizing the vessel during beating heart surgery, and this problem is not solved with any prior art system.

For the heart to be effective, it must have adequate
25 biventricular function (both right and left ventricles). The left ventricle pumps into the high resistance systemic circulation and

is thicker and generates considerably more energy than the right
ventricle. It is primarily circular in cross section. This
displacement of blood (and thus heart output) depends on
shortening in the short axis (diameter of the cross section) and
5 to a lesser degree on shortening in the long axis (apex to base).
There is also rotational motion to the heart as it contracts,
thus imparting multiplanar motion to the heart as it beats; still
further, the surface of the heart undergoes multiplanar movement
during operation of the heart. The right ventricle pumps into the
10 lower resistance pulmonary circulation and is much thinner and
its energy generation is much less than that of the left
ventricle. Function of both of these ventricles must be
maintained during surgical manipulation of a beating heart.

Therefore there is a significant need for a means and a
15 method for moving a beating heart so as not to impair the
performance of the heart while at the same time adequately
exposing the heart and regionally immobilizing a vessel during
beating heart surgery.

Lifting of the heart is deleterious to heart function for
20 several reasons. First, the lifting of the heart impairs the
venous return to the heart so that there is less diastolic
filling of the heart (this can largely be corrected by putting
the head down and the feet up to increase venous return). Second,
the heart is distorted. Using a hand or spatula to lift the heart
25 is quite different than simply changing body position when the
heart is inside the chest. The force applied by the hand to the

heart is localized so that the heart is no longer a truncated cone, but is much flatter. This shape is much less effective for ejection (the circle is the most effective as it has the highest ratio of volume to diameter) and flattening also limits the diastolic volume so that inadequate filling occurs. Third, lifting pressure applied to a beating heart may deleteriously affect valve function of the heart, in particular, the mitral valve function may be adversely affected by such lifting.

In order to perform cardiac surgery on a beating heart, there is a need to lift, support and orient the heart without reducing its ability to function. Therefore, there is a need for a means and method to move and orient a beating heart into position so any vessel of the heart can be accessed without unduly interfering with the operation of the heart, especially the mitral valve function.

In coronary bypass operations, grafts have to be anastomosed to the anterior descending artery (right coronary artery branch), the circumflex artery, and to the posterior descending artery. The anterior descending artery lies on the front surface of the heart and is easily accessible to the surgeon without particular help from surgical assistants or using any devices. The circumflex and posterior descending arteries, however, lie on the back surface of the heart. Therefore, to expose the circumflex artery to a field of view of the surgeon, it is mandatory to lift the heart and rotate it about the axis of the inferior vena cava and the superior vena cava. Likewise, to expose the posterior

descending artery, it is necessary to lift the heart and rotate it in the direction of its apex. If the heart is moved improperly, it may go into fibrillation.

Ordinarily, a surgical assistant is employed to lift the heart by using his or her hand, this is satisfactory for an arrested heart. However this is not satisfactory for a beating heart. However, it is very difficult and tiring to keep the heart in a steady position. Furthermore, the myocardium in contact with the assistant's fingers may be damaged by pressure, avulsion, and premature rewarming. Further, the assistant's hand in the operative field can get in the way, and the assistant, who often stands next to the surgeon may restrict the surgeon's movements.

To date, with the exception of the device disclosed in the parent application, devices that have been directed toward facilitating beating heart surgery have been very simple stabilization platforms. A two-tined fork is the simplest and works well on directly exposed vessels such as the LAD. Another device is comprised of a hollow support tube which can be clamped outside the patient's body cavity. The support tube terminates in a suction head with a number of suction ports arranged in a linear row in such a way that they resemble the suction cups of an octopus. These suction heads are attached to the myocardium and ideally allow the heart to be regionally immobilized on either side of the target artery. This allows for a very localized stabilization of an artery to perform an anastomosis. This tool accomplishes the requirements for immobilizing the

target artery for surgery. However, this tool is inadequate for actually lifting the heart to gain access to vessels located on the posterior and lateral surfaces (circumflex and right coronary distributions). This device really is a local stabilizer, and cannot be adequately employed to assist in the lifting or moving of the heart, which is necessary in some instances, such as for a large heart, or the like. However, it has also acquired another role, that of vessel presentation. Unfortunately, the device was not implicitly designed for this function. Vessel presentation during beating heart surgery is a different function and more complex since it must allow the entire heart to function. Yet it is the more commercially valuable application of this tool since there are no other mechanical stabilizers available which are simple and acceptable to lift the functioning heart to access all vessels and eliminate the need for cardio-pulmonary bypass.

Therefore, there is a need to provide a tool that is commercially viable and which can be used for vessel presentation, and which can be used to assist in lifting and/or orienting the heart when needed.

The surgeon would like a very localized, immobilized area, such as one to two cm, on either side of the target vessel. The above-mentioned tool immobilizes the heart transmurally for a distance of two to 3 cm on each side. Small suction heads, like the surgeon prefers for local immobilization, unfortunately cannot lift the heart and larger suction heads impair heart function by immobilizing too large an area around the suction

head. If several rigid heads are used circumferentially around the heart in order to lift it, a large amount of the heart is prevented from contraction. This will immobilize too much of the heart circumference to maintain effective heart function.

5 Therefore, there is need for a means and method for immobilizing a particular area on the heart without unduly interfering with the functioning of the heart, and which can be used to lift the heart as well, again, without interfering with the operation of the heart. There is also a need for a system for
10 manipulating a heart during cardiac surgery which will support the heart in position for coronary bypass surgery of the circumflex coronary artery and posterior descending artery.

 Still further, the myocardium of a beating heart undergoes multiplanar movement and motion during operation of the heart. A
15 suction cup applied to such a moving surface may have a tendency to become separated from the myocardium thereby interrupting the suction being applied to the heart. Such interruption of suction may interfere with the attachment of the device to the heart.

 Therefore, there is a need for a means and method for
20 manipulation of a heart during cardiac surgery that will not be impaired by movement of the myocardium during operation of the heart.

 One remedy for this problem is to make the suction cups larger. However, this is not practical since too much of the
25 myocardium might be influenced by such a solution.

 Therefore, there is a need for a means and method for

manipulation of a heart during cardiac surgery that will not be impaired by movement of the myocardium during operation of the heart, while influencing a minimum amount of the myocardium.

Another prior art method of supporting a heart is by use of a sling. A sling is a network of fabric or plastic that is placed around the heart in the manner of a hammock. The heart is then supported by the sling. It is noted that in order for a sling to work as a retractor, the surgeon is required to arrange the ties to be pulled from the proper direction, such as normal to the desired direction of lift, which can be onerous. This presents a serious problem since there are no easy reference points above the patient in which to attach these ties.

While the art has included several inventions intended to support the heart during coronary bypass surgery of the circumflex coronary artery, these inventions have several drawbacks that have hindered their acceptance in the art. For example, the use of nets to support the heart exposes the heart to fine stands which impinge on the heart and may cause damage. Furthermore, nets may impede the surgical target and require special techniques or procedures to remove the net from the surgical target area. This is especially onerous if the net mesh is fine. Flat cloth tapes are a form of net, and may damage the heart due to a rough texture of the cloth and the small area of contact between the tape strands and the heart. Further, tapes and similar devices that do not have large surface areas contacting the heart may not support the heart in a uniform

manner and may create large pressure areas at the contact points.

Therefore, there is a need for a manipulation system for use in cardiac surgery which will support the heart in position for coronary bypass surgery of the circumflex coronary artery in a manner that tool not damage the heart yet will provide easy access to the surgical target and keeps working while cardiac output is maintained.

Still further, some prior art means for supporting the heart during cardiac surgery may tend to interfere with ventricle operation.

Therefore, there is a need for a means and a method for manipulating a heart during cardiac surgery which will not interfere with ventricle operation of the heart while a beating heart is supported in position and orientation for surgery.

The parent disclosure discussed a means and method for lifting the heart during surgery. This means and method included a gross support means for engaging the apex portion of the heart and which is fixed to a stationary element, such as the operating table or the like. The preferred form of the gross support means includes a cup-shaped element that fits around the apex of the heart to support the weight of the heart and which is attached to a source of suction.

The means and method disclosed in the parent disclosure work well, but the inventors have since discovered that it would be beneficial to the overall success of beating heart surgery to contact the least amount of myocardium as possible in moving the

heart for surgery.

A further consideration in coronary artery surgery is hemorrhage from the incision into the coronary artery at the proposed anastomotic site. Therefore, heretofore, coronary artery surgery has been carried out under conditions of cardiac arrest and aortic root cross clamping. Hence, the myocardium is temporarily deprived of coronary blood supply. In some patients, an additional coronary blood supply, through the form of bronchial circulation, causes significant hemorrhage during the bypass grafting process. This hemorrhage is inconvenient, as it masks the surgeon's view during the delicate suturing process, and threatens the well-being of the patient. Performing surgery in this manner has several additional drawbacks, including the need to stop the heart, the need to insert special equipment and procedural steps to carry out the function of moving blood through the patient's body while the heart is stopped.

Therefore, there is a need for a heart retractor which will support the heart in position for coronary bypass surgery of all of the coronary arteries, including the circumflex coronary artery, in a manner such that the tool does not damage the heart while cardiac output is maintained yet will provide easy access to the surgical target and which can be used in a manner that does not require the heart to be stopped.

Still further, there is a need for a system for manipulating the heart during cardiac surgery which permits regional as well as specific immobilization of the heart.

However, the continued operation of the heart will produce problems, in addition to the above-discussed problems, of forming a moving target for the surgeon. That is, since the heart continues to beat during the operation, the surgical target will
5 move in connection with such beating movement. The heart cannot be stopped or unduly constrained without increasing the danger of fibrillation.

Therefore, there is a need for a system for manipulating the heart during cardiac surgery which will support a beating heart
10 in position for coronary bypass surgery of coronary arteries in a manner that will not damage the heart yet will provide specific and regional support while allowing unabated cardiac output.

Recently, there has been interest in minimally invasive coronary bypass surgery. This is not surprising since a median
15 sternotomy and a run on the cardiopulmonary bypass pump are not well tolerated by some patients, combined with the added cost of coronary bypass equipment and staff. The procedure results in considerable recovery time and is associated with a risk of death and major complication. While the ultimate goal is to provide
20 bypass to all vessels by port access (like gallbladder surgery) and to eliminate the need for cardiopulmonary bypass, a more limited but reasonable option for the next number or years will be to perform bypass off pump with an incision (sternotomy or thoracotomy). A tool which could allow performance of multivessel
25 off pump bypass would be most helpful.

Therefore, there is a need for a heart retractor which will

WO 99/60930

PCT/US99/11655

support the heart in position for minimally invasive coronary bypass surgery of coronary arteries, including the circumflex coronary artery, in a manner that will not damage the heart yet will provide easy access to the surgical target without requiring
5 the heart to be stopped yet without unduly constraining the heart.

Still further, the inventors have observed that not all hearts are the same size, shape and have the same spacing between corresponding areas. Thus, while all hearts are basically the
10 same, there may be a variation between individual hearts. Therefore, a device that supports a heart should account for these variations. This is especially true if the heart is to continue pumping during the operation and while it is supported. If the support is not fit to the particular heart, it may
15 constrict the heart in some manner and thus interfere with the continued output of the heart.

Therefore, there is a need for a system for manipulating a heart during cardiac surgery which will support a heart, especially a beating heart, during cardiac surgery and which can
1 20 be adjusted to fit the particular needs of the individual heart and will support the heart both in gross and regionally.

Objects of the Invention

The present invention advantageously provides a system for manipulating a heart during cardiac surgery which will
25 support the weight of a beating heart and maintain cardiac output unabated and uninterrupted even though the heart is maintained in



P:\WPDOCS\CRM\Parita\Spec\175518590.spc.doc-06/03/03

an unnatural position and/or orientation.

It also improves the retractor disclosed in the parent disclosure.

The present invention advantageously provides a system
5 for manipulating a heart during cardiac surgery which will support a beating heart in position for coronary bypass surgery and which can support the heart both regionally and in gross.

The present invention also provides a system for
10 manipulating a heart during cardiac surgery which will support a beating heart in position for coronary bypass surgery and which can support the heart both regionally and in gross and which can account for variations in individual hearts.

15 The present invention also provides a system for manipulating a heart during cardiac surgery which will support a beating heart in position for coronary bypass surgery of the coronary arteries, including the circumflex coronary artery.

20 The present invention also provides a system for manipulating a heart during cardiac surgery which will support the heart in position for coronary bypass surgery of the coronary arteries in a manner that will not damage the heart yet will provide easy access to the surgical target.

25 The present invention also provides a system for manipulating a heart during cardiac surgery which will support the heart in position for coronary bypass surgery in a manner that will not damage the heart yet will provide easy



P:\WPDOCS\CRNP\Patent\Spec\7558590.rpe.doc-06/03/03

access to the surgical target and which can be used in a manner that does not require the heart to be stopped.

The present invention also provides a system for manipulating a heart during cardiac surgery which can
5 support the heart while maintaining competent mitral valve function.

The present invention also provides a system for manipulating a heart during cardiac surgery which will support the heart in position for coronary bypass surgery in
10 a manner that prevents collapse of the right ventricle during manipulation of the heart.

The present invention also provides a system for manipulating a heart during cardiac surgery which will support the heart in position for coronary bypass surgery in
15 a manner that will not damage the heart yet will provide easy access to the surgical target without requiring the heart to be stopped yet without unduly constraining the heart.

The present invention also provides a system for
20 manipulating a heart during cardiac surgery which will support the heart in position for minimally invasive coronary bypass surgery in a manner that will not damage the heart yet will provide easy access to the surgical target without requiring the heart to be stopped yet without unduly
25 constraining the heart.

The present invention also provides a system for manipulating a heart during cardiac surgery which will



P:\WPDOCS\CRN\Patent\Spec\7358590.spe.doc-06/03/03

provide regional and specific immobilization of the heart.

The present invention also provides a system for manipulating a heart during cardiac surgery which will
5 isolate one region of the heart while allowing cardiac output to be sustained.

The reference to any prior art in this specification is not, and should not be taken as, an acknowledgement or any form
10 of suggestion that the prior art forms part of the common general knowledge in Australia.

Throughout this specification and the claims which follow, unless the context requires otherwise, the word "comprise",
15 or variations such as "comprises" or "comprising", will be understood to imply the inclusion of a stated integer or group of integers or steps but not the exclusion of any other integer or group of integers or steps.

20 Summary of the Invention

The invention provides a heart positioning device for use in cardiac surgery on a beating heart, comprising: a suction head adapted to positively engage the beating heart; an arm which is flexible in an unlocked condition and rigid
25 in a locked condition; and a spring suspension connecting said suction head to said arm.

The invention also provides a heart manipulation system for use in cardiac surgery, comprising: a sternal retractor; a suction head adapted to engage an apical region
30 of the heart; an arm which is flexible in an unlocked condition and rigid in a locked condition; a suspension mechanism connecting said suction head to said arm; and an



P:\WPDOCS\CRM\Patent\Spec\7558590 spe.doc-06/03/03

attachment mechanism adapted to fix said arm to said sternal retractor; wherein said suction head is free to move, relative to said arm via said suspension mechanism, even when said arm is in said locked condition.

5 The invention further provides a heart positioning device adapted to suspend a heart from an apical region of the heart, for use in cardiac surgery, said device comprising a cup shaped head adapted to engage the heart and being suspended from an arm which is flexible in an unlocked
10 condition and rigid in a locked condition.

 The invention further provides a retractor for use in heart surgery comprising: a rigid gross support means for engaging a heart to support the heart when the heart is oriented for surgery and including a multipositional support
15 element fixed to a stationary support; means for immobilizing selected portions of the heart while permitting non-immobilized portions to move in a manner that continues heart operation; and a surgery target immobilizing means connected to said support element and engaging the heart
20 adjacent to a surgery target for immobilizing the heart at and immediately adjacent to the surgery target whereby the heart is supported and free to operate during surgery while being locally immobilized at the surgery target.

 The invention further provides a heart retractor for use
25 in heart surgery comprising: support means for supporting the gross weight of a heart to support the heart when the heart is oriented for surgery and including a main support arm having means at one end thereof for mounting the support arm on a stationary support; and means for immobilizing
30 selected portions of the heart and permitting other sections to move as required to continue heart operation during surgery, said immobilizing means including at least one



P:\WPDOCS\CRN\Funil\Spec\7558590.spe.doc-06/03/03

rigid support arm connected at one end thereof to said support means and having means thereon for releasably attaching said rigid support arm to the heart, and at least one flexible support arm connected at one end thereof to
5 said support means and having means on another end thereof for releasably attaching said flexible support arm to the heart.

The invention further provides a retractor for use in minimally invasive heart surgery comprising: support means
10 for engaging a heart to support the heart when the heart is oriented for surgery and including a handle having a distal end and a proximal end, said proximal end being located outside of a patient during surgery, a support element fixed to said distal end, and rigid elements fixed to said distal
15 end and engaging and supporting chosen sections of the heart; and means for immobilizing selected portions of the heart while permitting non-immobilized portions to move in a manner that continues heart operation whereby the heart is supported and free to operate during minimally invasive
20 surgery while being immobilized at selected locations.

The invention further provides a retractor for use in heart surgery comprising: support means for engaging a heart to support the heart when the heart is oriented for surgery and including a support element fixed to a stationary
25 support and rigid elements engaging and supporting chosen sections of the heart; means for immobilizing selected portions of the heart while permitting non-immobilized portions to move in a manner that continues heart operation

whereby the heart is supported and free to operate during
30 surgery while being locally immobilized at the surgery target.



P:\WPDOCS\CRM\Punita\Spec\7558590.apc.doc-06/03/03

The invention further provides a heart positioning device for use in cardiac surgery comprising: support means for engaging a heart to support the heart when the heart has been oriented into an unnatural position or orientation for coronary surgery; means for attaching said support means to the heart so the heart operates with uncompromised ventricular function when the heart is oriented into an unnatural position or orientation for coronary surgery; means engaging sections of the heart to immobilize the sections engaged while permitting non-engaged sections of the heart to move in a manner whereby essentially unabated cardiac output is maintained during surgery while the heart is regionally immobilized.

The invention further provides a heart retractor for use in heart surgery comprising: support means for engaging an apex portion of a heart to support the heart when the heart is lifted for surgery and including a main support arm having means at one end thereof for mounting the support arm on a stationary support; and means for immobilizing selected portions of the heart and permitting other sections to move as required to continue heart operation during surgery, said immobilizing means including at least one rigid support arm connected at one end thereof to said support means and having means on another end thereof for releasably attaching said rigid support arm to the heart, at least one flexible support arm connected at one end thereof to said support means and having means thereon for releasably attaching said flexible support art to the heart.

The invention further provides a retractor for use in heart surgery comprising: a main support; a gross support means for engaging a heart and supporting the heart when the heart is oriented for surgery, said gross support means



P:\WPDOCS\CAN\PatIn\Spec\7558390.spc.doc-06/03/03

being attached to said main support; a fine support means for supporting portions of the heart during surgery, said fine support means being attached to said gross support means with non-supported portions of the heart moving in a
5 manner whereby essentially unabated cardiac output is maintained during surgery while the heart is regionally immobilized at supported portions and including rigid elements engaging and supporting chosen sections of the heart.

10 The invention further provides a retractor for use in heart surgery comprising: a main support; a gross support means for engaging a heart and supporting the heart when the heart is oriented for surgery, said gross support means being attached to said main support and including means for
15 adjusting the shape of said gross support means; a fine support means for supporting portions of the heart during surgery, said fine support means being attached to said gross support means with non-supported portions of the heart moving in a manner whereby essentially unabated
20 cardiac output is maintained during surgery while the heart is regionally immobilized at supported portions and including rigid elements engaging and supporting chosen sections of the heart.

The invention further provides a heart positioning
25 device for use in cardiac surgery comprising: a stationary support; a rigid arm connected to said stationary support; a flexible element connected to said rigid arm; means on said flexible element for releasably attaching said flexible element to a heart to orient the heart into an unnatural
30 position or orientation for coronary surgery and so the heart operates with uncompromised ventricular function when



P:\WPDOCS\CRNP\Patent\Spec\7558590.spc.doc-06/03/03

oriented into the unnatural position or orientation during coronary surgery.

The invention further provides a heart positioning device for use in cardiac surgery comprising: a stationary support for orienting the heart into an unnatural position or orientation for coronary surgery; a flexible element connected to said stationary support for supporting the heart in a manner so the heart operates with uncompromised ventricular function when the heart is oriented into the unnatural position during coronary surgery; and means on said flexible element for releasably attaching said flexible element to the heart.

The invention further provides a heart positioning device for use in cardiac surgery comprising: a stationary support for orienting the heart into an unnatural position or orientation for coronary surgery; a rigid arm connected to said stationary support; a flexible element connected to said stationary support; means on said flexible element for releasably attaching said flexible element to a heart in a manner so the heart operates with uncompromised ventricular function when the heart is oriented into the unnatural position during coronary surgery.

The invention further provides a heart positioning device for use in cardiac surgery comprising: a stationary support; a flexible element connected to said stationary support for supporting a heart in a manner so the heart operates with uncompromised ventricular function when the heart is oriented into an unnatural position or orientation during coronary surgery; and means on said flexible element for releasably attaching said flexible element to the heart.

The invention further provides a heart positioning device for use in cardiac surgery comprising: a stationary



F:\WPDOCS\CRM\Patent\Spec\7558590.1pe.doc-06/03/03

support; a flexible element connected to said stationary support for supporting a heart in a manner so the heart operates with uncompromised ventricular function when the heart is oriented into an unnatural position or orientation during coronary surgery; and means on said flexible element for releasably attaching said flexible element to the heart.

The invention provides a system for manipulating a heart during cardiac surgery which suspends the heart from the apical region near the right ventricle and prevents collapse of the right ventricle during the manipulation. The heart can be supported by this suspension, but also has a gross support that is located near the left ventricle and extends along the arterialventricular (AV) groove to lift and rotate the heart while supporting the mitral valve annulus to maintain competent valve function of the mitral valve. The two-point support can thus be provided in a manner that maintains cardiac operation unimpeded. Still further, the system can include a surgical target immobilizing means that is, itself, capable of assisting in the lifting of the heart under some circumstances and thus can be used to assist in the movement of the heart during cardiac surgery. The location and design of the elements of the system of the present invention achieves the lifting and orienting of the heart in a manner that presents the heart in the most advantageous position and orientation for surgery while permitting the heart to maintain cardiac output in an essentially unabated manner. This provides a stationary target for the



P:\WPDOCS\CRN\Patia\Spec\7558590.apc.doc-06/03/03

support; a flexible element connected to said stationary support for supporting a heart in a manner so the heart operates with uncompromised ventricular function when the heart is oriented into an unnatural position or orientation
5 during coronary surgery; and means on said flexible element for releasably attaching said flexible element to the heart.

The invention provides a system for manipulating a heart during cardiac surgery which suspends the heart from the apical region near the right ventricle and prevents collapse
10 of the right ventricle during the manipulation. The heart can be supported by this suspension, but also has a gross support that is located near the left ventricle and extends along the arterialventricular (AV) groove to lift and rotate the heart while supporting the mitral valve annulus to
15 maintain competent valve function of the mitral valve. The two-point support can thus be provided in a manner that maintains cardiac operation unimpeded. Still further, the system can include a surgical target immobilizing means that is, itself, capable of assisting in the lifting of the heart
20 under some circumstances and thus can be used to assist in the movement of the heart during cardiac surgery. The location and design of the elements of the system of the present invention achieves the lifting and orienting of the heart in a manner that presents the heart in the most
25 advantageous position and orientation for surgery while permitting the heart to maintain cardiac output in an essentially unabated manner. This provides a stationary target for the



surgeon while supporting the heart in a safe manner and in a manner that does not interfere with the surgeon or his field of sight. In this manner, the system of the present invention can be used to support a heart during cardiac surgery without requiring an assistant to hold the heart, yet will permit the surgical procedure to be carried out without requiring cardiac arrest.

Furthermore, the system of the present invention includes a frame that is located within the patient's thoracic cavity whereby movement of the patient automatically moves the heart supporting elements in a corresponding manner. This maintains the surgical work field clear and automatically repositions and reorients the heart supporting elements as the patient is moved. This efficiently keeps the heart supported during surgery.

More specifically, a first form of the system for manipulating a heart during cardiac surgery includes an element that can be cup-like and which has a flexible rim that engages the myocardium of the heart in a manner that maintains the engagement even while the myocardium moves during heart operation. Still further, the cup-like element is designed so that heart tissue will not interfere with the operation of the element. The cup-like element applies suction to the heart to hold the element associated with the cup-like element on the heart. The cup-like element is used in connection with the suspension head discussed above as well as in connection with the surgery target immobilizing element. Flexible means on the cup-like element permit that element to move to accommodate

multiplanar movement of the heart during operation of the heart. Still further, the gross support means may also use suction to hold the support against the heart. If used, the suction interface is designed so heart tissue will not interfere with the suction applied via the gross support means. The design of the suspension head, the suction cups and the surgical target immobilizing means is such that the system of the present invention can accommodate an individual heart and is amenable to use on hearts of different sizes, weights and even locations. In this manner, a heart, especially a beating heart, can be supported in the manner that is most effective for that particular heart. Thus, in the case of a beating heart, cardiac output can be maintained in an unabated and uninterrupted manner as there will be virtually no constrictions on the heart because the support will be perfectly fitted the particular heart.

15 A form of the system of the present invention can be used in minimally invasive surgery. The system may include a handle on the gross support means to move the gross support means as required, and a handle can be placed on the target-immobilizing means to move that means as necessary as well. The distal ends of a handles are located to provide access to th ehandle while remaining unobtrusive during surgery. Detachable handles could also be used whereby the handles are revoved after correct placement of the head.

While this invention is disclosed in the preferred form for open chest procedures for beating heart surgery, it may also be utilized for 25 minimally invasive procedures as well as those that use cardioplegia due to its novel time saving and enabling features. It is also noted that

this disclosure is not directed to the art of anastomosis per se. However, it is directly related to enabling a surgeon to perform an anastomotic procedure in a precise and controlled manner.

5 The inventive device disclosed herein eliminates the need for use of the heart-lung machine. It allows a surgeon to lift and displace the heart to expose all vessels to regionally immobilize them for suturing without seriously impairing heart performance.

The advances made using the retractor disclosed in the parent disclosure are thus improved.

10 Once the stabilization of the beating heart has been achieved as with the system of the present invention, it then becomes more feasible to entertain the idea of performing this surgery in a minimally invasive manner precluding the need for the median sternotomy.

15 Brief Description of the Drawing Figures

Figure 1 illustrates blood flow in a normal heart.

Figures 2A-2E illustrate the pumping action of a normal heart.

20 Figure 3 is a sectional elevational view of the system for manipulating a heart during cardiac surgery disclosed in the parent application.

Figure 4 is a bottom view of the system for manipulating a heart during cardiac surgery disclosed in the parent application.

25 Figure 5 is a perspective view of the system for manipulating a heart during cardiac surgery of the parent application in place on a heart.

Figures 6A and 6B illustrate operation of a prior art suction cup.

Figures 7A and 7B illustrate operation of a multipart suction cup embodying the present invention.

5 Figure 8 is a perspective view of a system for manipulating a beating heart during cardiac surgery embodying the present invention.

Figure 9 is an elevational view of the system for manipulating a heart during cardiac surgery in place on a heart.

10 Figure 10 shows the Figure 8 retractor in place in a patient.

Figure 11 is a view taken along line 11-11 of Figure 10.

Figure 12 shows a portion of the gross support means of the retractor of the present invention.

15 Figure 13 is a top plan view of the flexible head of the gross support means of the retractor.

Figure 14A is a view along line 14A-14A of Figure 13 showing the mesh means that prevents heart tissue from interrupting suction applied to maintain the gross support means in place on the heart.

Figure 14B is an exploded view of the gross support means shown in Figure 12.

Figure 14C is an exploded view of the gross support means in larger detail.

25 Figure 15 shows a portion of a preferred form of the mesh means.



Figures 16A and 16B show the flexible multisection suction cup of the present invention.

Figure 17 shows another form of the multisection suction cup.

5 Figures 18A and 18B show another configuration of the flexible suction cup of the present invention.

Figures 19A and 19B show another form of the multisection suction cup.

10 Figures 20A and 20B show another form of the multisection suction cup.

Figures 21A and 21B show another form of the multisection suction cup.

Figures 22A and 22B show another form of the multisection suction cup.

15 Figure 23 shows a bottom plan view of a prior art tool used to immobilize a section of a beating heart to define a surgical target.

20 Figure 24 is a bottom plan view of a means of the present invention for immobilizing a surgical target area of a beating heart.

Figure 25 is an elevational view of the means of the present invention for immobilizing a surgical target area.

Figure 26 is a perspective view of an alternative form of the retractor of the present invention.

25 Figure 27 shows an alternative form of the system for manipulating the heart during cardiac surgery embodying the

present invention.

Figure 28 is a top view of the system shown in Figure 27.

Detailed Description of the Preferred Embodiment of the Invention

By way of introduction, the operation of a heart will be
5 discussed before describing the system embodying the present
invention. In Figure 1, the normal circulatory pattern of blood
through heart 10 is illustrated. Blood from the venous system
enters the first chamber of the heart, the right atrium (R.A.)
12. From right atrium 12, it passes through tricuspid valve 14
10 into right ventricle (R.V.) 16 via pulmonic valve 18, entering
pulmonary artery 20 which leads to lungs 22. In lungs 22, carbon
dioxide is released and the blood is reoxygenated. Blood then
exits lungs 22 back into pulmonary vein 24 which leads to left
atrium (L.A.) 26. From left atrium 26, blood passes through
15 mitral valve 28 into left ventricle (L.V.) 30. Blood then exits
heart 10 via aortic valve 32 into aorta 34 and the generalized
arterial circulation.

Cardiac contraction is orchestrated by electrical impulses
originating from the heart's nervous system. Electrical
20 stimulation to the myocardial fibers results in muscular
contraction. Specifically timed electrical signals originating in
the upper chambers of the heart cause the atriae to contract and
empty blood into the ventricles 16 and 30. After atrial
contraction, a short electrical delay takes place. This pause
25 allows the ventricles 16 and 30 to receive blood from atriae
before they are stimulated to contract. With ventricular

contraction, blood is ejected from heart 10.

Figure 2A-2E illustrate a simplified diagram of normal cardiac contraction as visualized from left ventricle 30. The cardiac cycle can be broken down into two major stages: diastolic and systolic. Diastolic is the relaxation phase of the ventricular contraction cycle. During this time the ventricle relaxes and fills up with blood in preparation for the next contraction. Systole is the ventricular phase involved with contraction and the process of ejecting blood from the heart.

Figure 2A illustrates the first phase of diastole which is isovolumetric relaxation immediately following a systolic contraction. This represents the transition phase between diastole and systole.

Figure 2B illustrates that with further ventricular relaxation, a building of negative pressure within the ventricle due to dilation results in a rapid influx of blood. Additionally, the geometric angle formed between the ventricular wall, papillar muscle (P.M.) 36, chordac tendinea (C.T.) 38 and mitral valve (M.V.) 28 widens. This combined process results in the opening of mitral valve 28.

Figure 2C illustrates the latter stages of diastolic ventricular filling. During this phase, left atrium 26 contracts to allow for maximal ventricular filling.

In Figure 2D, left ventricle 30 begins to build muscular tension prior to actually contracting and secondarily reducing ventricular volume. This phase demonstrates isovolumetric

contraction and is referred to as pre-systole. With building
ventricular contraction, the intraventricular pressure increases
which helps force mitral valve 28 closed. Additionally, the
geometric relationship between the valve cusp and muscle-tendon
5 supporting structures narrows with ventricular contraction which
assists in mitral valve closure.

Figure 2E illustrates that as ventricular contraction
progresses, the intraventricular volume decreases and pressure
builds. Once the ventricular pressure exceeds the blood pressure
10 within aorta 34, aortic valve (A.V.) 32 is pushed open. Blood is
then ejected from the ventricular cavity into aorta 34. This
phase is called systole.

By way of further introduction, the retractor disclosed in
the parent disclosure will be briefly discussed. The retractor
15 disclosed in the parent disclosure clamped the heart in a manner
that restricts the length dimension while permitting the other
dimensions to change. By immobilizing the heart in a direction
along dimension L, but allowing the remainder of the heart to
operate in a normal manner, operation of the heart is not
20 restricted. The retractor of the present invention further
immobilizes only the specific surgery target area whereby the
remainder of the heart operates in an unrestricted manner. Thus,
only the specific surgery location is immobilized. This is all
that is required for a successful surgery and the entire heart
25 need not be immobilized. The system for manipulating a heart
during cardiac surgery of the present invention also lifts the

WO 99/60930

PCT/US99/11655

heart in a manner that permits unrestricted operation of the heart as well.

Since the present invention is an improvement over the parent disclosed invention US Patent No. 6,019,722, it will be instructive to briefly review that parent retractor. Further discussion of the parent retractor can be found in the parent disclosure which is incorporated herein by reference. Referring specifically to Figures 3-5, system for manipulating a heart during cardiac surgery 50 of the parent invention is shown in detail. The retractor permits regional and specific immobilization of the heart while permitting essentially unabated cardiac output whereby all coronary arteries, including the circumflex coronary artery, to be bypassed and the heart maintained in an unnatural position and/or orientation. The retractor includes a gross support means 52 for engaging an apex portion (gross weight) of a heart to support the heart when the heart is lifted for surgery. Support means 52 includes a cup-shaped portion 54 having a top rim 56 and an apex 58 with ribs 60 defined adjacent to the apex to support the heart in the cup-shaped element. While a cup-shaped element is preferred, one could substitute other attachment configurations without departing from the scope of this disclosure. The only requirement is that the element be sized and shaped to adequately support the heart to achieve the results discussed herein, to wit: supporting the heart in an orientation suitable for the type of heart surgery of interest here. Thus, no limitation as to specific shape is intended for



element 52. Vacuum ports 62 are defined through the cup-shaped element at apex 58 to be fluidically connected with a vacuum source for securing the heart in place in the cup-shaped element. A vacuum source V is fluidically connected to holes 62 via main support arm 64 which has one end thereof fixed to a stationary support S (see Figure 5), such as the operating table, or a rib spreader, and the other end thereof attached to the cup-shaped element via fastener 66 attached to anchor 68. A manifold-like portion 70 of the cup-shaped element distributes the vacuum to the various ports, such as ports 62 to be applied to secure retractor 50 to the heart. An alternative form of the retractor includes a separate hose 72 to transfer vacuum to the manifold 70. Ribs 60 keep heart fat from clogging the vacuum manifold section.

The retractor of the parent disclosure further includes a fine support means for immobilizing selected portions of the heart while permitting non-immobilized portions to move in a manner that continues heart operation. This fine support means includes a plurality of rigid arms 80 each being fixed at one end thereof to anchor 68 and having a heart-attaching element 82 thereon, such as at the outer end thereof. As used herein, the term "rigid" is a relative term and means that the arms are rigid enough whereby the force of the heart won't move them. But they can be adjustable such as being formed of a wire-wound gooseneck or soft metal which allows each arm to be individually shaped according to the needs of the attachment location. The heart-

attaching elements can be suction attachment points, such as suction cups that are fluidically connected to manifold 70. Other means of attaching the elements to the heart, can be used as well without departing from the scope of the present disclosure as will occur to those skilled in the art based on the teaching of this disclosure. Examples of other such elements include glue, sutures, clamps, shallow pins, pincers or the like, with attachment points being located on the arm as suitable. The rigid arms secure small or fine areas of the heart in place with respect to gross element 52 while permitting the heart to move as required to continue unabated cardiac output. Support means 50 further includes a plurality of flexible support arms 84 each fixed at one end thereof to anchor 68 and having a heart-attaching element 86 on the outer end thereof. Elements 86 can be suction elements similar to the just-discussed elements 82. Flexible arms 84 can be adjusted to secure the heart in the most advantageous locations whereby the heart can continue to operate without undue restriction.

Therefore, broadly, the overall parent retractor comprises a main support which includes the arms, the hub and a stationary member, such as a table top, the floor or the like; a gross support which includes the apex cup and fine support means which regionally immobilizes portions of the heart while leaving other regions of the heart free to operate in an unabated manner to maintain heart output during the surgical procedure. The fine support means can include the rigid arms as well as the surgery

target immobilizing means. In this manner, the heart is supported regionally yet operates to maintain blood flow during coronary surgery.

Referring to Figure 5, it can be seen that parent retractor
5 10 includes a surgery target-immobilizing element 100 for immobilizing that exact location of the heart on which surgery is being performed. Element 100 includes a rigid arm 102 fixed at one end 104 to connecting arm 106 of stationary main arm 64 and having a U-shaped target-defining element 108 on the other end.
10 Element 108 includes two legs 110 and 112 connected by a central section 114. As shown in Figure 5, the target vein 116 being incised at 118 is located between legs 110 and 112. Element 108 is rigid as is arm 102 so target area 118 will be immobile even though the remainder of the heart adjacent to this area will be
15 moving. However, only a small section of the heart will be immobilized and thus should not affect the overall operation of the heart during the operation. The target-immobilizing element can be moved anywhere it is needed by simply loosening clamp 120 and moving arm 102 as necessary.

20 As was discussed in the parent disclosure, during operation of the heart, the left ventricle is a conical shaped cavity narrowest at the apex. It shortens both in length and in diameter during a pumping stroke (contraction). Since the volume of blood displaced is more dependent on the reduction in diameter (square)
25 than the shortening in length (first power), any measure which reduces the diameter of shortening is very detrimental. Also, the



right ventricle is attached to the left ventricle and is considerably thinner and less powerful. Suction attachments to this part of the heart which would impede the shortening of muscle may be poorly tolerated. The invention disclosed and taught herein uses a series of linked attachments to the heart. Attachments which are near the artery to be bypassed are paired on opposite sides of the artery and do not move - they immobilize the artery and therefore the muscle in the target region. A lifting suction is applied at the apex of the heart. If this were the only site of lifting, the heart would be stretched and there would be no diameter left. Thus, no blood could be ejected. However, this invention adds additional heart attaching elements that are attached to the heart to lift it. These attachment points would be mobile in that they could allow the heart to move inward and reduce the diameter and eject blood. The key to the invention is the linking of lifting (both at the apex and around the circumference of the heart) and regional immobilization which stops one part around the circumference from moving and therefore allows easy suturing.

As discussed above, while the parent retractor works well, it can be improved. Referring to Figures 6A-28, a system for manipulating a heart during cardiac surgery is shown which has improved operation over the parent retractor.

The heart manipulation system of the present invention utilizes a special suction cup to attach various elements thereof to the beating heart in a manner that permits the heart and the

myocardium to move during heart operation without unduly affecting the attachment of the element to the heart.

Specifically, the suction cup of the present invention applies suction to the heart surface from a source of suction (not shown,

5 but discussed in the parent disclosure). Suction cup 200 of the present invention is best shown in Figure 7A which shows a suction cup that is most useful with non-flaccid tissue in which it is easier to make the suction cup conform to the tissue than to force the tissue to conform to the suction cup, and Figure 7B

10 which shows a suction cup that is most useful with flaccid tissue which is easier to force to conform to the shape of the suction cup. Both suction cups 200 can be compared to a prior art suction cup SC shown in Figures 6A and 6B. As shown in Figures 6A and 6B,

15 prior art suction cup SC includes a single chamber C that is fluidically connected to a suction line L and which has a rim R for engaging the surface, such as tissue T, to which suction cup SC is attached. Suction pressure is applied over an area A which corresponds to the area of the suction line L. As will be

20 understood by those skilled in the art, if tissue T moves it can move away from rim R thereby breaking the suction being applied to tissue T. Still further, if tissue T moves, it might move into suction line L thereby interfering with application of suction to the tissue, as is indicated in Figure 6B. This latter situation

25 is likely since the maximum suction force is applied over area A and will tend to distort tissue T in the manner indicated in Figure 6B. Such distortion also tends to move the tissue away



from rim R.

However, suction cup 200 shown in Figures 7A and 7B does not have these drawbacks because it includes a plurality of chambers and a means for preventing tissue from interfering with suction
5 being applied thereto. Specifically, suction cup 200 is a multi-section suction cup which includes a first chamber 202 having a flexible rim 204 for engaging the tissue M of a heart, a second chamber 206 for fluidically connecting first chamber 202 the source of suction via suction line 208. Second chamber 206 of the
10 suction cup has a size that is different from the size of first chamber 202, and a shoulder 209 is formed at the connection between first and second chambers 202 and 206. A mesh grid element 210 is connected to the suction cup, preferably adjacent to shoulder 209, and spans second chamber 206. Flexible rim 204 is
15 flexible in a plurality of planes to accommodate multiplanar movement of the surface of the beating heart without breaking contact between the surface of the heart and flexible rim 204.

As can be understood from Figures 7A and 7B, suction cup 200 will not break suction with tissue T even if the tissue is drawn
20 into the suction cup and a large area of applied suction is maintained due to the large area A' of second chamber 206 vis à vis area A of suction cup SC. Thus, suction cup 200 is able to adapt to movement of the heart and movement of the myocardium while maintaining a large suction force on the tissue. This permits
25 smaller amounts of myocardium to be affected by the system of the present invention than even the parent retractor. Since chamber



202 is large, rim 204 can be large and thus its flexibility can be increased over rim R of suction cup S. This permits rim 204 of suction cup 200 to follow movement of tissue T far better than rim R of suction cup S.

5 Suction cup 200 is the best mode used in the present invention; however, other forms of suction cups can be used without departing from the scope of the present invention and disclosure. The other forms of the suction cup will also have at least one first chamber and one second chamber and a flexible rim
10 as well as a mesh grid element preventing tissue from interfering with suction applied via the suction cup. Other forms of the suction cup are indicated in Figures 17 and 18A through 22B, with Figure 17 showing a multiplicity of chambers and a multiplicity of shoulders; Figures 18A and 18B showing an off center chamber
15 202'; Figures 19A and 19B showing a plurality of suction lines 208' and 208''; Figures 20A and 20B showing a reinforcing ring RR surrounding suction line 208'''; Figures 21A and 21B showing a ring RR' around a plurality of suction lines; and Figures 22A and 22B showing a suction cup 200K having a kidney-shaped
20 perimeter. One or more suction lines can be associated with cup 200K as is indicated in Figure 22A. Suction cup 200 has walls 200W and 200W1 that are oriented at a sharper angle with respect to base 200B of the suction cup than are the wall W of suction
25 cup S. This permits the walls of cup 200 to be more flexible than the walls of cup S.

Mesh grid element 210 functions to preserve suction pressure

on the tissue even if the tissue is drawn into the suction cup. Thus, mesh grid element 210 has a first portion that can be engaged by the tissue, and a second portion that will remain open even when the first portion is engaged by tissue. An example of such a mesh grid element is shown in Figure 15 as including a first portion 212 and a second portion 214 that are arranged orthogonally with respect to each other. Thus, even if tissue engages portion 212, that tissue will be spaced from portion 214 and a fluid passage will remain open between the tissue and the source of suction thereby maintaining suction force on the tissue. Other forms of the mesh grid element can be envisioned by those skilled in the art based on the teaching of this disclosure, and such other forms are also intended to be encompassed by this disclosure.

As will be evident to those skilled in the art based on the teaching of the present disclosure, this flexible rim multi-chamber suction element with a mesh grid element will be used in those elements of the heart manipulation system of the present invention that engage the heart to apply force to the heart to move and manipulate that heart during cardiac surgery.

A heart manipulation system 300 for use in cardiac surgery is broadly shown in Figure 8 as comprising a frame 302 that, as indicated in Figure 11, is located within the patient's thoracic cavity during beating heart surgery and which includes means for engaging the pericardial cavity of the patient for mounting said frame on the patient to move with the patient if the patient is

moved or re-oriented during surgery.

Frame 302 includes a cross bar 303 that includes a multiplicity of teeth 303T thereon for a purpose that will be understood from the following disclosure. Frame 302 further includes means for

5 engaging the patient to support the frame in position in the patient. A preferred form of this means includes two sternal spacers 304 which set the depth of the frame into the chest cavity and keep the frame from twisting as the lungs inflate and which are connected on cross bar 303 by a ratchet-like mechanism

10 305 that has teeth which engage teeth 303T when the spacers are in the desired location. The frame is expanded inside the pericardial cavity with the cross bar. A handle 305H is operated to set the teeth of the mechanism 305 to teeth 303T. The frame can be either C-shaped or hoop shaped and can be secured to the

15 patient or to an outside stable support. Other anchor means can be used as will occur to those skilled in the art based on the teaching of the present disclosure, and these means are intended to be within the scope of this disclosure as well.

As was the case in the parent disclosure, a source of

20 suction is located outside the patient and is used to attach various elements to the patient's heart. Most often, a source of vacuum is from the operating room source which provides approximately 100 to 180 mm of Hg vacuum. The source of suction is not shown herein as those skilled in the art will understand

25 where such source is best located and what source is best suited to the particular application based on the teaching of the



present disclosure.

As shown in Figure 8, system 300 includes a suspension head mechanism 312 movably mounted on frame 300 for lifting the heart. Mechanism 312 includes a head 314 which engages the heart and which is shown in Figure 9 as being located near the apical region of the right ventricle to prevent collapse of the right ventricle during manipulation of the heart, as is also shown in Figure 9, suspension head 314 at least partially overlies the right ventricle. Suspension head mechanism 312 includes a flexible means 316, such as a spring, for connecting flexible head 314 to arm 318 and for permitting multiplanar relative movement between the beating heart and arm means 318 mounting suspension head 314 on frame means 302. Suspension head 314 includes a suction cup such as disclosed above in Figures 7A and 7B connected to the source of suction and which includes a flexible rim engaging the myocardium of the heart and being flexible in a plurality of planes so multiplanar movement of the myocardium during operation of the heart will be accommodated by the flexible rim whereby suction applied to the myocardium by the suction cup will not be broken by separation of the myocardium from the suction cup, As discussed above, the suction cup of head 314 includes means, such as the above-discussed mesh grid, for preventing heart tissue from interfering with suction being applied to the myocardium via head 314.

Arm 318 is flexible in one condition as discussed in the parent disclosure, and is made rigid by manipulation of control



and anchor element 324. Anchor element 324 includes a base 324 which is movably mounted on cross bar 303 and has internal teeth that engage teeth 303T, and a lever system for locking the internal teeth of element 324 to teeth 303T when desired. A

5 further lever-operated mechanism locks corresponding elements in arm 318 whereby arm 318 is rendered rigid. Arm 318 includes a flexible central line extending from head 314, through flexible element 316 to anchor element 324 and a plurality of relatively movable sections, such as balls 326 interposed between links 328,

10 on the central line. A lever 330 is connected to the central line and when the lever is operated, the elements 326 and 328 are forced together to render the arm rigid. In this manner, the suspension head 314 can be easily maneuvered on a flexible arm into the desired position and then locked into that position by

15 rendering arm 318 rigid. Flexible means 316 permits multiplanar movement of suspension head 314 even after arm 318 is made rigid whereby movement of a beating heart is accommodated by suspension head mechanism 312. When suction is applied to the heart via head 314 the heart will be suspended and can be lifted into the

20 desired position and orientation for cardiac surgery without interrupting cardiac output. The combination of the suction cup, the flexible/rigid arm, the flexible means and the location of the head on the heart effect this result. Various forms of head 314 can be used without departing from the scope of the present

25 invention, and a second form of the head is shown in Figure 17 as head 314' and which includes a multiplicity of chambers. Any of



the suction cup forms shown in Figures 16A-22B can also be used for head 314 if desired.

With the heart supported by suspension means 312, the cardiac surgery can be completed if desired. As will be discussed
5 below, however, additional support can be provided. Cardiac surgery was discussed above and in the parent disclosure, reference being made thereto for such discussions. As was discussed, a surgery target immobilizer is used to locally immobilize the heart while permitting the non-engaged portions of
10 the heart to continue to operate so as to maintain cardiac output essentially unabated. Shown in Figure 23 is a surgery target immobilizer SI discussed in the parent disclosure. Immobilizer SI includes two rigid sections, such as section SIR, each of which includes a plurality of suction cups 200 fluidically connected to
15 a source of suction via a line L to be attached to the heart with the surgical target immobilized for surgery.

The system of the present invention improves this by including a means 340 for locally engaging a selected section of the heart and locally immobilizing the heart adjacent to a
20 surgery target so the heart is supported by the suspension head mechanism and can receive further support from the surgery target immobilizing means and can thus be free to operate during surgery while it is also locally immobilized at the surgery target with non-engaged sections of the heart free to move in a manner
25 whereby essentially unabated cardiac output is maintained while the heart is locally immobilized. The surgery target immobilizing

means 340 of the present invention includes a flexible section 342, such as suction cup 200, on each rigid element SIR. The suction cups 200 attached to each rigid element function and operate as discussed above and shown in Figures 24 and 25 are
5 connected to the source of suction and each includes a flexible rim engaging the myocardium of the heart and being flexible in a plurality of planes so multiplanar movement of the myocardium during operation of the heart will be accommodated by the flexible rim of the surgery-target immobilizing means whereby
10 suction applied to the myocardium by the suction cup of the surgery target immobilizing means will not be broken by separation of the myocardium from the suction cup of the surgery target immobilizing means. As was discussed above, suction cups of the surgery target immobilizing means each include means for
15 preventing heart tissue from interfering with suction being applied to the myocardium via said suction cup of the surgery target immobilizing means.

As discussed above, in some circumstances, two point support is preferred when performing cardiac surgery. Accordingly,
20 manipulation system 300 of the present invention provides a gross support means 400 movably mounted on frame 300 for engaging the heart to support the heart when the heart is oriented for surgery and which is located at the base of the heart and which cradles the myocardium of the left ventricle along the arterialven-
25 tricular groove (AV). Gross support means 400 is shown in Figures 8, 9, 12, 13, and 14A-14C. As broadly shown in Figure 8, gross

support means 400 includes a head 402 that is engaged with the heart and which is movably connected to frame 300 by an arm mechanism 403 similar to arm 318 to be flexible and movable with respect to the heart and with respect to frame 300 when desired, and then rendered rigid by operation of a lever 404 of an anchor mechanism 406 that can be located on cross bar 303 or on one of the sternum retractors 304. Operation of the flexible arm 403 is identical to that of arm 318 and thus will not be again discussed.

Gross support means 400 supports the mitral valve annulus to maintain competent mitral valve function and head 402 is placed beneath an infolded section of myocardium. Gross support means 400 includes a handle 408 which is attached to head 402 and which extends outside of the patient during surgery for adjusting the location of gross support means head 402.

Head 402 is shown in Figures 12-14C as including a rigid support section 407 connected to a flexible section 488 having malleable rod means 410 received in bores 411 defined in head 402 for retaining a configuration that has been set for head 402 and for connecting head 402 to the arm 403 for mounting gross support means 400 on frame 302. Head 402 can include a plurality of sections which are movable relative to each other and means for maintaining those sections in a selected relative orientation. In this manner, head 402 can be shaped to best support the heart and can be adjusted to meet the needs of an individual heart. As head 314 is also adaptable to the size and shape of an individual



heart, the two-point support of system 300 can be adjusted and customized to fit the exact needs of each individual heart. The flexible and adjustable feature of head 402 is indicated in Figure 13.

5 As shown in Figures 14A-14C, head 402 includes means for applying suction from the source of suction to the heart. As best shown in Figure 14A, this means includes a mesh grid means 210 attached to head 402 and spanning a first chamber 420 above a suction applying manifold 422 that is fluidically connected to
10 the source of suction by suction line for preventing heart tissue from interfering with suction applied by suspension head 402 to the heart. A frame 424 maintains mesh grid means 210 in place on head 402, and ribs, such as rib 426 and rib 428 can be used to maintain the desired position of mesh grid element 210 with
15 respect to suction holes 208 at the end of the suction line.

Using the system 300, a method of performing heart surgery comprises steps of placing frame 300 in the patient, slightly infolding the left atrium of a heart adjacent to the base of the heart, engaging the heart under the edge of the myocardium at the
20 base of the heart with gross support means 400 then using handle 408 tilting and lifting the heart. The heart is engaged near the apex of the heart with suspension head 314 to lift the heart. Such engagement prevents right ventricle collapse. This provides two point support if desired. However, as discussed above, the
25 suspension means alone may be sufficient in some cases to move the heart as necessary. The method can further including a step

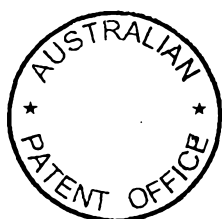

WO 99/60930

PCT/US99/11655

of using surgery target immobilizing means 340 shown in Figure 24 to apply suction to the heart adjacent to the selected surgical target for engaging that selected section of the heart and immobilizing that selected section as a surgery target while
5 permitting non-engaged sections of the heart to move and permitting essentially unabated cardiac output to be maintained while the heart is regionally immobilized.

Alternative forms of the frame 300 can be used without departing from the scope of the present disclosure, just so the
10 frame is located to move with the patient. Thus, a frame 302' shown in Figure 26 can be used. Frame 302' essentially completely surrounds the heart and includes elements 304' for engaging the patient to support frame 302' in place, a handle 302H can be used to adjust the location of frame 302'. Handle 302H includes a knob
15 302K which operates a pinion system for engaging teeth 303T to adjust the size of the frame circumference as indicated by arrow 302S in Figure 26.

Yet another form of the manipulation system of the present invention is shown in Figures 27 and 28. System 300'' includes a
20 gross support system 500 which extends around the heart near the base of the heart and which can include a plurality of suspension heads 314'' located at various locations on the heart, including near the apical region and which are connected to flexible/rigid arm 502 which corresponds in structure to arms 318 and 403
25 discussed above and which are mounted on the frame.

It is understood that while certain forms of the present



invention have been illustrated and described herein, it is not to be limited to the specific forms or arrangements of parts described and shown.

P:\WP7\DOCS\CRN\Patent\Spec\7558590.d\lms.doc-06/03/03

The claims defining the invention are as follows:

1. A heart positioning device for use in cardiac surgery on a beating heart, comprising: a suction head adapted to positively engage the beating heart; an arm which is flexible in an unlocked condition and rigid in a locked condition; and a spring suspension connecting said suction head to said arm.

10 2. The heart positioning device of claim 1, wherein said suction head is adapted to engage a heart near an apical region thereof, and said arm is adapted to be fixed to a relatively stationary object.

15 3. The heart positioning device of claim 2, wherein said spring suspension permits movement of the heart in at least one plane when said suction head is engaged with the heart, said arm is fixed to the relatively stationary object, and said arm is in said locked condition.

20

4. The heart positioning device of claim 3, wherein said spring suspension permits multiplanar movement of the heart when said suction head is engaged with the heart, said arm is fixed to the relatively stationary object, and said arm is in said locked condition.

25

5. The heart positioning device of any one of claims 1 to 4, wherein said suction head comprises a vacuum input adapted to fluidically connect with a source of vacuum.



P:\WPDOCS\CRM\Amia\Spec\7558590.d\ainu.doc-06/03/03

6. The heart positioning device of any one of claims 1 to 5, wherein said suction head comprises a flexible rim adapted to engage the heart.

5 7. The heart positioning device of any one of claims 1 to 6, wherein said suction head comprises a flexible suction cup.

8. A heart manipulation system for use in cardiac
10 surgery, comprising: a sternal retractor;

a suction head adapted to engage an apical region of the heart;

an arm which is flexible in an unlocked condition and rigid in a locked condition;

15 a suspension mechanism connecting said suction head to said arm; and an attachment mechanism adapted to fix said arm to said sternal retractor; wherein said suction head is free to move, relative to said arm via said suspension mechanism, even when said arm is in said locked condition.

20

9. The system of claim 8, wherein said suspension mechanism is biased upon engaging the heart with said suction head and lifting the heart with said arm through said suction head.

25

10. The system of claim 8, wherein said suspension mechanism comprises a spring.

11. The system of any one of claims 8 to 10, wherein said arm comprises a series of balls and links interconnected by a flexible line passing therethrough.

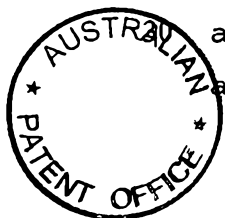

P:\WPDOCS\CRN\Parita\Spec\7558590.claims.doc-06/03/03

12. A heart positioning device adapted to suspend a heart from an apical region of the heart, for use in cardiac surgery, said device comprising a cup shaped head adapted to engage the heart and being suspended from an arm which is
5 flexible in an unlocked condition and rigid in a locked condition.

13. The device of claim 12, further comprising a mechanism adapted to fix said arm to a relatively stationary
10 object.

14. The device of claim 13, wherein said mechanism is adapted to fix said arm to a sternal retractor.

15 15. The device of any one of claims 12 to 14 wherein said cup shaped head is freely moveable with respect to said arm even when said arm is in said locked condition.

16. The device of any one of claims 12 to 15, wherein
20 said cup shaped head, when engaging the heart, permits the heart to move relative to said arm even when said arm is in said locked condition, thereby preventing said device from causing any reduction in cardiac output of the heart when the heart is suspended by said device.

25

17. A retractor for use in heart surgery comprising:
a rigid gross support means for engaging a heart to support the heart when the heart is oriented for surgery and including a multipositional support element fixed to a stationary support;



P:\WPDOCS\CRNP\Pubia\Spec\7558590.claim.doc-06/03/03

means for immobilizing selected portions of the heart while permitting non-immobilized portions to move in a manner that continues heart operation; and

a surgery target immobilizing means connected to said support element and engaging the heart adjacent to a surgery target for immobilizing the heart at and immediately adjacent to the surgery target

whereby the heart is supported and free to operate during surgery while being locally immobilized at the surgery target.

18. The heart retractor defined in claim 17 wherein said gross support means includes a cup-shaped element for engaging and supporting the heart adjacent to the apex section of the heart.

19. The heart retractor defined in claim 18 wherein said support means further includes a plurality of rigid support arms each connected at one end thereof to said stationary support element and having a heart-attaching element thereon.

20. The heart retractor defined in claim 19 wherein said each heart-attaching element includes a suction attachment point.

21. The heart retractor defined in claim 19 wherein said support means further includes a vacuum source and means fluidically connecting said vacuum source to said cup-shaped element and further including means fluidically connecting said vacuum source to each heart-attaching element.



P:\WPDOCS\CRN\Punita\Spec\7558590.claima.doc-06/03/03

22. The heart retractor defined in claim 18 wherein said support means further includes a vacuum source and means fluidically connecting said vacuum source to said cup-shaped element.

5

23. The heart retractor defined in any one of claims 17 to 22 wherein said target-immobilizing element includes a U-shaped target-defining element having two legs and means thereon for engaging the heart to position one leg on each
10 side of the surgery target.

24. The heart retractor defined in claim 23 wherein said target-immobilizing element further includes a rigid arm attached to said U-shaped element and to said stationary
15 support element.

25. The heart retractor defined in any one of claims 17 to 24 wherein said means for immobilizing selected portions of the heart includes attachment means thereon for attaching
20 to the surface of the heart.

26. A heart retractor for use in heart surgery comprising:

support means for supporting the gross weight of a
25 heart to support the heart when the heart is oriented for surgery and including a main support arm having means at one end thereof for mounting the support arm on a stationary support; and

means for immobilizing selected portions of the heart and
30 permitting other sections to move as required to continue heart operation during surgery, said immobilizing means including at least one rigid support arm connected at one



P:\WPDOCS\CRNP\Patia\Spec\7558390.claims.doc-06/03/03

end thereof to said support means and having means thereon
for releasably attaching said rigid support arm to the
heart, and at least one flexible support arm connected at
one end thereof to said support means and having means on
5 another end thereof for releasably attaching said flexible
support arm to the heart.

27. The heart retractor defined in claim 26 wherein said
means for immobilizing selected portions of the heart
10 includes a plurality of flexible arms each connected at one
end thereof to said support means and each having a heart-
engaging member thereon.

28. The heart retractor defined in claim 27 wherein each
15 heart-engaging member is a suction attachment point.

29. The heart retractor defined in claim 26 further
including a surgery target immobilizing element having one
end thereof connected to said support means and heart-
20 engaging elements on another end thereof.

30. A retractor for use in minimally invasive heart
surgery comprising: support means for engaging a heart to
support the heart when the heart is oriented for surgery and
25 including a handle having a distal end and a proximal end,
said proximal end being located outside of a patient during
surgery, a support element fixed to said distal end, and
rigid elements fixed to said distal end and engaging and
supporting chosen sections of the heart; and

means for immobilizing selected portions of the heart
while permitting non-immobilized portions to move in a
manner that continues heart operation



P:\WPDOCS\CRNP\Patent\Speci7518590.claims.doc-06/03/03

whereby the heart is supported and free to operate during minimally invasive surgery while being immobilized at selected locations.

5 31. The retractor defined in claim 30 wherein said means for immobilizing selected portions of the heart includes a plurality of flexible arms each connected to said handle.

32. The retractor defined in claim 30 or 31 wherein each
10 rigid element includes a heart-engaging element and further includes a vacuum source fluidically connected to each heart-engaging element.

33. The retractor defined in any one of claims 30 to 32
15 wherein said support means includes a cup-shaped element fixed to the distal end of said handle.

34. The retractor defined in claim 33 further including a
vacuum source fluidically connected to said cup-shaped
20 element.

35. A retractor for use in heart surgery comprising:
support means for engaging a heart to support the heart
when the heart is oriented for surgery and including a
25 support element fixed to a stationary support and rigid elements engaging and supporting chosen sections of the heart;

means for immobilizing selected portions of the heart while permitting non-immobilized portions to move in a manner that continues heart operation



P:\WPDOS\CRM\Amia\Spec\7558590.claims.doc-06/03/03

whereby the heart is supported and free to operate during surgery while being locally immobilized at the surgery target.

5 36. A heart positioning device for use in cardiac surgery comprising: support means for engaging a heart to support the heart when the heart has been oriented into an unnatural position or orientation for coronary surgery;

means for attaching said support means to the heart so
10 the heart operates with uncompromised ventricular function when the heart is oriented into an unnatural position or orientation for coronary surgery:

means engaging sections of the heart to immobilize the sections engaged while permitting non-engaged sections of
15 the heart to move in a manner whereby essentially unabated cardiac output is maintained during surgery while the heart is regionally immobilized.

20 37. The heart retractor defined in claim 36 wherein said support means includes a means for engaging the heart sufficiently to support the heart during coronary surgery.

25 38. The heart retractor defined in claim 36 or 37 wherein said support means includes arms which have locking elements for permitting the arms to be moved into position and then locked in position.

30 39. The heart retractor defined in any one of claims 36 to 38 further including a surgery target immobilizing element connected to said support means and engaging the heart adjacent to a surgery target for immobilizing the heart at and immediately adjacent to the surgery target.



P:\WPDOCS\CRM\Punita\Spec\7558590.claims.doc-06/03/03

40. A heart retractor for use in heart surgery comprising:

support means for engaging an apex portion of a heart to support the heart when the heart is lifted for surgery and
5 including a main support arm having means at one end thereof for mounting the support arm on a stationary support; and

means for immobilizing selected portions of the heart and permitting other sections to move as required to continue heart operation during surgery, said immobilizing means
10 including at least one rigid support arm connected at one end thereof to said support means and having means on another end thereof for releasably attaching said rigid support arm to the heart, at least one flexible support arm connected at one end thereof to said support means and
15 having means thereon for releasably attaching said flexible support art to the heart.

41. The heart retractor defined in claim 40 further including a surgery target immobilizing element having one
20 end thereof connected to said support means and heart-engaging elements thereon.

42. A retractor for use in heart surgery comprising: a main support;

25 a gross support means for engaging a heart and supporting the heart when the heart is oriented for surgery, said gross support means being attached to said main support;

a fine support means for supporting portions of the heart during surgery, said fine support means being attached to said gross support means with non-supported portions of the heart moving in a manner whereby essentially unabated cardiac output is maintained during surgery while the heart



P:\WPDOCS\CRNP\Patent\Spec\7558590.claims.doc-06/03/03

is regionally immobilized at supported portions and including rigid elements engaging and supporting chosen sections of the heart.

5 43. A retractor for use in heart surgery comprising: a main support;

a gross support means for engaging a heart and supporting the heart when the heart is oriented for surgery, said gross support means being attached to said main

10 support and including means for adjusting the shape of said gross support means;

a fine support means for supporting portions of the heart during surgery, said fine support means being attached to said gross support means with non-supported portions of the
15 heart moving in a manner whereby essentially unabated cardiac output is maintained during surgery while the heart is regionally immobilized at supported portions and including rigid elements engaging and supporting chosen sections of the heart.

20

44. The retractor defined in claim 43 wherein said means for adjusting the shape of said gross support means includes a fastener attaching two arms together, with said two arms engaging the heart to support the gross weight of the heart.

25

45. The retractor defined in claim 43 or 44 further including attachment means on said fine support means for contacting the heart.

30

46. The retractor defined in claim 45 wherein said attachment means include suction points.



P:\WPDOCS\CRN\Patent\Spec\7558590.claims.doc-06/03/03

47. The retractor defined in any one of claims 43 to 46 further including a support arm and a surgery target immobilizing element attached to said support arm.

5 48. A heart positioning device for use in cardiac surgery comprising: a stationary support;

a rigid arm connected to said stationary support; a flexible element connected to said rigid arm;

means on said flexible element for releasably attaching
10 said flexible element to a heart to orient the heart into an unnatural position or orientation for coronary surgery and so the heart operates with uncompromised ventricular function when oriented into the unnatural position or orientation during coronary surgery.

15

49. The heart positioning device defined in claim 48 further including a second flexible element connected to said rigid arm.

20 50. The heart positioning device defined in claim 48 or 49 wherein said rigid arm is multipositional.

51. A heart positioning device for use in cardiac surgery comprising:

25 a stationary support for orienting the heart into an unnatural position or orientation for coronary surgery;

a flexible element connected to said stationary support for supporting the heart in a manner so the heart operates with uncompromised ventricular function when the heart is oriented into the unnatural position during coronary surgery; and



P:\WPDOCS\CRN\Patita\Spec\7558590.claim.doc-06/03/03

means on said flexible element for releasably attaching said flexible element to the heart.

52. A heart positioning device for use in cardiac surgery
5 comprising:

a stationary support for orienting the heart into an unnatural position or orientation for coronary surgery;

a rigid arm connected to said stationary support;

a flexible element connected to said stationary support;

10 means on said flexible element for releasably attaching said flexible element to a heart in a manner so the heart operates with uncompromised ventricular function when the heart is oriented into the unnatural position during coronary surgery.

15

53. The heart positioning device defined in claim 52 further including a second flexible element connected to said rigid arm.

20 54. The heart positioning device defined in claim 52 or 53 wherein said stationary support is multipositional.

55. A heart positioning device for use in cardiac surgery comprising: a frame;

25 a stationary support attached to said frame for orienting the heart into an unnatural position or orientation for coronary surgery;

a flexible element connected to said stationary support for supporting the heart in a manner so the heart operates
30 with uncompromised ventricular function when the heart is



P:\WPOCS\CRN\Funite\Spec\7551590.claim.doc-06/03/03

oriented into the unnatural position during coronary surgery; and

means on said flexible element for releasably attaching said flexible element to the heart.

5

56. The heart positioning device defined in claim 55 further including a second flexible element connected to said stationary support.

10 57. A heart positioning device for use in cardiac surgery comprising: a stationary support;

a flexible element connected to said stationary support for supporting a heart in a manner so the heart operates with uncompromised ventricular function when the heart is
15 oriented into an unnatural position or orientation during coronary surgery; and

means on said flexible element for releasably attaching said flexible element to the heart.

20 58. The device defined in claim 57 wherein said stationary support is multipositional for allowing the stationary support to move in a plurality of orientations and positions.

25 DATED this 6th day of March, 2003

GUIDANT CORPORATION

By its Patent Attorneys

DAVIES COLLISON CAVE



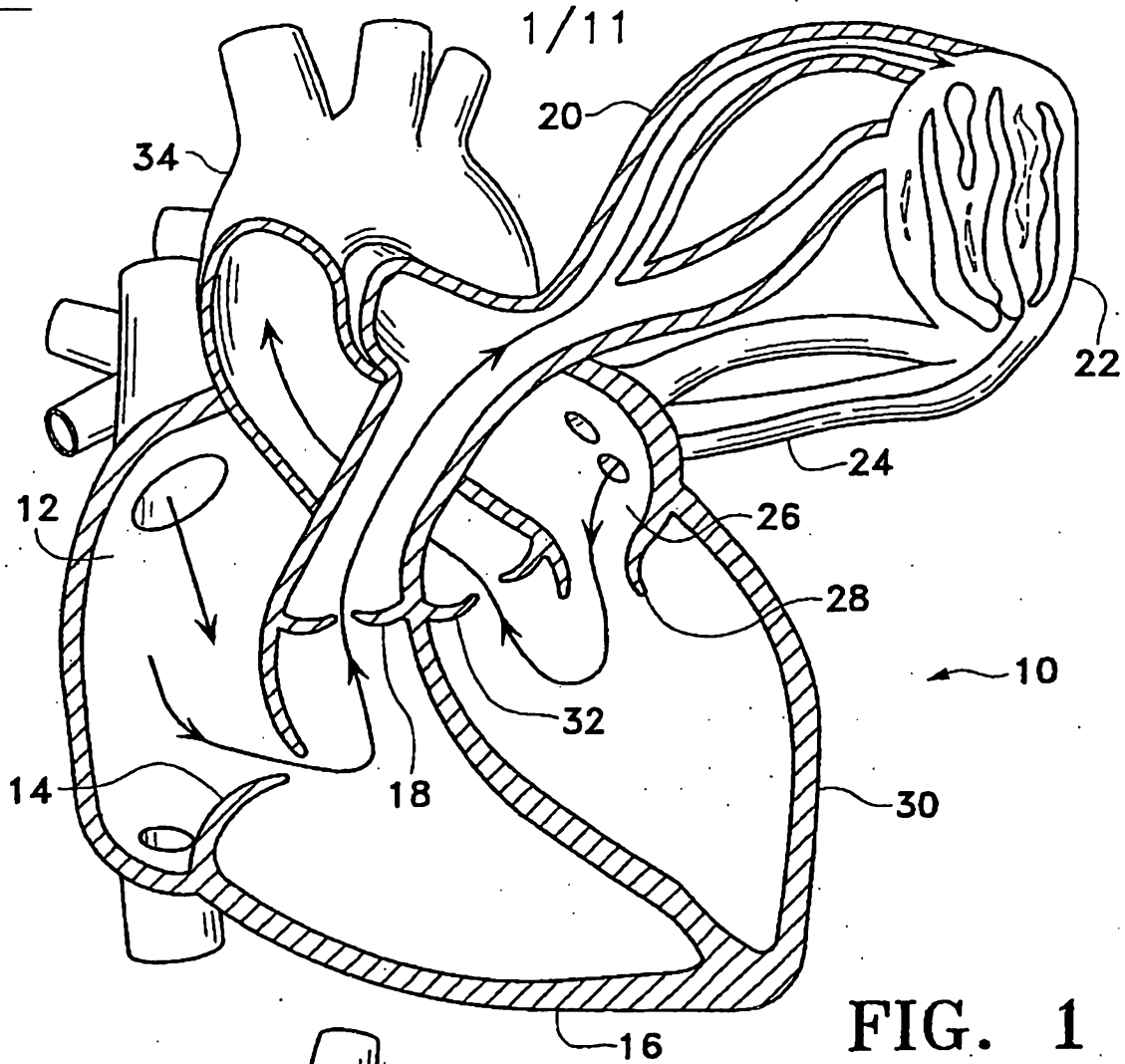

FIG. 1

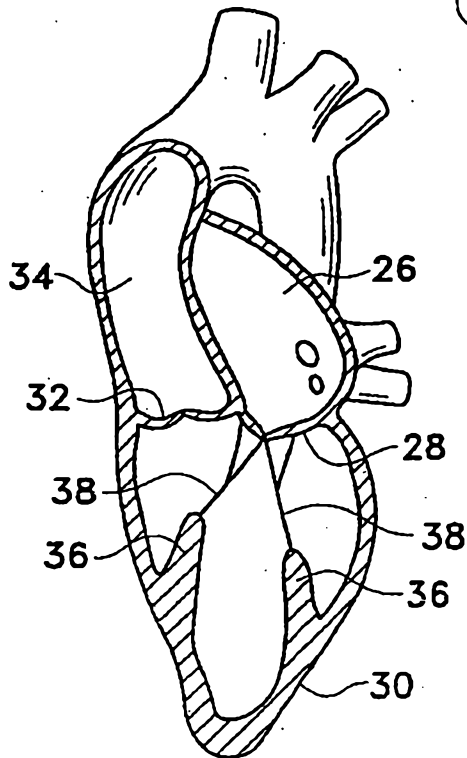

FIG. 2A

2/11

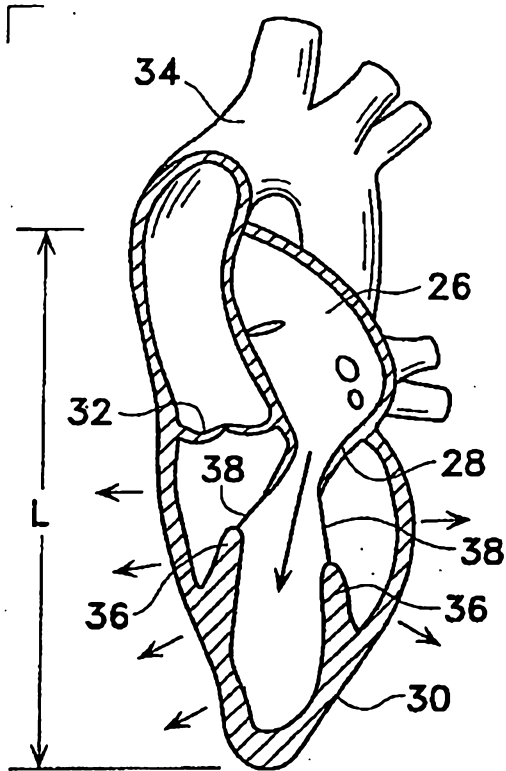

FIG. 2B

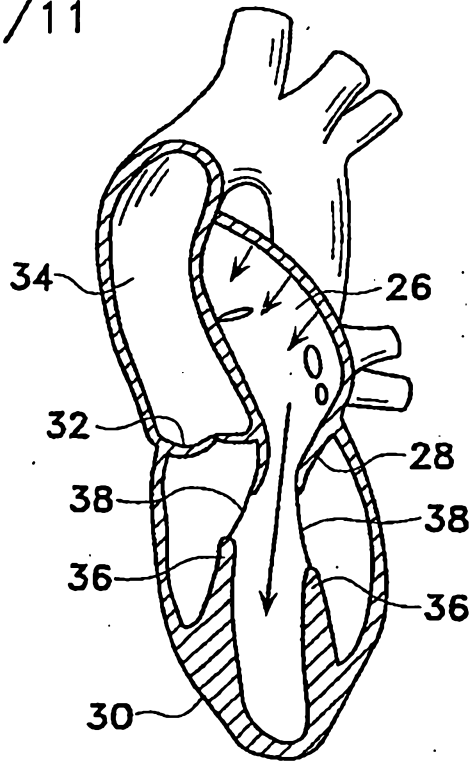

FIG. 2C

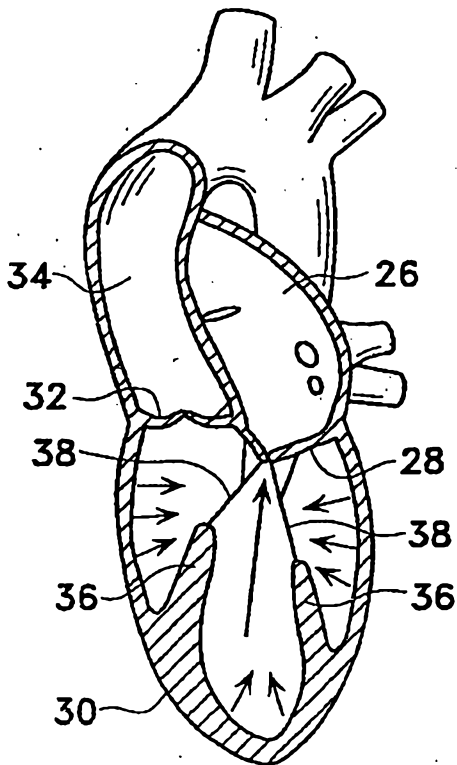

FIG. 2D

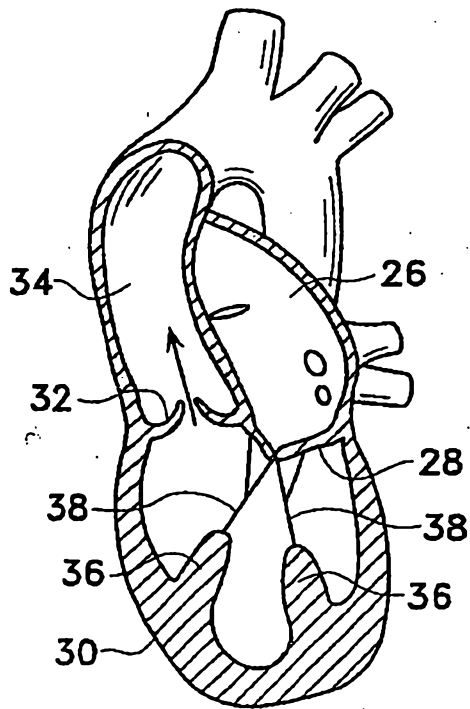

FIG. 2E

3/11

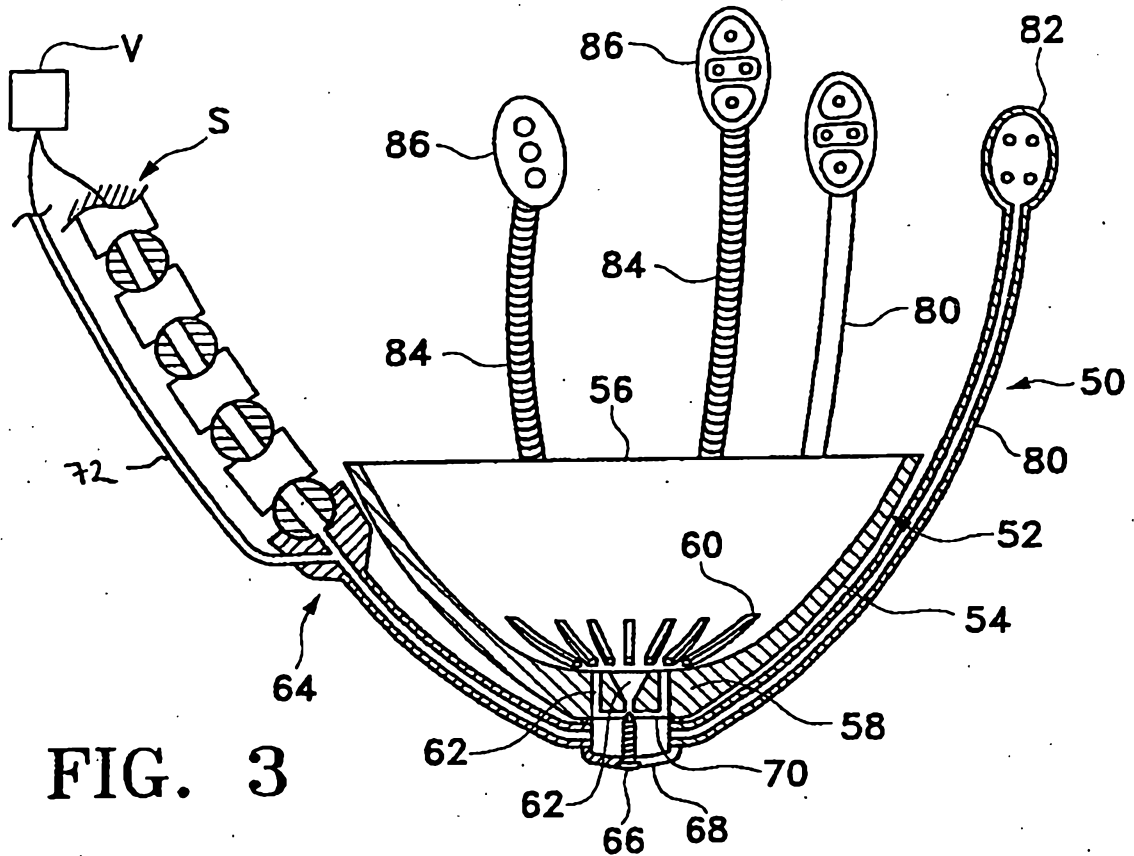

FIG. 3

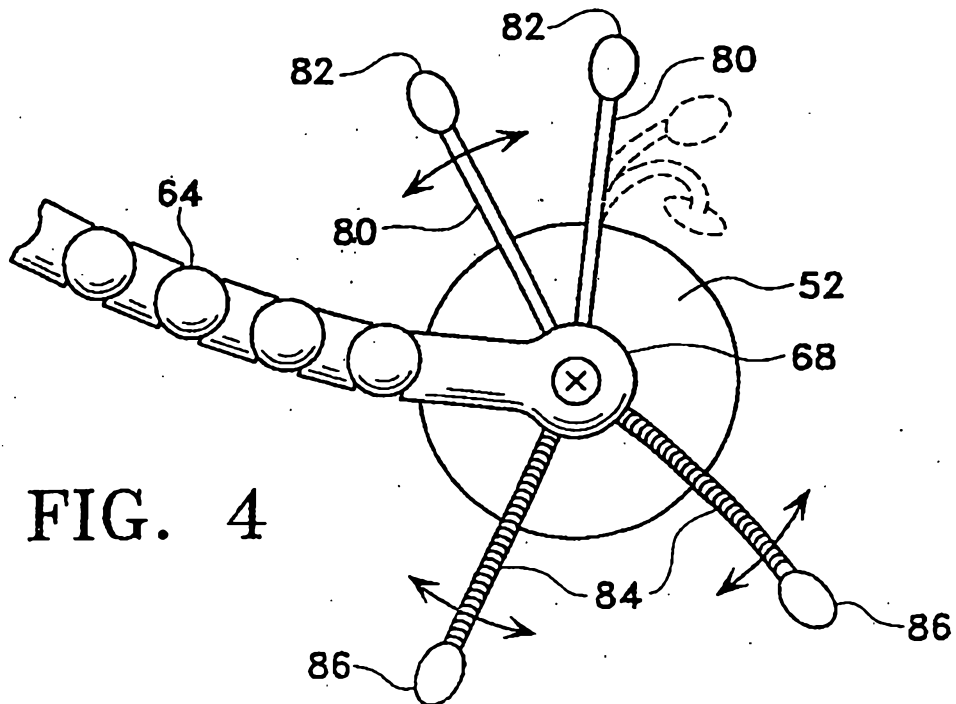
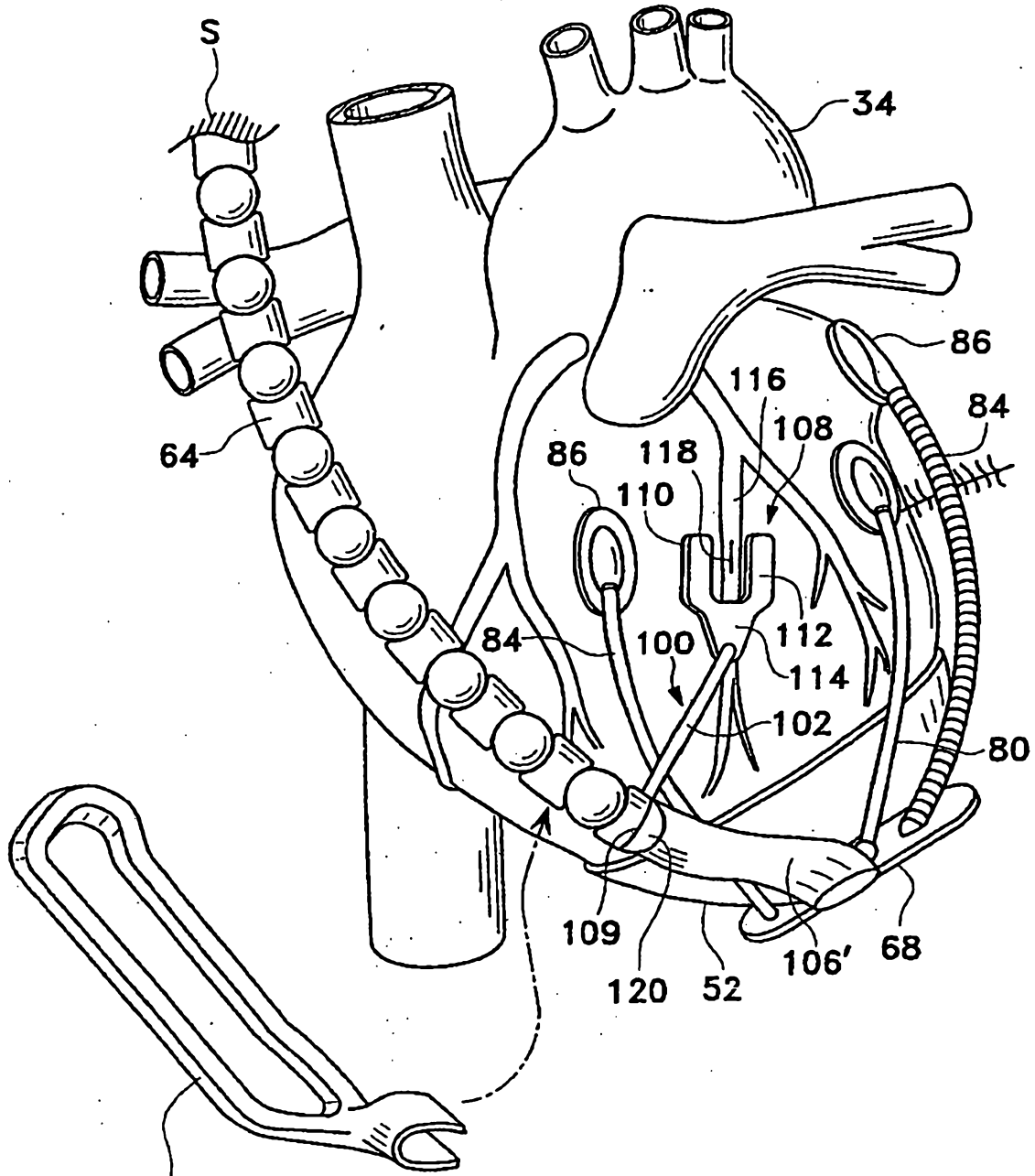

FIG. 4

4/11



Detachable Positionary Handle

FIG. 5

5/11

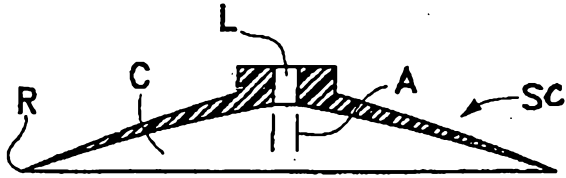

FIG. 6A
(PRIOR ART)

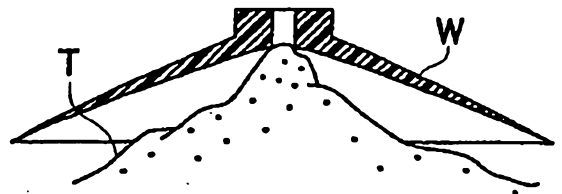

FIG. 6B
(PRIOR ART)

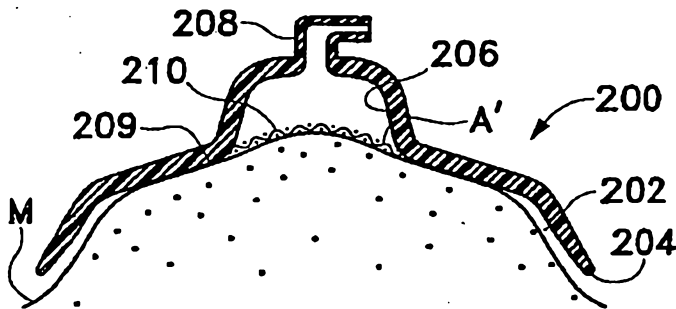

FIG. 7A

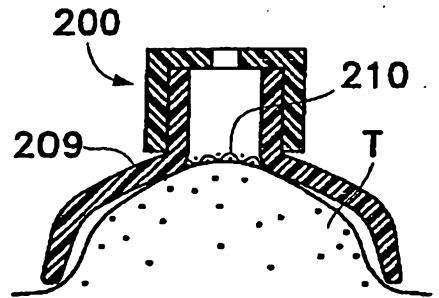

FIG. 7B

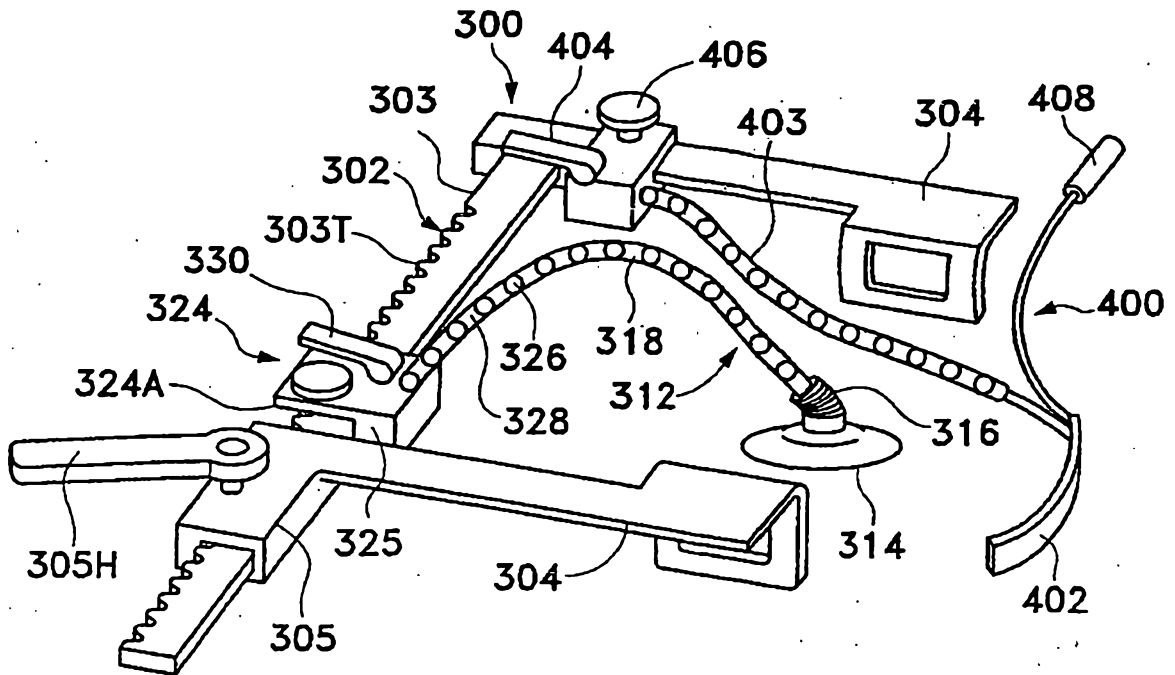

FIG. 8

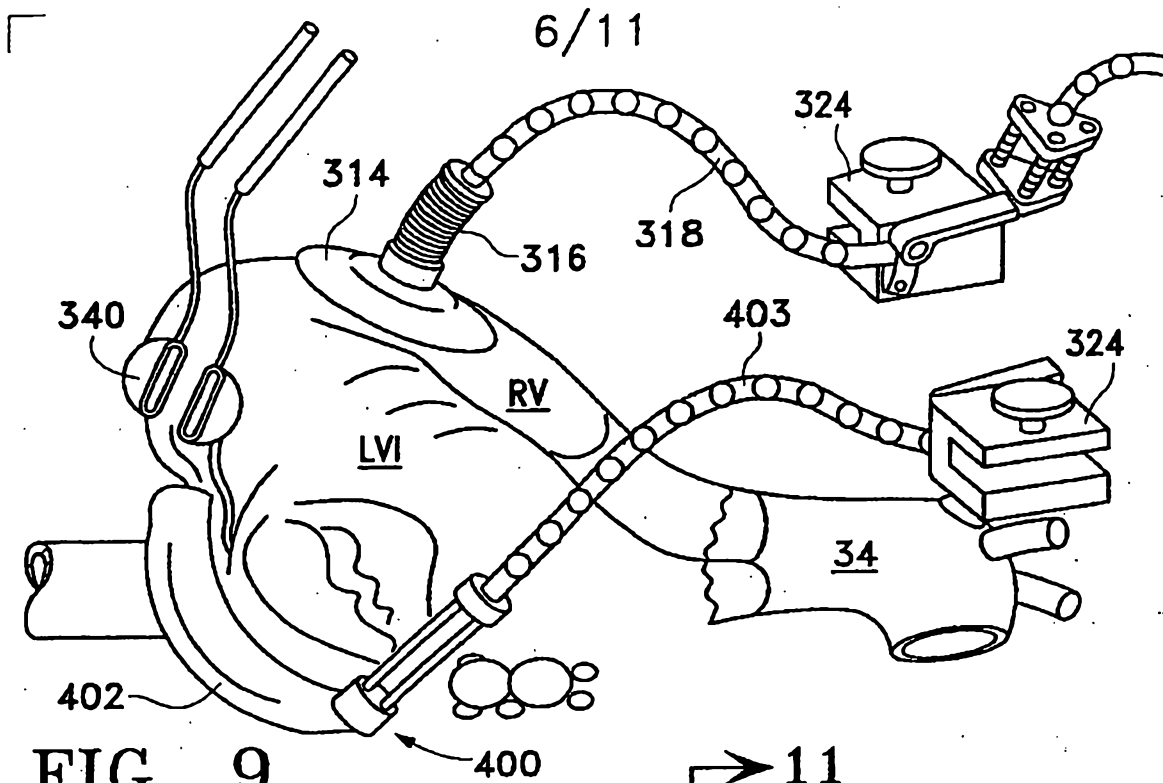

FIG. 9

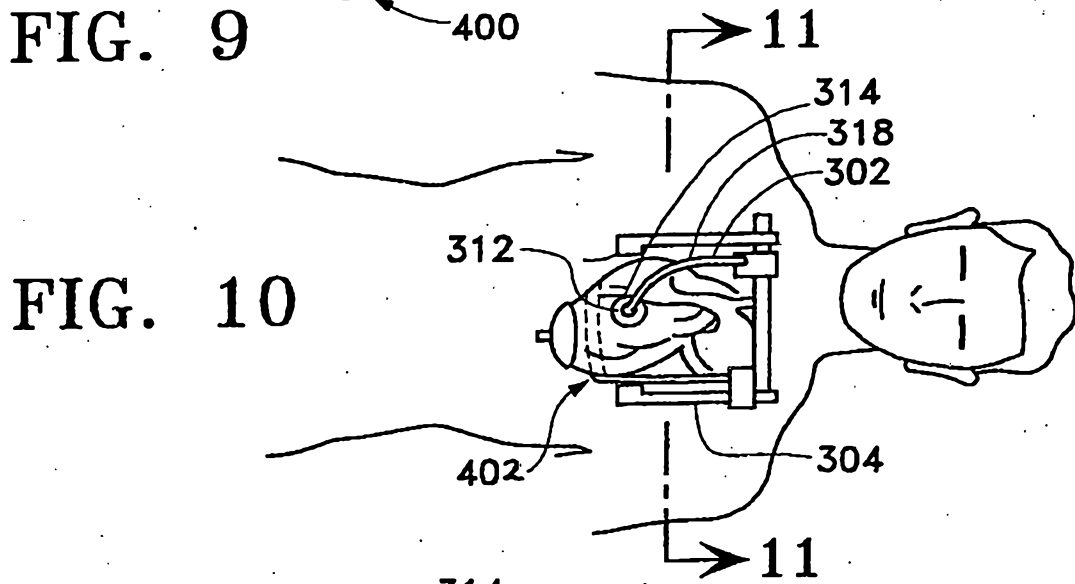

FIG. 10

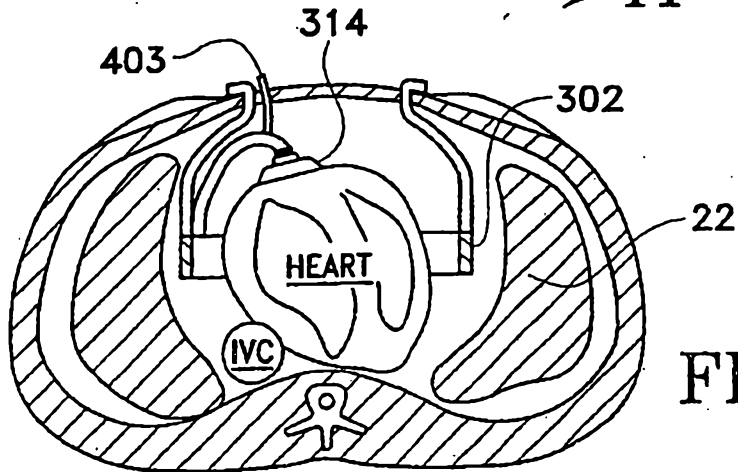

FIG. 11

7/11

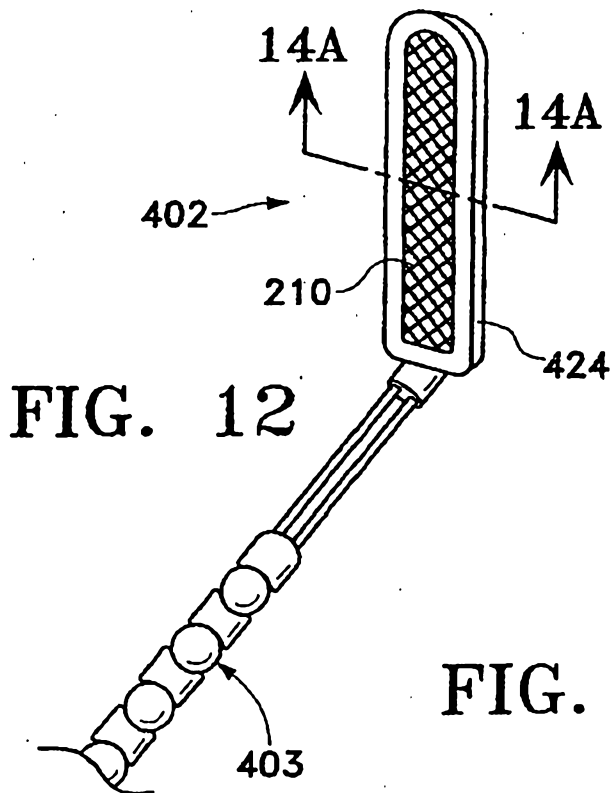

FIG. 12

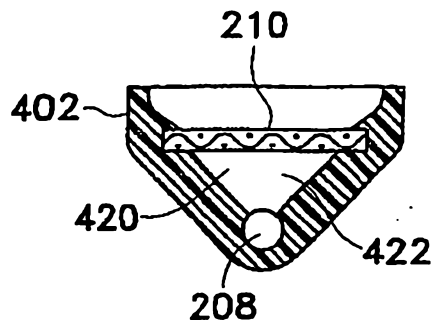

FIG. 14A

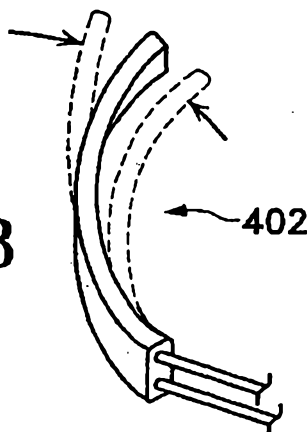
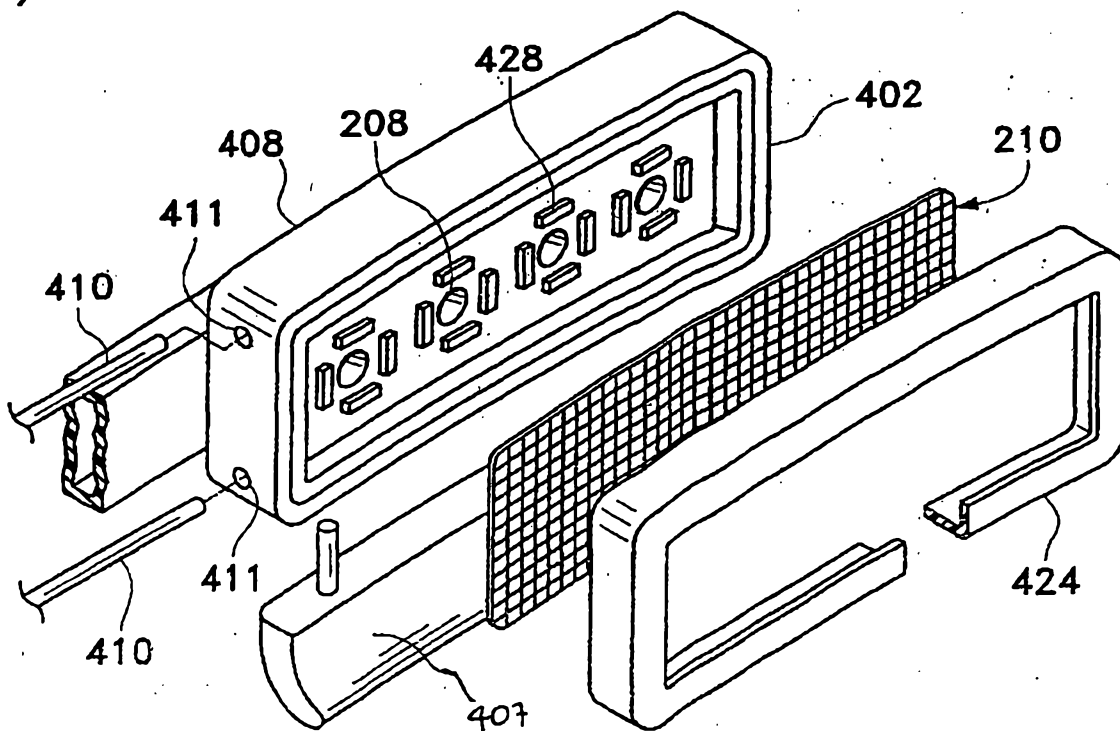

FIG. 13

FIG. 14B



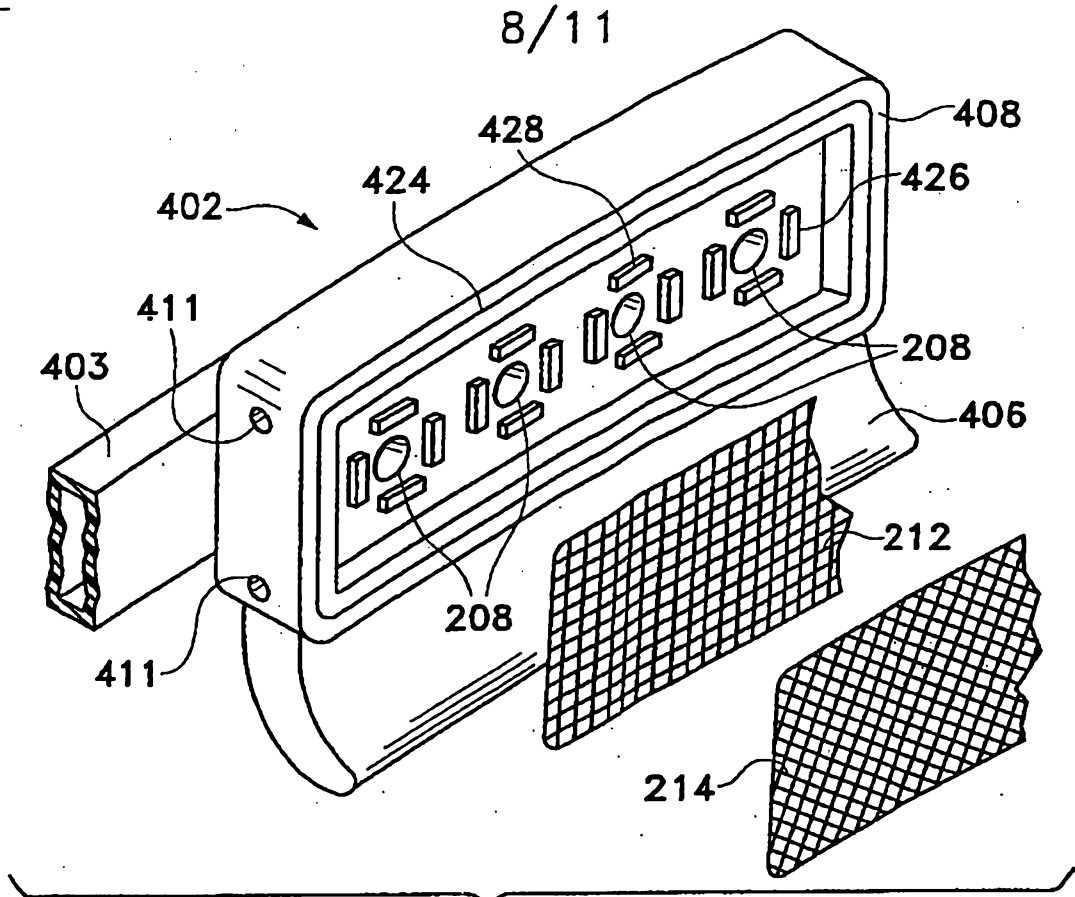

FIG. 14C

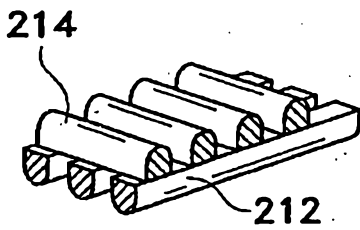

FIG. 15

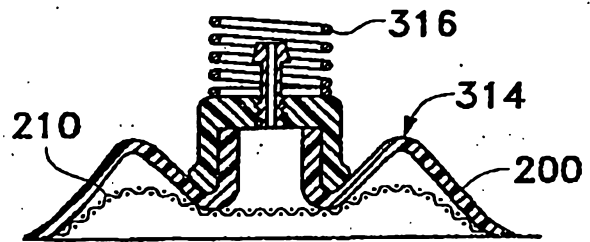

FIG. 16A

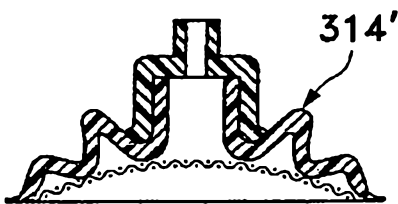

FIG. 17

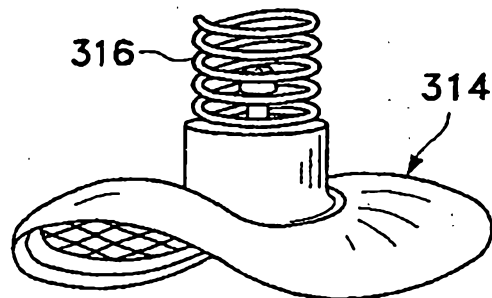

FIG. 16B

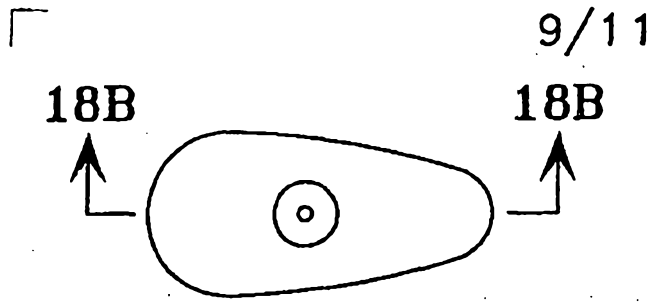

FIG. 18A

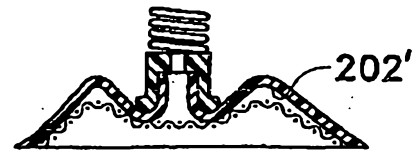

FIG. 18B

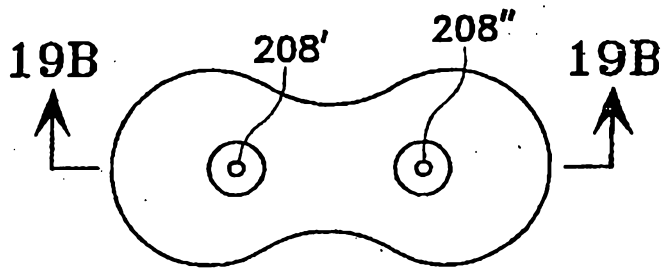

FIG. 19A

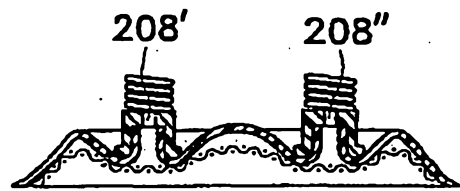

FIG. 19B

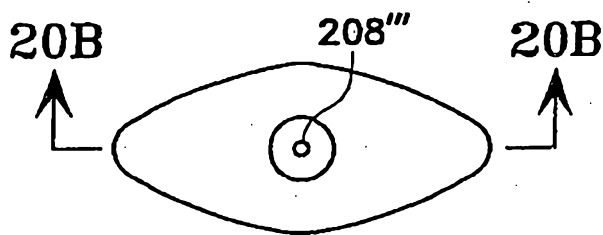

FIG. 20A

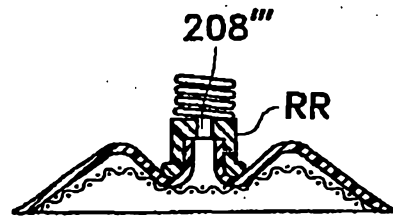

FIG. 20B

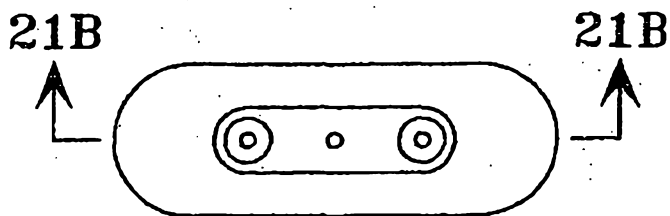

FIG. 21A

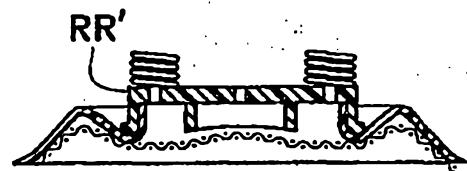

FIG. 21B

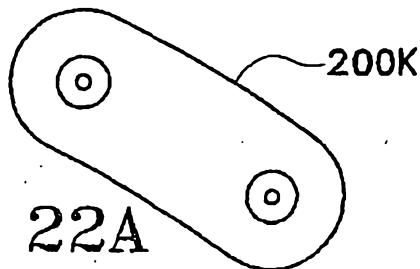

FIG. 22A

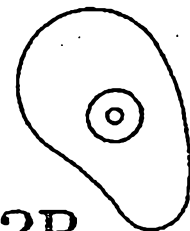

FIG. 22B

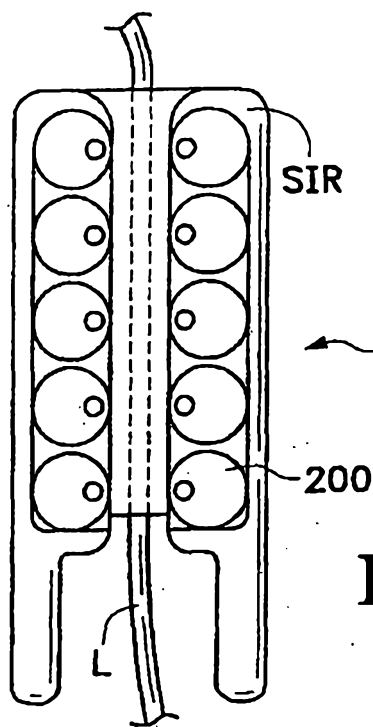

FIG. 23
(PRIOR ART)

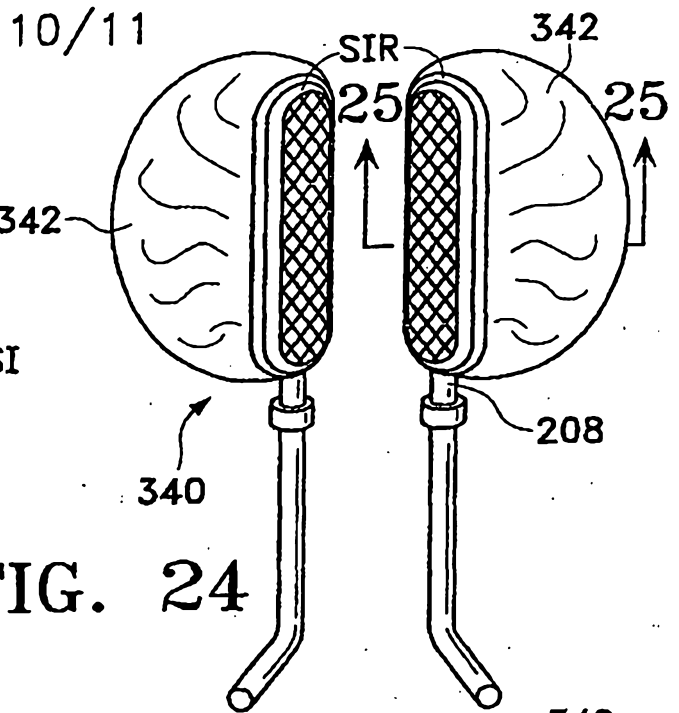

FIG. 24

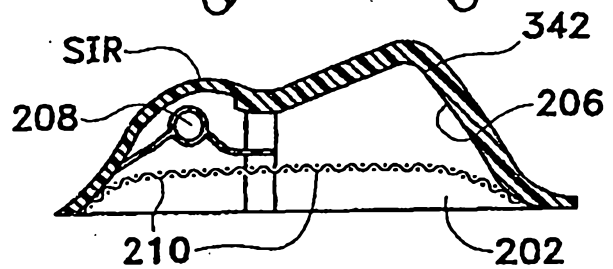

FIG. 25

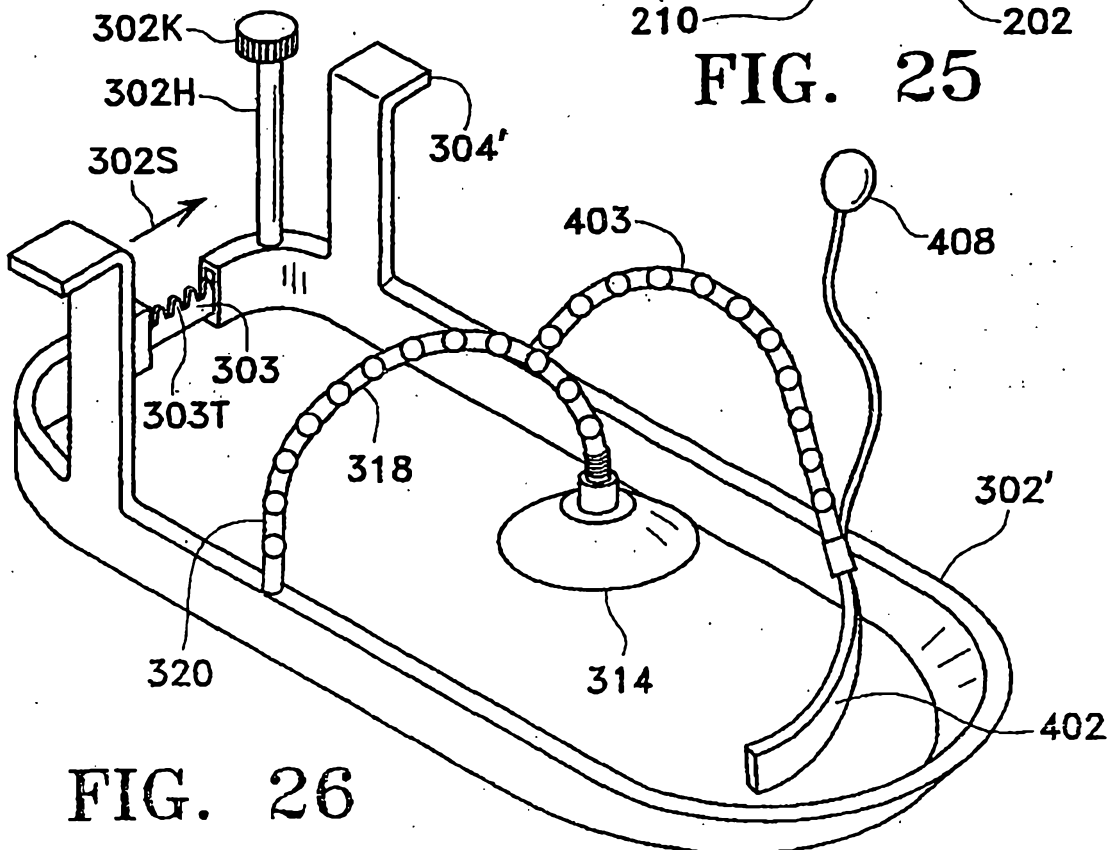

FIG. 26

11/11

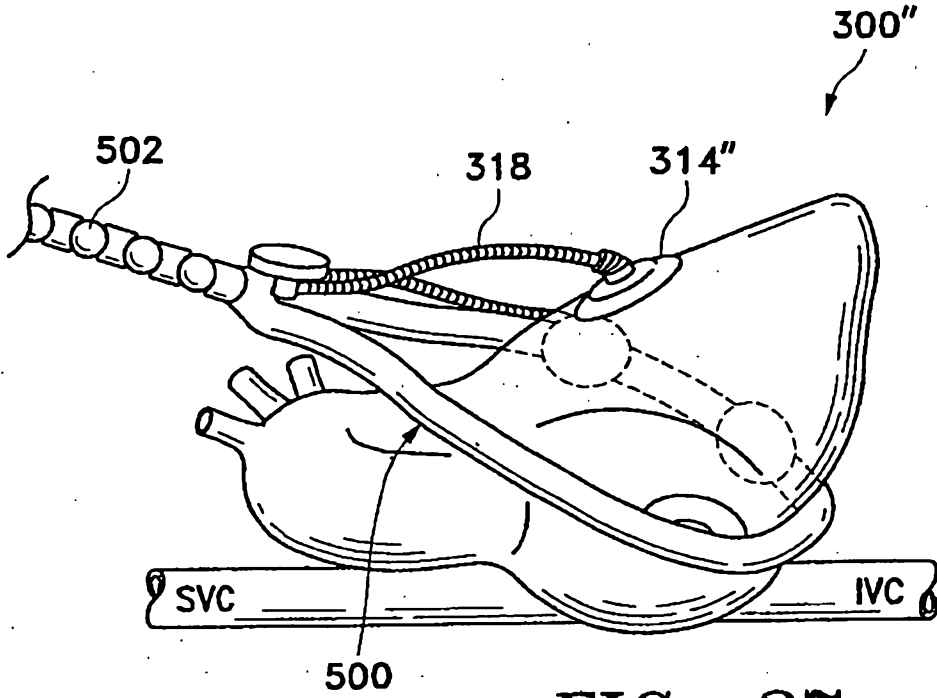

FIG. 27

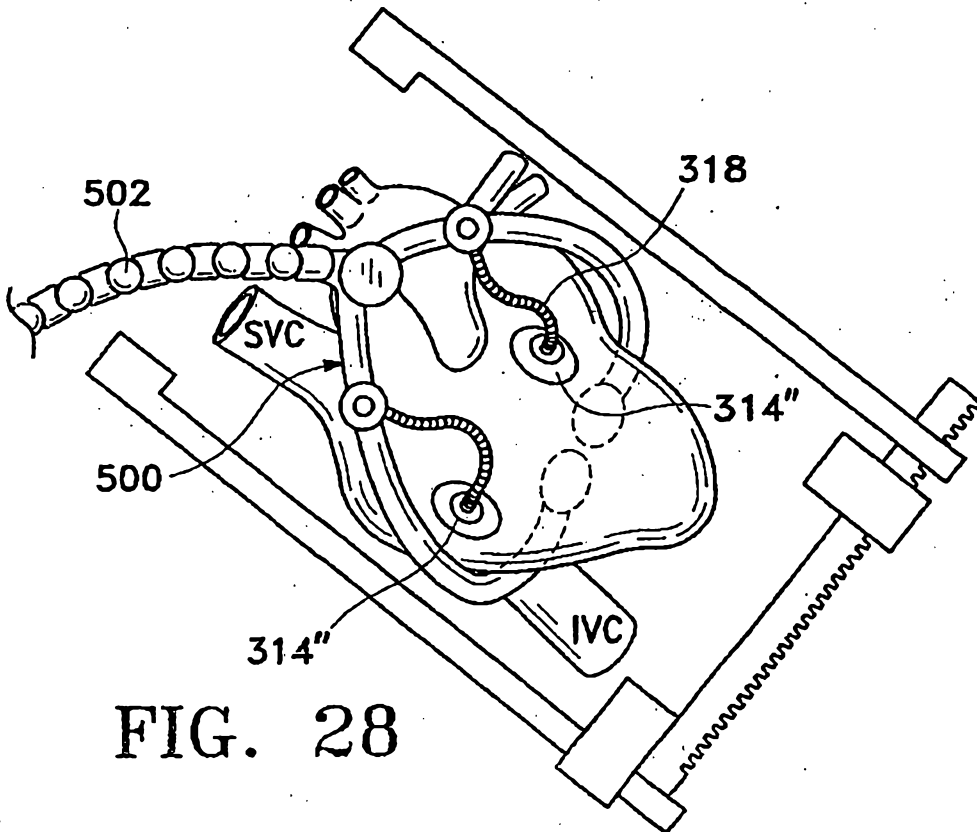

FIG. 28