



US 20060262155A1

(19) **United States**

(12) **Patent Application Publication**
Kuwahara et al.

(10) **Pub. No.: US 2006/0262155 A1**

(43) **Pub. Date: Nov. 23, 2006**

(54) **LIQUID DISCHARGING APPARATUS AND LIQUID DISCHARGING METHOD**

(30) **Foreign Application Priority Data**

Oct. 1, 2002 (JP) P2002-288442

Nov. 29, 2002 (JP) P2002-348148

(75) Inventors: **Soichi Kuwahara**, Kanagawa (JP);
Hiroshi Udagawa, Tokyo (JP)

Publication Classification

(51) **Int. Cl.**
B41J 29/393 (2006.01)

(52) **U.S. Cl.** **347/19**

Correspondence Address:

RADER FISHMAN & GRAUER PLLC
LION BUILDING
1233 20TH STREET N.W., SUITE 501
WASHINGTON, DC 20036 (US)

(57) **ABSTRACT**

In a liquid discharging method for discharging droplets from a plurality of droplet discharging portions of a liquid discharging head, an actual pattern is created to indicate the discharging states of the droplets from the liquid discharging portions, and information about a defective liquid discharging portion having discharging failure is obtained by checking the discharging states. According to the information, the defective liquid discharging portion is prohibited from discharging, and discharging of droplets from a liquid discharging portion near the defective liquid discharging portion is controlled to reduce the influence of discharging failure of the defective discharging portion, and to correct image information on a recording medium.

(73) Assignee: **SONY CORPORATION**

(21) Appl. No.: **11/492,959**

(22) Filed: **Jul. 26, 2006**

Related U.S. Application Data

(62) Division of application No. 10/670,526, filed on Sep. 26, 2003.

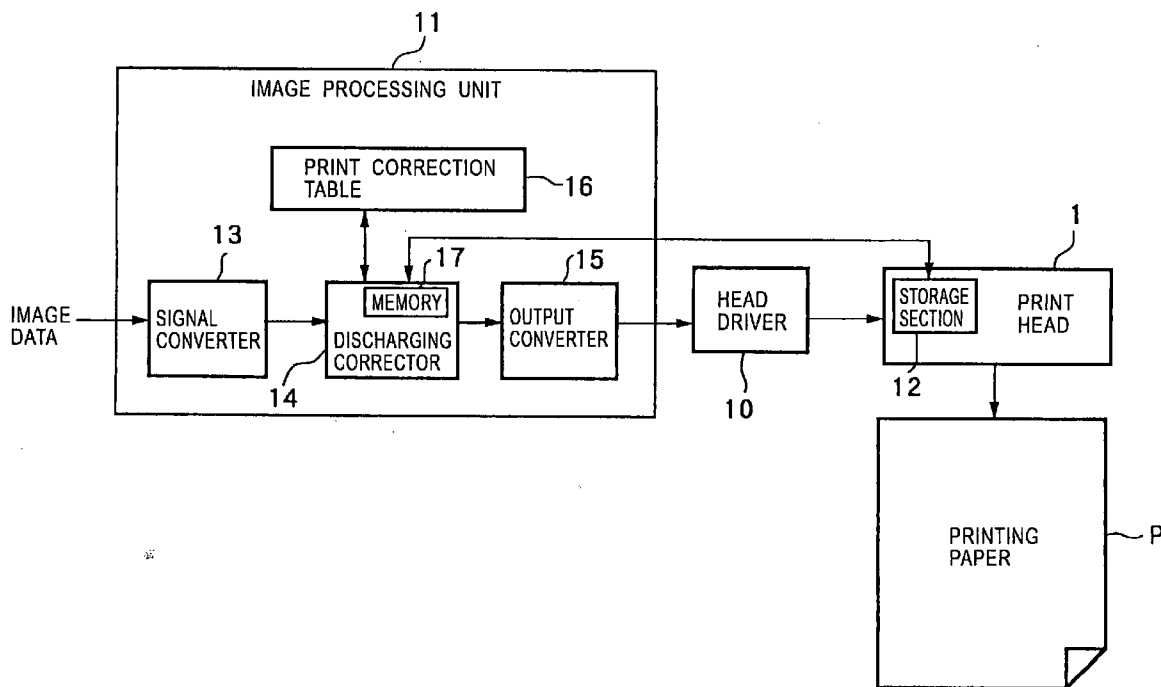

FIG. 1

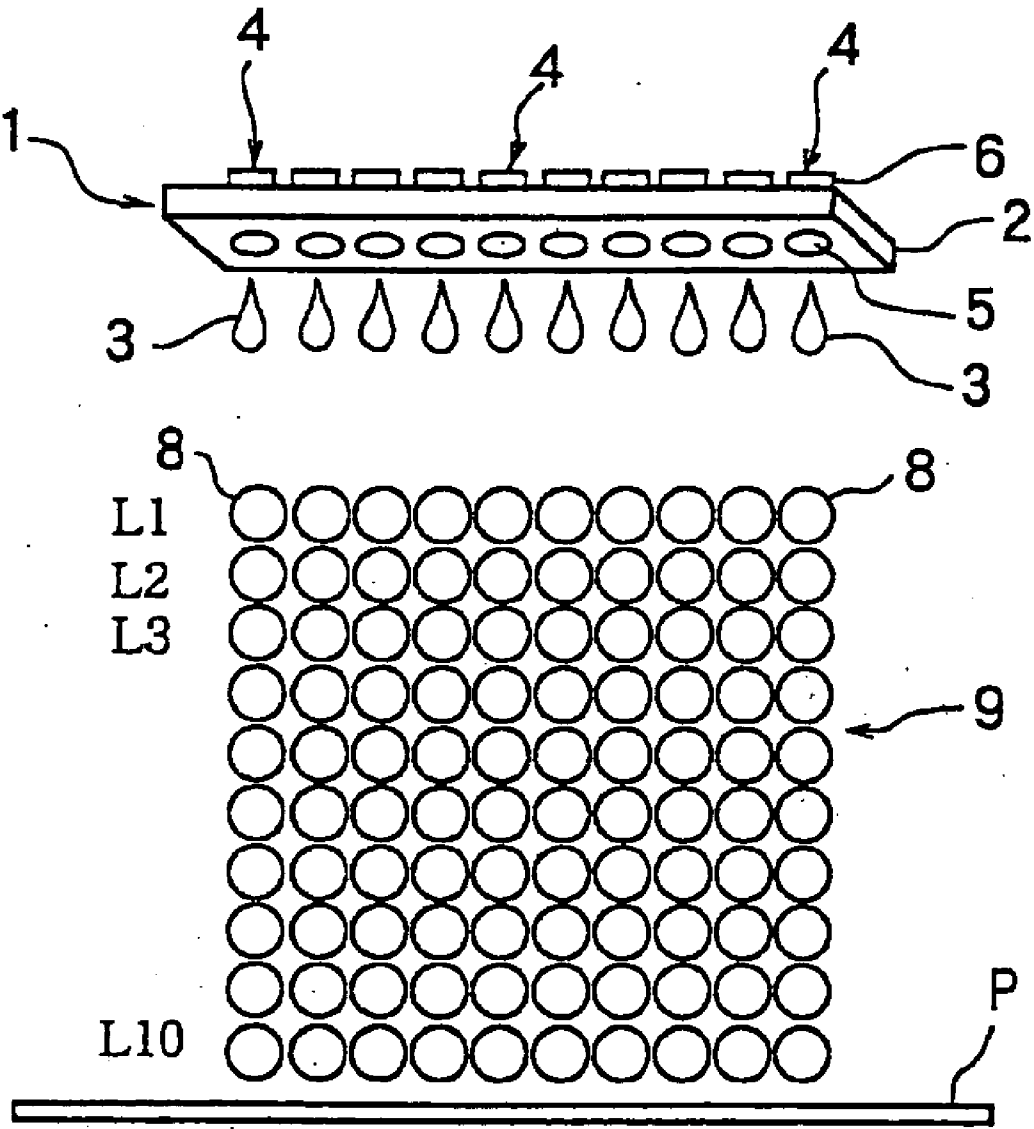

FIG. 2A

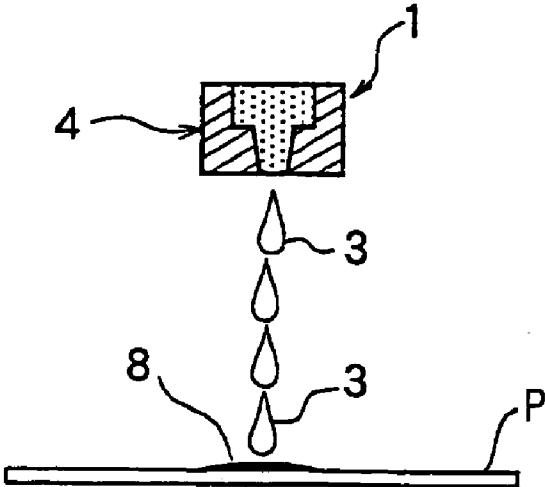

FIG. 2B

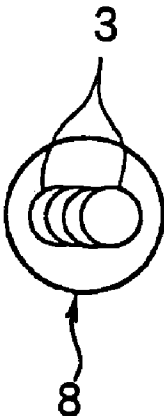

FIG. 3

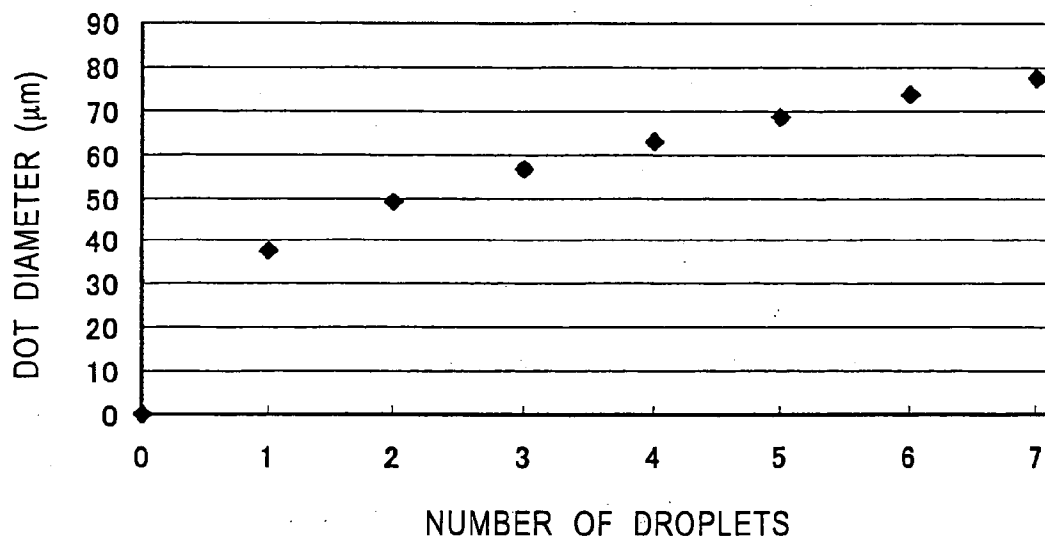

FIG. 4

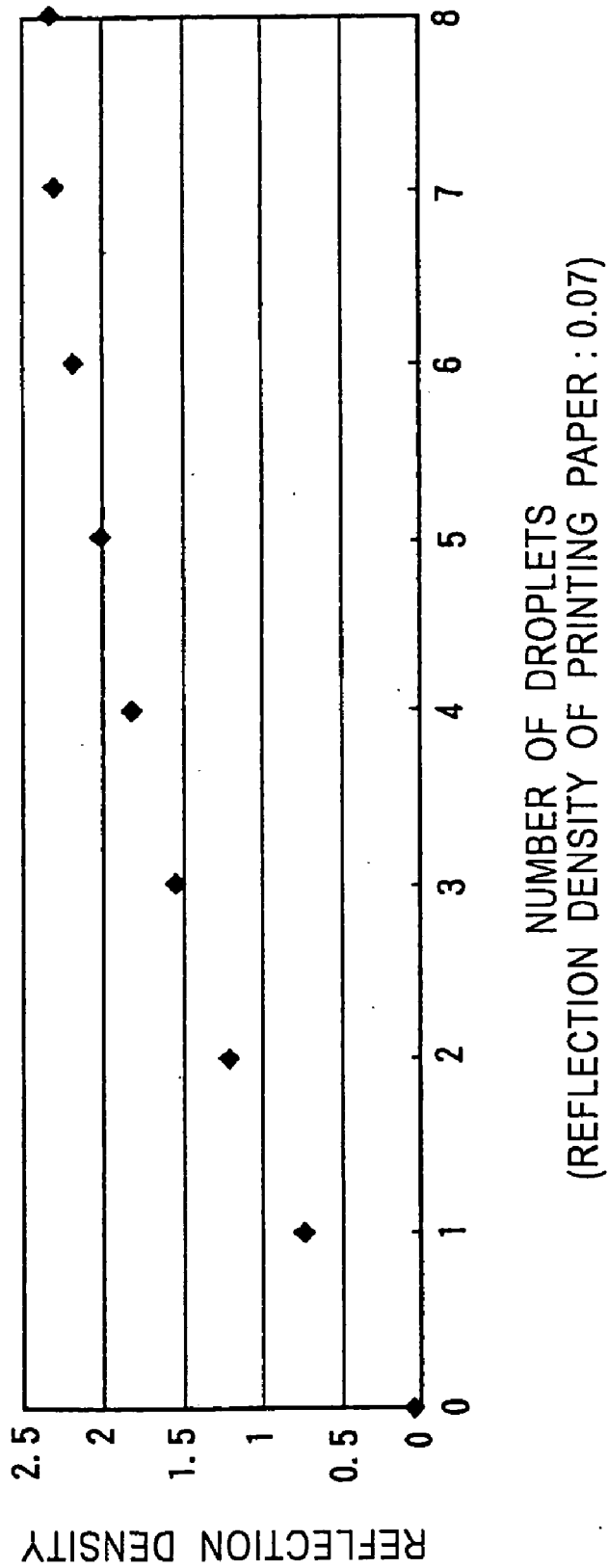

FIG. 5

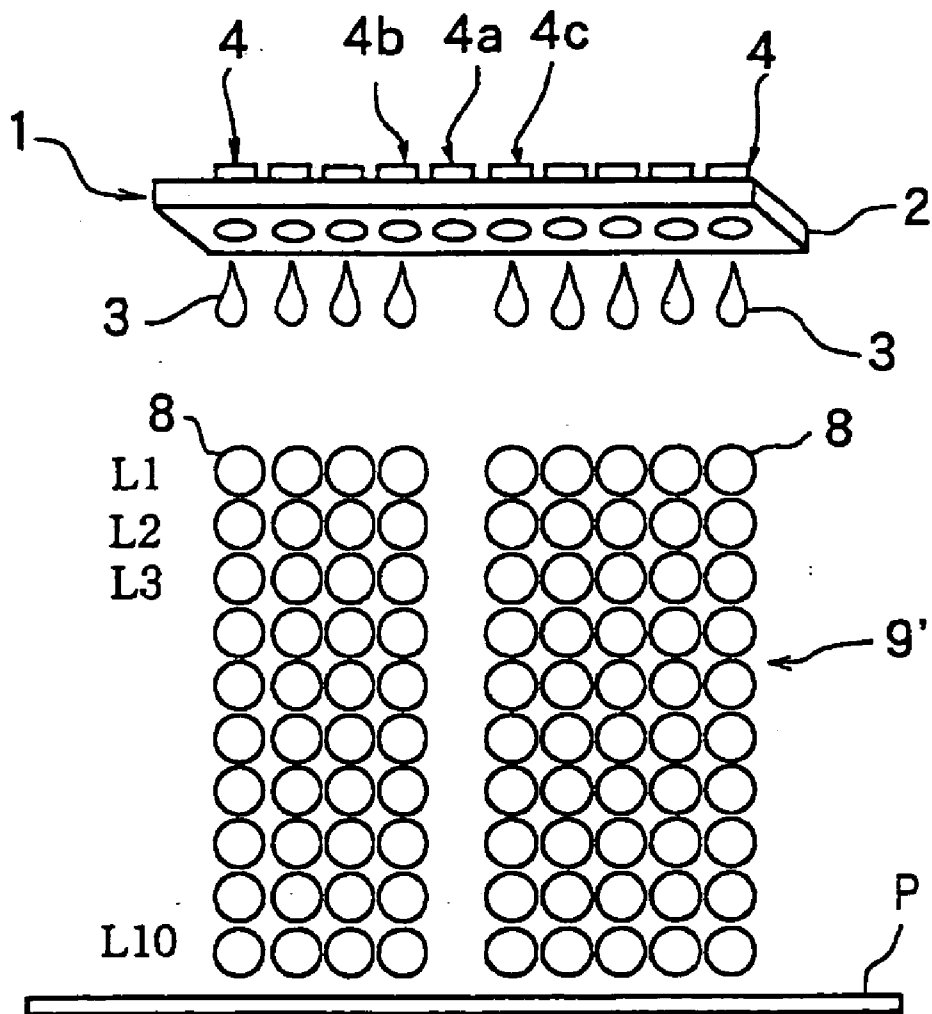

FIG. 6

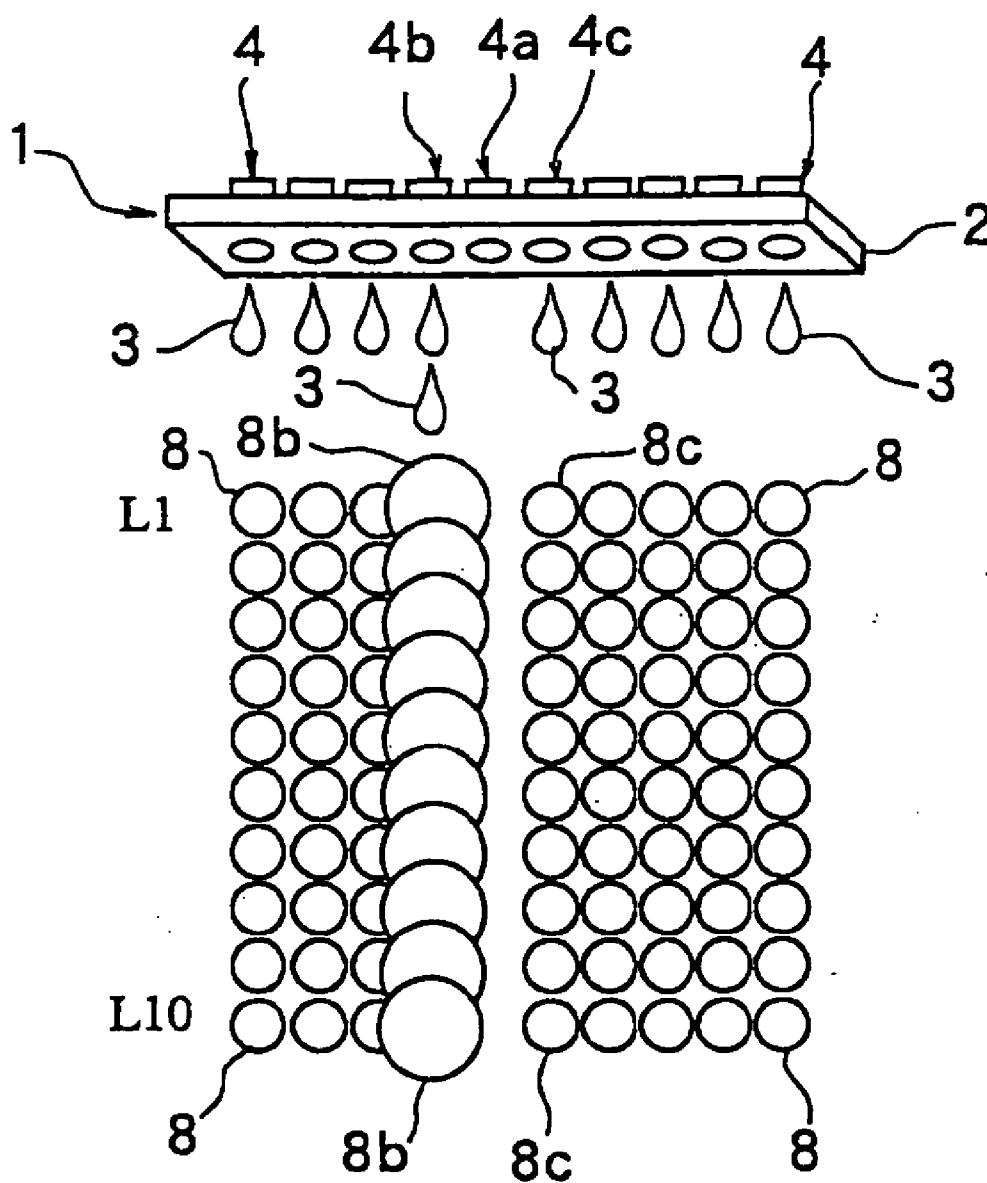

FIG. 7

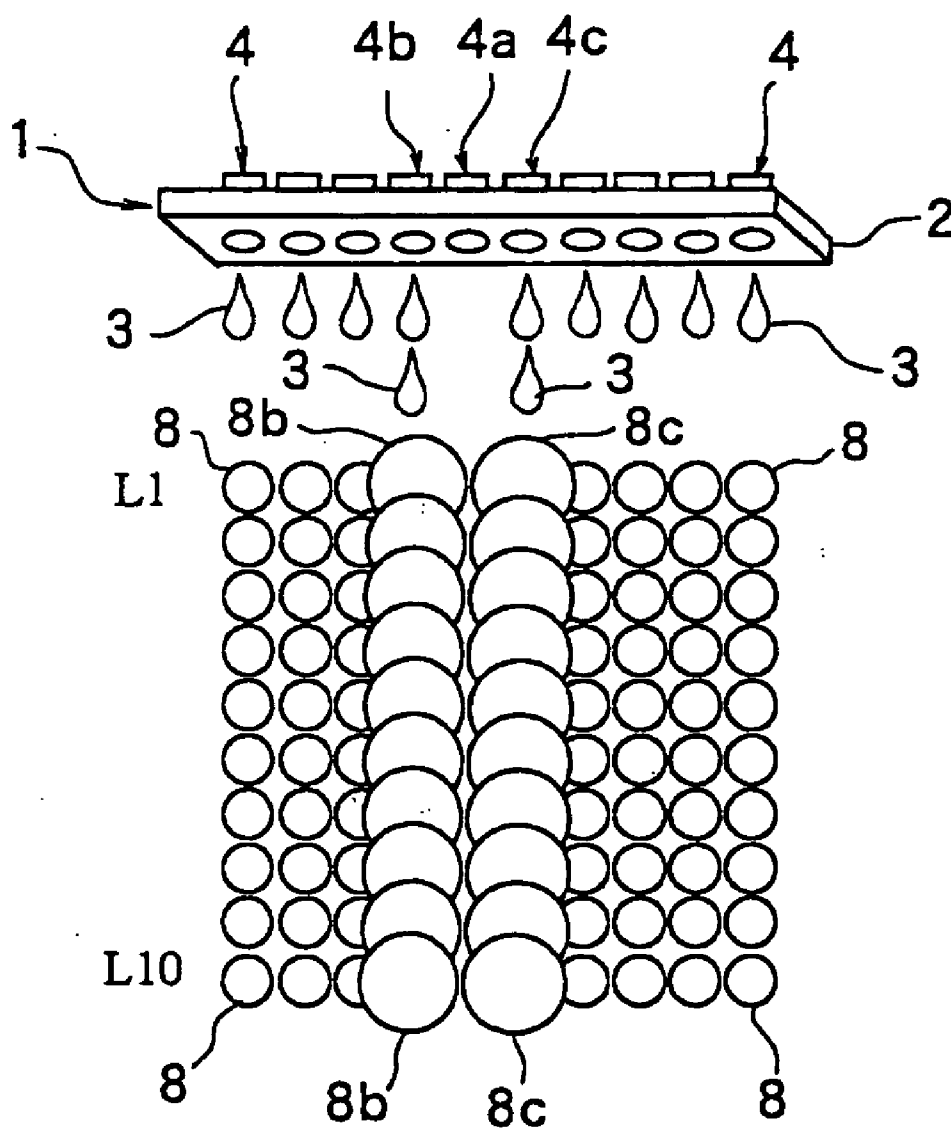

FIG. 8

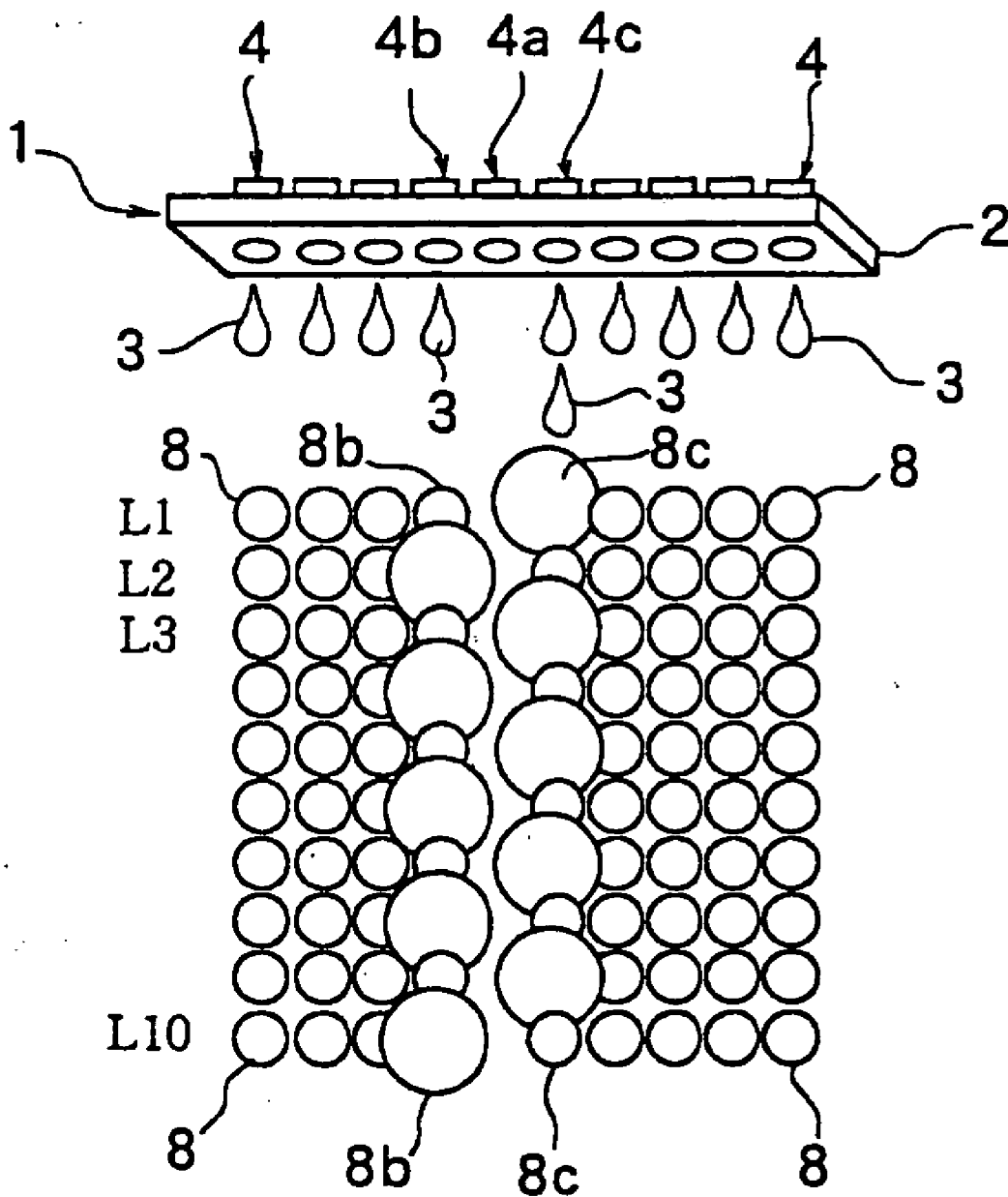

FIG. 9

ORIGINAL PRINT INFORMATION			ODD LINE			EVEN LINE		
A_{n-1}	A_n	A_{n+1}	B_{n-1}	B_n	B_{n+1}	B_{n-1}	B_n	B_{n+1}
0	0	0	0	0	0	0	0	0
0	0	1	0	0	1	0	0	1
0	0	2	0	0	2	0	0	2
0	0	3	0	0	3	0	0	3
0	0	4	0	0	4	0	0	4
0	0	5	0	0	5	0	0	5
0	1	0	0	0	1	0	0	1
0	1	1	0	0	2	0	0	2
0	1	2	0	0	3	0	0	3
0	1	3	0	0	4	0	0	4
0	1	4	0	0	5	0	0	5
0	1	5	0	0	6	0	0	6
0	2	0	0	0	2	0	0	2
0	2	1	0	0	3	0	0	3
0	2	2	0	0	4	0	0	4
0	2	3	0	0	5	0	0	5
0	2	4	0	0	6	0	0	6
0	2	5	0	0	7	0	0	7
0	3	0	0	0	3	0	0	3
0	3	1	0	0	4	0	0	4
0	3	2	0	0	5	0	0	5
0	3	3	0	0	6	0	0	6
0	3	4	0	0	7	0	0	7
0	3	5	0	0	8	0	0	8
0	4	0	0	0	4	0	0	4
0	4	1	0	0	5	0	0	5
0	4	2	0	0	6	0	0	6
0	4	3	0	0	7	0	0	7
0	4	4	0	0	8	0	0	8
0	4	5	0	0	8	0	0	8
0	5	0	0	0	5	0	0	5
0	5	1	0	0	6	0	0	6
0	5	2	0	0	7	0	0	7
0	5	3	0	0	8	0	0	8
0	5	4	0	0	8	0	0	8

FIG. 10

ORIGINAL PRINT INFORMATION			ODD LINE			EVEN LINE		
A_{n-1}	A_n	A_{n+1}	B_{n-1}	B_n	B_{n+1}	B_{n-1}	B_n	B_{n+1}
0	5	5	0	0	8	0	0	8
1	0	0	1	0	0	1	0	0
1	0	1	1	0	1	1	0	1
1	0	2	1	0	2	1	0	2
1	0	3	1	0	3	1	0	3
1	0	4	1	0	4	1	0	4
1	0	5	1	0	5	1	0	5
1	1	0	2	0	0	2	0	0
1	1	1	1	0	2	2	0	1
1	1	2	1	0	3	1	0	3
1	1	3	1	0	4	2	0	3
1	1	4	1	0	5	2	0	4
1	1	5	1	0	6	2	0	5
1	2	0	3	0	0	3	0	0
1	2	1	2	0	3	3	0	2
1	2	2	2	0	4	3	0	3
1	2	3	2	0	5	3	0	4
1	2	4	2	0	6	3	0	5
1	2	5	2	0	7	3	0	6
1	3	0	4	0	0	4	0	0
1	3	1	3	0	4	4	0	3
1	3	2	3	0	5	4	0	4
1	3	3	3	0	6	4	0	5
1	3	4	3	0	7	4	0	6
1	3	5	3	0	8	4	0	7
1	4	0	5	0	0	5	0	0
1	4	1	4	0	5	5	0	4
1	4	2	4	0	6	5	0	5
1	4	3	4	0	7	5	0	6
1	4	4	4	0	8	5	0	7
1	4	5	4	0	8	5	0	8
·	·	·	·	·	·	·	·	·
·	·	·	·	·	·	·	·	·
·	·	·	·	·	·	·	·	·
5	5	5	8	0	8	8	0	8

FIG. 11

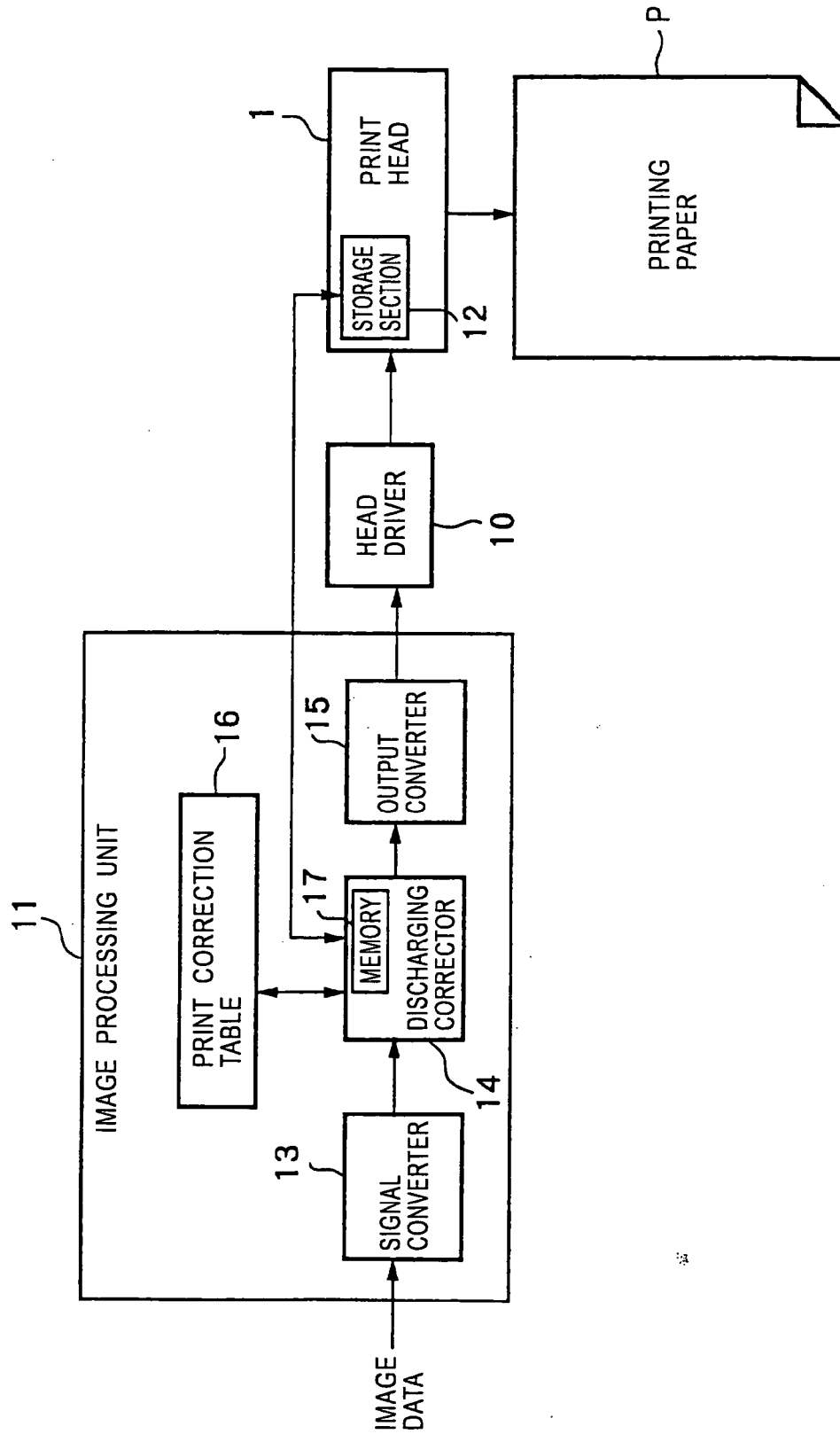

FIG. 12

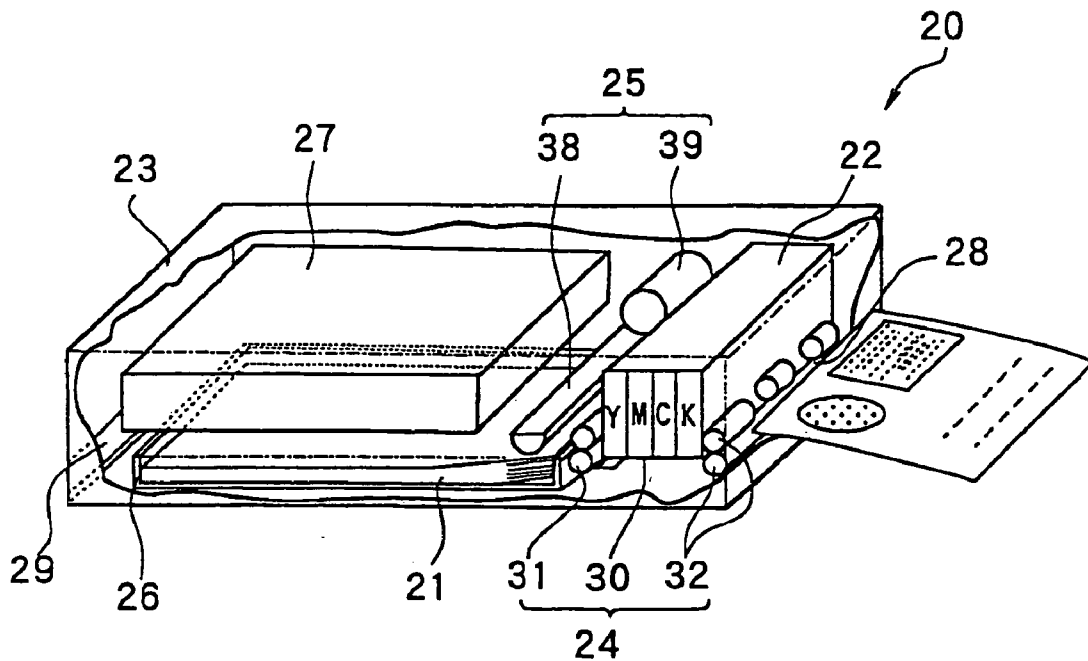

FIG. 13

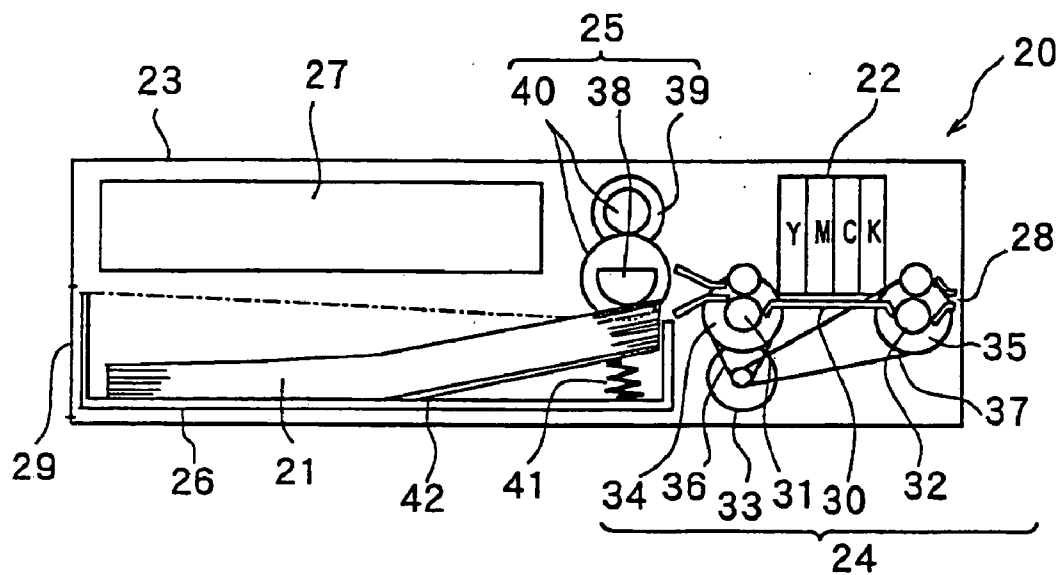

FIG. 14

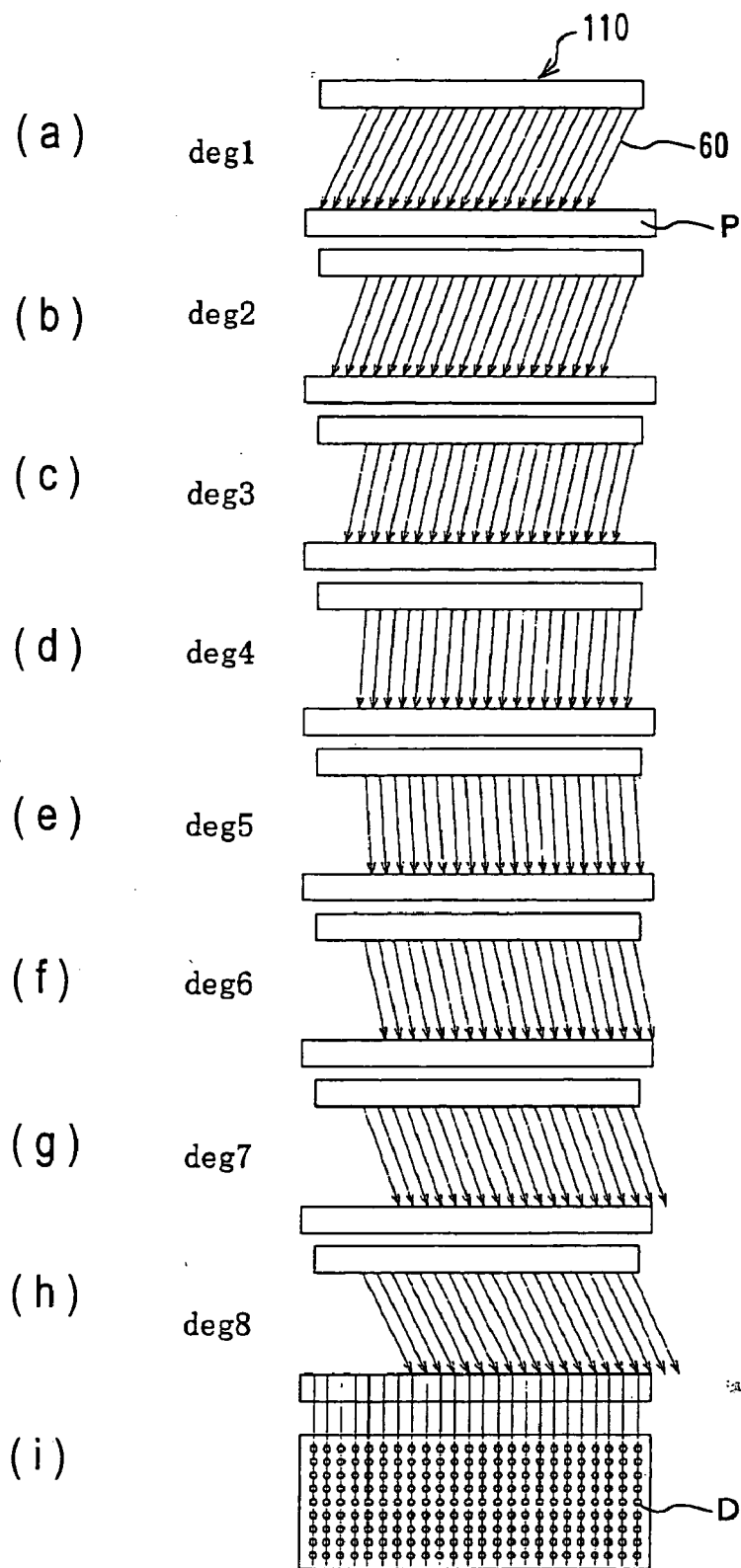

FIG. 15

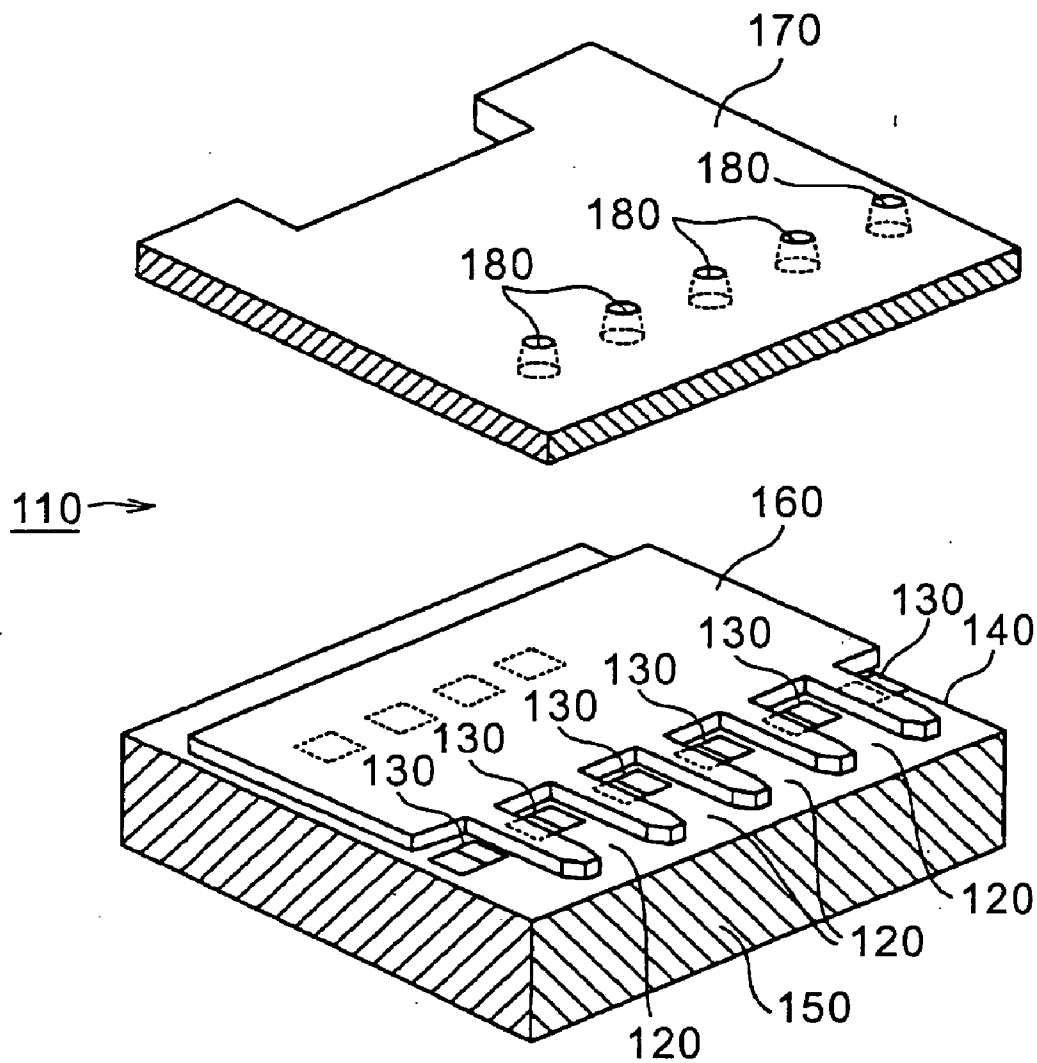

FIG. 16A

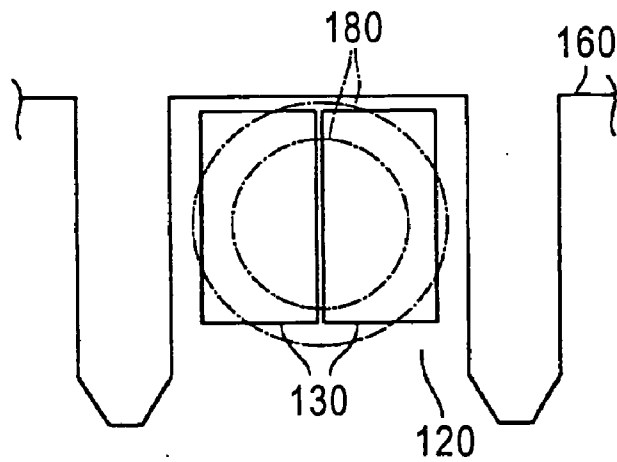

FIG. 16B

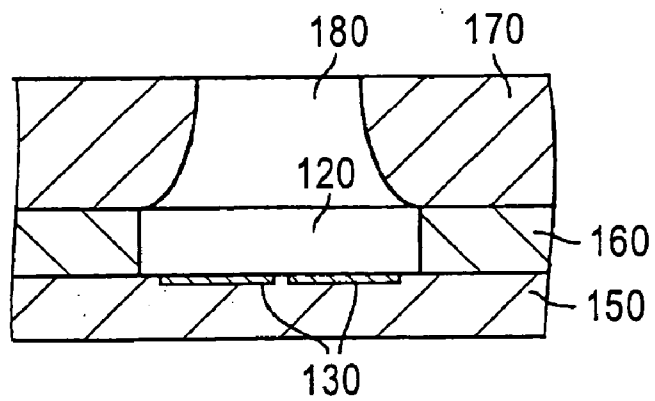

FIG. 17

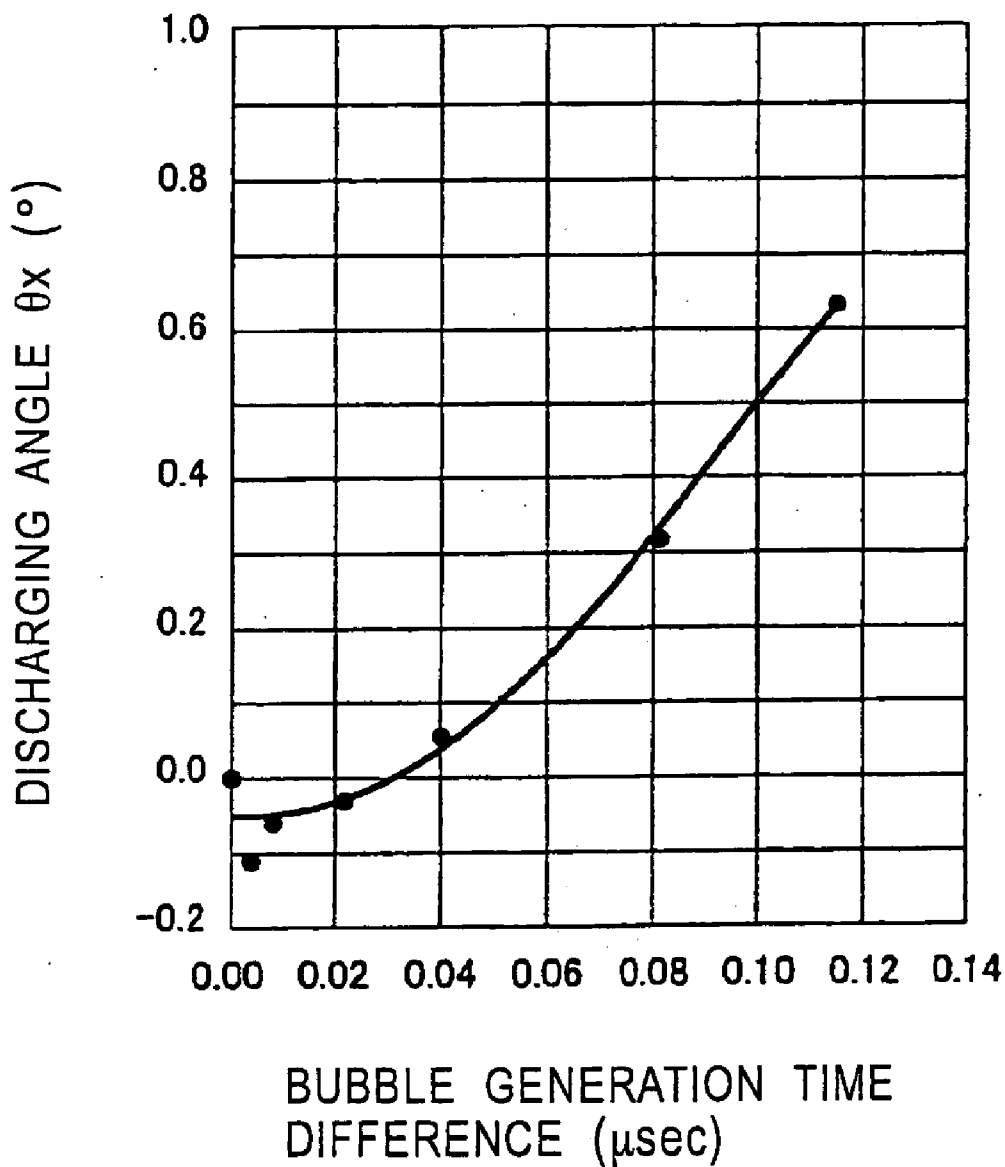

FIG. 18

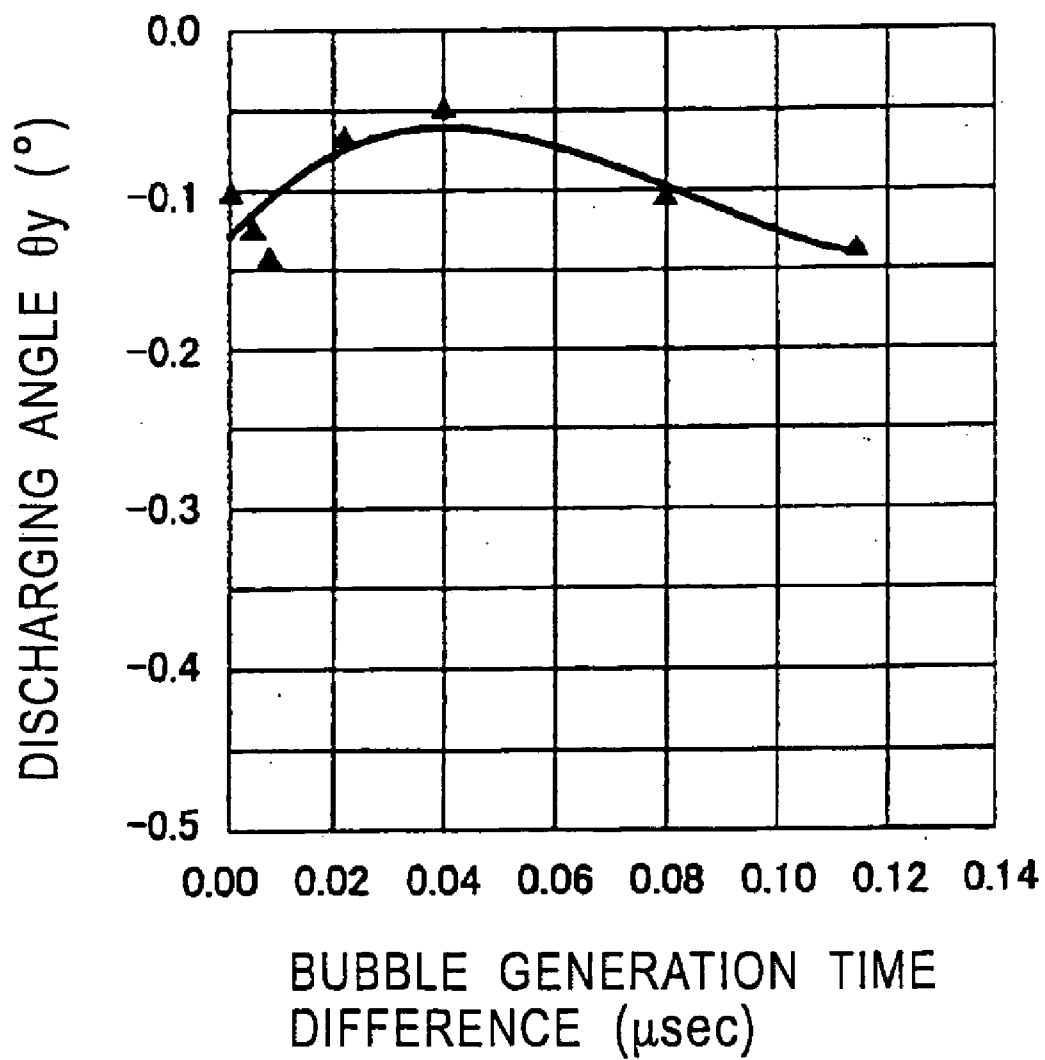

FIG. 19

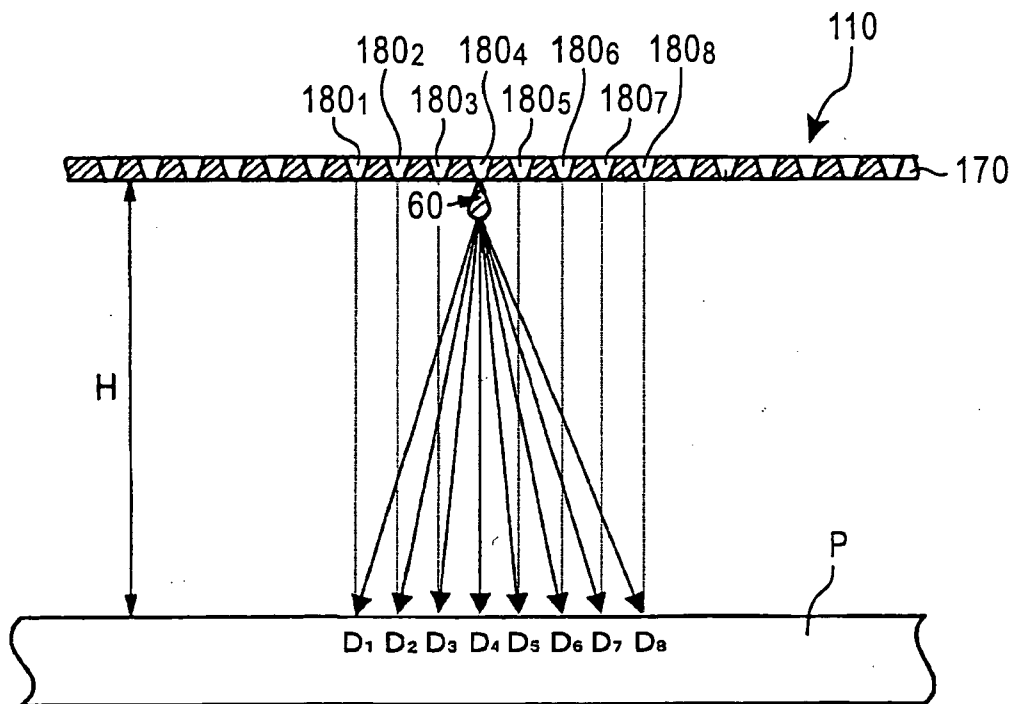

FIG. 20

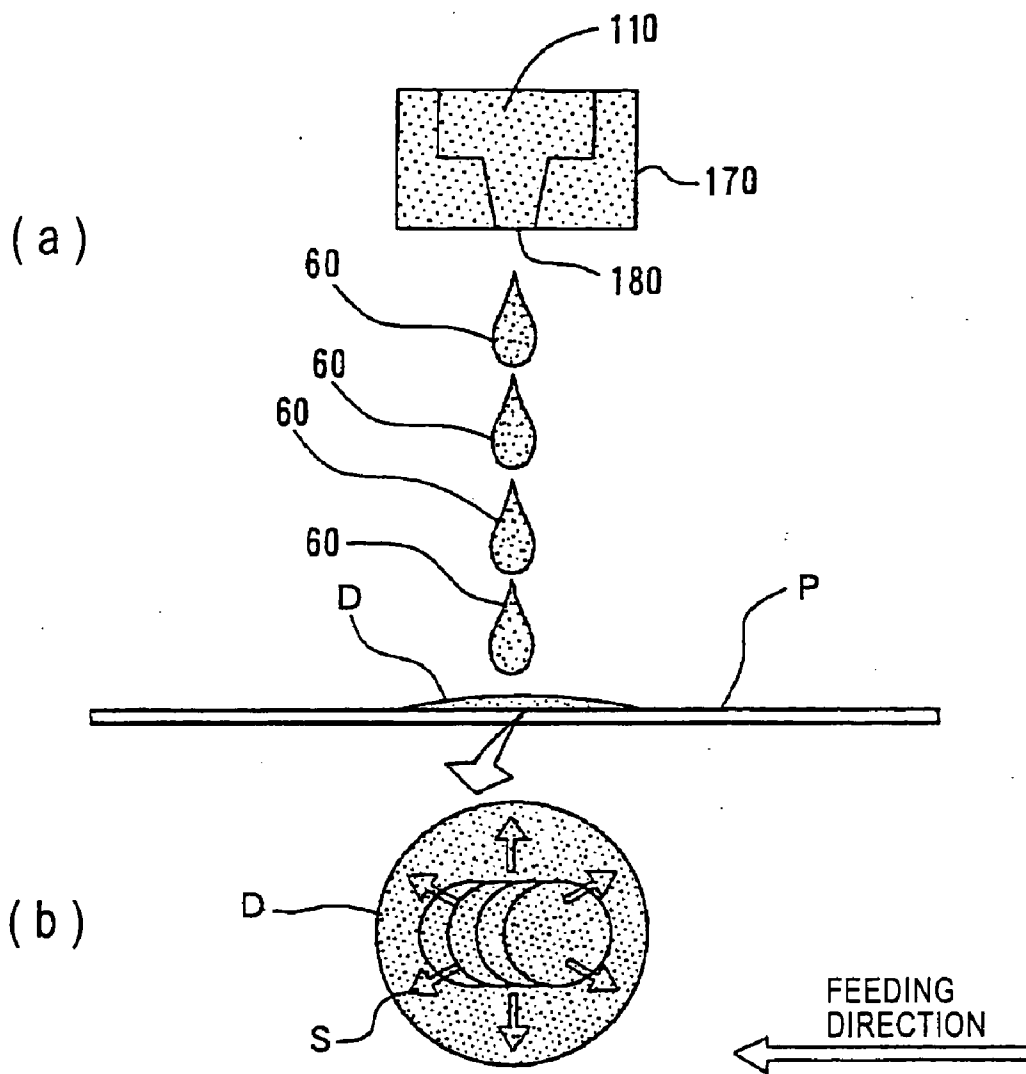

FIG. 21

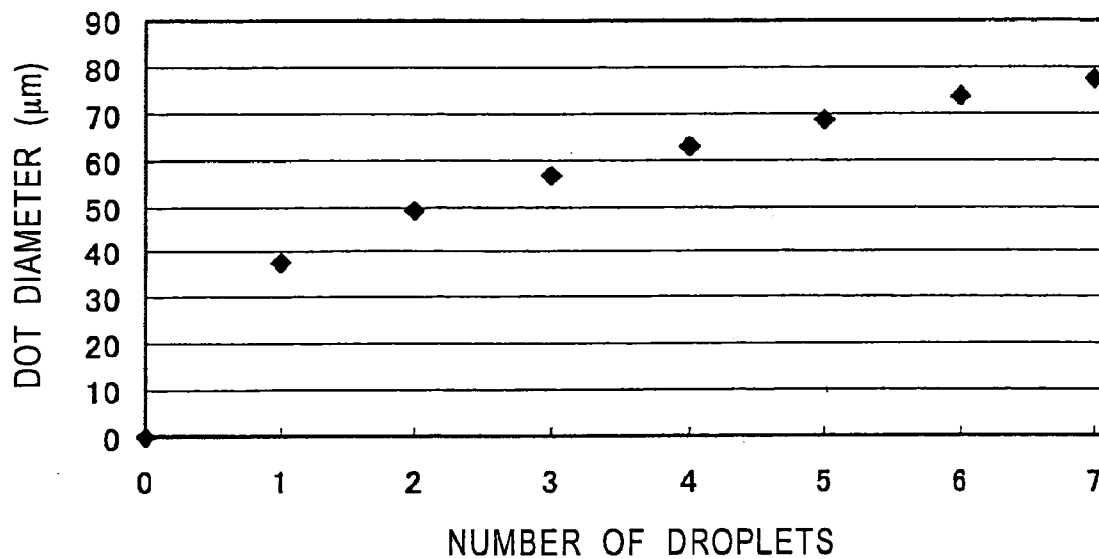

FIG. 22

		D ₁	D ₂	D ₃	D ₄	D ₅	D ₆	D ₇	D ₈	D ₉
A	PNM1	DP1	DP2	DP3	DP4	DP5	DP6	DP7	DP8	DP9
	PNM2	DP-1	DP1	DP2	DP3	DP4	DP5	DP6	DP7	DP8
	PNM3	DP-2	DP-1	DP1	DP2	DP3	DP4	DP5	DP6	DP7
	PNM4	DP-3	DP-2	DP-1	DP1	DP2	DP3	DP4	DP5	DP6
	PNM5	DP-4	DP-3	DP-2	DP-1	DP1	DP2	DP3	DP4	DP5
	PNM6	DP-5	DP-4	DP-3	DP-2	DP-1	DP1	DP2	DP3	DP4
	PNM7	DP-6	DP-5	DP-4	DP-3	DP-2	DP-1	DP1	DP2	DP3
B	PNM1	DP-7	DP-6	DP-5	DP-4	DP-3	DP-2	DP-1	DP1	DP2
	PNM2	DP1	DP2	DP3	DP4	DP5	DP6	DP7	DP8	DP9
	PNM3	DP-1	DP1	DP2	DP3	DP4	DP5	DP6	DP7	DP8
	PNM4	DP-2	DP-1	DP1	DP2	DP3	DP4	DP5	DP6	DP7
	PNM5	DP-3	DP-2	DP-1	DP1	DP2	DP3	DP4	DP5	DP6
	PNM6	DP-4	DP-3	DP-2	DP-1	DP1	DP2	DP3	DP4	DP5
	PNM7	DP-5	DP-4	DP-3	DP-2	DP-1	DP1	DP2	DP3	DP4
C	PNM1	DP-6	DP-5	DP-4	DP-3	DP-2	DP-1	DP1	DP2	DP3
	PNM2	DP-7	DP-6	DP-5	DP-4	DP-3	DP-2	DP-1	DP1	DP2
	PNM3	DP1	DP2	DP3	DP4	DP5	DP6	DP7	DP8	DP9
	PNM4	DP-1	DP1	DP2	DP3	DP4	DP5	DP6	DP7	DP8
	PNM5	DP-2	DP-1	DP1	DP2	DP3	DP4	DP5	DP6	DP7
	PNM6	DP-3	DP-2	DP-1	DP1	DP2	DP3	DP4	DP5	DP6
	PNM7	DP-4	DP-3	DP-2	DP-1	DP1	DP2	DP3	DP4	DP5
D	PNM1	DP-5	DP-4	DP-3	DP-2	DP-1	DP1	DP2	DP3	DP4
	PNM2	DP-6	DP-5	DP-4	DP-3	DP-2	DP-1	DP1	DP2	DP3
	PNM3	DP-7	DP-6	DP-5	DP-4	DP-3	DP-2	DP-1	DP1	DP2
	PNM4	DP1	DP2	DP3	DP4	DP5	DP6	DP7	DP8	DP9
	PNM5	DP-1	DP1	DP2	DP3	DP4	DP5	DP6	DP7	DP8
	PNM6	DP-2	DP-1	DP1	DP2	DP3	DP4	DP5	DP6	DP7
	PNM7	DP-3	DP-2	DP-1	DP1	DP2	DP3	DP4	DP5	DP6
E	PNM1	DP-4	DP-3	DP-2	DP-1	DP1	DP2	DP3	DP4	DP5
	PNM2	DP-5	DP-4	DP-3	DP-2	DP-1	DP1	DP2	DP3	DP4
	PNM3	DP-6	DP-5	DP-4	DP-3	DP-2	DP-1	DP1	DP2	DP3
	PNM4	DP-7	DP-6	DP-5	DP-4	DP-3	DP-2	DP-1	DP1	DP2
	PNM5	DP1	DP2	DP3	DP4	DP5	DP6	DP7	DP8	DP9
	PNM6	DP-1	DP1	DP2	DP3	DP4	DP5	DP6	DP7	DP8
	PNM7	DP-2	DP-1	DP1	DP2	DP3	DP4	DP5	DP6	DP7
F	PNM1	DP-3	DP-2	DP-1	DP1	DP2	DP3	DP4	DP5	DP6
	PNM2	DP-4	DP-3	DP-2	DP-1	DP1	DP2	DP3	DP4	DP5
	PNM3	DP-5	DP-4	DP-3	DP-2	DP-1	DP1	DP2	DP3	DP4
	PNM4	DP-6	DP-5	DP-4	DP-3	DP-2	DP-1	DP1	DP2	DP3
	PNM5	DP-7	DP-6	DP-5	DP-4	DP-3	DP-2	DP-1	DP1	DP2
	PNM6	DP1	DP2	DP3	DP4	DP5	DP6	DP7	DP8	DP9
	PNM7	DP-1	DP1	DP2	DP3	DP4	DP5	DP6	DP7	DP8

FIG. 24

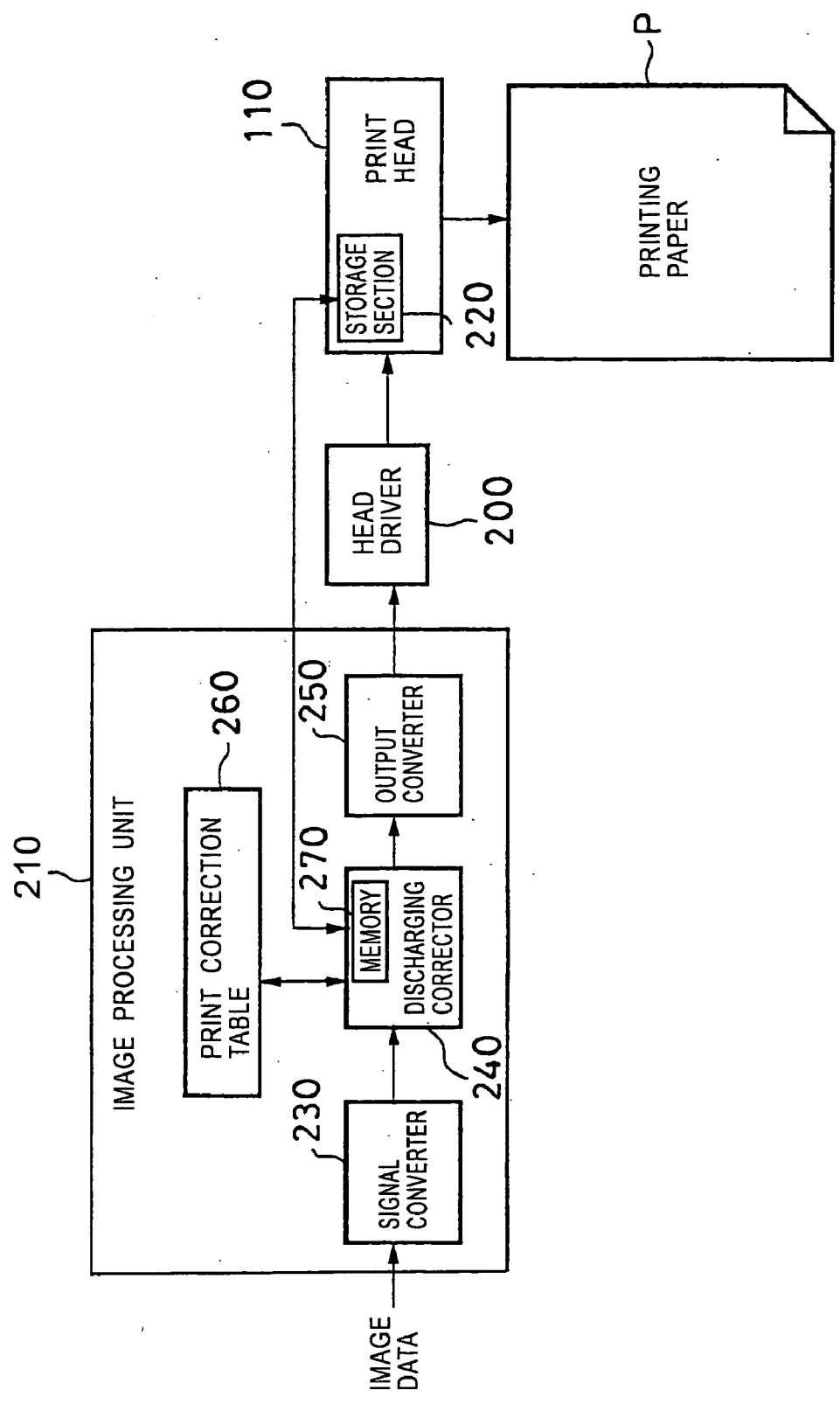

FIG. 25

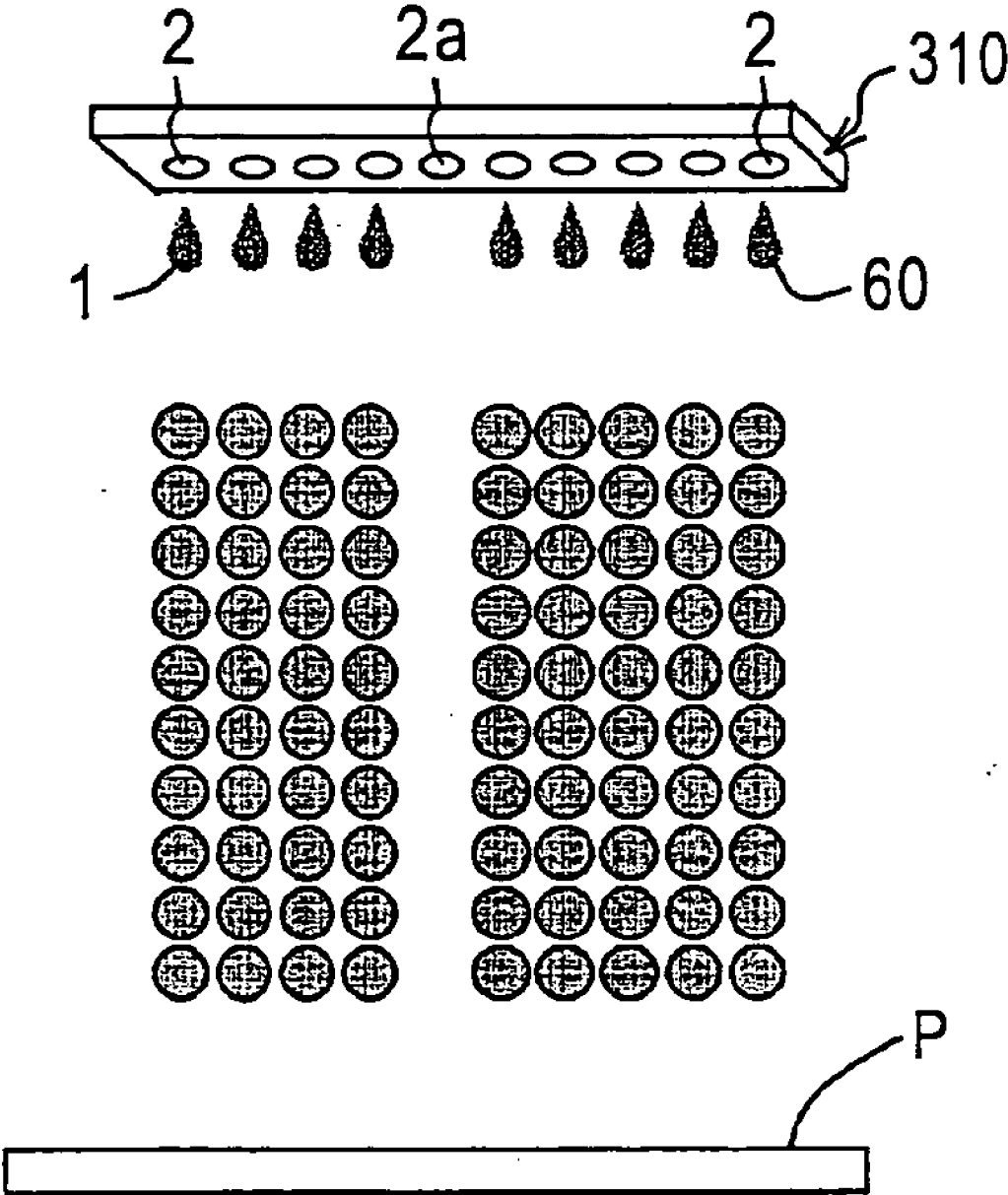

FIG. 26

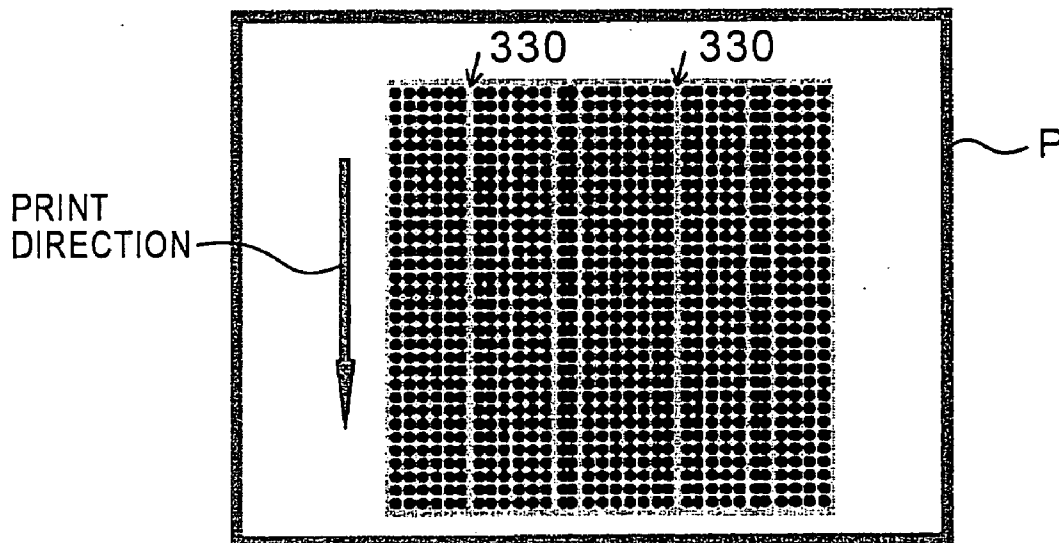
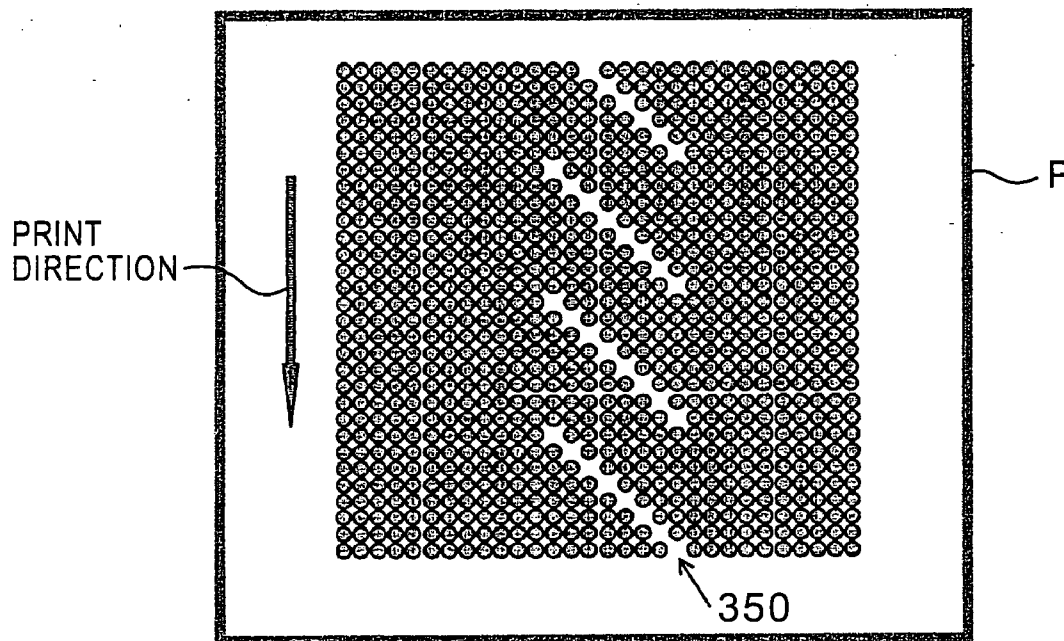

FIG. 27



LIQUID DISCHARGING APPARATUS AND LIQUID DISCHARGING METHOD

CROSS REFERENCE TO RELATED APPLICATIONS

[0001] This application is a divisional application of and claims priority from U.S. application Ser. No. 10/670,526, filed Sep. 26, 2003, the entire contents of the above documents of which is incorporated by reference.

BACKGROUND OF THE INVENTION

[0002] 1. Field of the Invention

[0003] The present invention relates to a liquid discharging apparatus having a head in which a plurality of liquid discharging portions, each having a nozzle, are arranged in a specific direction, and to a liquid discharging method using the head.

[0004] 2. Description of the Related Art

[0005] Ink-jet printers are known as liquid discharging apparatuses. One type of ink-jet printer is a serial printer in which droplets are discharged from a head onto a recording medium while moving the head in the lateral direction of the recording medium, and in which the recording medium is moved in the feeding direction. Another type of ink-jet printer is a line printer having a line head extending along the overall width of the recording medium, in which only the recording medium is moved in a direction perpendicular to the lateral direction thereof, and in which droplets are discharged from the line head onto the recording medium (see, for example, Japanese Unexamined Patent Application Publication No. 2002-36522).

[0006] In print heads used in these ink-jet printers, when ink droplets are not discharged from any of the discharging portions for some reason, ink does not adhere to a position on a recording medium corresponding to the discharging portion, and a white stripe appears. This reduces the image quality. In some cases, ink droplets are discharged from a discharging portion in a direction deviating from the allowable range, or the amount of ink discharged from a discharging portion is quite small. These cases also reduce the image quality. In particular, since a line head includes more discharging portions than a serial head, a wider range of variations in ink discharging characteristics occur.

[0007] In a serial head, even when there are some variations in ink discharging characteristics among the discharging portions, the variations can be reduced by a method, called "superimposition", for overlapping dots to bridge gaps between previously printed dots.

[0008] In contrast, since a line head does not move, it cannot perform overprinting on a prerecorded region. For this reason, variations among the discharging portions remain as in the direction in which the discharging portions are arranged, and result in conspicuous stripes.

[0009] Accordingly, in ink-jet printers, measures have been taken so that all the discharging portions of a print head properly discharge ink droplets. In particular, clogging of an ink discharging outlet, for example, due to drying of ink droplets is prevented by maintenance such as cleaning.

[0010] However, for example, in thermal ink-jet printers, problems that cannot be overcome by maintenance some-

times occur: for example, a heater for heating and discharging ink breaks, and an ink chamber malfunctions. In these cases, none of the discharging portions can discharge ink droplets. Since a print head having such a discharging portion cannot be repaired, it has been treated as defective.

[0011] For example, when it is assumed that the possibility of occurrence of such a defective discharging portion is approximately 1/40,000, one out of two hundred print heads, each having two hundred discharging portions, has a defective discharging portion. In this case, half of the print heads having multiple discharging portions, such as line heads, are defective, for example, when the recording paper is A4-sized and the resolution is 600 dpi because approximately five thousand discharging portions are prepared for one color, that is, approximately twenty thousand discharging portions are prepared for four colors. Therefore, the production yields of print heads are significantly reduced.

SUMMARY OF THE INVENTION

[0012] Accordingly, it is an object of the present invention to reduce the occurrence of stripes and to improve print quality by making correction in accordance with variations in discharging characteristics among liquid discharging portions.

[0013] In order to overcome the above problems, a first invention provides a liquid discharging method for discharging droplets from a plurality of liquid discharging portions, the method including the steps of discharging droplets from the liquid discharging portions to form an actual pattern, obtaining information about a defective liquid discharging portion having discharging failure by checking the actual pattern for the discharging states of the droplets, and prohibiting the defective liquid discharging portion from discharging, and controlling discharging of ink droplets from a liquid discharging portion near the defective liquid discharging portion.

[0014] In such a method, information about a defective liquid discharging portion having discharging failure can be obtained by checking the actual pattern for the discharging states of droplets. The defective liquid discharging portion is prohibited from discharging, and discharging of a liquid discharging portion near the defective liquid discharging portion is controlled, thereby correcting discharging of the discharging portions. This reduces the influence of discharging failure of the defective liquid discharging portion.

[0015] A second invention provides a liquid discharging apparatus for forming an image on a recording medium by discharging droplets from a plurality of liquid discharging portions onto the recording medium, the apparatus including a liquid discharging head having the liquid discharging portions, a head driver for controlling the driving of the liquid discharging head, an image processing unit that converts externally input image data into head driving data for driving the liquid discharging head and sends the head driving data to the head driver, and a storage section for storing information about a defective liquid discharging portion, the information being obtained by checking an actual pattern that indicates the discharging states of the droplets from the liquid discharging portions, wherein image formation on the recording medium is corrected by prohibiting the defective liquid discharging portion from discharging, and controlling discharging from a liquid discharging

portion near the defective liquid discharging portion according to the information about the defective liquid discharging portion stored in the storage section.

[0016] In this case, the actual pattern is checked for the discharging states of droplets, information about the defective liquid discharging portion is stored in the storage section, and discharging of droplets from a liquid discharging portion near the defective liquid discharging portion is controlled while prohibiting the defective liquid discharging portion according to the information of the defective liquid discharging portion from the storage section, thereby correcting image formation on the recording medium. This reduces the influence of discharging failure of the defective liquid discharging portion on the image quality, and enhances the production yield of the liquid discharging apparatus.

[0017] A third invention provides a liquid discharging method for discharging droplets from a plurality of liquid discharging portions onto a recording medium while controlling the discharging directions of the droplets, the method including the steps of obtaining information about a defective liquid discharging portion having discharging failure by checking the discharging states of the droplets discharged from the liquid discharging portions, and prohibiting the defective liquid discharging portion from discharging and discharging droplets from a liquid discharging portion different from the defective liquid discharging portion while controlling the discharging direction.

[0018] In such a method, information about a defective liquid discharging portion is obtained, the defective liquid discharging portion is prohibited from discharging, and ink droplets are discharged from a liquid discharging portion different from the defective liquid discharging portion while controlling the discharging direction. This reduces the influence of discharging failure of the defective liquid discharging portion.

[0019] A fourth invention provides a liquid discharging method for forming dot arrays or dots on a recording medium by discharging droplets from a plurality of liquid discharging portions while controlling the discharging direction and changing the dot diameter by the number of the discharged droplets, the method including the steps of obtaining information about a defective liquid discharging portion having discharging failure by checking the discharging states of the droplets discharged from the liquid discharging portions, and prohibiting the defective liquid discharging portion from discharging and discharging droplets from a liquid discharging portion different from the defective liquid discharging portion while controlling the discharging direction.

[0020] In such a method, information about a defective liquid discharging portion is obtained, the defective liquid discharging portion is prohibited from discharging, and ink droplets are discharged from a liquid discharging portion different from the defective liquid discharging portion while controlling the discharging direction. This reduces the influence of discharging failure of the defective liquid discharging portion.

[0021] A fifth invention provides a liquid discharging method for forming dot arrays or dots on a recording medium by discharging droplets from a plurality of liquid

discharging portions while controlling the discharging direction and changing the dot diameter by the number of the discharged droplets, the method including the steps of obtaining information about a defective liquid discharging portion having discharging failure by checking the discharging states of the droplets discharged from the liquid discharging portions, prohibiting the defective liquid discharging portion from discharging and generating new droplet discharging signals for reducing the influence of discharging failure of the defective liquid discharging portion, and discharging droplets from a liquid discharging portion different from the defective liquid discharging portion while controlling the discharging direction according to the new droplet discharging signals.

[0022] In such a method, information about a defective liquid discharging portion is obtained, the defective liquid discharging portion is prohibited from discharging, new droplet discharging signals are generated to reduce the influence of discharging failure of the defective liquid discharging portion, and droplets are discharged from a liquid discharging portion different from the defective liquid discharging portion while controlling the discharging direction according to the new droplet discharging signals in order to change the dot diameter. This reduces the influence of discharging failure of the defective liquid discharging portion.

[0023] A sixth invention provides a liquid discharging apparatus for forming dot arrays or dots on a recording medium by discharging droplets from a plurality of liquid discharging portions onto the recording medium while controlling the discharging direction, the apparatus including a liquid discharging head having the liquid discharging portions, a head driver for controlling the driving of the liquid discharging head, a processing unit that converts externally input signals into droplet discharging signals for driving the liquid discharging head and sends the droplet discharging signals to the head driver, and a storage section for storing information about a defective liquid discharging portion, the information being obtained by checking the discharging states of the droplets from the liquid discharging portions, wherein the influence of discharging failure of the defective droplet discharging portion is reduced by prohibiting the defective liquid discharging portion from discharging and discharging droplets from a liquid discharging portion different from the defective liquid discharging portion while controlling the discharging direction, according to the information about the defective liquid discharging portion stored in the storage section.

[0024] In this case, the discharging states of droplets discharged from the liquid discharging portions are checked, and information about a defective liquid discharging portion is stored in the storage section. According to the information about the defective liquid discharging portion stored in the storage section, the defective liquid discharging portion is prohibited from discharging, and droplets are discharged from a liquid discharging portion different from the defective liquid discharging portion while changing the discharging direction, thereby changing the dot diameter. This removes the influence of discharging failure of the defective liquid discharging portion.

[0025] A seventh invention provides a liquid discharging apparatus for forming dot arrays or dots on a recording

medium by discharging droplets from a plurality of liquid discharging portions onto the recording medium while controlling the discharging direction and changing the dot diameter by the number of the discharged droplets, the apparatus including a liquid discharging head having the liquid discharging portions, a head driver for controlling the driving of the liquid discharging head, a processing unit that converts externally input signals into droplet discharging signals for driving the liquid discharging head and sends the droplet discharging signals to the head driver, and a storage section for storing information about a defective liquid discharging portion, the information being obtained by checking the discharging states of the droplets discharged from the liquid discharging portions, wherein the influence of discharging failure of the defective droplet discharging portion is reduced by prohibiting the defective liquid discharging portion from discharging and discharging droplets from a liquid discharging portion different from the defective liquid discharging portion while controlling the discharging direction so as to change the dot diameter, according to the information about the defective liquid discharging portion stored in the storage section.

[0026] In this case, the discharging states of droplets discharged from the liquid discharging portions are checked, and information about the defective liquid discharging portion is stored in the storage section. According to the information about the defective liquid discharging portion stored in the storage section, the defective liquid discharging portion is prohibited from discharging, and droplets are discharged from a liquid discharging portion different from the defective liquid discharging portion while changing the discharging direction so as to change the dot diameter. This resolves the influence of discharging failure of the defective liquid discharging portion on the formation of dot arrays or dots.

[0027] An eighth invention provides a liquid discharging apparatus for forming dot arrays or dots on a recording medium by discharging droplets from a plurality of liquid discharging portions onto the recording medium while controlling the discharging direction, the apparatus including a liquid discharging head having the liquid discharging portions, a head driver for controlling the driving of the liquid discharging head, a processing unit that converts externally input signals into droplet discharging signals for driving the liquid discharging head and sends the droplet discharging signals to the head driver, a storage section for storing information about a defective liquid discharging portion, the information being obtained by checking the discharging states of the droplets discharged from the liquid discharging portions, and a discharging corrector for generating new droplet discharging signals to reduce the influence of discharging failure of the defective discharging portion, wherein the influence of discharging failure of the defective droplet discharging portion is removed by prohibiting the defective liquid discharging portion from discharging according to the information about the defective liquid discharging portion, and discharging droplets from a liquid discharging portion different from the defective liquid discharging portion while controlling the discharging direction, according to the new droplet discharging signals generated by the discharging corrector so as to change the dot diameter.

[0028] In this method, information about a defective liquid discharging portion is obtained, and the defective liquid

discharging portion is prohibited from discharging. New droplet discharging signals are generated to reduce the influence of discharging failure of the defective liquid discharging portion, and droplets are discharged from a liquid discharging portion different from the defective liquid discharging portion while controlling the discharging direction according to the new droplet discharging signals so as to change the dot diameter. This allows dot arrays or dots to be formed without any influence of the discharging failure of the defective liquid discharging portion.

[0029] Further objects, features and advantages of the present invention will become apparent from the following description of the preferred embodiments with reference to the attached drawings.

BRIEF DESCRIPTION OF THE DRAWINGS

[0030] **FIG. 1** is a general view showing an image forming method according to an embodiment of the present invention;

[0031] **FIGS. 2A and 2B** are explanatory views showing a state in which an image is formed on a recording medium by discharging ink droplets from a discharging portion of a print head onto the recording medium;

[0032] **FIG. 3** is a graph showing the relationship between the number of ink droplets discharged from the discharging portions to print an image, and the dot diameter;

[0033] **FIG. 4** is a graph showing the relationship between the reflection density of a surface of a recording medium on which dots are solidly printed at a density of, for example, 600 dpi by discharging the ink droplets from the discharging portions, and the number of droplets;

[0034] **FIG. 5** is an explanatory view showing an actual pattern that indicates the discharging states of ink droplets when an ink droplet is not discharged from any of the discharging portions in the print head;

[0035] **FIG. 6** is an explanatory view showing a state in which image formation is corrected by increasing the discharging amount of ink from a discharging portion on one side of the defective discharging portion shown in **FIG. 5**, or the number of discharging shots thereby;

[0036] **FIG. 7** is an explanatory view showing a state in which image formation is corrected by increasing the discharging amount of ink from discharging portions on both sides of the defective discharging portion shown in **FIG. 5**, or the number of discharging shots thereby;

[0037] **FIG. 8** is an explanatory view showing a state in which image formation is corrected by alternately increasing the discharging amount of ink from discharging portions on both sides of the defective discharging portion shown in **FIG. 5** every time one line is printed, or the number of discharging shots thereby;

[0038] **FIG. 9** is a part of a print correction table that lists corrected print information (image formation signals) generated to reduce the influence of discharging failure of the defective discharging portion;

[0039] **FIG. 10** is the other part of the print correction table that lists corrected print information (image formation signals) generated to reduce the influence of discharging failure of the defective discharging portion;

[0040] **FIG. 11** is a block diagram of an image forming apparatus relating to the image forming method of the present invention;

[0041] **FIG. 12** is a partly cutaway perspective view showing a specific example of an ink-jet printer serving as the image forming apparatus;

[0042] **FIG. 13** is a sectional side view of the ink-jet printer;

[0043] **FIG. 14**, consisting of **FIGS. 14a, 14b, 14c, 14d, 14e, 14f, 14g, 14h,** and **14i**, is a general view showing a liquid discharging method according to an embodiment of the present invention in which ink droplets are discharged from a plurality of discharging portions provided in a print head while changing the discharging direction;

[0044] **FIG. 15** is an exploded perspective view of a print head of an ink-jet printer serving as an apparatus directly used to carry out the liquid discharging method of the present invention;

[0045] **FIGS. 16A and 16B** are a plan view and a sectional side view, respectively, showing the arrangement of heating resistors of the print head in more detail;

[0046] **FIG. 17** is a graph showing the relationship between the difference in bubble generation time between two separate heating resistors in **FIGS. 16A and 16B**, and the ink-droplet discharging angle in the X-direction;

[0047] **FIG. 18** is a graph showing the relationship between the difference in bubble generation time between the two split heating resistors in **FIGS. 16A and 16B**, and the ink-droplet discharging angle in the Y-direction;

[0048] **FIG. 19** is a sectional side view showing the relationship between the discharging directions of ink droplets from nozzles provided in a nozzle member of the print head, and printing paper;

[0049] **FIGS. 20(a) and 20(b)** are explanatory views showing a state in which an image is formed on a recording medium by discharging ink droplets from a discharging portion of the print head;

[0050] **FIG. 21** is a graph showing the relationship between the number of ink droplets discharged from the discharging portion, and the dot diameter;

[0051] **FIG. 22** is a table showing the relationship between dots formed by PNM, and discharging portions for discharging ink droplets to form the dots;

[0052] **FIG. 23** is a correction table that lists new droplet discharging signals generated to reduce the influence of discharging failure of the a discharging portion;

[0053] **FIG. 24** is a block diagram of an image forming apparatus relating to the liquid discharging method of the present invention;

[0054] **FIG. 25** is an explanatory view showing a state of a known ink-jet image forming apparatus in which an ink droplet is not discharged from a defective discharging portion;

[0055] **FIG. 26** is an explanatory view showing a state in which white stripes and dark stripes are formed on a recording medium by defective discharging portions of the print head shown in **FIG. 25**; and

[0056] **FIG. 27** is an explanatory view showing a state of another known print head in which lightly colored portions are formed on a recording medium by defective discharging portions.

DESCRIPTION OF THE PREFERRED EMBODIMENTS

[0057] Embodiments of the present invention will be described in detail below with reference to the attached drawings.

[0058] **FIG. 1** is a general view showing a liquid discharging method according to an embodiment corresponding to a first invention of the present invention. In the liquid discharging method of this embodiment, an image is formed on a recording medium by discharging liquid (for example, ink droplets) from a plurality of liquid discharging portions (hereinafter, simply referred to "discharging portions") provided in a liquid discharging head (hereinafter, simply referred to as a "print head") onto the recording medium. In the following description, ink droplets are used as the liquid. Referring to **FIG. 1**, a print head **1** includes a sheet-shaped nozzle member **2**, and a plurality of discharging portions **4** provided in the nozzle member **2** to discharge ink droplets **3**. Each of the discharging portions **4** includes a discharging outlet **5** formed in the nozzle member **2**, and a heating element **6** serving as a driving element for heating and discharging ink in an ink chamber (not shown). In such a state, ink droplets **3** are discharged from the discharging portions **4** of the print head **1** onto a recording medium **P**, thereby forming an image on the recording medium **P**.

[0059] The print head **1** is a line head, and adopts a so-called PNM (Pulse Number Modulation) method that changes the diameter and density of printed dots by the number of ink droplets **3** discharged from the discharging portions **4**. The print head **1** includes ink head portions for four colors, such as yellow **Y**, magenta **M**, cyan **C**, and black **K**, and is disposed so that the discharging outlets **5** for discharging ink droplets **3** point downward.

[0060] For plain explanation, a description will be given of, for example, a case in which yellow, magenta, and black inks are not used, but only cyan ink is used. A maximum of eight droplets are discharged, and five or less droplets are normally discharged to print one dot for each color. The number of droplets for one cyan dot can be changed from zero to eight by the PNM method, as described above. The amount of ink to be discharged is set at, for example, 3.5 pl.

[0061] In such a state, for example, when ink droplets **3** are discharged from the discharging portions **4** of the print head **1** onto printing paper serving as a recording medium **P**, as shown in **FIG. 2A**, the size of a printed dot **8** gradually increases as the number of ink droplets **3** increases, as shown in **FIG. 2B**.

[0062] **FIG. 3** shows the relationship between the number of droplets and the dot diameter. That is, as the number of droplets increases from one to eight, the dot diameter increases from approximately 38 μm to approximately 82 μm . In a case in which four ink droplets are discharged, as shown in **FIG. 2A**, the dot diameter is approximately 63 μm .

[0063] **FIG. 4** shows the relationship between the number of droplets and the reflection density of a surface of the recording medium **P** on which a dot **8** is solidly printed at a

density of, for example, 600 dpi. In this case, when it is assumed that the reflection density of printing paper as the recording medium P is, for example, 0.07, the reflection density increases from approximately 0.75 to approximately 2.4 as the number of droplets increases from one to eight. When four ink droplets are discharged, as shown in FIG. 2A, the reflection density is approximately 1.8.

[0064] In such a liquid discharging method in which an image is formed on a recording medium P by discharging ink droplets 3 from the discharging portions 4 of the printed head 1 onto the recording medium P, an actual pattern is first formed which indicates the discharging states of ink droplets 3 from all the discharging portions 4 corresponding to an image forming region on the recording medium P. That is, ink droplets 3 are discharged using the above-described PNM method to print an actual pattern on the recording medium P by the first dots 8. In this case, when ink droplets 3 are normally discharged from all the discharging portions 4, an actual pattern 9 is formed in which, for example, dots 8 are solidly printed from the first line L1 to the tenth line L10 on the recording medium P by the ink droplets 3, as shown in FIG. 1.

[0065] In contrast, when one discharging portion 4a in the print head 4 cannot properly discharge ink droplets 3, as shown in FIG. 5, ink does not adhere at all or insufficiently adheres to a portion of the recording medium P corresponding to the discharging portion 4a. Consequently, an actual pattern 9' is printed in which a white stripe or a lightly colored portion is formed from the first line L1 to the tenth line L10. FIG. 5 shows a case in which no ink droplet 3 is discharged from the defective discharging portion 4a (undischarged state).

[0066] By checking the discharging states of ink droplets 3 indicated by the actual patterns 9 and 9' thus obtained, information about the defective discharging portion 4a is obtained. That is, on the basis of the actual pattern 9 shown in FIG. 1, it is determined that all the discharging portions 4 can normally work. In contrast, on the basis of the actual pattern 9' shown in FIG. 5, it is determined that one discharging portion 4a is defective, and print information, such as the position of the discharging portion 4a, the amount of ink discharged therefrom, and the number of discharging shots, is obtained. The obtained print information about the defective discharging portion 4a is stored in a storage section provided inside the print head 1 or inside an image processing unit 11 (FIG. 11) which will be described later, or is stored in a storage section provided inside an external control unit such as a host computer. The information may be stored in storage sections provided in some of the print head 1, the image processing unit 11, and the external processing unit.

[0067] According to the print information, the defective discharging portion 4a is prohibited from discharging an ink droplet 3, and discharging of ink droplets 3 from discharging portions near the defective discharging portion 4a, for example, discharging portions 4b and 4c on both sides of the defective discharging portion 4a, is controlled. For example, the amount of ink discharged from the discharging portion 4b (or 4c) next to the defective discharging portion 4a, or the number of discharging shots thereby is increased, as shown in FIG. 6. In this case, print information about the discharging portion 4b (or 4c) is changed in accordance with original

print information about the defective discharging portion 4a. That is, new image forming signals are generated on the basis of original image forming signals for the defective discharging portion 4a and the discharging portions 4b and 4c on both sides thereof to reduce the influence of the discharging failure, and ink droplets 3 are discharged in response to the image forming signals.

[0068] More specifically, the print information about the defective discharging portion 4a is changed to indicate that the discharging portion 4a is prohibited from discharging, and the print information about the next discharging portion 4b (or 4c) is changed to indicate that the number of ink droplets 3 to be discharged therefrom is increased so as to form dots having a diameter larger than the diameter of dots 8 formed according to the original print information about the defective discharging portion 4a. Consequently, as shown in FIG. 6, an increased number of ink droplets 3 are discharged from the discharging portion 4b next to the defective discharging portion 4a, so that dots 8b having a larger diameter are continuously printed on one side of a white stripe formed on the recording medium P corresponding to the defective discharging portion 4a from the first line L1 to the tenth line L10. Extensions of the larger dots 8b cover one side of the white stripe shown in FIG. 5, and make the white stripe less conspicuous, thereby correcting image formation on the recording medium P. Therefore, the influence of discharging failure of the defective discharging portion 4a on the image quality can be reduced, the print head 1 can operate even when any of the discharging portions 4 is defective, and the production yield of the print head 1 can be increased.

[0069] Alternatively, the amount of ink to be discharged from the discharging portions 4b and 4c on both sides of the defective discharging portion 4a or the number of discharging shots thereby may be increased, as shown in FIG. 7. In this case, printing is performed while print information about the discharging portions 4b and 4c is changed on the basis of the original print information about the defective discharging portion 4a.

[0070] More specifically, print information about the next discharging portions 4b and 4c is changed to indicate that the number of ink droplets 3 to be discharged therefrom is increased so as to form dots having a diameter larger than the diameter of dots 8 formed according to the original print information about the defective discharging portion 4a. Consequently, as shown in FIG. 7, an increased number of ink droplets 3 are discharged from the discharging portions 4b and 4c next to the defective discharging portion 4a, so that dots 8b and 8c having a larger diameter are continuously printed on both sides of a white stripe on the recording medium P corresponding to the defective discharging portion 4a from the first line L1 to the tenth line L10. Extensions of the larger dots 8b and 8c cover both sides of the white stripe shown in FIG. 5, and make the white stripe less conspicuous. Thus, image formation on the recording medium P is corrected, and the influence of discharging failure of the defective discharging portion 4a on the image quality can be reduced.

[0071] Alternatively, as shown in FIG. 8, the amount of ink to be discharged from the discharging portions 4b and 4c on both sides of the defective discharging portion 4a, or the number of discharging shots thereby may be alternately

increased in each line of an image to be formed. In this case, printing is performed while print information about the discharging portions 4b and 4c is changed on the basis of the original print information about the defective discharging portion 4a.

[0072] More specifically, print information about the next discharging portions 4b and 4c is changed to indicate that the number of ink droplets to be discharged therefrom is alternately increased so as to form dots having a diameter larger than the diameter of dots 8 formed according to the original print information about the defective discharging portion 4a. As shown in FIG. 8, in the first line L1, dots 8b having a normal diameter are printed by one of the discharging portions 4b, and dots 8c having a diameter larger than the normal diameter are printed by the other discharging portion 4c. In the second line L2, dots 8b having a diameter larger than the normal diameter are printed by the discharging portion 4b, and dots 8c having the normal diameter are printed by the discharging portion 4c. In the third line L3, dots 8b having the normal diameter are printed by the discharging portion 4b, and dots 8c having a diameter larger than the normal diameter are printed by the discharging portion 4c, in a manner similar to that in the first line L1. In the tenth line L10, dots 8b having a diameter larger than the normal diameter are printed by the discharging portion 4b, and dots 8c having the normal diameter are printed by the discharging portion 4c.

[0073] In this way, dots 8b and 8c having a larger diameter are alternately printed from the first line L1 to the tenth line L10 on both sides of a white stripe formed on the recording medium P corresponding to the defective discharging portion 4a. Alternately formed extensions of the dots 8b and 8c alternately cover both sides of the white stripe shown in FIG. 5, and make the white stripe substantially inconspicuous. As a result, image formation on the recording medium P is corrected, and the influence of discharging failure of the defective discharging portion 4a on the image quality can be reduced.

[0074] The above-described correction of image formation on the recording medium P is generally expressed as follows. Herein, A_n represents original print information about the defective discharging portion 4a, and B_n represents corrected print information thereabout. A_{n-1} represents original print information about the left-side discharging portion 4b, and B_{n-1} represents corrected print information thereabout. A_{n+1} represents original print information about the right-side discharging portion 4c, and B_{n+1} represents corrected print information thereabout.

[0075] When correction is made to increase the amount of ink to be discharged from the discharging portion 4b on the left side of the defective discharging portion 4a shown in FIG. 6, or the number of discharging shots therefrom, corrected print information is expressed as follows:

defective discharging portion 4a . . . $B_n=0$ (not discharged)
 left discharging portion 4b . . . $B_{n-1}=(A_{n-1})+A_n$
 right discharging portion 4c . . . $B_{n+1}=A_{n+1}$

[0076] When correction is made to increase the amount of ink to be discharged from the discharging portion 4c on the right side of the defective discharging portion 4a shown in FIG. 6, or the number of discharging shots therefrom, corrected print information is expressed as follows:

defective discharging portion 4a . . . $B_n=0$ (not discharged)
 left discharging portion 4b . . . $B_{n-1}=A_{n-1}$
 right discharging portion 4c . . . $B_{n+1}=(A_{n+1})+A_n$

[0077] When correction is made to increase the amount of ink to be discharged from the discharging portions 4b and 4c on both sides of the defective discharging portion 4a, or the number of discharging shots therefrom, as shown in FIG. 7, corrected print information is expressed as follows:

defective discharging portion 4a . . . $B_n=0$ (not discharged)
 left discharging portion 4b . . . $B_{n-1}=(A_{n-1})+A_n$
 right discharging portion 4c . . . $B_{n+1}=(A_{n+1})+A_n$

[0078] When correction is made to alternately increase the amount of ink to be discharged from the discharging portions 4b and 4c on both sides of the defective discharging portion 4a, or the number of discharging shots in each line, as shown in FIG. 8, corrected print information is expressed as follows:

[0079] (1) Odd line

defective discharging portion 4a . . . $B_n=0$ (not discharged)
 left discharging portion 4b . . . $B_{n-1}=A_{n-1}$
 right discharging portion 4c . . . $B_{n+1}=(A_{n+1})+A_n$

[0080] (2) Even line

defective discharging portion 4a . . . $B_n=0$
 (not discharged)
 left discharging portion 4b . . . $B_{n-1}=(A_{n-1})+A_n$
 right discharging portion 4c . . . $B_{n+1}=A_{n+1}$

[0081] Although not shown, when the amount of ink to be discharged from the discharging portions 4b and 4c on both sides of the defective discharging portion 4a, or the number of discharging shots therefrom is increased according to a given function, corrected print information is expressed as follows:

defective discharging portion 4a . . . $B_n=0$ (not discharged)
 left discharging portion 4b . . . $B_{n-1}=(A_{n-1})+X(A_n)$
 right discharging portion 4c . . . $B_{n+1}=(A_{n+1})+Y(A_n)$

where $X(A_n)$ and $Y(A_n)$ are functions of A_n .

[0082] In any of the above-described corrections, corrected print information (image formation signals) may be differently corrected depending on, for example, characteristics of ink droplets, the type of a recording medium, the image formation mode, the ink color, the size of one ink droplet, or the resolution. For example, in a case in which black ink K having a surface tension higher than those of other inks is used to improve character quality, it is unapt to spread wide on printing paper. Therefore, in order to achieve a better result, image formation should be corrected in consideration of the way of spreading of the ink.

[0083] The above-described corrected print information (image formation signals) may be summarized beforehand in a table, as shown in, for example, FIGS. 9 and 10. FIGS. 9 and 10 show two sections of one print correction table. In the table, corrected print information B_{n-1} , B_n , and B_{n+1} about an odd line and corrected print information B_{n-1} , B_n , and B_{n+1} about an even line are shown corresponding to

original print information A_{n-1} , A_n , and A_{n+1} about a certain line. That is, printing of a line is corrected by two lines corresponding thereto. In the table, the number of ink droplets 3 to be discharged from the discharging portions 4 are shown by, for example, 0 to 8.

[0084] While discharging failure means that not ink droplets 3 are discharged from any of the discharging portions 4 of the print head 1 in the above description, the present invention is not limited to such a case, and is also applicable to a case in which ink droplets 3 discharged from any discharging portion 4 land outside the allowable region on a recording medium P, or to a case in which the amount of ink discharged from any discharging portion 4 is outside the allowable range.

[0085] In a case in which ink droplets 3 discharged from a defective discharging portion 4a land outside the allowable region on a recording medium P, they deviate from a predetermined direction, and a white stripe is formed on the recording medium P corresponding to the defective discharging portion 4a, in a manner similar to that in FIG. 5. In a case in which the amount of ink discharged from a defective discharging portion 4a is outside the allowable range, it is less than a predetermined amount, and a lightly colored portion is formed on the recording medium P corresponding to the defective discharging portion 4a shown in FIG. 5.

[0086] While the amount of ink applied on the recording paper P is controlled by PNM in the above description, in a print head having discharging portions each of which can change the discharging amount of ink, the discharging amount of ink itself may be controlled. Alternatively, the amount of ink may be controlled by a combination of PNM and the method of changing the discharging amount.

[0087] A liquid discharging apparatus as an invention (a second invention of the present invention) relating to the above-described liquid discharging method will now be described with reference to FIG. 11. An image forming apparatus serving as the liquid discharging apparatus is, for example, an ink-jet printer, and forms an image on a recording medium by discharging ink droplets from a plurality of discharging portions of a print head onto the recording medium. The image forming apparatus includes a print head 1, a head driver 10, and an image processing unit 11, as shown in FIG. 11.

[0088] The print head 1 actually discharges ink droplets onto printing paper serving as a recording medium P to print characters and images thereon, and has a plurality of discharging portions 4 provided in a sheet-shaped nozzle member 2 to discharge ink droplets 3, as shown in FIG. 1. Each of the discharging portions 4 includes a discharging outlet 5 formed in the nozzle member 2, and a heating element 6 serving as a driving element for heating and discharging ink in an ink chamber (not shown). A storage section 12 is provided inside the print head 1 to check the discharging states of ink droplets 3 on the basis of actual patterns 9 and 9', which indicate the discharging states of ink droplets 3 from all the discharging portions 4 corresponding to an image forming region of the recording medium P, and to store information about a defective discharging portion, as described with reference to FIGS. 1 and 5.

[0089] The head driver 10 controls the driving of the print head 1 by fetching driving signals from the image process-

ing unit 11, which will be described later, and supplying ON and OFF signals for driving control to the print head 1.

[0090] The image processing unit 11 processes externally input image data, converts the data into head-driving data for driving the print head 1, and sends the converted data to the head driver 10. The image processing unit 11 includes a signal converter 13, a discharging corrector 14, an output converter 15, and a print correction table 16.

[0091] The signal converter 13 receives externally input image data, and converts the image data into multilevel data having a number of colors and a number of levels in accordance with the performance of the overall liquid discharging apparatus by performing, as necessary, data decompression, rasterizing, scaling, color conversion, limitation of the amount of ink, gamma correction, or tone correction such as error diffusion, on the basis of print information such as a selected image formation mode or the type of a recording medium P (printing paper). The print information, such as the image formation mode and the type of printing paper, is sometimes added to a header of the input image data, and is sometimes directly supplied from an input panel (not shown) of the apparatus. In a case in which new print information is not given, the same information as that in the previous print operation, or default information may be used.

[0092] The discharging corrector 14 inputs the multilevel data converted by the signal converter 13, and corrects the data so that the influence of discharging failure of a defective discharging portion 4a (see FIG. 5) hardly appears on the recording medium P, on the basis of information about the defective discharging portion 4a read from the storage section 12 in the print head 1 (e.g., the position of the defective discharging portion 4a and the type of discharging failure) and print information (image formation signals) read from the print correction table 16 which will be described later. A memory 17 is provided in the discharging corrector 14 to store discharging information read from the storage section 12. This allows the discharging information to be read from the storage section 12 and stored in the memory 17 when the print head 1 is mounted or the power is turned on. Therefore, the discharging information does not need to be read from the storage section 12 in every operation, and can be normally read from the memory 17.

[0093] The output converter 15 functions as an output converting means for converting multilevel data corrected by the discharging corrector 14 into driving signals for the head driver 10. The output converter 15 converts the multilevel data into ON and OFF signals for actually driving the head driver 10.

[0094] The print correction table 16 lists and stores new image formation signals corrected to reduce the influence of discharging failure on the basis of original image formation signals for the defective discharging portion 4a and the discharging portions 4b and 4c on both sides thereof (see FIG. 5), as described with reference to FIGS. 9 and 10.

[0095] The liquid discharging apparatus having such a configuration operates in a manner similar to that in the liquid discharging method described with reference to FIGS. 1 and 5 to 8. That is, first, the print head 1 is driven under the control of the head driver 10 shown in FIG. 11, and an actual pattern 9 or 9' that indicates the discharging

states of ink droplets 3 from all the discharging portions 4 in the print head 1 corresponding to an image forming region on a recording medium P is printed on the recording medium P.

[0096] When ink droplets 3 are normally discharged from all the discharging portions 4, an actual pattern 9 is printed on the recording medium P, for example, in which pattern dots 8 are solidly formed by ink droplets 3 from the first line L1 to the tenth line L10, as shown in FIG. 1. In contrast, when any of the discharging portions 4a is defective, an actual pattern 9' is printed on the recording medium P, in which ink does not adhere at all or adheres insufficiently corresponding to the defective discharging portion 4a, and a white stripe or a lightly colored portion is formed from the first line L1 to the tenth line L10, as shown in FIG. 5. FIG. 5 shows a case in which no ink droplet 3 is discharged from the defective discharging portion 4a (undischarged).

[0097] Then, the discharging states of ink droplets 3 are checked on the basis of the printed actual pattern 9', and information about the defective discharging portion 4a is stored in the storage section 12 in the print head 1 shown in FIG. 11. The information includes, for example, print information such as the position of the defective discharging portion 4a, the discharging amount of ink, and the number of discharging shots. The information is recorded in, for example, shipping inspections.

[0098] During actual printing on the recording medium P, the discharging corrector 14 in the image processing unit 11 shown in FIG. 11 reads out the information about the defective discharging portion 4a from the storage section 12 in the print head 1, and prohibits the defective discharging portion 4a from discharging ink droplets 3. Subsequently, on the basis of the information about the defective discharging portion 4a and corrected print information (image formation signals) read from the print correction table 16, the discharging corrector 14 controls the discharging of ink droplets 3 from the discharging portions 4b and 4c near the defective discharging portion 4a so that the influence of discharging failure of the defective discharging portion 4a hardly appears on the recording medium P.

[0099] In this state, the corrected print information is converted into driving signals by the output converter 15, and is sent to the head driver 10. The head driver 10 supplies the input driving signals to the print head 1 to control an actual printing operation on the recording medium P. Consequently, discharging of ink droplets 3 from the discharging portions 4 in the print head 1 is controlled, as shown in, for example, FIGS. 6, 7, or 8, and image formation on the recording medium P is corrected. Therefore, the influence of discharging failure of the defective discharging portion 4a on the image quality can be reduced, and the print head 1 is allowed to be used even when any of the discharging portions 4 is defective. As a result, the production yield of the print head 1 can be enhanced.

[0100] While the storage section 12 is provided inside the print head 1 in FIG. 11, it may be provided inside the image processing unit 11. Alternatively, the storage section 12 may be provided inside an external control unit such as a host computer, or may be provided inside some or all of the print head 1, the image processing unit 11, and the external control unit.

[0101] A specific example of the above-described liquid discharging apparatus, for example, an ink-jet printer will

now be described with reference to FIG. 12 as a partly cutaway perspective view and FIG. 13 as a sectional side view. An ink-jet printer 20 of this example is provided with a line head 22 that has unshown heating elements (reference numeral 6 in FIG. 1) as driving elements for discharging ink droplets (reference numeral 3 in FIG. 1). The recording range of the ink-jet printer 20 is substantially equal to the width of sheets of paper 21. The ink-jet printer 20 adopts a so-called PNM (Pulse Number Modulation) method for changing the diameter and density of dots (reference numeral 8 in FIG. 2) by the number of ink droplets.

[0102] As shown in FIGS. 12 and 13, the ink-jet printer 20 includes, in a housing 23, the line head 22, a paper feeding section 24, a paper delivery section 25, a paper tray 26, an electric circuit section 27, and so on. The housing 23 is shaped like a rectangular parallelepiped. A paper ejection slot 28 for sheets of paper 21 is provided in one end face of the housing 23, and a tray loading opening 29 for the paper tray 26 is provided in the other end face thereof.

[0103] The line head 22 includes head sections for four colors, yellow Y, magenta M, cyan C, and black K, and is disposed in the upper part of an end portion of the housing 23 adjacent to the paper ejection slot 28 so that discharging outlets (reference numeral 5 in FIG. 1) for discharging ink droplets face downward. That is, as described above, the line head 22 is constructed by four elongated ink discharging means for Y, M, C, and K that are arranged in the feeding direction of the sheets of paper 21.

[0104] The paper feeding section 24 includes a feeding guide 30, feeding rollers 31 and 32, a feeding motor 33, pulleys 34 and 35, and belts 36 and 37, and is disposed in the lower part of the end portion of the housing 23 adjacent to the paper ejection slot 28. The feeding guide 30 is shaped like a flat plate, and is disposed below the line head 22 with a predetermined space therebetween. Each of the feeding rollers 31 and 32 is composed of a pair of upper and lower rollers in contact with each other, and are disposed on both sides of the feeding guide 30, that is, on the sides of the tray loading opening 29 and the paper ejection slot 28. The feeding motor 33 is disposed below the feeding guide 30, and is linked to the feeding rollers 31 and 32 through the pulleys 34 and 35 and the belts 36 and 37.

[0105] The paper delivery section 25 includes a delivery roller 38, a delivery motor 39, and gears 40, and is disposed on a side of the paper feeding section 24 close to the tray loading opening 29. The delivery roller 38 is substantially semicylindrical, and is disposed adjacent to the feeding roller 31 on the side of the tray loading opening 29. The delivery motor 39 is disposed above the delivery roller 38, and is linked to the delivery roller 38 through the gears 40.

[0106] The paper tray 26 is shaped like a box that can accommodate, for example, a plurality of stacked A4-sized sheets of paper 21. A paper support 42 is supported by a spring 41 at one end of the bottom face of the paper tray 26, and extends from below the delivery section 25 toward the tray loading opening 29. The electric circuit section 27 is disposed above the paper tray 26 to control the driving of the components.

[0107] The use and basic operation of the ink-jet printer 20 having such a configuration will be described briefly. A user draws the paper tray 26 from the tray loading opening 29,

puts a predetermined number of sheets of paper **21** into the paper tray **26**, and then pushes the paper tray **26**. Then, the paper support **42** raises and presses one end of the paper **21** against the delivery roller **38** by the action of the spring **41**. This brings about a print standby state.

[0108] When a print start signal is given, the delivery roller **38** is rotated by the delivery motor **39** to deliver one sheet **21** from the paper tray **26** to the feeding roller **31**. Subsequently, the feeding rollers **31** and **32** are rotated by the feeding motor **33**, and the feeding roller **31** feeds the delivered sheet **21** to the feeding guide **30**. Then, the line head **22** operates at a predetermined timing according to print data, and discharges ink droplets from discharging outlets onto the sheet **21** to print characters and images formed by dots. Next, the feeding roller **32** ejects the fed sheet **21** from the paper ejection slot **28**.

[0109] The ink-jet printer **20** having such a configuration operates in a manner similar to that in the image forming method that has been described with reference to **FIGS. 1 and 5 to 8**.

[0110] Third, fourth, and fifth inventions will now be described.

[0111] **FIG. 14** is a general view showing a liquid discharging method according to an embodiment of the present invention. In the liquid discharging method, dots **D** or arrays of dots **D** are formed by discharging droplets from a plurality of discharging portions (not shown) in a head **110** while controlling the discharging direction.

[0112] The discharging states of ink droplets discharged from the discharging portions are checked, and information about a defective discharging portion is obtained. The defective discharging portion is prohibited from discharging, and droplets are discharged from the other discharging portions while controlling the discharging direction, thereby reducing the influence of discharging failure of the defective discharging portion. A specific configuration for carrying out the method will now be described in detail.

[0113] **FIG. 15** is an exploded perspective view of a print head **110** in an ink-jet printer serving as an apparatus that is directly used to carry out the liquid discharging method of this invention. A nozzle member **170**, which will be described later, is bonded to a barrier layer **160**, as shown in **FIG. 15**. In **FIG. 15**, the nozzle member **170** is separately shown.

[0114] The print head **110** is of a so-called thermal type in which a bubble is generated by heating ink in an ink chamber **120** with heating resistors **130** and the ink is discharged by the energy resulting from the generation of the bubble. The print head **110** includes a base member **140**, the barrier layer **160**, and the nozzle member **170**. The base member **140** includes a semiconductor substrate **150** made of silicon or the like, and heating resistors **130** (corresponding to heating elements in the present invention) precipitated on one surface of the semiconductor substrate **150**. The heating resistors **130** are electrically connected to an external circuit through a conductive portion (not shown) formed on the semiconductor substrate **150**.

[0115] The barrier layer **160** is formed, for example, by applying a photocurable dry film resist on the overall surface

of the semiconductor substrate **150** with the heating resistors **130**, and removing unnecessary portions therefrom by a photolithographic process.

[0116] The nozzle member **170** has a plurality of nozzles (discharging outlets) **180**, and is formed by, for example, nickel electroforming. The nozzle member **170** is bonded on the barrier layer **160** so that the nozzles **180** are aligned with the heating resistors **130**, that is, so that the nozzles **180** oppose the heating resistors **130**.

[0117] The ink chamber **120** is defined by the base member **140**, the barrier layer **160**, and the nozzle member **170** so as to surround the heating resistors **130**. That is, in **FIG. 15**, the base member **150**, the barrier layer **160**, and the nozzle member **170** form, respectively, a bottom wall, a side wall, and a top wall of the ink chamber **120**. Accordingly, the ink chamber **120** has an open face on the right front side in **FIG. 15**, and the open face communicates with an ink channel (not shown).

[0118] The single print head **110** normally includes a plurality of (hundreds of) heating resistors **130**, and ink chambers **120** containing the heating resistors **130**. In response to a command from a control unit in the printer, the heating resistors **130** are selectively operated to discharge ink in the ink chambers **120** corresponding thereto from the nozzles **180** opposing the ink chambers **120**.

[0119] That is, ink is supplied from an ink tank (not shown) connected to the print head **110** into each ink chamber **120**. By passing a pulse current through a heating resistor **130** in the ink chamber **120** for a short period, for example, 1 μ sec to 3 μ sec, the heating resistor **130** is rapidly heated. As a result, a bubble is produced in a part of the ink in contact with the heating resistor **130**, and a certain volume of ink is pushed away by expansion of the bubble (ink boils). Consequently, a part of the ink, which has a volume equivalent to that of the pushed ink and is in contact with the nozzle **180**, is discharged as a droplet from the nozzle **180** onto printing paper to form a dot.

[0120] In the following description, a “discharging portion” refers to a portion constituted by an ink chamber **120**, a heating resistor **130** disposed inside the ink chamber **120**, and a nozzle **180** disposed on the ink chamber **120**. That is, the print head **110** shown in **FIG. 15** has a plurality of discharging portions arranged side by side.

[0121] The print head **110** has a discharging-direction deflecting means for controlling the discharging direction of ink droplets. The discharging-direction deflecting means deflects the discharging direction of an ink droplet discharged from a nozzle **180** so that the ink droplet can land on or adjacent to a landing position of an ink droplet that is discharged from an adjacent nozzle **180** without being deflected. The discharging-direction deflecting means has the following structure.

[0122] **FIGS. 16A and 16B** are a plan view and a sectional side view, respectively, showing the arrangement of the heating resistors **130** in the print head **110** in more detail. In **FIG. 16A**, the nozzle **180** is shown by one-dot chain lines.

[0123] In the print head **110** of this embodiment, two heating resistors **130** are disposed side by side in one ink chamber **120**, as shown in **FIGS. 16A and 16B**. That is, one ink chamber **120** includes two split heating resistors **130**.

The heating resistors **130** are arranged in the same direction as the direction in which the nozzles **180** are arranged (right-left direction in the figures).

[0124] In a case in which one heating resistor is vertically split into two heating resistors **130** in this way, the length is not changed, but the width is halved. Therefore, the resistance of the heating resistors **130** is doubled. By connecting the two split heating resistors **130** having the double resistance in series, the resistance is quadrupled.

[0125] In order to boil ink in the ink chamber **120**, the heating resistor **130** is needed to be heated by the application of a given current. This is because ink is discharged by the energy of boiling. Although a large current must be applied when the resistance is low, ink can be boiled with a small current by increasing the resistance of the heating resistor **130**, as described above.

[0126] Consequently, the size of a transistor for applying a current can be reduced, and space saving can be achieved. While the resistance can be increased by reducing the thickness of the heating resistor **130**, such thickness reduction is limited from the viewpoints of material and strength (durability) of the heating resistor **130**. For this reason, the resistance is increased by splitting the heating resistor without reducing the thickness.

[0127] In a case in which two split heating resistors **130** are provided in one ink chamber **120**, ink simultaneously boils on the two heating resistors **130** by causing the heating resistors **130** to reach the temperature for boiling ink in the same time (bubble generation time). This allows an ink droplet to be discharged in the direction of the center axis of the nozzle **180**.

[0128] In contrast, when the bubble generation time is different between the two heating resistors **130**, ink does not simultaneously boil thereon. In this case, a discharged ink droplet deviates from the center axis of the nozzle **180**. Therefore, the ink droplet lands offset from the landing position of an ink droplet discharged without being deflected.

[0129] FIG. 17 is a graph showing the relationship between the difference in bubble generation time between the two split heating resistors **130** shown in FIGS. 16A and 16B, and the discharging angle of ink droplets in the X-direction. FIG. 18 is a graph showing the relationship between the difference in bubble generation time, and the discharging angle of ink droplets in the Y-direction. Values in the graphs of FIGS. 17 and 18 are obtained by computer simulation. In these graphs, the X-direction refers to a direction in which the nozzles **180** are arranged (the heating resistors **130** are arranged side by side), and the Y-direction refers to a direction perpendicular to the X-direction (feeding direction of printing paper P). In both the X- and Y-directions, the angle shows the amount of offset of a discharged ink droplet from 0° serving as a direction at which the ink droplet is discharged without being deflected.

[0130] As shown in FIGS. 17 and 18, when there is a difference in bubble generation time between the heating resistors **130**, the discharging angle of ink droplets deviates. Accordingly, in this embodiment, this characteristic is utilized. That is, the discharging angle of ink droplet is deviated by forming a difference in bubble generation time between the heating resistors **130**, thereby controlling the discharging direction.

[0131] With reference to FIG. 19, a description will be given of what degree to which the discharging angle of ink droplets can be adjusted. FIG. 19 is a sectional side view showing the relationship between the discharging angle of ink droplets **60** from the nozzles **180** of the nozzle member **170**, and printing paper P. In FIG. 19, the distance H between the leading ends of the nozzles **180** and the printing paper P is approximately b 1 mm to 2 mm in normal ink-jet printers.

[0132] When the resolution of the print head **110** is set at 600 dpi, the landing interval (dot interval) of the ink droplets **60** is given as follows:

$$25.40 \times 1000 / 600 \approx 42.3 \text{ (}\mu\text{m)}$$

[0133] In such a print head **110**, the discharging direction of ink droplets **60** from each nozzle **180** is changed, for example, in eight steps by deflecting the discharging angle of the ink droplets **60**. When it is assumed that ink droplets **60** are vertically discharged from eight adjoining nozzles **180**₁, **180**₂, . . . , **180**₈ provided in the nozzle member **170** without deflecting the discharging angle, and that positions on the printing paper P on which the ink droplets **60** land are designated D₁ to D₈, the discharging direction is changed so that ink droplets **60** discharged from each nozzle **180**, for example, a nozzle **180**₄, land on the eight landing positions D₁ to D₈ on the printing paper P.

[0134] By thus discharging ink droplets **60** from a plurality of discharging portions (not shown) of the print head **110** while changing the discharging direction, as shown in FIGS. 14(a) to 14(h), the ink droplets **60** are caused to land on the printing paper P to form dots D or dot arrays D, as shown in FIG. 14(i). The discharging angle shown in FIG. 14(a) is designated deg1, and the discharging angle in FIG. 14(b) is designated deg2. The discharging angles in subsequent figures are similarly designated, and the discharging angle in FIG. 14(h) is designated deg8.

[0135] The above-described print head **110** is a line head that adopts the above-described PNM method, as shown in FIG. 20. The print head **110** includes head sections for four colors, yellow Y, magenta M, cyan C, and black K, and is disposed so that the nozzles **180** for discharging ink droplets **60** face downward.

[0136] For plain explanation, a description will be given of a case in which, for example, only cyan ink is used without using yellow, magenta, and black inks. A maximum of seven droplets of one color can be discharged from each discharging portion, and six or less droplets are discharged to print one dot D on the printing paper P. The number of droplets that form one cyan dot can be changed from zero to eight by the PNM method, as described above. The amount of ink to be discharged is set at, for example, 3.5 pl.

[0137] In the following description, ink droplets **60** are discharged in response to PNM signals serving as droplet discharging signals. A driving timing for the first ink droplet **60** discharged from each discharging portion is designated PNM1, and a driving timing for the second ink droplet **60** is designated PNM2. Subsequent timings are similarly designated, and a driving timing for the seventh ink droplet **60** is designated PNM7.

[0138] In such a state, as shown in FIG. 20(a), ink droplets **60** are discharged from a nozzle **180** of the print

head **110** onto printing paper P serving as a recording medium. In this case, the discharged ink droplets **60** spread in the directions S to form one dot D, as shown in **FIG. 20(b)**. Therefore, the size of the dot D gradually increases depending-on the number of the ink droplets **60**. **FIG. 21** shows the relationship between the number of droplets and the dot diameter. The dot diameter increases from approximately 38 μm to approximately 79 μm as the number of droplets increases from 1 to 7. When the number of droplets is four, as shown in **FIG. 21A**, the dot diameter is approximately 63 μm .

[0139] With reference to **FIG. 22**, a description will be given of a liquid discharging method in which dots D or dot arrays are formed by discharging ink droplets **60** from the discharging portions of the print head **110** while changing the discharging direction and while changing the diameter of the dots D by the number of ink droplets **60**. **FIG. 22** is a table showing the relationship between dots D (D_1 to D_9) formed by PNM, and the discharging portions for discharging ink droplets **60** to form the dots D. In a known type of a print head **310** that does not change the discharging direction of ink droplets (see **FIG. 25**), ink droplets **60** are discharged from the same discharging portions from the driving timing PNM1 to the driving timing PNM7.

[0140] In contrast, in the liquid discharging method of this invention, ink droplets are discharged from different discharging portions to form each dot D, as shown in **FIG. 22**. That is, as shown in **FIG. 14**, ink droplets **60** are continuously discharged from a plurality of discharging portions (not shown) provided in the print head **110** while changing the discharging direction. The first ink droplets **60** are discharged at the discharging angle $\text{deg}1$ (see **FIG. 14(a)**), and the second ink droplets **60** are discharged at the discharging angle $\text{deg}2$ (see **FIG. 14(b)**). Subsequently, ink droplets **60** are similarly discharged from different discharging portions to form one dot D, thereby changing the dot diameter by PNM.

[0141] More specifically, for example, in order to form a dot D_1 in the A-th line, an ink droplet is discharged from the discharging portion (nozzle) 180_1 shown in **FIG. 19** (hereinafter, the discharging portion 180_1 will be abbreviated as "DP1" in the table of **FIG. 22**, other discharging portions are similarly abbreviated) at a driving timing PNM1, an ink droplet is discharged from DP-1 on the left side of the DP1 (on the left side in **FIG. 19**, nozzle number is not shown) at PNM2, and an ink droplet is discharged from DP-2 on the left side of DP-1 at PNM3, as shown in **FIG. 22**. Subsequently, similar discharging is performed, and an ink droplet is discharged from DP-6 at PNM7. In this way, ink droplets are discharged from the different discharging portions at the driving timings PNM1 to PNM7, so that a dot D_1 in the A-th line is formed.

[0142] In order to form a dot D_1 in the next B-th line, an ink droplet is discharged from DP-7 at PNM1, and an ink droplet is discharged from DP1 at PNM2, in a manner different from that in the above-described dot D_1 in the A-th line. Subsequently, discharging is similarly performed, and an ink droplet is discharged from DP-5 at PNM7. In this way, the cycle in which the discharging portions are interchanged does not correspond to the PNM cycle.

[0143] In a case in which the cycles correspond to each other, for example, when discharging at the driving timing

PNM1 continues, an array of dots D from the dot D_1 in the A-th line to the dot D_1 in the F-th line are formed by ink droplets discharged from the same discharging portion, and a white stripe **330** (see **FIG. 26**) is likely to appear on the printing paper P.

[0144] In the above-described liquid discharging method in which dot arrays or dots are formed by discharging ink droplets from the discharging portions of the print head **110** while changing the discharging direction, first, an actual pattern that indicates the discharging states of ink droplets **60** from all the discharging portions is formed. For example, an actual pattern is printed on printing paper P by discharging ink droplets **60** from the discharging portions in the above-described PNM method without deflecting the discharging direction. In this case, when the ink droplets **60** are normally discharged from all the discharging portions, a normal pattern is formed in an image forming region of the printing paper P, although not shown.

[0145] In contrast, when any of the discharging portions is defective, ink does not adhere or insufficiently adheres to the printing paper P, and therefore, a pattern including white stripes **330** (see **FIG. 26**) or lightly colored portions is formed.

[0146] Information about the defective discharging portion is obtained by checking the actual pattern (not shown) for the discharging states of ink droplets **60**. That is, it is determined, on the basis of the actual pattern formed by the above-described manner, whether a defective discharging portion exists. When it is determined that a defective discharging portion exists, information about, for example, the position of the defective discharging portion, the amount of discharged ink, and the number of discharging shots, is obtained. For example, when it is assumed that the nozzle 180_1 (discharging portion **1**) shown in **FIG. 19** is judged defective, the influence of discharging failure appears at the driving timing PNM1 for a dot D_1 in the A-th line in **FIG. 22**, the driving timing PNM2 for a dot D_2 in the A-th line, the driving timing PNM3 for a dot D_3 in the A-th line, . . . , and the driving timing PNM1 for a dot D_8 in the B-th line, and so on. In this case, lightly colored portions **350** shaped like stripes remain in a printed image (see **FIG. 27**), and this reduces the quality of the printed image.

[0147] The obtained information about the defective discharging portion **1** is stored in a storage section provided inside the print head **110** or inside an image processing unit **210** (**FIG. 24**) which will be described later, or is stored in a storage section provided inside an external control unit such as a host computer. Alternatively, the information may be stored in storage sections provided in some of the print head **110**, the image processing unit **210**, and the external control unit.

[0148] According to the information, the defective discharging portion **1** is prohibited from discharging, new droplet discharging signals are generated to reduce the influence of discharging failure of the defective discharging portion **1**. By continuously discharging ink droplets from a nozzle **180** (**FIG. 19**) different from the defective discharging portion **1** while controlling the discharging direction according to the new droplet discharging signals, the diameter of dots D is changed to reduce the influence of discharging failure of the defective discharging portion **1**. In this case, since it is determined that the nozzle 180_1 (dis-

charging portion 1) shown in FIG. 19 is defective, the defective discharging portion 1 is prohibited from discharging, and ink droplets 60 are discharged from a discharging portion different from the defective discharging portion 1 according to new droplet discharging signals that is generated with reference to a correction table shown in FIG. 23.

[0149] FIG. 23 shows a correction table that lists new droplet discharging signals to be generated to remove the influence of discharging failure of a defective discharging portion, and is created beforehand. FIG. 23 shows a case in which the discharging portion 1 shown in FIG. 22 is defective. As shown in FIG. 23, droplet discharging signals (PNM1 to PNM7) for dots D_1 to D_8 from the A-th to F-th lines are changed in order to resolve the influence of discharging failure of the defective discharging portion.

[0150] More specifically, for example, in order to form a small-diameter dot D_1 in the A-th line by discharging only one ink droplet 60 at the driving timing PNM1, the droplet discharging signal is changed from PNM1 to PNM2, as shown in FIG. 23. Consequently, an attempt is made to discharge an ink droplet 60 from the discharging portion 1 at the driving timing PNM1, and an ink droplet 60 is discharged from the discharging portion -1 at the driving timing PNM2. Since the defective discharging portion 1 is prohibited from discharging, as described above, in actuality, only one ink droplet 60 is discharged from the discharging portion -1, and a small-diameter dot D can be formed.

[0151] For example, in order to form a small-diameter dot D_2 in the A-th line by discharging only one ink droplet 60 at the driving timing PNM1, the droplet discharging signal remains PNM1. In this case, a dot is formed by discharging only one ink droplet 60 from the discharging portion 2, which is not defective, at the driving timing PNM1, as shown in FIG. 22.

[0152] In contrast, in order to form a dot D_2 in the A-th line by discharging two ink droplets 60 at the driving timing PNM2, the droplet discharging signal is changed from PNM2 to PNM3, as shown in FIG. 23. Consequently, an ink droplet 60 is discharged from the discharging portion 2 at the driving timing PNM1, an attempt is made to discharge an ink droplet 60 from the discharging portion 1 at the driving timing PNM2, and an ink droplet 60 is discharged from the discharging portion -1 at the driving timing PNM3, as shown in FIG. 22. Since the defective discharging portion 1 is prohibited from discharging, as described above, in actuality, a dot D can be formed by discharging two ink droplets 60 from the discharging portions 2 and -1 to form a dot D.

[0153] Since dots D_9 from the A-th to F-th lines are formed without discharging ink droplets from the defective discharging portion 1, as shown in FIG. 22, droplet discharging signals (PNM1 to PNM7) are not changed. As described above, the influence of discharging failure of the defective discharging portion can be resolved by continuously discharging ink droplets 60 from a discharging portion different from the defective discharging portion 1 while changing the discharging direction according to new droplet discharging signals generated with reference to the correction table shown in FIG. 23. In this case, lightly colored portions (see FIG. 27) do not remain on a print image, and a high-quality print image can be formed.

[0154] While the reduction in quality of a print image is prevented by removing the influence of discharging failure

of the defective discharging portion at all the driving timings PNM1 to PNM7 in the correction table shown in FIG. 23, correction may be made when the influence is particularly prominent. That is, new droplet discharging signals may be generated with reference to the correction table only when the diameter of a dot formed by ink droplets discharged from a discharging portion different from the defective discharging portion takes the minimum value or is close to the minimum value, for example, at the driving timing PNM1 or PNM2.

[0155] While discharging failure means that no ink droplets 60 are discharged from any of the discharging portions of the print head 110 in the above description, the present invention is not limited to such a case, and is also applicable to a case in which ink droplets 60 discharged from any discharging portion land outside the allowable region on printing paper P, or to a case in which the amount of ink discharged from any discharging portion is outside the allowable range.

[0156] In a case in which ink droplets 60 discharged from a defective discharging portion land outside the allowable region on printing paper P, they deviate from a predetermined direction, and lightly colored portions are formed in a print image, in a manner similar to that in FIG. 27. In a case in which the amount of ink discharged from a defective discharging portion is outside the allowable range, it is less than a predetermined amount, and lightly colored portions are formed on the printing paper P, although not shown.

[0157] While the amount of ink is controlled by discharging ink droplets 60 with PNM in the above description, in a print head having discharging portions each of which can change the discharging amount of ink, the discharging amount of ink itself may be controlled, or the amount of ink may be controlled by a combination of PNM and the method of changing the discharging amount.

[0158] A description will be given of a liquid discharging apparatus relating to the above-described liquid discharging method as inventions relating to the above-described liquid discharging method (sixth, seventh, and eighth inventions), with reference to FIG. 24. An image forming apparatus serving as the liquid discharging apparatus is, for example, an ink-jet printer, and forms a print image on a recording medium by discharging ink droplets from a plurality of discharging portions provided in a print head onto the recording medium while changing the discharging direction. Referring to FIG. 24, the image forming apparatus includes a print head 110, a head driver 200, and an image processing unit 210.

[0159] The print head 110 actually discharges ink droplets onto printing paper P serving as a recording medium to print characters and images thereon, and has a plurality of discharging portions provided in a sheet-shaped nozzle member 170 to discharge ink droplets 60, as shown in FIG. 15. Each of the discharging portions includes a nozzle (discharging outlet) 180 formed in the nozzle member 170, and a heating element 130 serving as a driving element for heating and discharging ink in an ink chamber (not shown). A storage section 220 is provided inside the print head 110 to check an actual pattern which indicates the discharging states of ink droplets 60 from all the discharging portions, and to store information about a defective discharging portion.

[0160] The head driver 200 controls the driving of the print head 110 by fetching driving signals from the image

processing unit **210**, which will be described later, and supplying ON and OFF signals for driving control to the print head **110**.

[0161] The image processing unit **210** processes externally input image data, converts the data into head-driving data for driving the print head **110**, and sends the converted data to the head driver **200**. The image processing unit **210** includes a signal converter **230**, a discharging corrector **240**, an output converter **250**, and a print correction table **260**.

[0162] The signal converter **230** receives externally input image data, and converts the image data into multilevel data having a number of colors and a number of levels in accordance with the performance of the overall liquid discharging apparatus by performing, as necessary, data decompression, rasterizing, scaling, color conversion, limitation of the amount of ink, gamma correction, or tone correction such as error diffusion, on the basis of print information such as a selected image formation mode or the type of a recording medium (printing paper P). The print information, such as the image formation mode and the type of printing paper, is sometimes added to a header of the input image data, and is sometimes directly supplied from an input panel (not shown) of the apparatus. In a case in which new print information is not given, the same information as that in the previous print operation or default information may be used.

[0163] The discharging corrector **240** inputs the multilevel data converted by the signal converter **230**, and corrects the data so that the influence of discharging failure of a defective discharging portion **1** (see FIG. 22) hardly appears on the printing paper P, on the basis of information about the defective discharging portion **1** read from the storage section **220** in the print head **110** (e.g., the position of the defective discharging portion **1** and the type of discharging failure) and print information (image formation signals) read from the print correction table **260** which will be described later. A memory **270** is provided in the discharging corrector **240** to store discharging information read from the storage section **220**. This allows the discharging information to be read from the storage section **220** and stored in the memory **270** when the print head **110** is mounted or the power is turned on. Therefore, the discharging information does not need to be read from the storage section **220** in every operation, and can be normally read from the memory **270**.

[0164] The output converter **250** functions as an output converting means for converting multilevel data corrected by the discharging corrector **240** into driving signals for the head driver **200**. The output converter **250** converts the multilevel data into ON and OFF signals for actually driving the head driver **200**.

[0165] The print correction table **260** lists and stores new droplet discharging signals generated to reduce the influence of discharging failure of the defective discharging portion, as described with reference to FIGS. 22 and 23.

[0166] The liquid discharging apparatus having such a configuration operates in a manner similar to that in the liquid discharging method described with reference to FIGS. 14 to 23. That is, first, the print head **110** is driven under the control of the head driver **200** shown in FIG. 24, and an actual pattern (not shown) that indicates the discharging states of ink droplets **60** from all the discharging portions **4**

in the print head **110** corresponding to an image forming region on the printing paper P is printed on the printing paper P by discharging ink droplets **60** in the above-described PNM method without deflecting the discharging direction.

[0167] When ink droplets **60** are normally discharged from all the discharging portions, a normal pattern is printed on in the image forming region on the printing paper P, although not shown. In contrast, when any of the discharging portions is defective, a pattern is printed on the printing paper P, in which ink does not adhere at all or adheres insufficiently corresponding to the defective discharging portion, and white stripes **330** (see FIG. 26) or lightly colored portions are formed.

[0168] Then, the discharging states of ink droplets **60** are checked on the basis of the printed actual pattern, and information about the defective discharging portion is stored in the storage section **220** in the print head **110** shown in FIG. 24. The information includes, for example, print information such as the position of the defective discharging portion, and the discharging amount of ink. The information is recorded in, for example, shipping inspections.

[0169] During actual printing on the printing paper P, the discharging corrector **240** in the image processing unit **210** shown in FIG. 24 reads out the information about the defective discharging portion **1** (see FIG. 22) from the storage section **110** in the print head **110**, and prohibits the defective discharging portion **1** from discharging ink droplets. Subsequently, on the basis of the information about the defective discharging portion **1** and corrected print information (droplet discharging signals serving as image formation signals) read from the print correction table **160**, the discharging corrector **240** controls the discharging of ink droplets **60** from discharging portions different from the defective discharging portion **1** so that the influence of discharging failure of the defective discharging portion **1** hardly appears on the printing paper P.

[0170] In this state, the corrected print information is **25015**, and is sent to the head driver **200**. The head driver **200** supplies the input driving signals to the print head **110** to control an actual printing operation on the printing paper P. Consequently, as described with reference to FIGS. 22 and 23, ink droplets **60** are discharged from the discharging portions different from the defective discharging portion **1** while changing the discharging direction according to the print information as new droplet discharging signals, the influence of discharging failure of the defective discharging portion is resolved, and a print image on the printing paper P is corrected. Therefore, the influence of discharging failure on the image quality can be removed, and the print head **110** can be used even when any of the discharging portions is defective. As a result, the production yield of the print head **110** can be enhanced.

[0171] While the storage section **220** is provided inside the print head **110** in FIG. 24, it may be provided inside the image processing unit **210**. Alternatively, the storage section **220** may be provided inside an external control unit such as a host computer, or may be provided inside some or all of the print head **110**, the image processing unit **210**, and the external control unit.

[0172] The above-described image forming apparatus, such as an ink-jet printer, serving as the liquid discharging

apparatus can be achieved by applying the image forming method described with reference to FIGS. 14 to 23 to the ink-jet printer shown in FIGS. 12 and 13.

[0173] While the embodiments corresponding to the fourth, fifth, sixth, seventh, and eighth inventions have been described above, it is to be understood that the invention is not limited to the disclosed embodiments. On the contrary, the invention is intended to cover various modifications and equivalent arrangements included within the spirit and scope of the appended claims. For example, while a difference is formed in the time in which ink droplets boil on the two split heating resistors 130 (bubble generation time) between the heating resistors 130 by varying the current to be passed through the heating resistors 130, in addition, a difference may be formed in the time in which a current is passed through the two heating resistors 130.

[0174] In the above embodiments, two split heating resistors 130 are arranged side by side in one ink chamber 120 because it is sufficiently verified that such splitting into two ensures endurance, and the circuit configuration can be simplified. However, three or more heating resistors 130 may be arranged side by side in one ink chamber 120.

[0175] While the printer head and the line head in the above embodiments are used in printers, they may be applied not only to the printers, but also to various liquid discharging apparatuses. For example, the heads may be applied to an apparatus that discharges a DNA-containing solution in order to detect biological samples. Furthermore, the heating resistors 130 in the embodiments may be replaced with heating elements other than resistors.

1. A liquid discharging method for discharging droplets from a plurality of liquid discharging portions, the method comprising the steps of:

discharging droplets from the liquid discharging portions to form an actual pattern;

obtaining information about a defective liquid discharging portion having discharging failure by checking the actual pattern for the discharging states of the droplets from the liquid discharging portions; and

prohibiting the defective liquid discharging portion from discharging, and controlling discharging of droplets from a liquid discharging portion near the defective liquid discharging portion by changing the number of discharging shots from a liquid discharging portion disposed on one side of the defective liquid discharging portion.

2. A liquid discharging method according to claim 1, wherein the discharging failure means that no droplets are discharged from the defective liquid discharging portion.

3. A liquid discharging method according to claim 1, wherein the discharging failure means that the discharging direction from the defective liquid discharging portion deviates from an allowable range.

4. A liquid discharging method according to claim 1, wherein the discharging failure means that the amount of liquid in the droplets discharged from the defective liquid discharging portion is outside an allowable range.

5. (canceled)

6. A liquid discharging method according to any one of claims 2 to 4, wherein the discharging of the droplets from the liquid discharging portion near the defective liquid

discharging portion is controlled by changing the number of discharging shots from liquid discharging portions disposed on both sides of the defective liquid discharging portion.

7. A liquid discharging method according to any one of claims 2 to 4, wherein the discharging of the droplets from the liquid discharging portion near the defective liquid discharging portion is controlled by alternately changing the discharging amount of liquid from liquid discharging portions disposed on both sides of the defective liquid discharging portion, or the number of discharging shots therefrom every time one line is formed.

8. A liquid discharging method according to any one of claims 2 to 4, wherein the discharging of the droplets from the liquid discharging portion near the defective liquid discharging portion is controlled by discharging the droplets according to new droplet discharging signals that are generated on the basis of original liquid discharging signals for the defective liquid discharging portion and liquid discharging portions on both sides thereof in order to reduce the influence of the discharging failure of the defective liquid discharging portion.

9. A liquid discharging method according to claim 8, wherein the new liquid discharging signals depend on the characteristics of the droplets, the type of a recording medium, or an image formation mode.

10. A liquid discharging method according to claim 8, wherein the new liquid discharging signals are listed in a table beforehand.

11. A liquid discharging apparatus for forming an image on a recording medium by discharging droplets from a plurality of liquid discharging portions onto the recording medium, the apparatus comprising:

a liquid discharging head having the liquid discharging portions;

a head driver for controlling the driving of the liquid discharging head;

an image processing unit that converts externally input image data into head driving data for driving the liquid discharging head and sends the head driving data to the head driver; and

a storage section for storing information about a defective liquid discharging portion having discharging failure, the information being obtained by checking an actual pattern that indicates the discharging states of the droplets of the liquid discharging patterns,

wherein image formation on the recording medium is corrected by prohibiting the defective liquid discharging portion from discharging, and controlling discharging from a liquid discharging portion near the defective liquid discharging portion by changing the number of discharging shots from a liquid discharging portion disposed on one side of the defective liquid discharging portion, according to the information about the defective liquid discharging portion stored in the storage section.

12. A liquid discharging apparatus according to claim 11, wherein the storage section is provided inside the liquid discharging head, inside the image processing unit, or inside an external control unit.

13. A liquid discharging method according to claim 11, wherein the discharging failure means that no droplets are discharged from the defective liquid discharging portion.

14. A liquid discharging method according to claim 11, wherein the discharging failure means that the discharging direction from the defective liquid discharging direction deviates from an allowable range.

15. A liquid discharging method according to claim 11, wherein the discharging failure means that the amount of liquid in the droplets discharged from the defective liquid discharging portion is outside an allowable range.

16. (canceled)

17. A liquid discharging method according to any one of claims 13 to 15, wherein the discharging of the droplets from the liquid discharging portion near the defective liquid discharging portion is controlled by changing the number of discharging shots from liquid discharging portions disposed on both sides of the defective liquid discharging portion.

18. A liquid discharging method according to any one of claims 13 to 15, wherein the discharging of the droplets from the liquid discharging portion near the defective liquid discharging portion is controlled by alternately changing the discharging amount of liquid from liquid discharging portions disposed on both sides of the defective liquid discharging portion, or the number of discharging shots therefrom every time one line is formed.

19. A liquid discharging method according to any one of claims 13 to 15, wherein the discharging of the droplets from the liquid discharging portion near the defective liquid discharging portion is controlled by discharging the droplets according to new droplet discharging signals that are generated on the basis of original liquid discharging signals for the defective liquid discharging portion and liquid discharging portions on both sides thereof in order to reduce the influence of the discharging failure of the defective liquid discharging portion.

20. A liquid discharging method according to claim 19, wherein the new liquid discharging signals depend on the characteristics of the droplets, the type of a recording medium, or an image formation mode.

21. A liquid discharging method according to claim 19, wherein the new liquid discharging signals are listed in a table beforehand.

22-40. (canceled)

41. A liquid discharging method according to claim 9, wherein the new liquid discharging signals are listed in a table beforehand.

* * * * *