

(21) Application No: 1608295.0
(22) Date of Filing: 11.05.2016

(51) INT CL: A47L 9/04 (2006.01) A47L 9/02 (2006.01)

(56) Documents Cited: GB 2520549 A BE 000905711 A1

(71) Applicant(s):
Lupe Technology Limited
13 Castle Farm Road, Hanham, BRISTOL, BS15 3NJ,
United Kingdom

(58) Field of Search:
INT CL A47L
Other: WPI, EPODOC

(72) Inventor(s):
Lucas Horne
Pablo Montero-Cowell
Oliver Skittery

(74) Agent and/or Address for Service:
Haseltine Lake LLP
Redcliff Quay, 120 Redcliff Street, BRISTOL, BS1 6HU,
United Kingdom

(54) Title of the Invention: Cleaner head
Abstract Title: Cleaner head

(57) A cleaner head 10 for a vacuum cleaner comprises a suction inlet 20 defined in the lower face of a housing 11 and a suction passageway 20A through the housing 11, the suction passageway 20A being in fluid communication with the suction inlet 20. A rotatable sealing element 40 is located at a front of the housing 11. The rotatable sealing element 40 has a rotational axis 41 which is parallel to the lower face of the cleaner head 10 and the housing 11 at least partially surrounds the rotatable sealing element 40. An agitator 60 is positioned rearwards of the rotatable sealing element 40. The suction passageway 20A is located between the agitator 60 and the rotatable sealing element 40. A shielding member 50 may be located between the agitator 60 and the rotatable sealing element 40 with the suction passageway 20A being in fluid communication with a portion of the rotatable sealing element 40 above the shielding member 50. The rotatable sealing element 40 preferably includes an outer layer of resiliently deformable material such as closed cell foam. The rotatable sealing element 40 may include radially-extending blades.

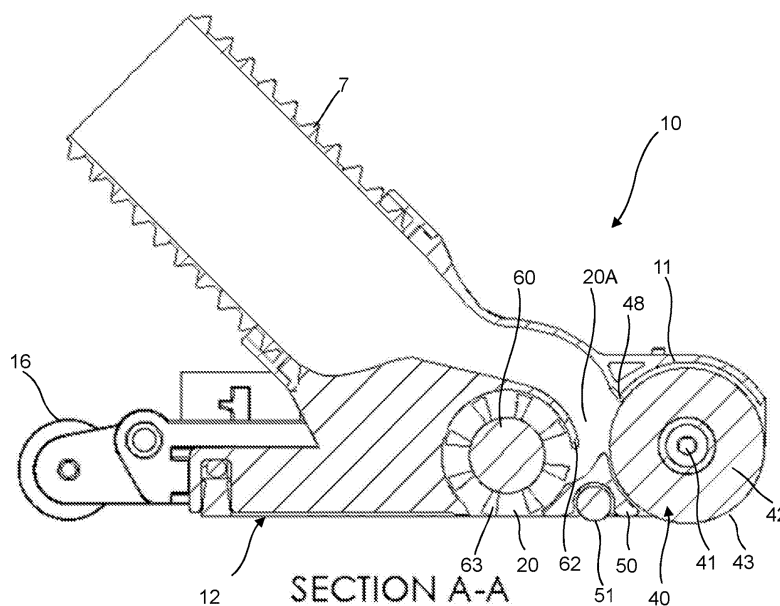

Fig. 3

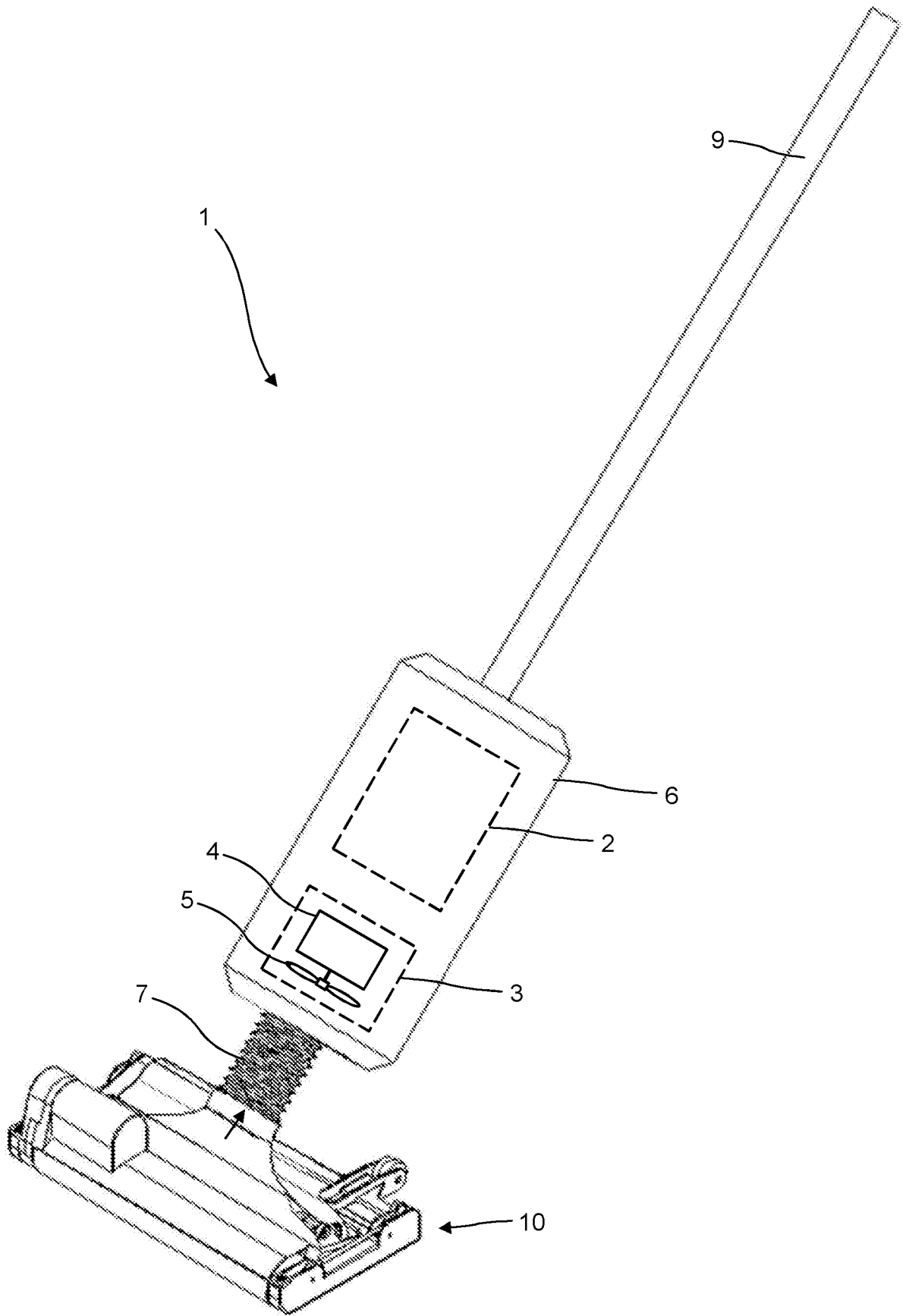

Fig. 1

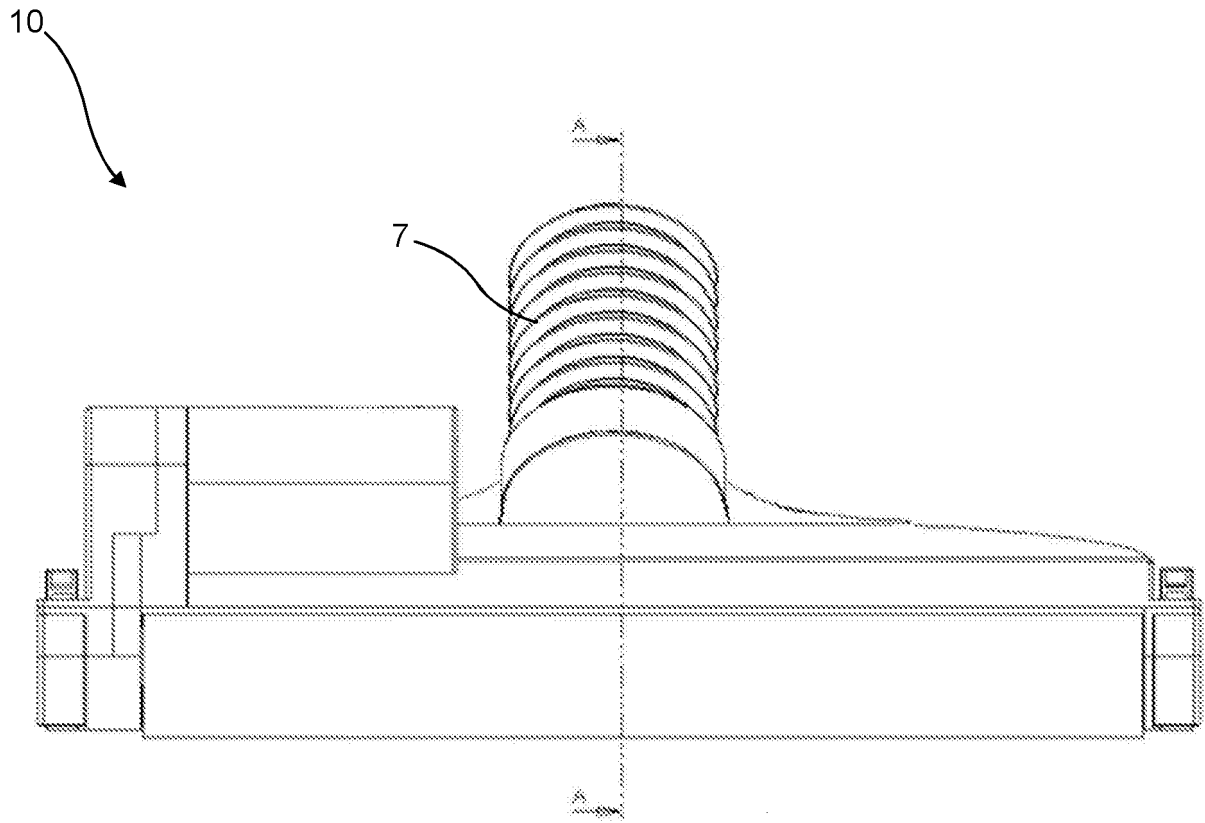

Fig. 2

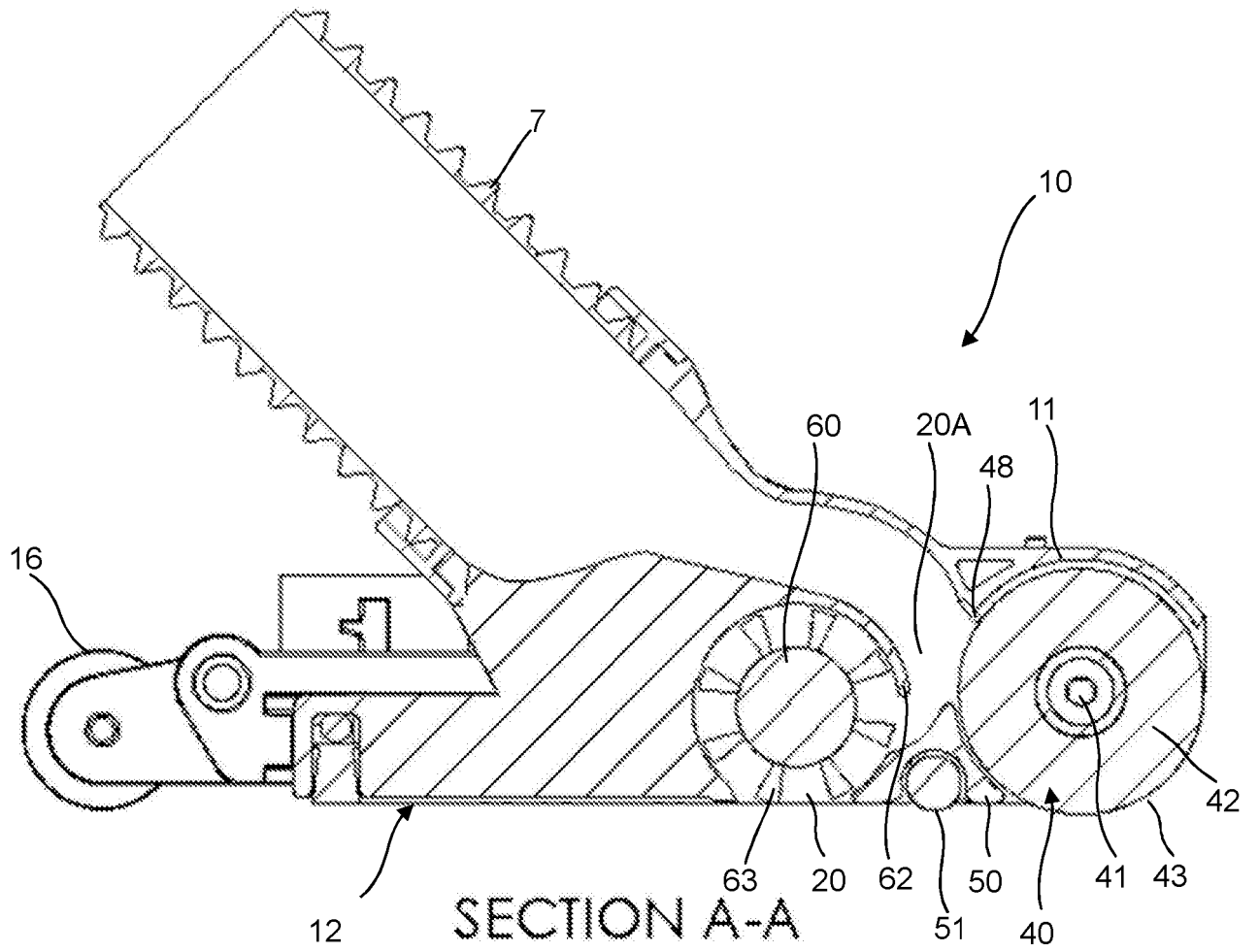

Fig. 3

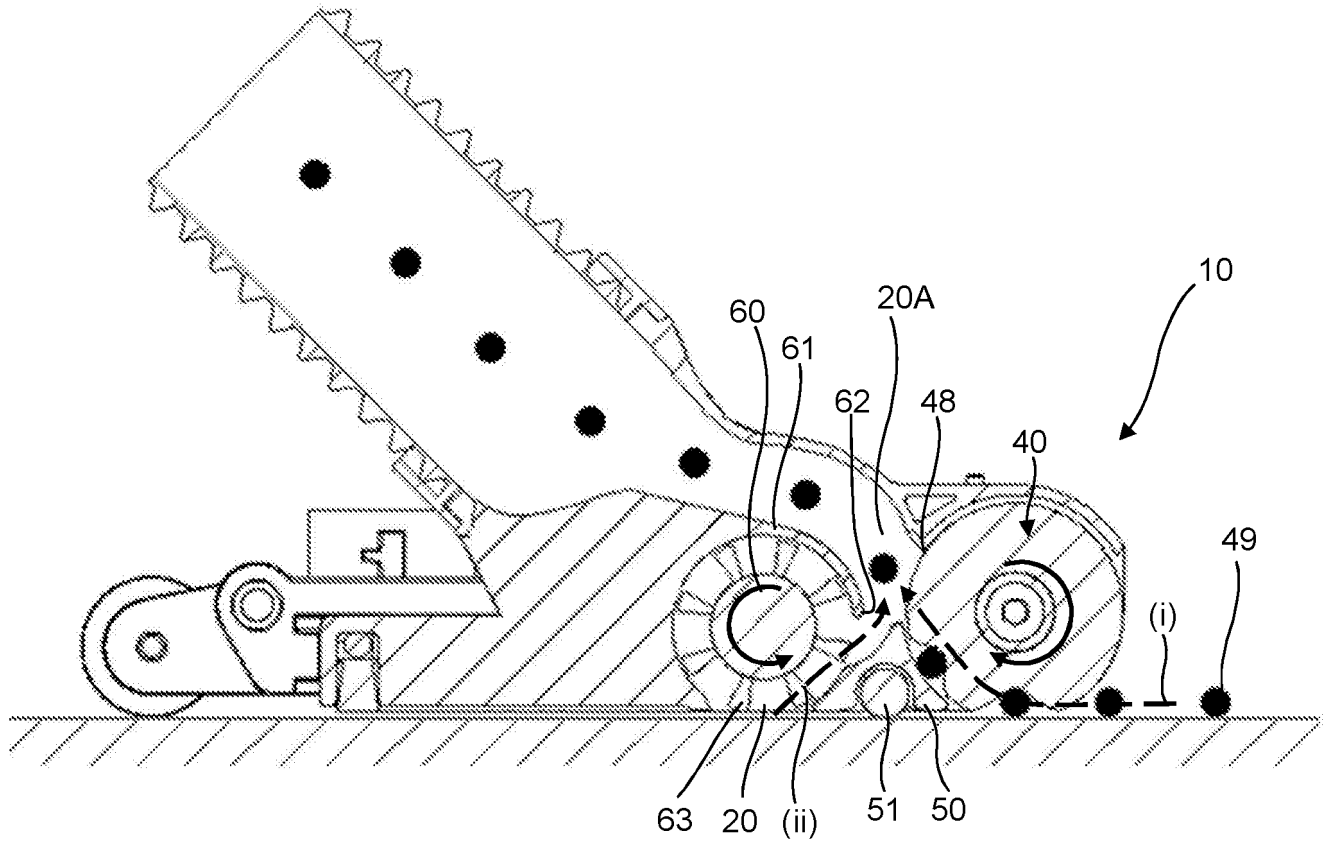
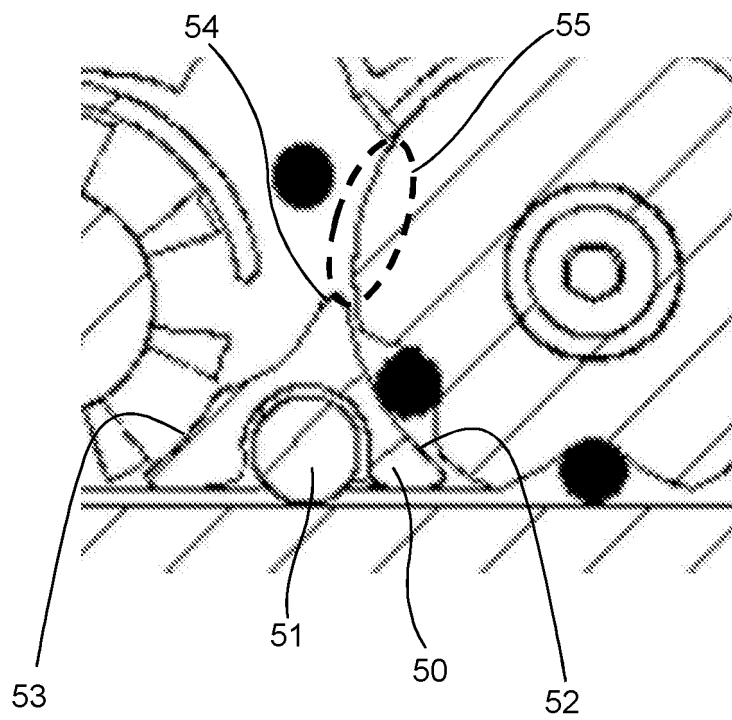

Fig. 4



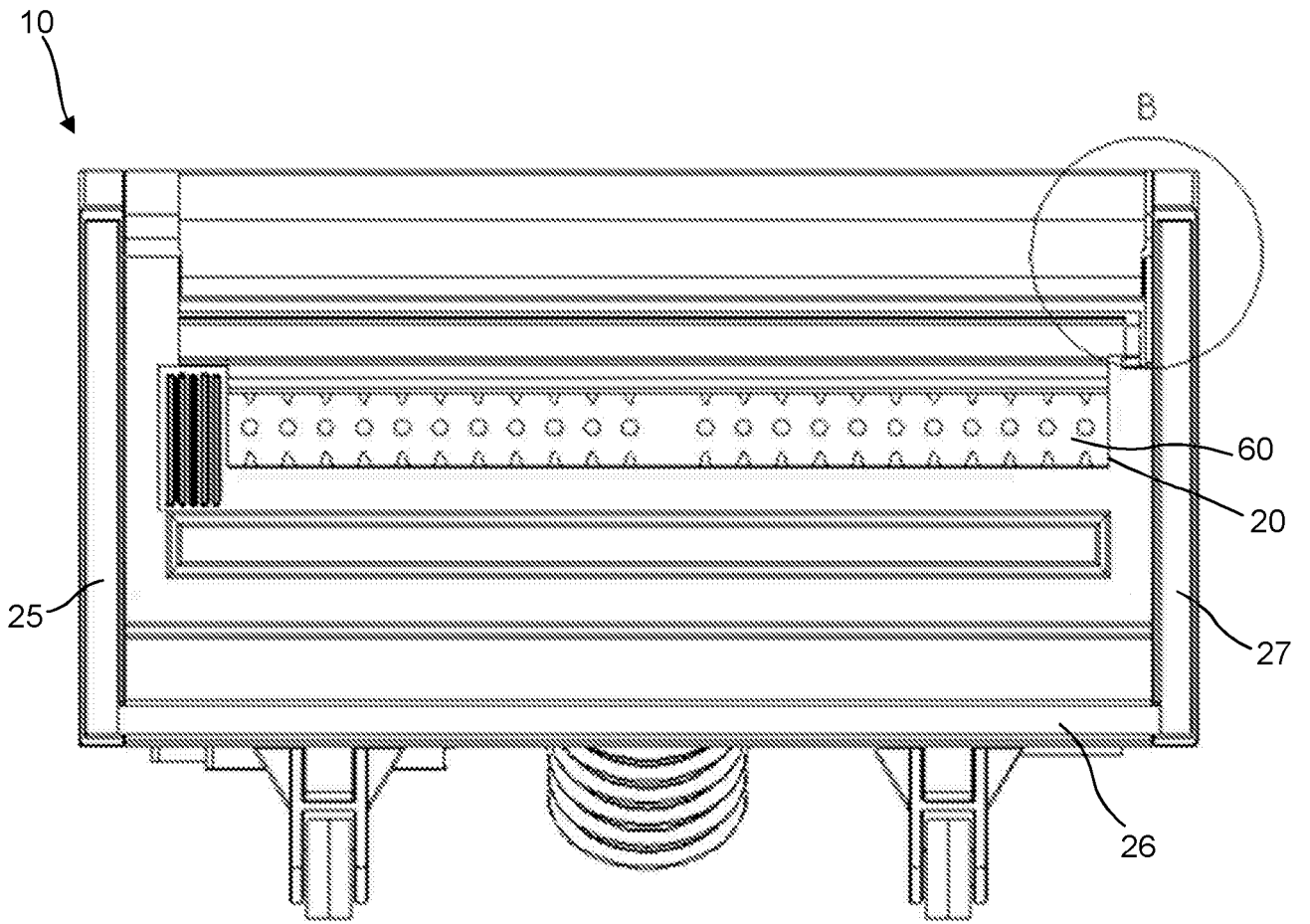

Fig. 5A

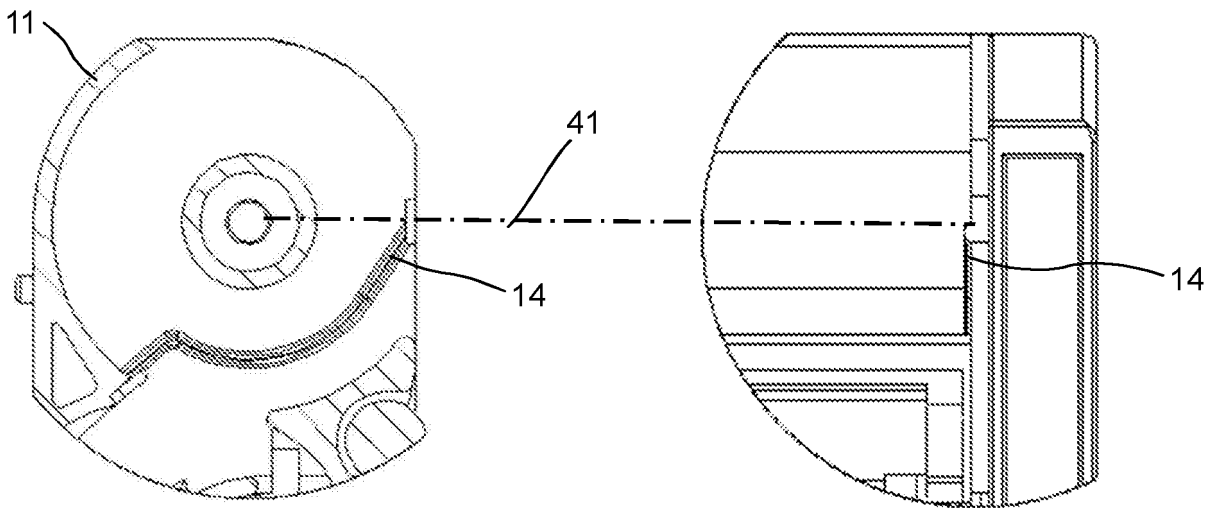

Fig. 5B

DETAIL B

Fig. 5C

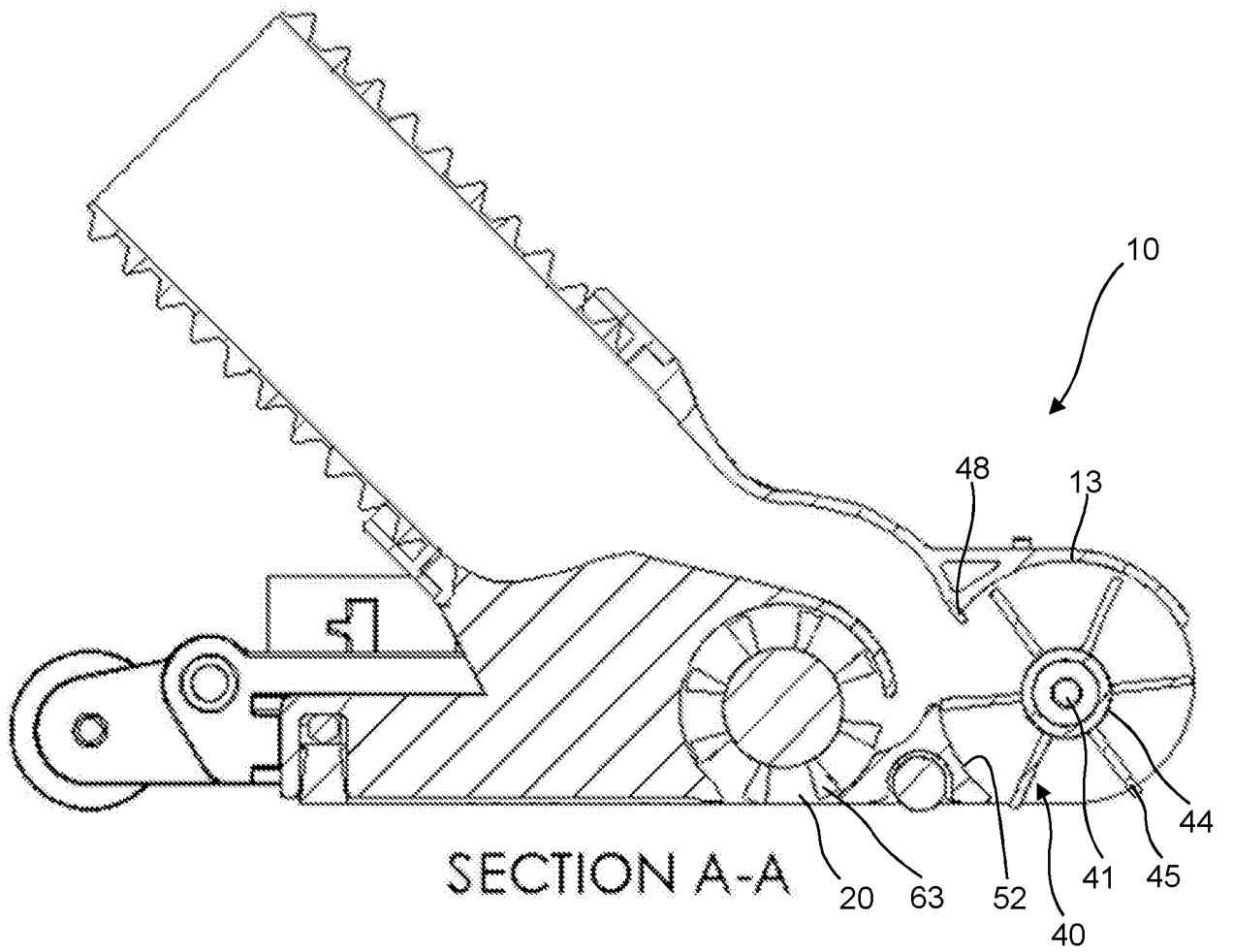

Fig. 6

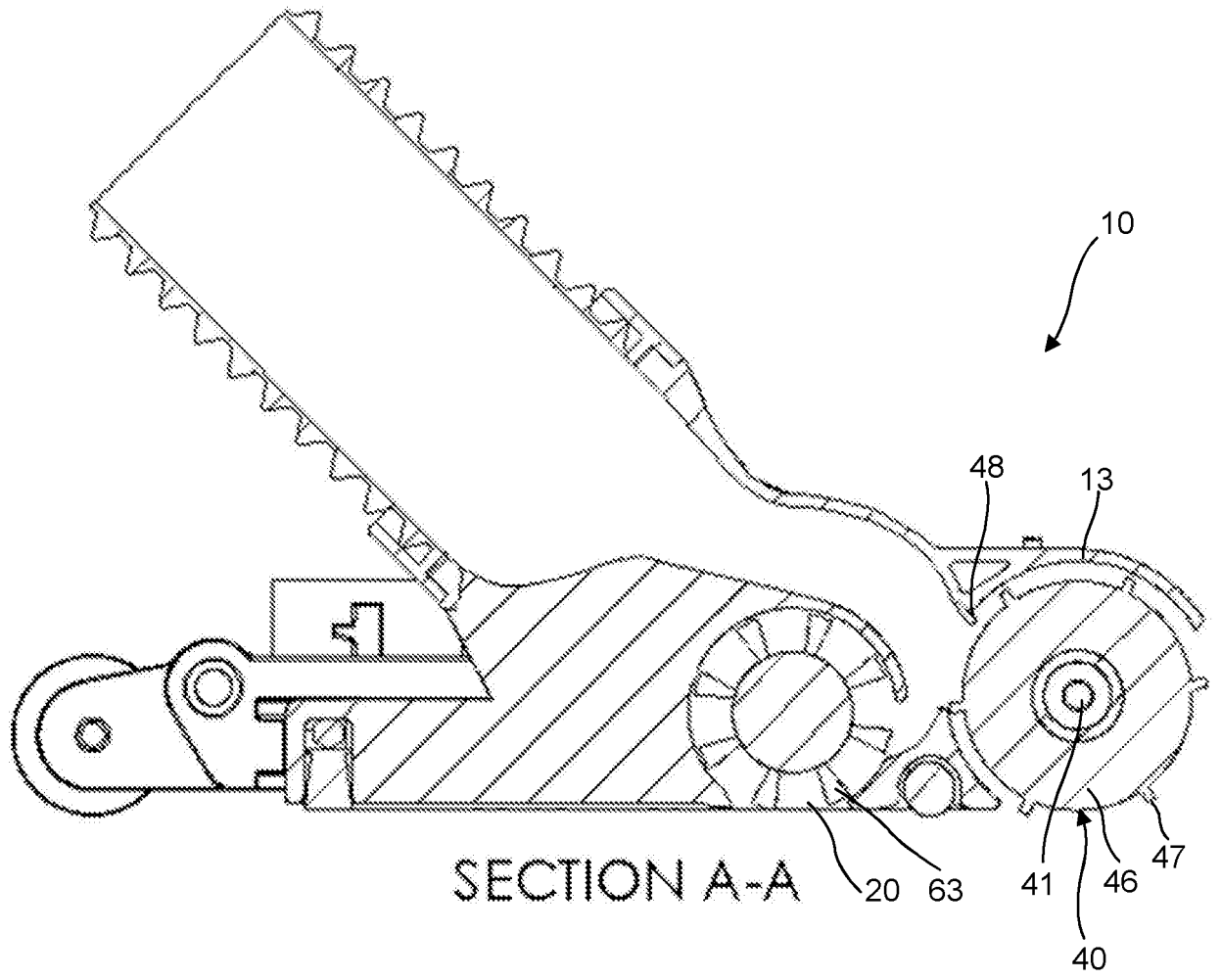

Fig. 7

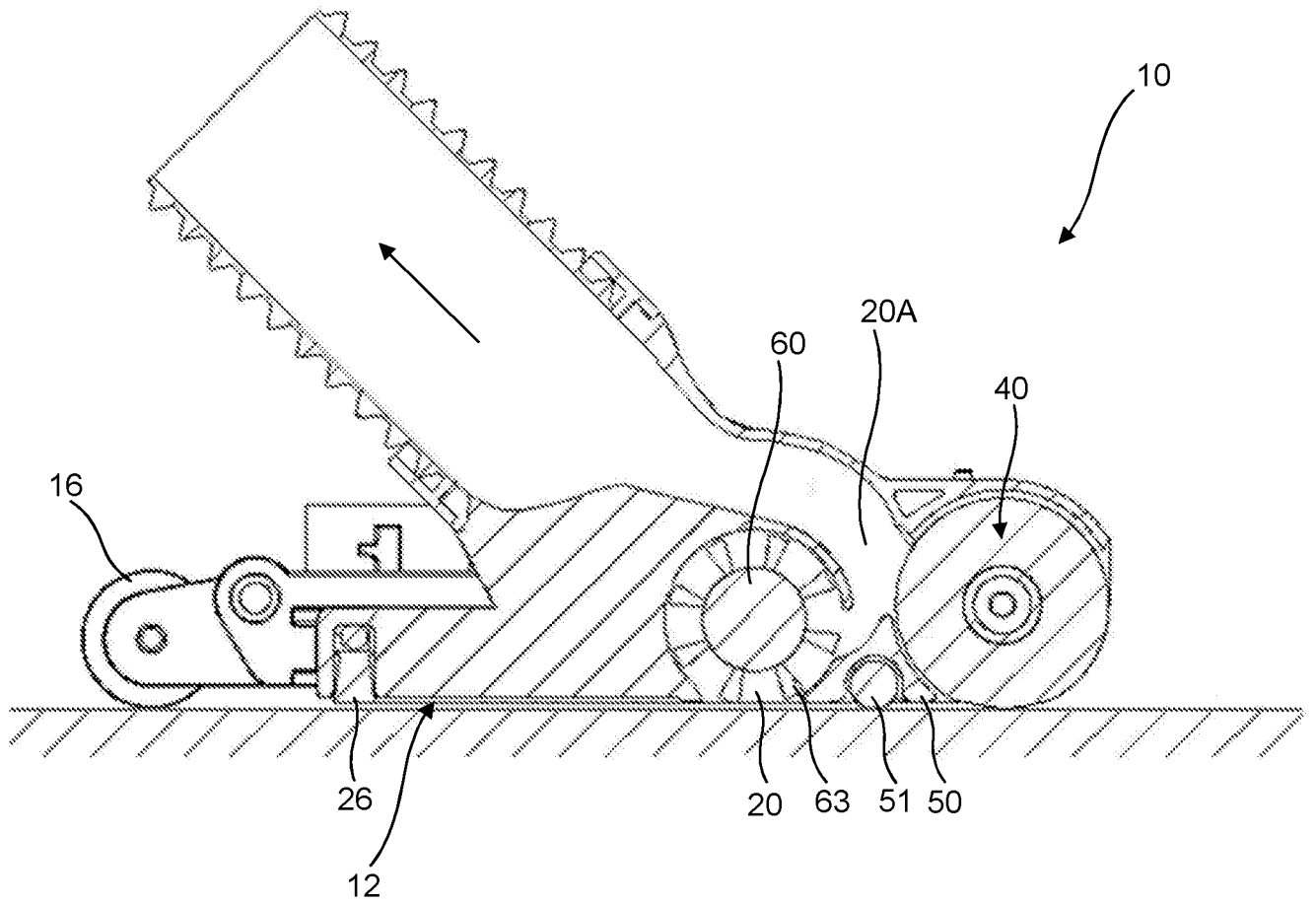

Fig. 8

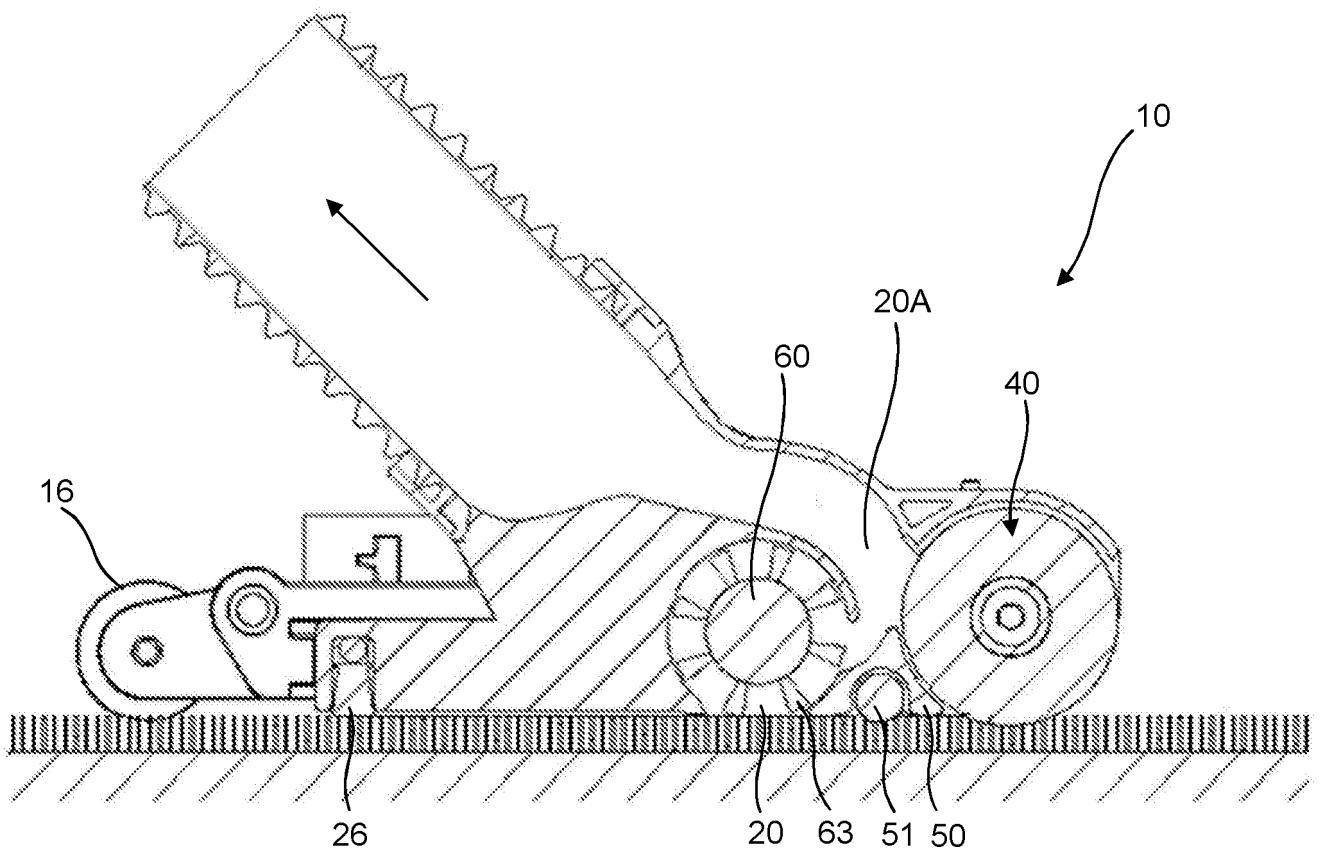
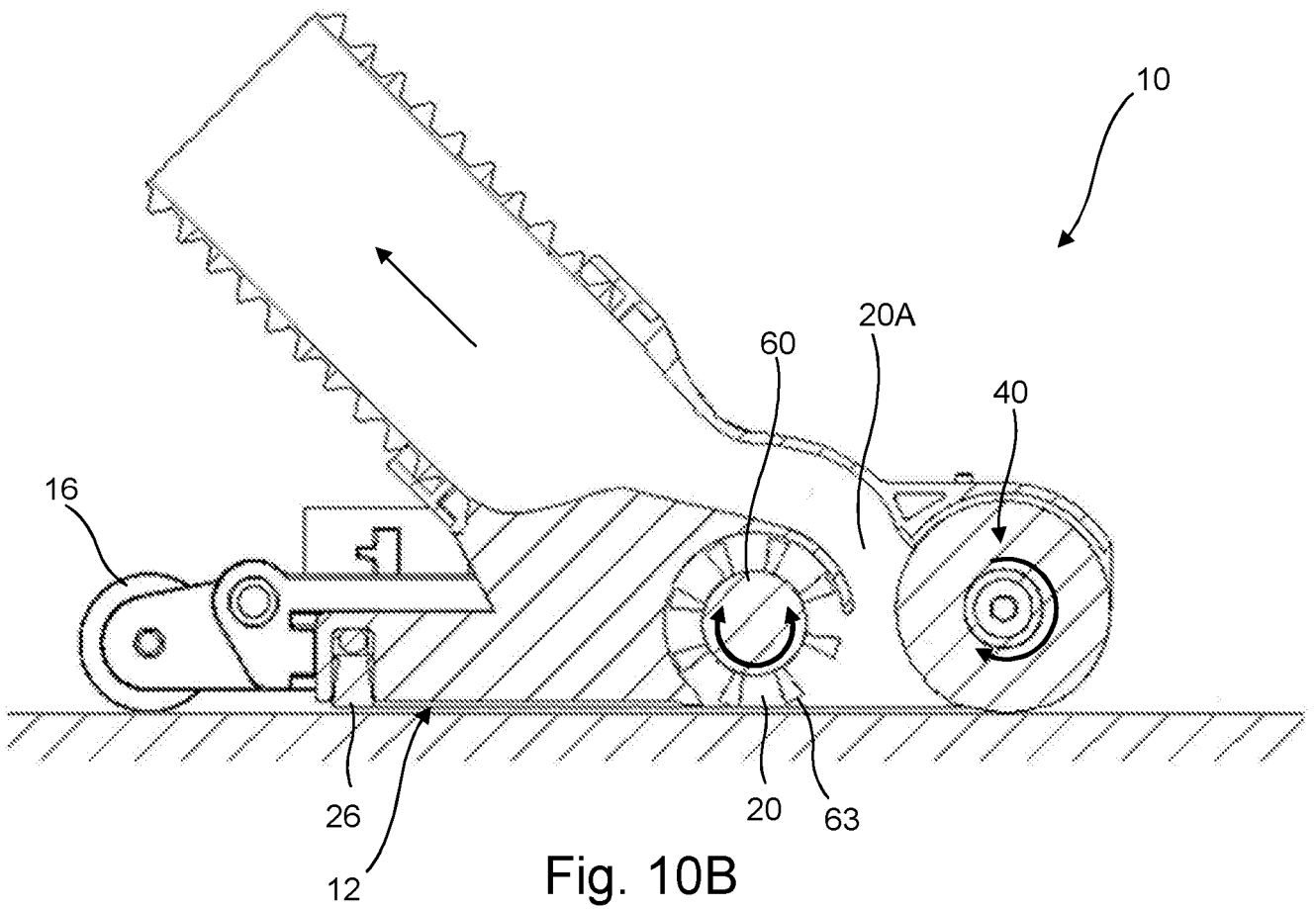
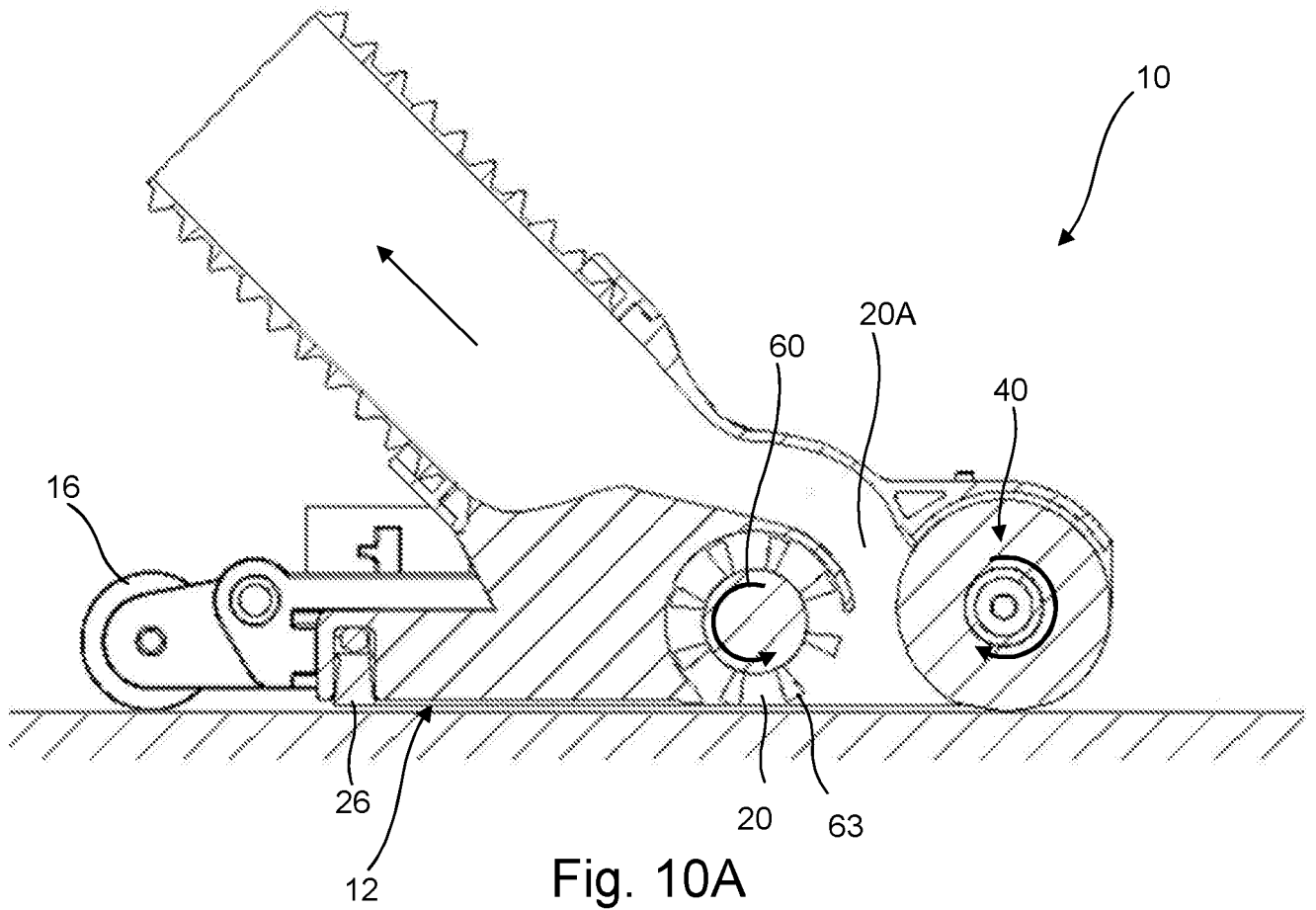

Fig. 9



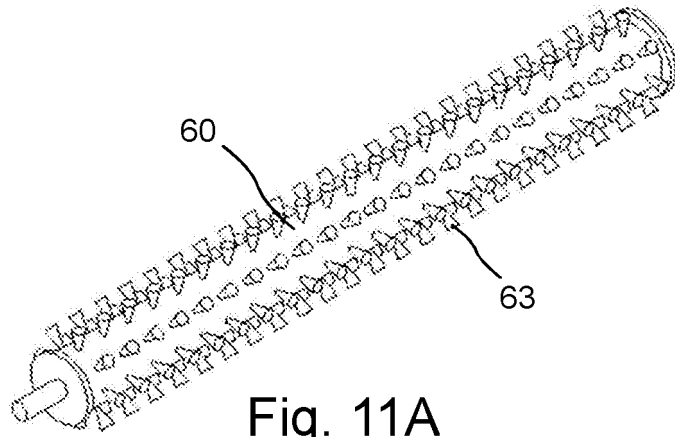

Fig. 11A

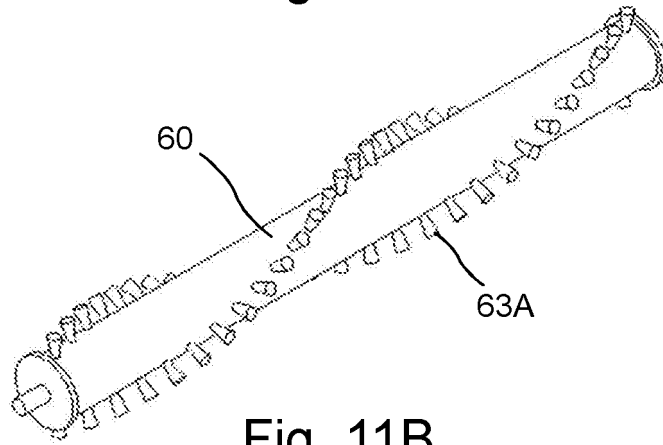

Fig. 11B

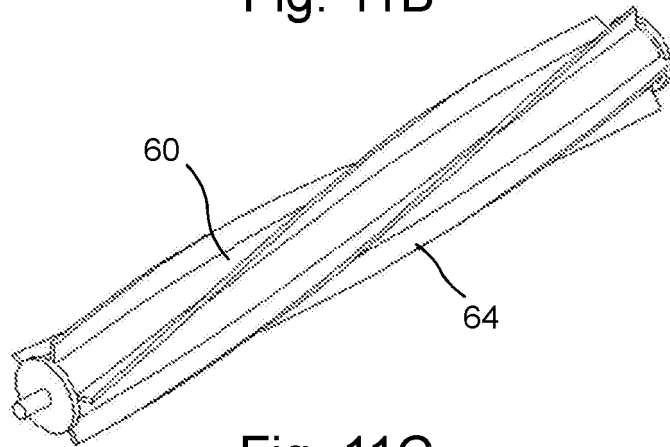

Fig. 11C

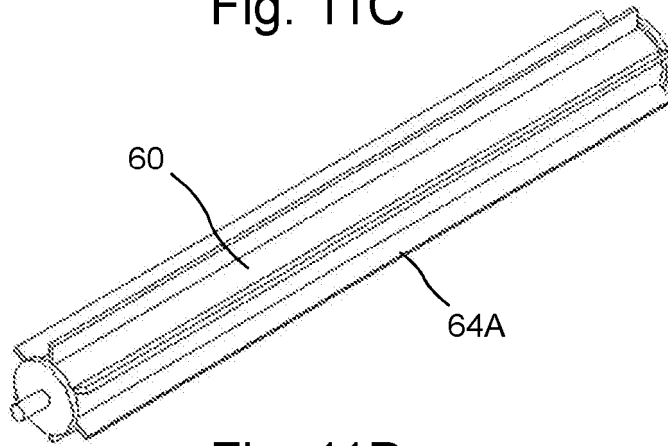

Fig. 11D

CLEANER HEAD

Background

Vacuum cleaners are a well-known form of appliance. Most vacuum cleaners today operate in a fundamentally similar way. The vacuum cleaner comprises a cleaner head (pick-up head) which is pushed across a surface, a separation system which can separate dirt/dust from an airflow, and a suction source (typically a motor and an impeller) to generate an airflow through the cleaner head and separation system. Dust/dirt is drawn from the surface to be cleaned and entrained in an airflow. The dirty airflow is pulled from the cleaner head to the separation system. Cleaned air is exhausted to the room. As the air is exhausted, a negative pressure is created at the pickup head.

There are many variations of separation systems: (filter bags, cyclonic separators, water tank) and sizes and designs of motor.

Different types of floor surface present different challenges. For carpeted floors, it is known to use a cleaner head with an agitator, such as a beater bar or a brush bar with stiff bristles for beating the carpet. The beater bar can be driven by an electric motor at high speeds, commonly between 2,000-8,000RPM to beat the carpet. The beater bar employs radially protruding stiff bristles, such as those disclosed in US 1,886,129, to part the carpet pile as the agitator is rotated. This high speed rotation greatly improves the amount of dust that can be freed from within the carpet pile, to be entrained in an airflow and then collected in the vacuum bag or collection chamber. This has the advantage that the stiff bristles agitate the carpet to release debris from within the pile and a higher dust pick up efficiency can be attained on carpet compared to a cleaner head without an agitator.

On hard floor surfaces, an agitator is generally not used as the high speed rotation of the agitator and contact with the floor surface can mark and damage hard floors. In some types of cleaner, such as an upright machine provided with an agitator, the agitator can be turned off when the cleaner is used to clean hard floors. On other cleaners, a cleaner head without an agitator may be provided. This is known as a passive head in the art. A passive cleaner head may be provided with linear brush seals. An example of a passive head with seals is described in GB 2,374,523 A. This improves sealing between the cleaner head and the floor surface. A disadvantage of this type of cleaner head is that the brush seals prevent large debris from entering the cleaner head. Debris is pushed along in front of the cleaner head. Cleaner heads of this type have to be lifted off the surface to pick up large debris, losing the effect of the suction when trying to draw dust out from crevices and cracks underneath the head.

WO 2015/015167 A2 describes a cleaner head for a vacuum cleaner with an agitator in the form of a brush bar at a front of the cleaner head. The agitator comprises radially

extending carbon fibre bristles and a sealing material disposed between the bristles. This cleaner head can seal against the surface to be cleaned and enable large debris to be brought into the head. This cleaner head is primarily intended for use on hard floors.

5 Some types of vacuum cleaner, such as some cylinder (canister) machines and some hand-held machines, are provided with multiple cleaner heads which are suited to cleaning different types of floor. A user can select the cleaner head best suited to the type of floor to be cleaned. While this can offer good cleaning performance, it is more costly, requires increased storage space for the multiple cleaner heads, and requires additional time and nuisance of changing cleaner heads.

10 Vacuum cleaners which only have a single cleaner head attempt to provide an acceptable quality of pick-up across a range of floor types but often only achieve a good quality of pick-up on one type of surface (carpeted floors or hard floors).

In any of the examples, the fluid may be air, water, cleaning fluid, or some other fluid. Typically, the fluid will be air.

15 Embodiments of the present invention seek to improve the performance of a vacuum cleaner head intended for on multiple floor types.

Summary

20 This Summary is provided to introduce a selection of concepts in a simplified form that are further described below in the Detailed Description. This Summary is not intended to identify key features or essential features of the claimed subject matter, nor is it intended to be used as an aid in determining the scope of the claimed subject matter.

An aspect provides a cleaner head for a vacuum cleaner comprising:

25 a housing configured to be movable across a floor surface, the housing having a lower face;

a suction inlet defined in the lower face of the housing;

a suction passageway through the housing, the suction passageway in fluid communication with the suction inlet;

30 a rotatable sealing element located at a front of the housing, the rotatable sealing element having a rotational axis which is parallel to the lower face of the cleaner head, the housing at least partially surrounding the rotatable sealing element;

an agitator positioned rearwards of the rotatable sealing element;

wherein the suction passageway is located between the agitator and rotatable sealing element.

At least one example of the present disclosure has an advantage of providing good pick up performance on large debris, in particular on hard floors while also allowing a good degree of sealing to a range of floor surfaces. The rotatable sealing element allows debris to enter the cleaner head while a good degree of sealing is maintained, enabling dust to be drawn out of cracks and crevices without the need to lift the head up to permit entry of large debris.

At least one example of the present disclosure has an advantage of allowing debris to reach the suction passageway without having to pass under the agitator. This can protect hard floors from potential damage. In some prior art cleaner heads, large debris can become trapped under the agitator and scrape along a floor surface.

The agitator may be turned off for some floor types, such as hard floors. This can also protect hard floors from potential damage.

At least one example of the present disclosure has an advantage of providing good pick up performance on carpet as the secondary agitator acts as a beater bar that can rotate at high rpm to part carpet pile with stiff protruding members.

The cleaner head may comprise a shielding member located between the agitator and the rotatable sealing element. The suction passageway is in fluid communication with a portion of the rotatable sealing element above the shielding member.

The shielding member can improve pick-up performance by reducing disturbance of debris brought into the cleaner head.

The shielding member may guide debris to a position where it can be released into the suction passageway with a higher chance of being carried out of the cleaner head.

The shielding member may extend to the lower face, the shielding member configured to shield a rearward side of the rotatable sealing element, proximate the lower face of the cleaner head.

The cleaner head may comprise a roller mounted rotatably with respect to the shielding member, the roller configured to provide a seal between the shielding member and a floor surface.

The shielding member may have a surface on the rearward side configured to guide fluid flow away from rearward side of the rotatable sealing element, proximate the lower face of the cleaner head.

The shielding member may have a surface on the forward side which is coaxial with the rotational axis of the rotatable sealing element.

There may be a clearance between the surface on the forward side of the shielding member and an outer surface of the rotatable sealing element. The clearance may be less than 3mm, and optionally less than 1mm.

5 The cleaner head may comprise an agitator housing which partially encloses the agitator, the agitator housing having an opening on a front side, the opening defined by a lip of the agitator housing, wherein the shielding member extends to a height which is substantially the same as the lip of the agitator housing. This can help to improve transfer of debris to flow through the suction passageway.

10 The rotatable sealing element may comprise a continuous outer layer of deformable material. The deformable material may be resiliently deformable material, such as closed cell foam.

The rotatable sealing element may comprise a plurality of flexible radially-extending blades or splines in combination with deformable material between the blades/splines. Alternatively, the rotatable sealing element may comprise a plurality of flexible, radially-extending blades without deformable material between the blades/splines.

15

The cleaner head may comprise a drive, such as a motor, which is configured to rotate the rotatable sealing element independently of movement of the cleaner head across a surface.

20 The rotatable sealing element may be rotated at a speed which is less than a rotational speed of the agitator. For example, rotatable sealing element may be rotated at a speed in the range 30 - 500 RPM and the agitator may be rotated at a speed up to 20000 RPM.

The cleaner head may comprise a seal between a side face of the rotatable sealing element and the housing.

25 The cleaner head may comprise a brush seal located at a perimeter of the cleaner head on at least one of: side edges of the cleaner head; rear edge of the cleaner head. The brush seal may be adjustable in height.

The cleaner head may comprise a sealing element to provide a seal between the housing and the rotatable sealing element.

30 The sealing element may be located on a rearward side of the rotatable sealing element, within the housing.

The sealing element may be configured to scrape debris from an outer surface of the rotatable sealing element.

The cleaner head may comprise a scraper which is configured to scrape debris from an outer surface of the rotatable sealing element.

The agitator may comprise a plurality of radially-extending brush filaments. The agitator may be a beater bar.

5 The agitator may comprise a plurality of radially-extending blades.

The cleaner head may comprise a drive configured to rotate the agitator independently of movement of the cleaner head across a surface. The agitator may be rotated at a speed of up to 20000 RPM.

The agitator may be oscillated about a longitudinal axis of the agitator.

10 The cleaner head may be used with any type of vacuum cleaner, such as: an upright cleaner; a cylinder (canister) cleaner; a stick-vac; a hand-held cleaner; a robotic cleaner.

Another aspect provides a vacuum cleaner comprising a cleaner head as described or claimed.

15 The preferred features may be combined as appropriate, as would be apparent to a skilled person, and may be combined with any of the aspects of the invention.

Brief Description of the Drawings

Embodiments of the invention will be described, by way of example, with reference to the following drawings, in which:

20 Figure 1 shows a vacuum cleaner with a cleaner head;

Figure 2 shows a front view of the cleaner head of Figure 1;

Figure 3 shows a cross section of the cleaner head of Figure 2;

Figure 4 shows another cross section of the cleaner head, illustrating pick up of debris;

25 Figure 5A shows a view of the underside of the cleaner head;

Figures 5B and 5C show detail of the housing in the region where the rotatable element is located;

Figure 6 shows a cross section of the cleaner head, illustrating an alternative form of the rotatable element;

30 Figure 7 shows a cross section of the cleaner head, illustrating an alternative form of the rotatable element;

Figure 8 shows a cross section of the cleaner head, illustrating operation on a non-porous floor surface;

Figure 9 shows a cross section of the cleaner head, illustrating operation on a porous floor surface;

5 Figures 10A and 10B shows a cross section of an alternative form of the cleaner head without a shielding member;

Figure 11A shows a view of the agitator;

Figures 11B, 11C and 11D show views of alternative forms of an agitator;

10 Common reference numerals are used throughout the figures to indicate similar features.

Detailed Description

Embodiments of the present invention are described below by way of example only. These examples represent the best ways of putting the invention into practice that are currently known to the Applicant, although they are not the only ways in which this could be achieved. The description sets forth the functions of the example and the sequence of steps for constructing and operating the example. However, the same or equivalent functions and sequences may be accomplished by different examples.

20 Figure 1 shows a vacuum cleaner 1 comprising a cleaner head 10, a separation system 2, a suction source 3 and duct 7 which connects to the cleaner head 10. The separation system 2 and the suction source 3 may be housed within a housing 6. The vacuum cleaner 1 comprises a handle 9 for pushing the cleaner head across a floor surface.

25 Duct 7 is fluidly connected to the cleaner head 10 and to the separation system 2. Duct 7 is configured to carry dirt-laden fluid (e.g. air) from the cleaner head 10 to the separation system 2. Duct 7 may be a flexible hose, rigid pipe or any other type of fluid-carrying duct.

30 The separation system 2 is configured to separate dirt/dust/debris from the fluid received via duct 7. The separation system 2 can be of any kind, such as a filter bag, a cyclonic separation system (with one or more cyclonic separation stages), a water filter, an electrostatic filter. The separation system may comprise a porous filter, or may not comprise a porous filter. The suction source 3 may comprise an electrical motor 4 and an impeller 5. The suction source 3 may be located downstream of the separation system 2, or the suction source 3 may be located upstream of the separation system 2. Locating the suction source 3 downstream of the separation system 2 is advantageous, as the suction source operates upon cleaned fluid (air) rather than dirt-laden fluid. The "fluid" that is carried along duct 7 may be air. Alternatively, the fluid may be water, a cleaning fluid, or some other fluid.

Figure 2 shows the cleaner head 10 with duct 7. Although the duct shown is central it could be offset or positioned anywhere along the width of the cleaner head 10.

Figure 3 shows a cross-section A-A through the cleaner head of Figure 2. The cleaner head 10 comprises a housing 11. The housing 11 has a lower face 12. This is often called a sole plate. The lower face is the part of the cleaner head 10 which faces a floor surface. The lower face 12 comprises a frame of the housing 11 with apertures defined in it to allow air flow to/from the floor surface, and to allow components such as the rotatable element 40 and an agitator 60 to make contact with the floor surface. The agitator in this embodiment is constructed of radially protruding stiff nylon bristles 63 which are design to impart a parting force to the carpet pile. The lower face 12 is configured to move across a surface to be cleaned. The housing may comprise one or more wheels 16, rollers or other features to assist movement of the cleaner head 10 across a floor surface.

The cleaner head 10 comprises a suction inlet 20 defined in the lower face (sole plate) 12 of the housing. There is a suction passageway 20A through the housing 11. The suction passageway 20A is in fluid communication with the suction inlet 20 and with the duct 7. The cleaner head 10 comprises a rotatable sealing element 40 located at a front of the housing 11. The rotatable sealing element 40 is configured for rotation about a rotational axis 41. For example, the rotatable sealing element 40 may be supported by the housing 12 at each end. The rotational axis 41 is parallel to the lower face 12 of the cleaner head. The housing 11 at least partially surrounds the rotatable sealing element 40. In this example, the housing 11 surrounds an upper portion of the rotatable sealing element 40, above the rotational axis 41. A lower portion of the rotatable sealing element 40 is configured to make contact with the surface to be cleaned. The front of the rotatable sealing element 40 is exposed, allowing the rotatable sealing element 40 to serve as a bumper when the cleaner head 10 pushes against an upright object, such as a skirting board or furniture.

In the example of Figure 3 the rotatable sealing element 40 is in the form of a roller with a continuous outer layer of resiliently deformable material. The resiliently deformable material may be a closed-cell foam or other elastomeric material, such as polyurethane. A material such as closed cell foam is advantageous as the material is non-porous, and therefore blocks fluid flow. However, the closed-cell material is resiliently deformable, i.e. it can be deformed from an initial state to accommodate debris and then return to its initial state after the debris has been removed. The rotatable sealing element 40 can form a seal between the cleaner head 10 and a surface to be cleaned. On non-porous surfaces, such as hard floors, the rotatable sealing element 40 can form a seal, or partial seal, to limit air being drawn into the head from the front of the head and encourage air to be drawn from underneath the head. The rotatable sealing element 40 can allow debris to enter the cleaner

head 10, rather than pushing the debris in front of the cleaner head, while also maintaining a seal.

Figure 3 shows the cleaner head comprising an agitator, such as a beater bar (brush bar) 60. A drive, such as an electric motor, is provided to drive the agitator 60. The agitator 60 may rotate at speeds of up to 20000 RPM for effective agitation of carpets and rugs. The drive for the agitator 60 may be turned on and off, such as by a switch on the vacuum cleaner. For example, a user may choose to switch the agitator off when cleaning hard floors, where there is not a need to “beat” the carpet. A single drive may be provided for both the agitator 60 and the rotatable element 40, with transmission to distribute motor power to the agitator 60 and the rotatable element 40. The rotatable sealing element is preferably rotated at speeds in the range of 30 - 500 RPM for example but could equally operate in the range of 500 – 2000 RPM. High speed rotation of the rotatable sealing element 40 is not required to seal and adequately bring in debris to suction passageway 20A in comparison to the high speed rotation required for the agitator to beat the carpet pile. This has the advantage of reducing energy consumption, eliminating the risk of damage to hard floors and enable each of the rotatable sealing element and agitator to perform its function accordingly, to “seal” and to “agitate”.

The cleaner head comprises a shield 50. In Figure 3 the shielding member is a shielding member 50. The shielding member 50 is located between the agitator 60 and the rotatable sealing element 40. The shielding member 50 extends substantially to the level of the lower face 12 of the housing. The shielding member 50 extends across the width of the cleaner head. The shielding member 50 is configured to shield a rearward side of the rotatable sealing element 40, proximate the lower face 12 of the cleaner head. The shielding member 50 shields the rearward lower portion of the rotatable sealing element 40 from debris and air from the agitator 60. The shielding member 50 also has a function of guiding debris which enters the cleaner head via two possible routes: (i) a route via the rotatable element 40; and (ii) a route via agitation by from the agitator 60 and suction of suction inlet 20. The shielding member prevents negative interaction between the two debris paths in the region proximate the floor surface. From Figure 3, it can be seen that the suction passageway 20A is located between the agitator 60 and the rotatable sealing element 40. The suction passageway 20A is in fluid communication with a portion of the rotatable sealing element 40 above the shielding member 50.

A feature of the cleaner head 10 shown in Figure 3 is that both large debris (e.g. debris lying on, or close to, the surface to be cleaned) and small debris/dust can enter the cleaner head 10. This eliminates the need to lift the cleaner head 10 off the surface whilst passing over debris, thus preventing a leakage of air into the head.

Figure 4 shows operation of the rotatable sealing element 40 to pick up debris 49. As the cleaner head 10 is moved across a surface to be cleaned, the rotatable sealing element 40 deforms to allow the debris 49 to pass under the rotatable sealing element 40. A seal is maintained between the rotatable sealing element 40 and the surface. The rotatable sealing element 40 deforms as the cleaner head 10 passes over uneven surfaces, to maintain a seal. Debris 49 is guided into the suction passageway 20A via two possible routes: (i) through the front of the cleaner head 10 via the rotatable sealing element 40; and (ii) from the action of the optional beater bar 60 on the surface. The rotatable sealing element 40 rotates in a clockwise direction, as shown by the arrow in Figure 4. Debris 49 which enters the cleaner head via the rotatable sealing element 40 is 'trapped' between the rotatable sealing element 40 and a forward side 52 of the shielding member 50. As the rotatable sealing element 40 continues to rotate, the debris is released when the debris clears the top 54 of the shielding member 50. The deformable properties of the rotatable sealing element 40 have the effect of "pushing" debris radially outwards (towards the left in Figure 4) when the debris clears the top 54 of the shielding member 50. This pushes the debris into the airflow path towards the suction passageway 20A.

In the example shown in Figure 4 a surface on the forward side 52 of the shielding member 50 is coaxial with the rotational axis 41 of the rotatable sealing element 40. The forward side 52 of the shielding member 50 can have a clearance with respect to the outer surface of the rotatable element 40. An example range for the clearance is 0.5-3mm. Providing a clearance can allow debris to transfer to suction passageway 20A without falling down, or jamming the rotation of, the rotatable sealing element 40.

The agitator is located within an agitator housing 61. The agitator housing 61 partially encloses the agitator 60. The agitator housing 61 surrounds the agitator on the rear face, top and part of the front face of the agitator. The agitator housing 61 has an opening on the front side. The opening in the agitator housing 61 is defined by an edge or lip 62. The suction passageway 20A extends from the suction inlet 20, through the lower part of the agitator 60 and through the opening in the agitator housing 61 beneath lip 62. In some examples, the highest point 54 of the shield can be level with, or at a similar level to, the feature 62. This can help to ensure large debris is transferred to the suction passageway 20A. If the highest point 54 of the shield 50 is lower than feature 62 there is a higher possibility that large/heavy debris which is transferred via the rotatable element 40 may drop downwards towards the agitator 60 when it is released from the rotatable sealing element 40. The highest point 54 of the shield 50 can be higher than feature 62, but debris has a longer path to travel before it is released from the rotatable sealing element 40 and transferred towards the suction passageway 20A.

The beater bar 60 rotates in a direction towards the suction passageway. This is against the direction of forward motion of the cleaner head (i.e. the beater bar 60 rotates anti-clockwise in Figure 4). Stated another way, the beater bar rotates such that stiff protruding members 63 are driven down from the back of the beater bar, and rotated towards the front of the cleaner head. This direction of rotation parts the carpet pile and guides debris forwards towards the suction passageway 20A. This direction of rotation is opposite to conventional cleaner heads, where the beater bar typically rotates with the direction of forward motion of the cleaner head.

A seal 48 extends parallel to the rotational axis 41 of the rotatable sealing element 40. The seal 48 extends along the length of the rotatable sealing element 40. The seal 48 forms a seal between the housing 11 and the rotatable sealing element 40, thereby preventing leakage of air between the housing and the top of the rotatable sealing element 40. The seal 48 also acts as a scraper. The seal 48 is in contact with the outer surface of the rotatable sealing element 40 and can scrape debris from the outer surface of the rotatable sealing element 40. In another example, a scraper may be provided separately from the seal 48. A portion 55 of the rotatable sealing element 40 between the top 54 of the shield and below the seal 48 is in fluid communication with the suction passageway 20A.

In Figures 3 and 4 the shielding member 50 comprises an auxiliary roller 51. The auxiliary roller 51 has the same length as the shielding member 50 such that the auxiliary roller extends across the width of the cleaner head 10.

The purpose of the auxiliary roller 51 is to provide an additional seal. Roller 51 provides a second line of sealing. In the absence of the auxiliary roller 51, when the rotatable sealing element 40 deforms to accommodate larger debris (e.g. greater than 1mm mean diameter), the seal formed between the rotatable sealing element 40 and the surface to be cleaned may be compromised enough to allow a (small) detrimental leak path underneath the shield 50 into the cleaner head 10. The addition of the auxiliary roller 51 helps to seal the cleaner head, even when the rotatable sealing element 40 deforms to allow debris to pass. Small debris (e.g. 1mm or less mean diameter) can pass under the auxiliary roller 51 of the shield 50. The small debris will be acted upon by the beater bar 60 or suction in the vicinity of the beater bar 60. In a similar fashion to the rotatable sealing element 40, the auxiliary roller 51 can deform to accommodate this small debris and bring it into the cleaner head 10.

The shielding member 50 is shown in the drawings as a single element with a forward side 52, a rearward side 53 and a base with a roller 51. In other examples, the shielding member 50 can be implemented as a single wall, or as a pair of separate walls 52, 53 which extend laterally across the housing 11. Advantageously, wall 52 should be continuous with wall 53 in region 54 so that debris cannot fall into a gap between the walls 52, 53. A surface on a forward side 52 of the shielding member 50 may be vertical, but a surface which is

coaxial with the rotational axis 41 of the rotatable sealing element 40 has advantages of improved sealing and of guiding debris to a higher position within the cleaner head.

The rotatable sealing element 40 can be driven in one direction (forwards, clockwise in Figure 4) by an electric motor, or it can rotate in either direction by friction between the
5 rotatable element 40 and the surface to be cleaned.

Figure 5A shows a view of the underside of the cleaner head 10. Figures 5B and 5C show detail of the housing in the region where the rotatable sealing element 40 is located. Figure 5B shows part of the housing 11 which fits alongside one end of the rotatable sealing element 40. In Figures 5A-5C the rotatable sealing element 40 is missing, to more clearly
10 show detail of sealing in this area. A seal 14 fits between a side face of the rotatable sealing element 40 and the housing 11. The seal 14 reduces, or prevents, leakage of air around the side of the rotatable sealing element 40.

Figure 5A shows brush seals 25, 26, 27 that extend from the cleaner head 10 onto the surface to be cleaned, in order to allow the cleaner head to seal better to the surface to be
15 cleaned such as a hard floor and enable more dust to be sucked out of cracks and crevices. The relative vertical position of the brush seals 25, 26, 27 may be adjusted according to floor type. One form of control is a manually-operated two-state latching mechanism. Other forms of control are possible, including an automatic adjustment to floor type.

Some other possible forms of the rotatable sealing element 40 are shown in Figures 6
20 and 7. Figure 6 shows a rotatable sealing element 40 comprising a core 44 with flexible/deformable radial elements 45 extending radially from the core 44. Radial elements 45 resemble blades or paddles. The blades 45 have the same, or similar, length as the core 44, so that the blades 45 across the full length of the core 44. The blades 45 extend a radial distance such that outer edges of the blades 45 can contact a floor surface. Optionally, the
25 blades 45 can extend a radial distance such that they sweep against the forward side 52 of the shielding member 50 and the part 13 of the housing hood which surrounds the upper portion of the rotatable element 40. The blades 45 sweep larger debris into the cleaner head whilst maintaining a seal to the surface to be cleaned. In this example, the seal 48 may be provided, or may be omitted, as the blades provide a seal to the housing. A scraper may be
30 provided, or may be omitted.

Figure 7 shows a rotatable sealing element 40 which is a hybrid of the designs of Figures 3 and 6. A roller 46 (e.g. of resiliently deformable material) has a smaller diameter compared to the one shown in Figure 3. Radial elements 47 project radially beyond an outer
35 surface of the roller 46. The radial elements 47 will be called splines. Outer edges of the splines 47 can contact a floor surface. Optionally, the splines 47 can extend a radial distance such that they sweep against the forward side 52 of the shielding member 50 and the part 13

of the housing hood which surrounds the upper portion of the rotatable element 40. The splines 47 sweep larger debris into the cleaner head whilst maintaining a seal to the surface to be cleaned. The roller 46 can deform to accommodate larger debris and/or uneven floor surfaces. In this example, the splines are spaced sufficiently regularly such that one spine is always forming a seal. In this example, the seal 48 may be provided, or may be omitted, as the splines provide a seal to the housing. A scraper may be provided, or may be omitted.

Figures 8 and 9 show the cleaner head 10 on different types of floor surface. Figure 8 shows the cleaner head 10 on a non-porous floor surface, such as a hard floor (e.g. wood floor, concrete, linoleum, tiles). Figure 9 shows the cleaner head 10 on a porous floor surface, such as carpet. Referring first to Figure 8, the lower surface 12 of the housing of the cleaner head is spaced a small distance above the non-porous floor surface. This spacing is achieved by a combination of: the wheels 16 at the rear of the housing; the auxiliary roller 51; and the rotatable sealing element 40. As described previously, with reference to Figure 4, debris can enter the cleaner head via two possible routes: (i) a route via the rotatable sealing element 40; and (ii) a route via the underside of the agitator 60 and suction of suction inlet 20 (optionally with additional agitation by beater bar 60). A seal is maintained around a perimeter of the cleaner head 10 by the rotatable sealing element 40 (front) and brush seals (rear, sides). The rear brush seal 26 is shown in Figure 8.

Figure 9 shows the cleaner head 10 on a carpeted floor surface. The lower face 12 of the housing contacts the surface. In effect, the lower face 12 rides along the floor surface. Wheels 16, auxiliary roller 51 and the rotatable sealing element 40 sink into the carpet. Optionally, the brush seals 26 can retract, as shown in Figure 9 or if they are static can compress into the carpet. The agitator 60 and can agitate the carpet pile by beating the carpet to effectively release dirt and debris, rotating at high speeds of up to 20000 RPM. As described previously, with reference to Figure 4, debris can enter the cleaner head via two possible routes: (i) a route via the rotatable sealing element 40; and (ii) a route via the underside of the agitator 60 and suction of suction inlet 20 (optionally with additional agitation by beater bar 60)

The vacuum cleaner 1 may be battery powered (cordless) or mains powered.

Some other possible alternative examples will now be described.

Referring again to Figure 3, an upper part of the rotatable sealing element 40 is covered by the housing 11. In another example, the upper part of the rotatable sealing element 40 may be exposed. The housing may extend as far as, or just beyond, the seal 48.

Referring again to Figure 4, there is a portion 55 of the rotatable sealing element 40 between the top 54 of the shield and below the seal/scraper 48 which is exposed to suction in the suction passageway 20A. This portion 55 of the rotatable sealing element 40 is close to

the suction passageway 20A. In another example, the portion 55 of the rotatable element 40 may be located further away from the suction passageway 20A. A downward incline (chute) may connect the portion 55 of the rotatable sealing element 40 to the suction passageway 20A.

5 Figure 10A and 10B shows an example of the cleaner head 10 with an alternative arrangement. The shielding member 50 and shielding member roller 51 are not present and a wider pathway to the suction passageway 20A is formed between the agitator 60 and sealing element 40. The ability seal to hard floors and agitate carpet pile is maintained all be it to a lesser degree but complexity and cost is reduced. In Figure 10A the rotation of the
10 agitator is anticlockwise towards the suction passageway 20A. Figure 10B shows an example of an agitator that can rotate in either direction, clockwise and anti-clockwise, in an oscillating fashion. This can be of benefit in reducing noise; as the agitator is not continuously rotating at high speed the beating noise of the agitator can be reduced, whilst maintaining the ability to agitate the carpet and guide dirt towards the suction passageway 20A. This can be
15 achieved for example with a motor that can be switched in direction, use of a solenoid to oscillate the agitator or any other suitable means.

 Figure 11A, 11B, 11C and 11D show examples of possible agitator construction. Figure 11A shows the agitator embodied in Figures 3 to 10. The agitator is constructed from a core 60, members 63 protrude from the core that are resilient to deformation so as to exert
20 a parting force on carpet pile and are made from any suitable material such as nylon, or polypropylene bristles/filaments. Figure 11B shows a helical arrangement of agitator filaments which has the benefit of offering a lower resistance to turn when parting through the carpet pile. Figures 11C and 11D show an agitator constructed of a core 60 and blades 64 and 64A which extend the length of the core in helical and linear fashions. The blades can be
25 constructed from any material that are resilient to deformation so as to exert a parting force on carpet pile such as rubber, plastic, steel or a composite material. The blades 64 and 64A in Figures 11C and 11D could equally be interspersed across length of the core 60. The blades 64 and 64A shown in 11C and 11D could equally be combined with the members 63 in a hybrid design.

30 It will be understood that the benefits and advantages described above may relate to one embodiment or may relate to several embodiments. The embodiments are not limited to those that solve any or all of the stated problems or those that have any or all of the stated benefits and advantages.

 Any reference to 'an' item refers to one or more of those items. The term 'comprising'
35 is used herein to mean including the method blocks or elements identified, but that such blocks or elements do not comprise an exclusive list and a method or apparatus may contain additional blocks or elements.

The steps of the methods described herein may be carried out in any suitable order, or simultaneously where appropriate. Additionally, individual blocks may be deleted from any of the methods without departing from the spirit and scope of the subject matter described herein. Aspects of any of the examples described above may be combined with aspects of
5 any of the other examples described to form further examples without losing the effect sought.

It will be understood that the above description of a preferred embodiment is given by way of example only and that various modifications may be made by those skilled in the art. Although various embodiments have been described above with a certain degree of particularity, or with reference to one or more individual embodiments, those skilled in the art
10 could make numerous alterations to the disclosed embodiments without departing from the scope of this invention.

CLAIMS

1. A cleaner head for a vacuum cleaner comprising:
a housing configured to be movable across a floor surface, the housing having a
5 lower face;
a suction inlet defined in the lower face of the housing;
a suction passageway through the housing, the suction passageway in fluid
communication with the suction inlet;
a rotatable sealing element located at a front of the housing, the rotatable sealing
10 element having a rotational axis which is parallel to the lower face of the cleaner head, the
housing at least partially surrounding the rotatable sealing element;
an agitator positioned rearwards of the rotatable sealing element;
wherein the suction passageway is located between the agitator and rotatable sealing
element.
15
2. A cleaner head according to claim 1 comprising a shielding member located between
the agitator and the rotatable sealing element, wherein the suction passageway is in fluid
communication with a portion of the rotatable sealing element above the shielding member.
- 20 3. A cleaner head according to any one of the preceding claims, wherein the shielding
member extends to the lower face, the shielding member configured to shield a rearward side
of the rotatable sealing element, proximate the lower face of the cleaner head.
4. A cleaner head according to claim 2 or 3 comprising a roller mounted rotatably with
25 respect to the shielding member, the roller configured to provide a seal between the shielding
member and a floor surface.
5. A cleaner head according to any one of claims 2 to 4 wherein the shielding member
has a surface on the rearward side configured to guide fluid flow away from rearward side of
30 the rotatable sealing element, proximate the lower face of the cleaner head.
6. A cleaner head according to any one of claims 2 to 5 wherein the shielding member
has a surface on the forward side which is coaxial with the rotational axis of the rotatable
sealing element.
35
7. A cleaner head according to claim 6 wherein there is a clearance between the
surface on the forward side of the shielding member and an outer surface of the rotatable
sealing element.

8. A cleaner head according to claim 7 wherein the clearance is less than 3mm, and optionally less than 1mm.
- 5 9. A cleaner head according to any one of claims 2 to 8 comprising an agitator housing which partially encloses the agitator, the agitator housing having an opening on a front side, the opening defined by a lip of the agitator housing, wherein the shielding member extends to a height which is substantially the same as the lip of the agitator housing.
- 10 10. A cleaner head according to any one of the preceding claims wherein the rotatable sealing element comprises an outer layer of deformable material.
11. A cleaner head according to claim 10 wherein the deformable material is resiliently deformable material.
- 15 12. A cleaner head according to claim 10 or 11 wherein the deformable material is closed cell foam.
13. A cleaner head according to claim 11 or 12 wherein the rotatable sealing element
20 comprises a plurality of flexible radially-extending blades.
14. A cleaner head according to any one of claims 1 to 9 wherein the rotatable sealing element comprises a plurality of flexible, radially-extending blades.
- 25 15. A cleaner head according to any one of the preceding claims comprising a drive configured to rotate the rotatable sealing element independently of movement of the cleaner head across a surface.
16. A cleaner head according to claim 15 wherein the drive is a motor.
- 30 17. A cleaner head according to any one of the preceding claims comprising a seal between a side face of the rotatable sealing element and the housing.
18. A cleaner head according to any one of the preceding claims comprising a brush seal
35 located at a perimeter of the cleaner head on at least one of: side edges of the cleaner head; rear edge of the cleaner head.
19. A cleaner head according to claim 18 wherein the brush seal is adjustable in height.

20. A cleaner head according to any one of the preceding claims comprising a sealing element to provide a seal between the housing and the rotatable sealing element.
- 5 21. A cleaner head according to claim 20 wherein the sealing element is located on a rearward side of the rotatable sealing element, within the housing.
22. A cleaner head according to claim 20 or 21 wherein the sealing element is configured to scrape debris from an outer surface of the rotatable sealing element.
- 10 23. A cleaner head according to any one of claims 1 to 21 comprising a scraper which is configured to scrape debris from an outer surface of the rotatable sealing element.
24. A cleaner head according to any one of the preceding claims where the agitator comprises a plurality of radially-extending brush filaments.
- 15 25. A cleaner head according to any one of the preceding claims where the agitator is a beater bar.
- 20 26. A cleaner head according to any one of claims 1 to 23 where the agitator comprises a plurality of radially-extending blades.
27. A cleaner head according to any one of the preceding claims comprising a drive configured to rotate the agitator independently of movement of the cleaner head across a surface.
- 25 28. A cleaner head according to claim 27 where the agitator is rotated at a speed of up to 20000 RPM.
- 30 29. A cleaner head according to any one of claims 1 to 26 where the agitator is oscillated about a longitudinal axis of the agitator.
30. A vacuum cleaner comprising a cleaner head according to any one of the preceding claims.
- 35

AMENDMENTS TO THE CLAIMS HAVE BEEN FILED AS FOLLOWS

CLAIMS

1. A cleaner head for a vacuum cleaner comprising:
a housing configured to be movable across a floor surface, the housing having a
5 lower face;
a suction inlet defined in the lower face of the housing;
a suction passageway through the housing, the suction passageway in fluid
communication with the suction inlet;
a rotatable sealing element located at a front of the housing, the rotatable sealing
10 element having a rotational axis which is parallel to the lower face of the cleaner head, the
housing at least partially surrounding the rotatable sealing element;
an agitator positioned rearwards of the rotatable sealing element and comprising a
plurality of radially extending brush filaments;
wherein the suction passageway is located between the agitator and rotatable sealing
15 element.
2. A cleaner head according to claim 1 comprising a shielding member located between
the agitator and the rotatable sealing element, wherein the suction passageway is in fluid
communication with a portion of the rotatable sealing element above the shielding member.
20
3. A cleaner head according to claim 2, wherein the shielding member extends to the
lower face, the shielding member configured to shield a rearward side of the rotatable sealing
element, proximate the lower face of the cleaner head.
- 25 4. A cleaner head according to claim 2 or 3 comprising a roller mounted rotatably with
respect to the shielding member, the roller configured to provide a seal between the shielding
member and a floor surface.
5. A cleaner head according to any one of claims 2 to 4 wherein the shielding member
30 has a surface on its rearward side configured to guide fluid flow away from the rearward side
of the rotatable sealing element, proximate the lower face of the cleaner head.
6. A cleaner head according to any one of claims 2 to 5 wherein the shielding member
has a surface on its forward side which is coaxial with the rotational axis of the rotatable
35 sealing element.

05 10 17

7. A cleaner head according to claim 6 wherein there is a clearance between the surface on the forward side of the shielding member and an outer surface of the rotatable sealing element.

5 8. A cleaner head according to claim 7 wherein the clearance is less than 3mm, and optionally less than 1mm.

9. A cleaner head according to any one of claims 2 to 8 comprising an agitator housing which partially encloses the agitator, the agitator housing having an opening on a front side,
10 the opening defined by a lip of the agitator housing, wherein the shielding member extends to a height which is substantially the same as the lip of the agitator housing.

10. A cleaner head according to any one of the preceding claims wherein the rotatable sealing element comprises an outer layer of deformable material.

15

11. A cleaner head according to claim 10 wherein the deformable material is resiliently deformable material.

20

12. A cleaner head according to claim 10 or 11 wherein the deformable material is closed cell foam.

13. A cleaner head according to claim 11 or 12 wherein the rotatable sealing element comprises a plurality of flexible radially-extending blades.

25

14. A cleaner head according to any one of claims 1 to 9 wherein the rotatable sealing element comprises a plurality of flexible, radially-extending blades.

30

15. A cleaner head according to any one of the preceding claims comprising a drive configured to rotate the rotatable sealing element independently of movement of the cleaner head across a surface.

16. A cleaner head according to claim 15 wherein the drive is a motor.

35

17. A cleaner head according to any one of the preceding claims comprising a seal between a side face of the rotatable sealing element and the housing.

18. A cleaner head according to any one of the preceding claims comprising a brush seal located at a perimeter of the cleaner head on at least one of: side edges of the cleaner head; rear edge of the cleaner head.

5 19. A cleaner head according to claim 18 wherein the brush seal is adjustable in height.

20. A cleaner head according to any one of the preceding claims comprising a sealing element to provide a seal between the housing and the rotatable sealing element.

10 21. A cleaner head according to claim 20 wherein the sealing element is located on a rearward side of the rotatable sealing element, within the housing.

22. A cleaner head according to claim 20 or 21 wherein the sealing element is configured to scrape debris from an outer surface of the rotatable sealing element.

15

23. A cleaner head according to any one of claims 1 to 21 comprising a scraper which is configured to scrape debris from an outer surface of the rotatable sealing element.

20 24. A cleaner head according to any one of the preceding claims where the agitator is a beater bar.

25 25. A cleaner head according to any one of the preceding claims comprising a drive configured to rotate the agitator independently of movement of the cleaner head across a surface.

25

26. A cleaner head according to claim 25 where the agitator is rotated at a speed of up to 20000 RPM.

30 27. A cleaner head according to any one of claims 1 to 24 where the agitator is oscillated about a longitudinal axis of the agitator.

28. A vacuum cleaner comprising a cleaner head according to any one of the preceding claims.



Application No: GB1608295.0

Examiner: Rhodri Evans

Claims searched: 1-30

Date of search: 27 October 2016

Patents Act 1977: Search Report under Section 17

Documents considered to be relevant:

Category	Relevant to claims	Identity of document and passage or figure of particular relevance
X	1, 10-16, 24-30	GB 2520549 A (Hoover) All figures and lines 12-14 of page 8.
X	1, 10-12, 15, 16, 24, 25, 27-30	BE 905711 A1 (Keyser) figure 1 and WPI abstract accession number 1987-079915.

Categories:

X	Document indicating lack of novelty or inventive step	A	Document indicating technological background and/or state of the art.
Y	Document indicating lack of inventive step if combined with one or more other documents of same category.	P	Document published on or after the declared priority date but before the filing date of this invention.
&	Member of the same patent family	E	Patent document published on or after, but with priority date earlier than, the filing date of this application.

Field of Search:

Search of GB, EP, WO & US patent documents classified in the following areas of the UKC^X :

--

Worldwide search of patent documents classified in the following areas of the IPC

A47L

The following online and other databases have been used in the preparation of this search report

WPI, EPODOC

International Classification:

Subclass	Subgroup	Valid From
A47L	0009/04	01/01/2006
A47L	0009/02	01/01/2006