

*W. Dripps,  
Water Wheel.*

*N<sup>o</sup> 3,961.*

*Patented Apr. 9 1861.*

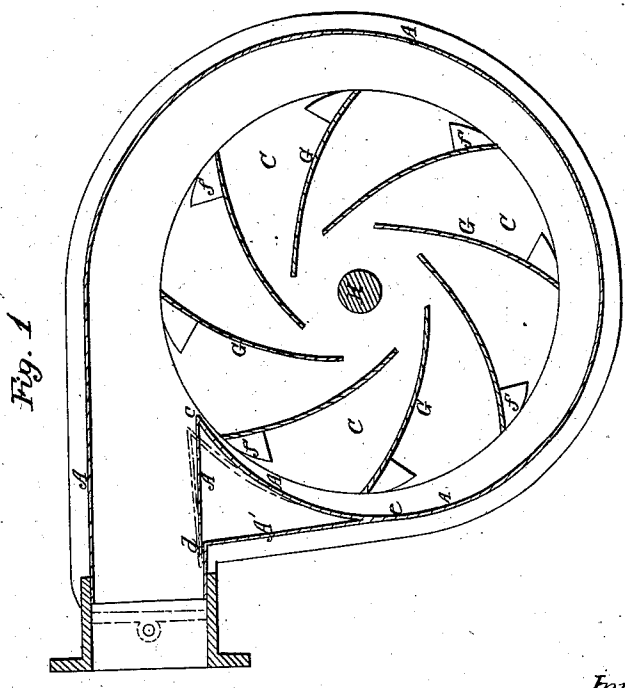
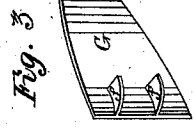
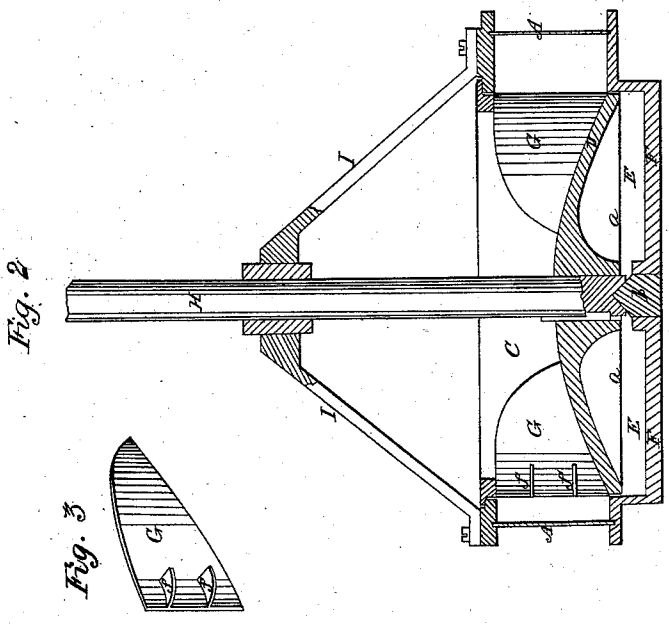

*Witnesses:  
E. Cohen  
J. Wash.*

*Inventor:  
William Dripps  
By atty A. B. Stoughton*

# UNITED STATES PATENT OFFICE.

WILLIAM DRIPPS, OF COATESVILLE, PENNSYLVANIA.

## WATER-WHEEL.

Specification of Letters Patent No. 31,961, dated April 9, 1861.

*To all whom it may concern:*

Be it known that I, WILLIAM DRIPPS, of Coatesville, in the county of Chester and State of Pennsylvania, have invented certain  
5 new and useful Improvements in Water-Wheels; and I do hereby declare the following to be a full, clear, and exact description of the same, reference being had to the accompanying drawings, making a part of this  
10 specification, in which —

Figure 1 represents a horizontal section taken through the wheel and its case. Fig. 2 represents a vertical section through the same, and Fig. 3 represents one of the buckets detached from the wheel, to show the  
15 flanges upon it, said bucket and flanges being shown in perspective.

Similar letters of reference where they occur in the separate figures denote like parts  
20 of the wheel in all the drawings.

My invention consists first in a close chamber under the wheel, into which the water is drawn, and which raises the wheel and eases it upon its lower step or support; and it further  
25 consists in forming that end of the spiral casing which most nearly approaches the perimeter of the wheel, into a spring, and carrying it back to form one of the walls of the inlet water way for the purpose of  
30 allowing said part to yield to any hard substance which may be carried into, and around with, the wheel; and it further consists in providing one or more flanges upon the face of the buckets, to prevent the water  
35 from rising upon the buckets, when a small quantity, or a low head is all that the stream will afford.

To enable others skilled in the art to make and use my invention, I will proceed to describe the same with reference to the drawings.  
40

A represents the outer case, of a spiral water way B, in which is placed a wheel C. The bottom of the wheel (D), may be convex, and there may be a recess E, in the bottom of the water case F, so that the two shall form a chamber *a* between them, into which there is no ingress or egress except  
45 through the joint between them. It is obvious that the bottom of the wheel (D), may be flat and still leave the chamber *a*, underneath it. I find that, in the use of such a chamber, when the wheel is in motion, that  
50 the water will be drawn into it under pres-

sure, so as actually like a ram to lift the  
55 wheel, and take much of its weight from the step *b*. The water appears to be regularly pumped into this chamber *a*, under pressure, and by its force to raise up the wheel.

The spiral casing A, when it arrives at  
60 the point *c*, where it meets the circumference of the wheel is bent short around, and extends backward and forms one of the walls of the inlet water way. Its end *d* is not fastened, but is free to move, as shown  
65 in red in Fig. 1, the object being to allow any hard substance to pass through without breaking the wheel. A false rim A', takes off the sharp angle, and closes the water way, or the part A', may be a part of the  
70 spiral rim, and the part *c, d, e*, that forms the spring portion, may be fastened to A'.

I am aware that, a hinge and a spring made in separate pieces have been used at this point, but the least stick, or sand or gravel,  
75 clogs the hinge, and it is useless. I make my spring or yielding portion, a part of the case itself and there is no place where it can be clogged or choked, besides its being  
80 much cheaper than a hinge and more re-

liable. The buckets G, are made as represented more particularly in Fig. 3, and upon that side of them against which the water strikes I arrange one, two, or more flanges *f*, the  
85 object, of which flanges, is that when a low head, or small quantity of water, is only had, that it will not expend itself in rising up on the buckets, but be kept down and against the buckets by these flanges.  
90

The water escapes on top of the wheel, it being closed at the bottom to procure the tight or comparatively tight water chamber underneath the wheel. The rim of the bottom part D, of the wheel should be made  
95 to run as close to the case or bottom of the case as possible without actual contact that would produce friction, and the bottom of the wheel, and the bottom of the case being both tight the water can only find ingress  
100 and egress to and from the chamber, at the joint between them.

I am aware that water has been carried under a wheel by a pipe or tube, to raise the weight of the toe of the wheel. I use only  
105 what may be termed the leakage of the joint to accomplish this purpose.

H, is the shaft of the wheel and I, brack-

ets for forming an upper support for the shaft.

Having thus fully described my invention, what I claim is—

5 1. In combination with a spiral cased water wheel the making of a water chamber between the bottom of the wheel, and the bottom of the case, that is supplied by ingress at the joint, for the purpose of raising  
10 the toe of the wheel, as set forth.

2. The converting of that part of the casing *e, e*, into a spring, so that it, as well as the continuation of it *d*, may yield to any

hard substance that may get into the wheel, substantially as described. 15

3. In combination with the buckets of a water wheel, the flanges *f*, for the purpose of preventing the water, when there is but a small supply from rising up on the bucket, and thus wasting much of its force substantially as described. 20

WILLIAM DRIPPS.

Witnesses:

A. B. STOUGHTON,  
E. COHEN.