



US00D605739S

(12) **United States Design Patent**
Henry et al.

(10) **Patent No.:** **US D605,739 S**

(45) **Date of Patent:** **** Dec. 8, 2009**

(54) **GASKET**

(75) Inventors: **Vance W. Henry**, Easton, PA (US);
Scott D. Madara, Nazareth, PA (US)

(73) Assignee: **Victaulic Company**, Easton, PA (US)

(**) Term: **14 Years**

(21) Appl. No.: **29/331,382**

(22) Filed: **Jan. 23, 2009**

(51) **LOC (9) Cl.** **23-01**

(52) **U.S. Cl.** **D23/269**

(58) **Field of Classification Search** D23/259-269,
D23/249; 137/516.13-516.27; 251/368;
277/602, 608, 625-626; 285/104-105, 337
See application file for complete search history.

(56) **References Cited**

U.S. PATENT DOCUMENTS

| | | | | |
|--------------|------|---------|-----------------|---------|
| 1,899,695 | A | 2/1933 | Johnson | |
| 3,304,050 | A | 2/1967 | Fawkes | |
| 3,351,352 | A | 11/1967 | Blakely et al. | |
| 3,540,696 | A | 11/1970 | Fawkes et al. | |
| 3,544,066 | A | 12/1970 | Fawkes et al. | |
| 3,834,744 | A * | 9/1974 | Masatchi | 277/607 |
| 3,993,332 | A * | 11/1976 | Borodin et al. | 285/94 |
| 6,312,025 | B1 * | 11/2001 | Wolfsdorf | 285/369 |
| 6,938,879 | B2 | 9/2005 | Bancroft et al. | |
| D526,705 | S | 8/2006 | Wortmann et al. | |
| D527,445 | S | 8/2006 | Wortmann et al. | |
| D529,145 | S | 9/2006 | Wortmann et al. | |
| D529,146 | S | 9/2006 | Wortmann et al. | |
| D534,253 | S * | 12/2006 | Sandman et al. | D23/269 |
| D536,071 | S | 1/2007 | Wortmann et al. | |
| 2005/0253383 | A1 | 11/2005 | Gibb et al. | |
| 2008/0018057 | A1 * | 1/2008 | Gibb et al. | 277/608 |
| 2008/0272595 | A1 * | 11/2008 | Gibb et al. | 285/337 |

* cited by examiner

Primary Examiner—T. Chase Nelson
Assistant Examiner—Eric L Goodman
(74) *Attorney, Agent, or Firm*—Ballard Spahr LLP

(57) **CLAIM**

I claim the ornamental design for a gasket, as shown and described.

DESCRIPTION

FIG. 1 is an isometric view of my design for a gasket;
 FIG. 2 is a front view of the design for the gasket shown in FIG. 1, the rear view being identical;
 FIG. 3 is a left side view of the design for the gasket shown in FIG. 1, the right side view and the top and bottom views being identical;
 FIG. 4 is a cross sectional view along line 4—4 of the design for the gasket as shown in FIG. 2;
 FIG. 5 is an isometric view of a second embodiment of my design for a gasket;
 FIG. 6 is a front view of the design for the gasket shown in FIG. 5, the rear view being identical;
 FIG. 7 is a left side view of the design for the gasket shown in FIG. 5, the right side view and the top and bottom views being identical;
 FIG. 8 is a cross sectional view along line 8—8 of the design for the gasket as shown in FIG. 6;
 FIG. 9 is an isometric view of a third embodiment of my design for a gasket;
 FIG. 10 is a front view of the design for the gasket shown in FIG. 9, the rear view being identical;
 FIG. 11 is a left side view of the design for the gasket shown in FIG. 9, the right side view and the top and bottom views being identical; and,
 FIG. 12 is a cross sectional view along line 12—12 of the design for the gasket as shown in FIG. 10.

1 Claim, 12 Drawing Sheets

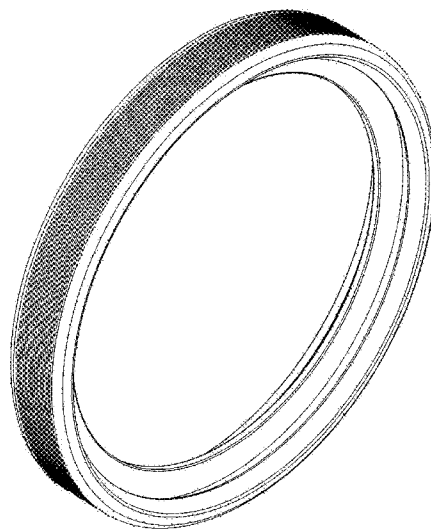

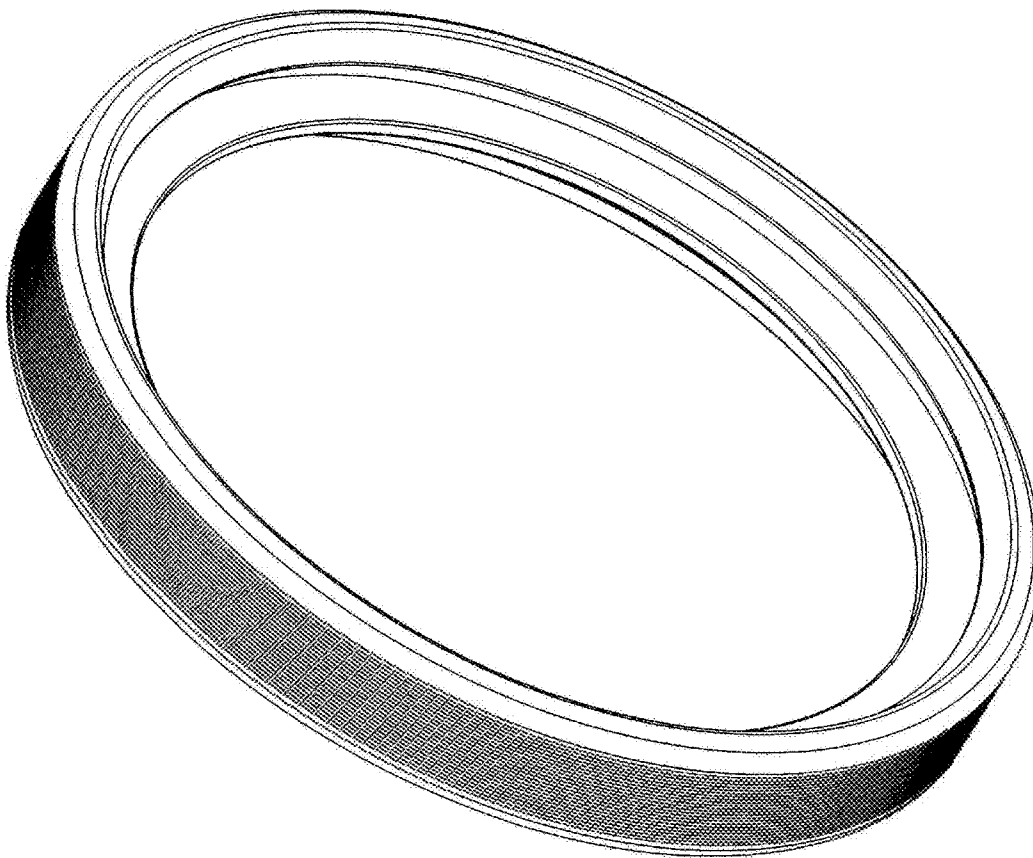

FIG.1

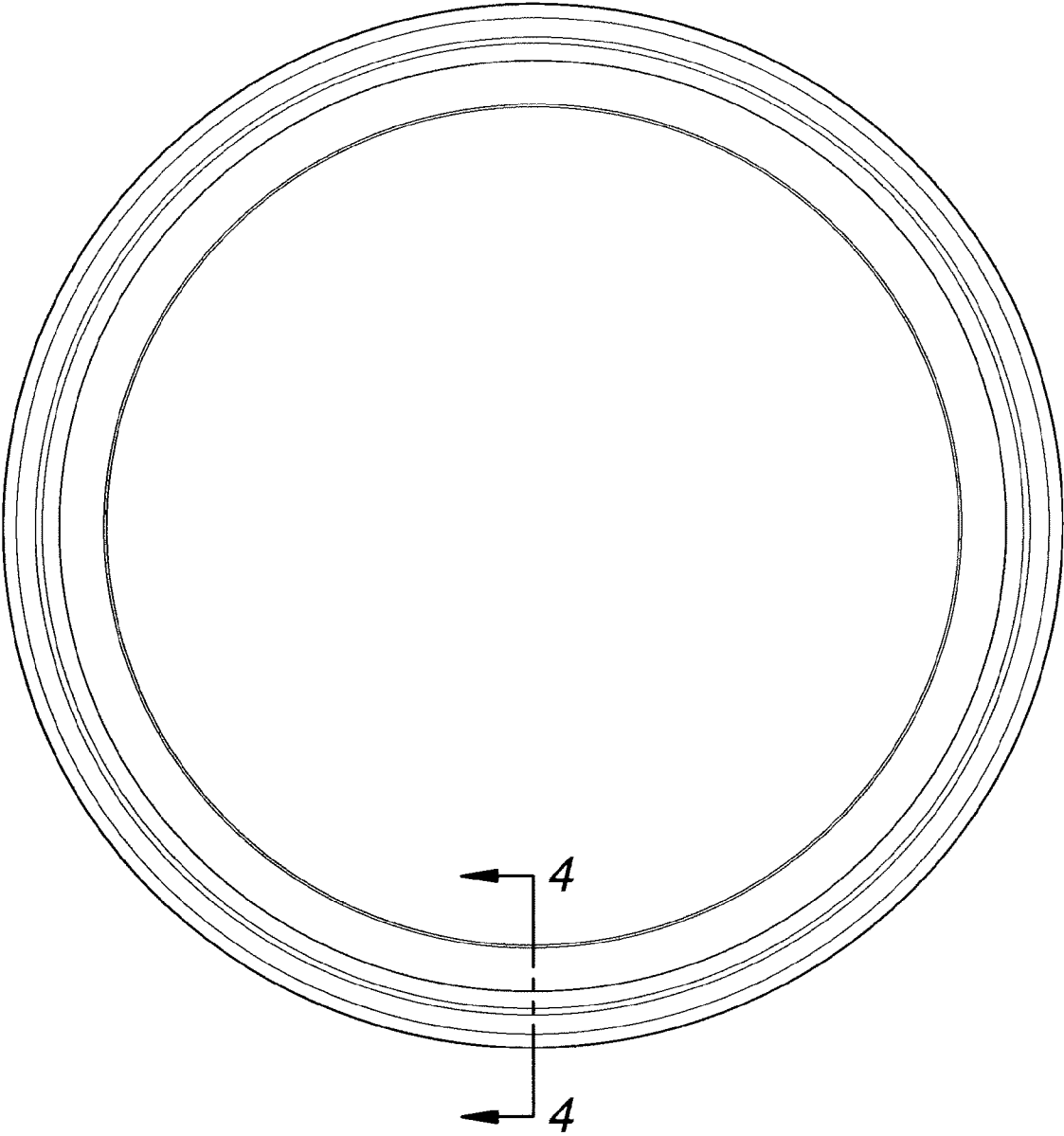

FIG. 2

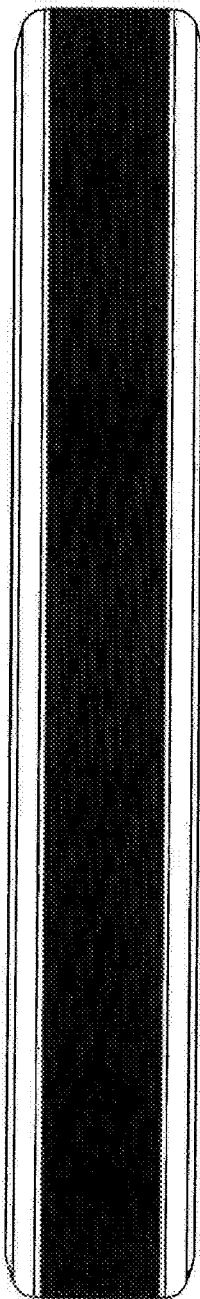

FIG.3

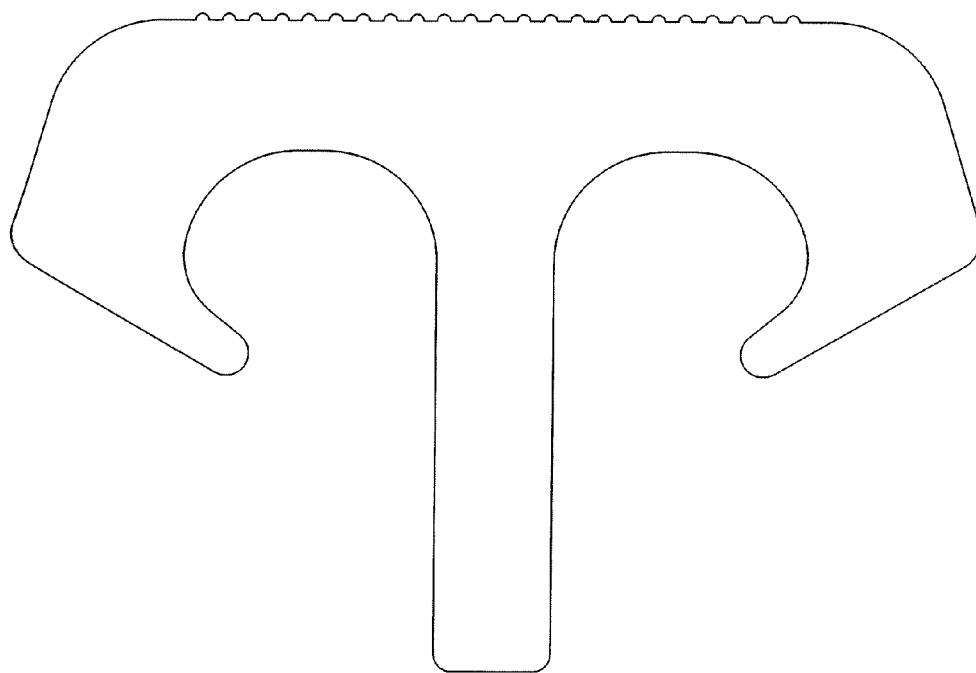

FIG.4

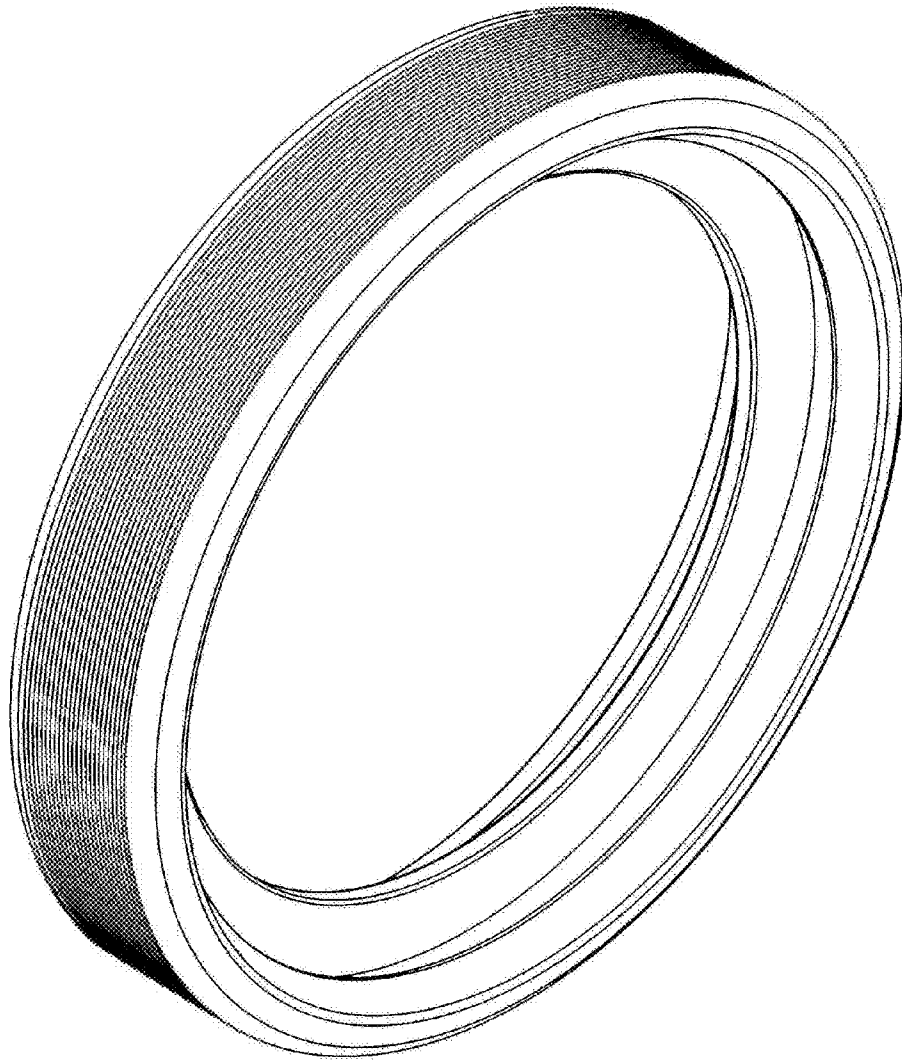

FIG. 5

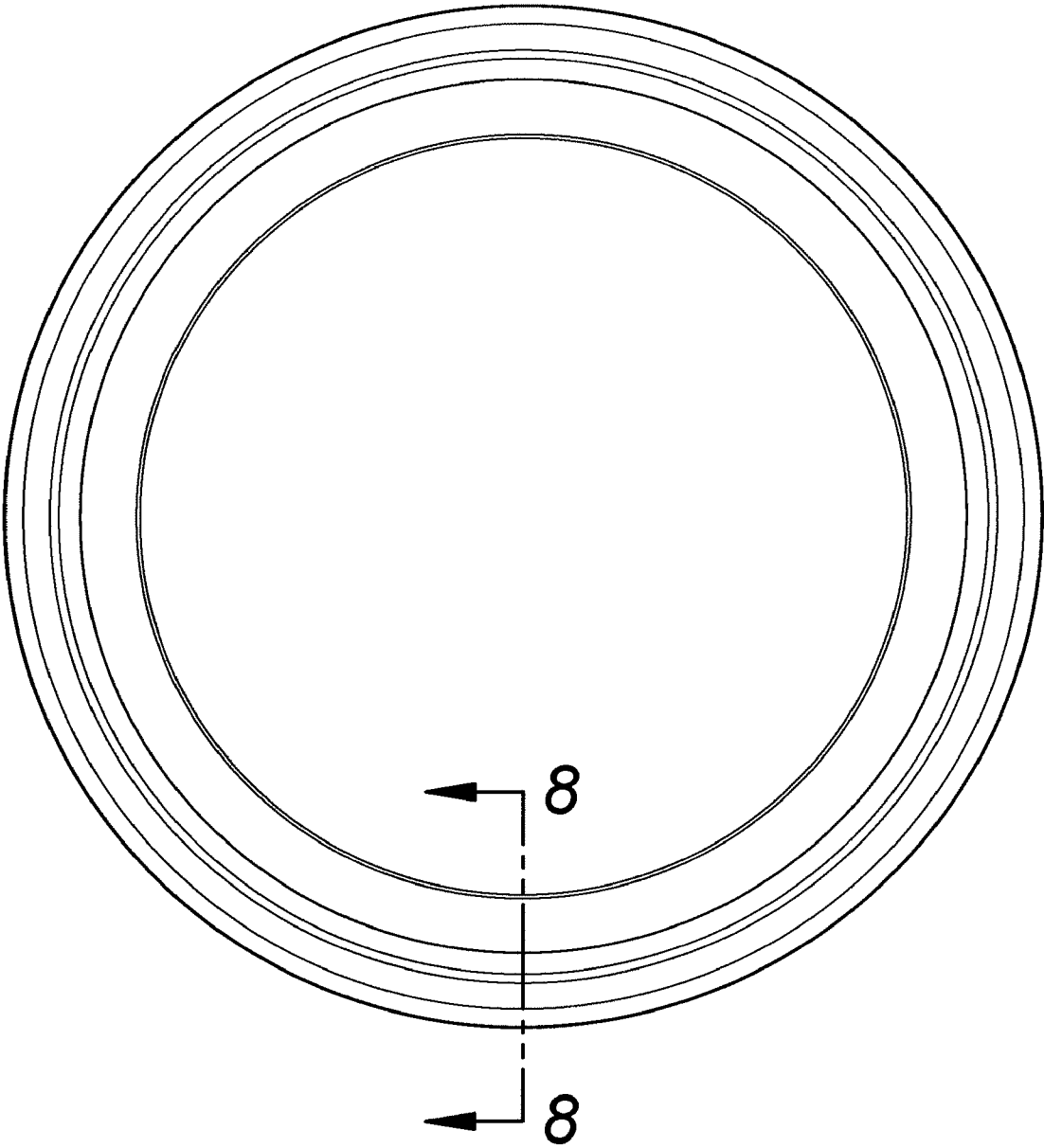

FIG. 6

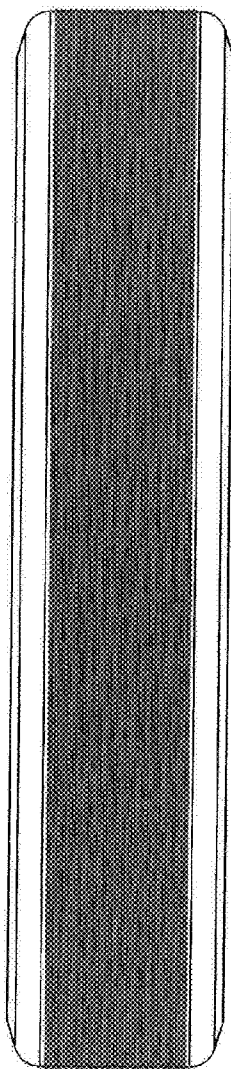

FIG. 7

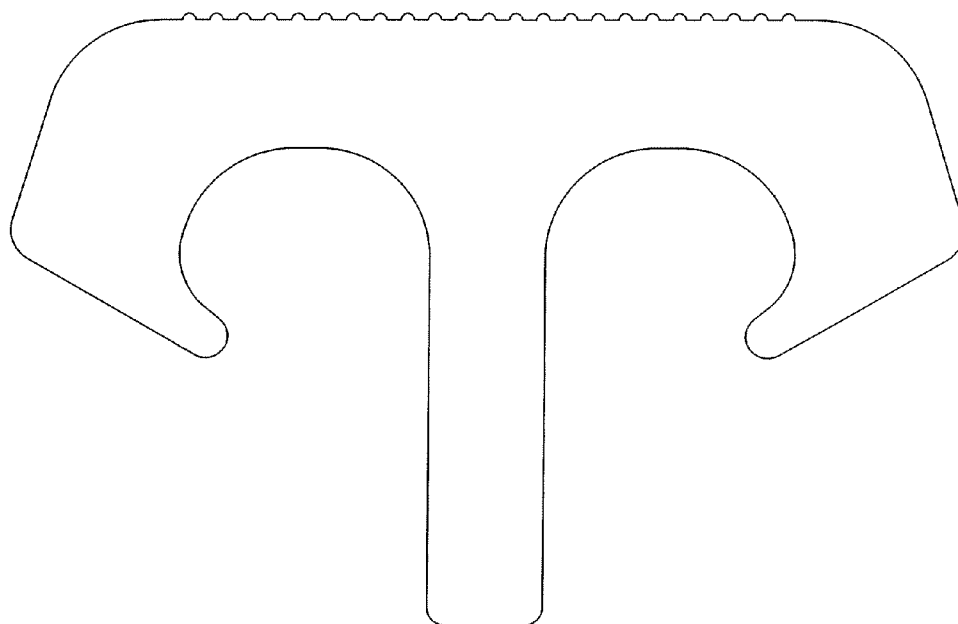

FIG. 8

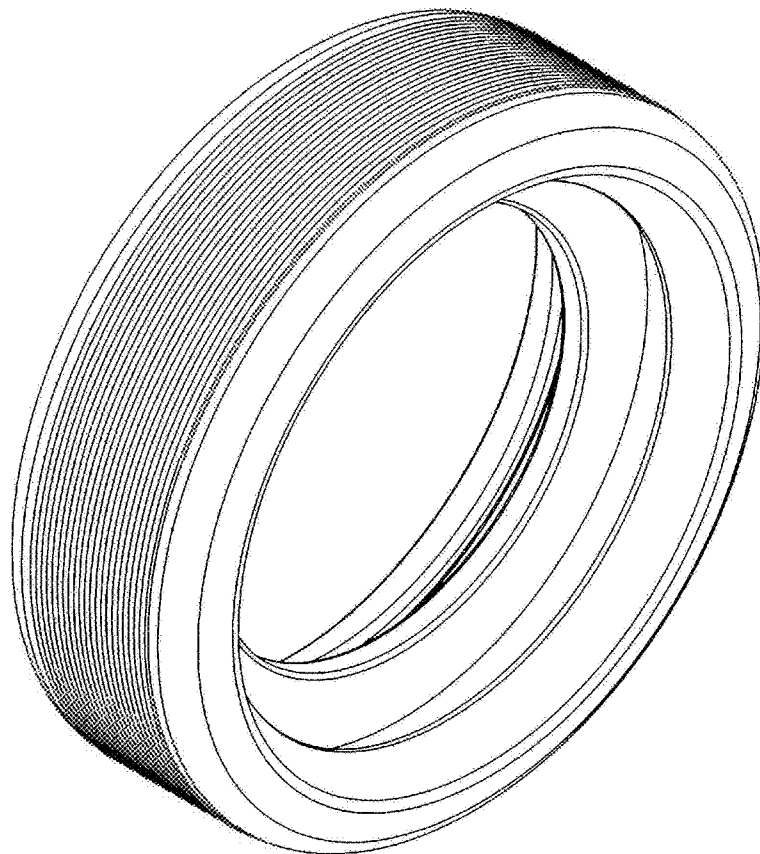

FIG. 9

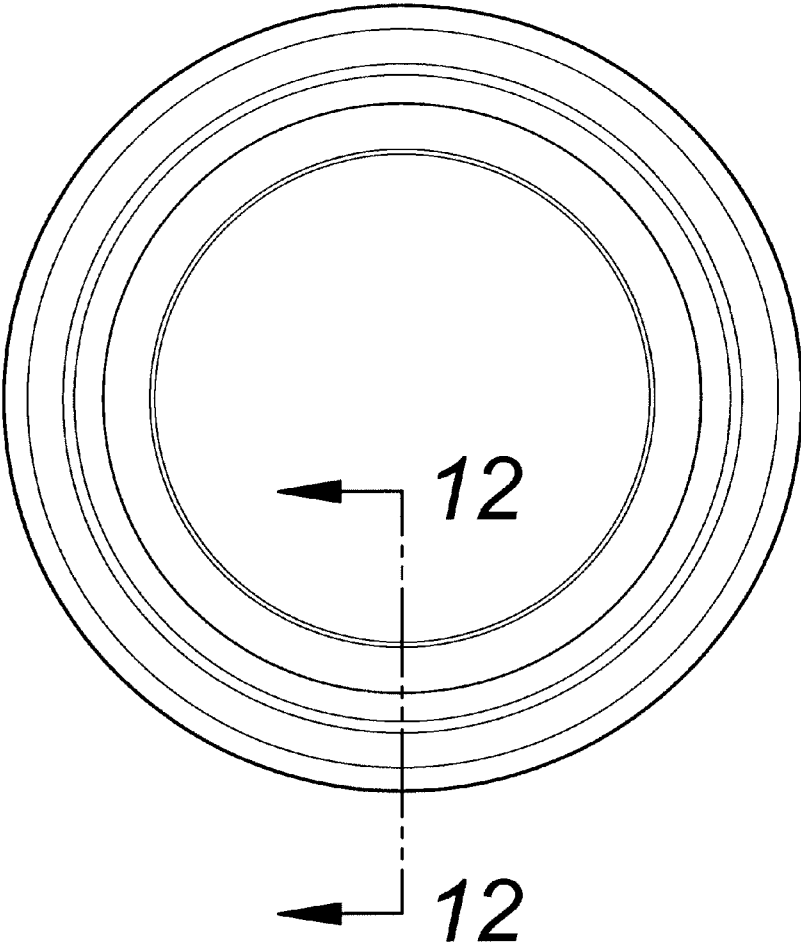

FIG. 10

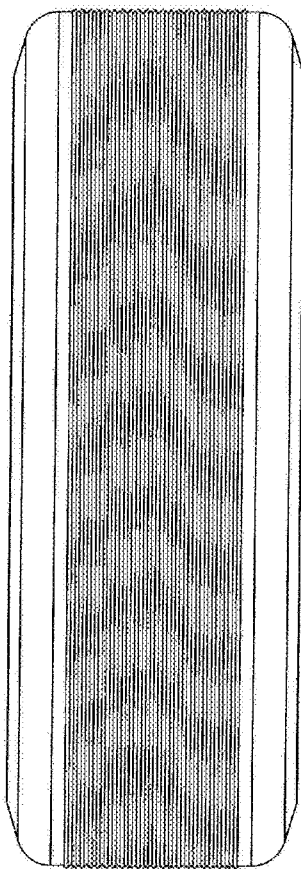

FIG. 11

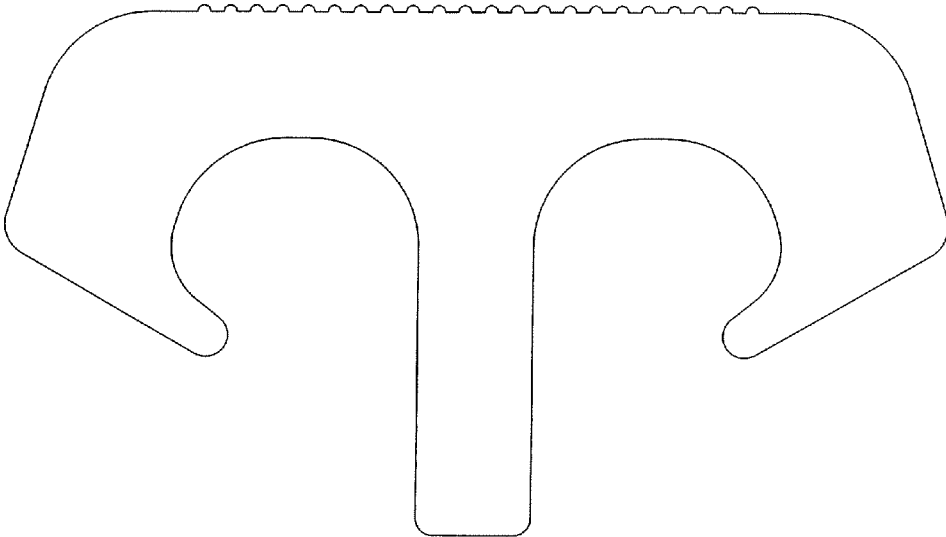

FIG. 12