



Europäisches Patentamt
 European Patent Office
 Office européen des brevets

Publication number:

**0 292 930
 A1**



EUROPEAN PATENT APPLICATION

Application number: **88108314.1**

Int. Cl. 4: **A61N 1/30**

Date of filing: **25.05.88**

Priority: **28.05.87 US 55518**

Date of publication of application:
30.11.88 Bulletin 88/48

Designated Contracting States:
AT BE CH DE ES FR GB GR IT LI LU NL SE

Applicant: **Drug Delivery Systems Inc.**
292 Madison Avenue
New York New York 10017(US)

Inventor: **Sibalis, Dan**
268 Hallock Road
Stony Brook, N.Y. 11790(US)

Representative: **Patentanwälte RUFF, BEIER**
und SCHÖNDORF
Neckarstrasse 50
D-7000 Stuttgart 1(DE)

Pulsating transdermal drug delivery system.

An electrophoretic/electro-osmotic transdermal drug delivery system for passing at least one drug, or therapeutic compound, through the skin (16) membrane of a patient by way of a drug reservoir (12) or gel for delivery to the systemic blood of a patient in selected, periodic pulsations. The system can be varied to accommodate various types of therapeutic compounds having varied characteristics and purposes. The system includes a current oscillator (28) that applies periodic electrical variations to the system in order to trigger rhythmical variations of the potential and resistance of the skin membrane so as to cause oscillatory electro-osmotic streaming of the liquid with the therapeutic compound across the skin membrane in synchronization with the oscillator to the systemic blood of the patient in response to the rhythmical variations. The oscillator causes the power source (22) to deliver a periodic pulsating current.

EP 0 292 930 A1

PULSATING TRANSDERMAL DRUG DELIVERY SYSTEM

Related U.S. Patent Applications

This application is related to my U.S. Patent Nos. 4,557,773, 4,622,031, and 4,640,689 and to my pending U.S. application entitled "Electrical Transdermal Drug Applicator", Serial No. 888,151, filed July 18, 1986.

Field of the Invention

The present invention relates to transdermal drug delivery, or drug applicator, systems and more particularly to electrophoretic transdermal drug delivery systems including electro-osmotic and iontophoretic systems that function by passing an electrical current through a drug patch.

Background of the Invention

Delivery of drugs to the systemic blood of a patient by means of an electrophoretic/electro-osmotic transdermal system is generally accomplished primarily through the sweat and sebaceous ducts and their respective glands. Some delivery is made through the stratum corneum, or horny layer. The stratum corneum, although very thin, is resistant to the passage of both electrical current and of liquids. The skin ducts cover an area of about one-thousandth of the stratum corneum.

The drug delivery system of my patent application entitled "Transdermal Drug Delivery System", serial No. 028679, filed March 20, 1987, describes a semi-dry drug patch and a selected current level delivered to the semi-dry patch that combine to limit liquid containing a drug from moving from the patch to the skin through the sweat and sebaceous ducts so as to starve the skin ducts of liquid and divert the current and the electro-osmotic delivery of the drug through the stratum corneum. A replenishment of the skin ducts with liquid occurs at periodic intervals by an electro-osmotic delivery of the drug solution through the skin ducts. An electrical oscillator can be added to the system so as to apply periodic current increases or pulsations in order to evacuate the skin ducts of water at intervals thus removing these electrical shunts from the delivery system.

The skin of a human is of the type having skin ducts, a type which is common to certain animals such as a horse, and so differs from the skins of animals not having skin ducts, such as a rabbit. Nevertheless, the human skin also has characteris-

tics taken in toto, not only separate duct and stratum corneum characteristics, and therefore can be considered as a unitary cell membrane.

An article that discusses electro-osmotic processes of living membranes is "Electrokinetic Membrane Processes in Relation to Properties of Excitable Tissues" by Torsten Teorell, published in Journal of General Physiology, 1959, Vol. 42, No. 4. A constant electrical current of a first value was applied to a porous, charged membrane corresponding to an excitable cell membrane. The result was a repetitive oscillatory process wherein the membrane at first periodically increased and decreased in resistance over approximate half-hour time periods in what the author described as oscillations. The decreased level of cell membrane resistance corresponded to oscillatory streaming of water solution across the cell membrane. The repetitive oscillations dampened after about an hour and about three oscillations. When a constant electrical current of a second value slightly greater than the first current value was applied to the same membrane, the repetitive oscillations became undamped, that is, the oscillations continued at about half-hour (in fact, slightly less) periods as long as the higher current continued to be applied. The "constant" electrical current in fact naturally increased and decreased in response to lower and higher resistance states of the membrane.

Two different types of drugs, or therapeutic compounds, can be delivered to the body. The therapeutic compound can be either a first type that corresponds to a naturally released body compound, such as a hormone as insulin, or a second type that is foreign to the body, such as nitroglycerin, a cardiovascular drug, an oncological drug, and an analgesic drug.

It is a phenomenon of many therapeutic compounds of the first type that when they are delivered to the systemic blood of the patient in an oscillatory, or pulsating mode, two different effects will occur depending upon the frequency of the drug delivery time relative to the natural delivery rhythm of the body. If a therapeutic compound of the first type is delivered in periodic variations which are applied in similar rhythms as the natural delivery rhythms of the body, the activity of the naturally released body compound will be simulated. If such a therapeutic compound is delivered in periodic electrical variations which are applied more often than the natural delivery rhythms of the body, the natural activity of the body compound will be inhibited or extinguished.

It is also a phenomenon of many therapeutic compounds of the second type that when they are

delivered to the systemic blood of the patient in an oscillatory mode as compared to a steady state mode of delivery, a different effect on the patient occurs as compared to the steady state mode. The oscillatory mode is selected in accordance with body requirements.

An example of a therapeutic compound of the first type that corresponds to a natural compound of the body is luteinising hormone-releasing hormone, or LHRH, which is also known as a gonadotrophin releasing hormone, or GnRH, and which controls production of testosterone in males and inducement of ovulation in females. LHRH is released in accordance with the natural rhythm of the body for approximately 6 minutes every hour. A transdermal drug delivery system that delivers LHRH in a steady state mode or at an increased frequency from the natural frequency extinguishes gonadotrophic secretion: That is, the production of either testosterone in males or ovulation in females ceases. On the other hand, a transdermal delivery system that delivers LHRH in a correct pulsating mode in accordance with the natural rhythm of the body simulates, or ensures, the mentioned processes. A natural compound of the body such as LHRH is released in accordance with a natural release rhythm of the body. In the case of LHRH and many other natural compounds there exist active analogues that have certain advantages over the particular natural compound. These active analogues are often used rather than the natural compounds to trigger or to inhibit or extinguish body responses.

An example of a drug of the second type that is foreign to the body is nitroglycerin. It is known that the steady state delivery of nitroglycerin to a heart patient via a transdermal drug delivery system results in a build-up of a tolerance to the drug by the body of the patient in less than 24 hours so that the drug is rendered useless for the 24-hour prophylaxis of stable angina pectoris. This matter is discussed in a paper entitled "Transdermal Nitroglycerin Patches in Angina Pectoris" by Udho Thadani et al., published in "Annals of Internal Medicine", October 1986, Vol. 105, No. 4.

It is known that a pulsating electrical current can be applied to an electrical circuit by various means, for example, by an oscillator in the circuit. Pulsations of potential or current in a an electrophoretic drug delivery system that are timed in accordance with an interplay of driving forces present in the drug delivery system including the skin as a transmembrane can accomplish timed drug deliveries that are more precise, reliable, and efficient than with delivery being made by the natural undamped rhythmical variations of the transmembrane potential and resistance caused by a selected steady state electrical current applied to

the system. The term pulsation as used herein is a periodic increase or decrease of a quantity, with the quantity herein having reference to the quantity of either potential or current or amount of a liquid with a drug transported across the transdermal skin membrane.

In general, the present invention is applicable to drug delivery systems which involve drugs or therapeutic compounds whose delivery is dependent upon timing, quantity, and direction of current flow.

It is an object of this invention to provide an electrophoretic/electro-osmotic transdermal drug delivery system that rhythmically delivers a therapeutic compound, or drug, to the systemic blood of a patient in response to application of current pulsations to the system which is otherwise devoid of current.

It is another object of this invention to provide an electrophoretic/electro-osmotic transdermal drug delivery system that rhythmically delivers a therapeutic compound to the systemic blood of a patient by application of positive current pulsations with a negative current being alternately applied to the system.

It is another object of this invention to provide an electrophoretic/electro-osmotic transdermal drug delivery system that rhythmically delivers a therapeutic compound to the systemic blood of a patient by application of negative current pulsations with a positive current being alternately applied to the system.

It is another object of this invention to provide an electrophoretic/electro-osmotic transdermal drug delivery system that rhythmically delivers a therapeutic compound to the systemic blood of a patient by application of positive current pulsations with a different positive current being alternately applied to the system.

It is another object of this invention to provide an electrophoretic/electro-osmotic transdermal drug delivery system that rhythmically delivers a therapeutic compound to the systemic blood of a patient by application of negative current pulsations with a different negative current being alternately applied to the system.

It is another object of this invention to provide an electrophoretic/electro-osmotic transdermal drug delivery system that rhythmically delivers a therapeutic compound to the systemic blood of a patient by application of current pulsations so as to reinforce the natural delivery rhythms of the body.

It is another object of this invention to provide an electrophoretic/electro-osmotic transdermal drug delivery system that rhythmically delivers a therapeutic compound to the systemic blood of a patient by application of current pulsations so as to inhibit or negate the natural delivery rhythms of the body.

In accordance with these and other objects there is described herein an electrophoretic:electro-osmotic transdermal drug delivery system for passing at least one therapeutic compound through the skin membrane of a patient by way of a drug patch for delivery to the systemic blood of a patient in selected, periodic pulsations. The system can be varied to accommodate various types of therapeutic compounds having varied characteristics and purposes. The system includes a current oscillator that applies periodic electrical variations to the system in order to trigger rhythmical variations of the potential and resistance of the skin membrane in synchronization with the oscillator so as to cause oscillatory electro-osmotic streaming of the liquid with the therapeutic compound across the skin membrane to the systemic blood of the patient in response to the rhythmical variations. The oscillator causes the power source to deliver a periodic pulsating current that alternates with periods of no current in the system or that alternates with periods of a different current than the pulsating current. The pulsating current can be applied for relatively short periods relative the periods of non-current or the periods of different current or can be applied for long periods relative the periods of non-current of the periods of different current. The different current can be either positive or negative current. During the periods of negative current the liquid with the therapeutic compound tends to be drawn from the skin membrane into the drug patch.

Brief Description of the Drawings

Figure 1 is a schematic representation of an electrophoretic drug delivery system having a drug patch in osmotic contact with the skin of a patient and including an oscillator that acts as a switch for the battery in the system;

Figure 2 is a model graph that illustrates delivery of a therapeutic compound to the skin of a patient by application of a pulsating current to a system otherwise devoid of current in accordance with the system shown in Figure 1;

Figure 3 is a model graph that illustrates delivery of a therapeutic compound to the skin of a patient by both a positive current delivery and positive pulsating current delivery in accordance with the system shown in Figure 1;

Figure 4 is a schematic representation of an electrophoretic drug delivery system that supplies both a positive and a negative current to the drug patch and that includes two batteries of opposite polarity in parallel in the system and a switch for reversing the current flow so as to supply alternating positive and negative pulsations;

Figure 5 is a schematic representation of an electrophoretic drug delivery system that supplies both a positive and a negative current to the drug patch and that includes a polarity-reversing double-pole, double-throw switch so as to supply alternating positive and negative pulsations;

Figure 6 is a model graph that illustrates delivery of a therapeutic compound to the skin of a patient by alternating negative and positive pulsating current delivery;

Figure 7 illustrates in isolated cross-section an integral cell membrane that includes a semipermeable membrane joined with the cover of the drug reservoir in adhesive and osmotic contact with the skin so as to form a cell membrane integral with the skin; and

Figure 8 is a model graph that illustrates flow of drug solution across the skin in response to pulsating voltage application to the system.

Description of the Preferred Embodiment

Reference is now made in detail to the drawings wherein the numerals refer to the same or similar elements throughout.

An electrical schematic diagram of an electrophoretic drug delivery system in accordance with the present invention shown in Figure 1 includes a drug storage patch, shown for purposes of exposition as a reservoir 12, and an electrode 14 each in contact with the skin, or cell membrane, 16 of a patient. Reservoir 12 and electrode 14 are connected by conductors 18 and 20, respectively, to the positive and negative terminals, or poles, of a battery 22. Reservoir 12 includes a liquid suspension, or solution, 24 containing a therapeutic compound to be delivered to the systemic blood of the patient. Solution 24 is contained by a cover 25 and a semipermeable adhesive gel 26 integral with cover 25 and which is in contact with skin 16. The therapeutic compound to be delivered to the patient is shown by way of example to be stored in the membrane-sealed drug reservoir described, but the therapeutic compound could be stored in a gel, or matrix, holding the therapeutic compound in a liquid suspension, or solution, throughout. A timer, or oscillator, 28 is connected to the circuit. The timer or oscillator 28 causes current received from battery 22 to be applied as current pulsations to reservoir 12 at selected periodic, or rhythmical, intervals so that the liquid in solution 24 along with the therapeutic compound is transported from reservoir 12, which is in osmotic contact with skin 16, through skin 16 to the systemic blood of the patient in undamped oscillatory processes in response to the rhythmical applications of the current.

Oscillator 28 causes periodic electrical pulsa-

tions to be applied to the circuit and particularly to reservoir 12 so as to trigger rhythmical variations of the potential and resistance of skin membrane 16 in synchronization with oscillator 28 so as to cause oscillatory electro-osmotic streaming of the liquid with the drug from reservoir 12 across skin membrane 16 to the systemic blood of the patient in response to the mentioned rhythmical variations of skin membrane 16.

Figure 2 shows a model graph that illustrates a particular drug delivery system in accordance with the present invention and the schematic diagram illustrated in Figure 1. Current pulsations 30 are delivered to reservoir 12, and pulsating amounts of drug 32 are transported across skin 16 by oscillatory streaming to the systemic blood of the patient in response to the rhythmical variations of pulsations 30. Current pulsations 30 are shown as being delivered at periodic one hour intervals for purposes of exposition, but the intervals could be between a few minutes to a number of hours. Oscillatory amounts of drug delivered increase gradually in response to pulsations 30, then over the next hour gradually decrease in accordance with the depletion of the drug in skin 16. A small amount of the drug is still retained in skin 16 when the next current pulsation 30 is triggered by oscillator 28 and skin 16 again responds in an oscillatory process by transporting the drug to the systemic blood of the patient. In this manner a predictable supply of the drug is delivered to the patient in a predetermined manner. Delivery of drugs A, B, and C having long, medium, and short half-lives 32A, 32B, and 32C, respectively, are illustrated. The time in the ordinate axis is also a function of the transit time for the particular drug. A long half-life drug A is delivered at a substantially steady state delivery mode that is highly advantageous over a delivery by a steady state current in that the total amount of current delivered is reduced with the result that electrochemical changes by the current of drug A in the drug reservoir is reduced. A medium half-life drug B is illustrated with a substantial pulsating delivery to the systemic blood. A short half-life drug C, such as LHRH, has defined pulsations 32C. If, for example, electrical pulsations 30 were applied so as to cause drug pulsations 32C to last for 6 minutes every hour, this drug system would ensure a natural supply of LHRH over an extended period of time with the result that the production of testosterone in males or or induction of ovulation in females would be produced. If the system were designed to deliver electrical pulsations 30, for example, two or more times an hour, the gonadotrophic secretion would be extinguished in both males and females. Such a system is useful in birth control and in treatment of cancers. The start and finish of each drug delivery pulsation

slightly lags the start and finish of each electrical pulsation.

In another embodiment of the invention, an electrophoretic drug delivery system in accordance with the schematic diagram shown in schematic in Figure 1 is illustrated in a model graph in Figure 3. Battery 22 ordinarily delivers a positive current 38 and in response an amount of drug 40 is delivered to the systemic blood of the patient. Oscillator 36 causes current value increases, or pulsations, 42, which are greater than current 38, to be delivered to skin 16, which in response transports the liquid with the drug in undamped oscillatory streaming across skin 16 to the systemic blood of the patient shown as oscillatory amounts of drug delivered 44. Current pulsations 42 are shown as being delivered at periodic one hour intervals for purposes of exposition, but the periodic intervals could be spaced between a few minutes to a number of hours. Amounts of drug delivered 44 increase gradually in response to pulsations 42, then over the next hour gradually decreases towards amount of drug delivered 40 in accordance with the depletion of liquid in skin 16. When the next current pulsation 42 is triggered by oscillator 36, skin 16 again responds in the oscillatory process by again transporting the drug to the systemic blood of the patient. In this manner alternate amounts of drug 40 and pulsating amounts of drug 44 are delivered to the systemic blood of the patient. Although only one drug is shown, variations of the drug delivered in accordance with drugs having long, medium, and short half-lives as shown in Figure 2 can also be used in the system of Figure 3.

The system shown in Figure 3 is advantageous for the delivery of insulin to a patient. The body requirements of insulin are that it must be continuously delivered to a patient, but extra quantities are required at certain times such as after meals. Oscillator 36 can be set to or triggered to follow meals of the patient.

Another type of drug that can be used with the drug delivery system shown in Figure 3 is one of the anti-cancer drugs, which are most effective in the night hours when such a drug is less toxic to the patient as it can be during daytime hours.

Another embodiment of the present invention is a drug delivery system shown in an electrical schematic diagram in Figure 4. A pair of batteries 22A and 22B in parallel in the circuit are oriented in opposed polar relationship with the circuit. A switch 48 connected to both batteries 22A and 22B can be operated to alternately bring either battery 22A or 22B into the circuit with the result that the direction of current flow in the circuit is alternatively reversed. A timer, or oscillator, 50 causes switch 48 to be operated at periodic intervals. Battery 22B generates a negative current at drug reservoir 12.

Negative current at drug reservoir 12 draws liquid with the drug present in skin membrane 16 into solution 24 in drug reservoir 12. This action inhibits residues of the drug in skin membrane 16 from passing into the systemic blood of the patient. At selected periodic intervals the timer activates oscillator 50 to operate switch 48 so as to bring battery 22A into the circuit and isolate battery 22B from the circuit. The positive current that is generated by battery 22A is a much greater current than the low negative current generated by battery 22B and in addition is applied for short pulsation periods rather than the long pulsation periods of the negative current. In response to the rhythmical applications of the positive current, the liquid in solution 24 along with the drug is transported from reservoir 12 into skin 16 to the systemic blood of the patient in oscillatory processes. At the end of each pulsation period, oscillator 50 operates switch 48 to deactivate battery 22A and activate battery 22B so as to create once again an alternate negative current at reservoir 12.

Figure 5 illustrates an alternate schematic diagram embodiment to the system shown in Figure 4. A single battery 22C is connected to a solid state, double-pole, double-throw switch 52 that can be activated by an oscillator 54 to reverse the direction of flow of current from positive to negative and the reverse. Oscillator 54 causes a positive current to flow to drug reservoir 12 when switch 52 is activated in one current flow direction, and causes a negative current to flow to drug reservoir 12 when switch 52 is activated in the opposite current flow direction.

Figure 6 shows a model graph that illustrates a drug delivery system according to Figures 4 and 5. A negative current 56 is generated either by battery 22B or by battery 22C so that a very low amount of drug 58 at a level that is substantially zero is delivered to the systemic blood of the patient during the application of negative current 56. The reason for this phenomenon is that it is difficult to totally prevent drug migration into the body of the patient once the drug is in skin membrane 16. Positive current pulsations 60 are generated either by battery 22A or by battery 22B so as to trigger rhythmical variations of the potential and resistance of skin membrane 16 in synchronization with current pulsations 60 so as to cause oscillatory electro-osmotic streaming of the liquid with the drug across skin membrane 16 to the systemic blood of the patient in amounts of drug delivered 62 in response to the mentioned rhythmical variations. Drugs having long, medium, and short half-lives analogous to drugs A, B, and C shown in Figure 2 can be used in the system illustrated in Figure 6.

An inverted image of the electrical current of

the graph illustrated in Figure 6 is possible as indicated by the reversed positive and negative signs in parenthesis. The graph of Figure 6 and the inverted image of the graph relate to drugs that migrate from different poles.

Figure 7 illustrates an integral excitable, or oscillatory, membrane 68 that includes an adhesive gel semipermeable membrane 26A connected with cover 25 surrounding drug solution 24. Integral oscillatory membrane 26A is in contact with skin 16 of a patient. An adhesive hydrogel interface 70 is positioned between integral oscillatory membrane 26A and skin 16. Skin 16 is a part of integral oscillatory membrane 68. When integral oscillatory membrane 68 is positioned in the schematic systems illustrated in Figures 1, 4, and 5, analogous results to the drug delivery systems shown in the model graphs of Figures 2, 6, and 7 can be obtained with integral oscillatory membrane 68 acting as a unified oscillatory membrane rather than skin 16 alone.

Figure 8 is a model graph illustrating a pulsating voltage 72 applied to the systems described in Figure 1. A net flow, or flux, of the drug solution is shown in movement across skin 16 or integral membrane 68. A positive flux 74 results when voltage 72 is increased and a negative flux 76 results when voltage 72 is decreased. The reason for this phenomenon is the coupling between three driving forces of the pulsating system, namely, gradients of drug concentration, membrane potential, and hydrostatic pressure within a charged membrane and in addition the presence of a time delay of the resistance change of the membrane.

Although the present invention has been described in some detail by way of illustration and example for purposes of clarity and understanding, it will, of course, be understood that various changes and modifications made in the form, details, and arrangements of the parts without departing from the scope of the invention as set forth in the following claims.

Claims

1. An electrophoretic/electro-osmotic transdermal drug delivery system for passing at least one therapeutic compound through the skin (16) membrane of a patient for delivery to the systemic blood, comprising, in combination, drug storage means (12) in juxtaposition with the skin (16) of the patient, said drug storage means (12) being for holding a liquid (24) containing a therapeutic compound, power means for generating an electrical current, electrical circuit means for connecting to said power means, said drug storage means (12), and the skin (16) membrane, said liquid (24) con-

taining the therapeutic compound being moved along by electrophoretic/electro-osmotic movement into the skin (16), and electrical pulsation means connected with said circuit means for applying periodic electrical variations to said drug storage means (12) so as to trigger rhythmical variations of the potential and resistance of the skin (16) membrane in synchronization with said electrical pulsation means in order to cause oscillatory electro-osmotic streaming of the liquid (24) with the therapeutic compound across the skin (16) membrane to the systemic blood of the patient in response to the rhythmical variations.

2. The system of claim 1, wherein said electrical pulsation means includes an oscillator (28, 50, 54) that periodically applies said electrical current to said circuit, said circuit being otherwise devoid of current.

3. The system of claim 1 or 2, wherein said electrical pulsation means includes an oscillator (28, 50, 54) that alternately applies a positive first current and a positive second current to said electrical circuit, said positive second current being much greater in value than said positive first current.

4. The system of one of the preceding claims, wherein said electrical pulsation means includes a timer that alternately applies a positive first current and a positive second current to said electrical circuit, said positive second current being much greater in value than said positive first current.

5. The system of one of the preceding claims, wherein said power means includes two batteries (22A, 22B) connected to said circuit; and said electrical pulsation means includes a switch (48) connected with said circuit capable either of connecting one battery of said two batteries (22A, 22B) with said circuit in one polar orientation and simultaneously disconnecting the other battery of said two batteries (22A, 22B) from said circuit or of connecting said other battery with said circuit in the other polar direction and simultaneously disconnecting said one battery from said circuit.

6. The system of one of the preceding claims, wherein said power means includes a battery (22C) connected to said circuit, and a solid state double-poled, double-throw switch (52) connected to said battery (22C), said double-throw switch (52) being capable of reversing the polarity of said battery (22C) relative said circuit so as to reverse the direction of flow of current in said circuit.

7. The system of one of the preceding claims, wherein said electrical pulsation means further includes an oscillator (28, 50, 54) that alternately applies an negative first current and a positive second current to said circuit.

8. The system of one of the preceding claims, wherein said electrical pulsation means further includes an oscillator (28, 50, 54) that alternately applies a positive first current and a negative second current to said circuit.

9. The system of one of the preceding claims, wherein the therapeutic compound is a natural compound of the body or an active analogue thereof.

10. The system of one of the preceding claims, wherein said periodic electrical variations are applied in a similar rhythm as the natural delivery rhythm of the body so that the natural delivery rhythm is simulated.

11. The system of one of the preceding claims, wherein said periodic electrical variations are applied at such a frequency that the natural delivery rhythms of the body are inhibited or extinguished.

12. The system of one of the preceding claims, wherein the therapeutic compound is foreign to the body and said periodic electrical variations are applied in accordance with the body requirements of the particular therapeutic compound.

13. An electrophoretic/electro-osmotic transdermal drug delivery system for passing at least one therapeutic compound through the skin (16) of a patient for delivery to the systemic blood, comprising, in combination, drug storage means (12) in juxtaposition with the skin (16) of the patient, said drug storage means (12) being for holding a liquid (24) containing the therapeutic compound, semi-permeable means (26, 26A) in electrophoretic/electro-osmotic contact with the skin (16) of the patient and said drug storage means (12) for providing an electrophoretic/electro-osmotic flow passage for said liquid (24) with the therapeutic compound between said drug storage means (12) and the skin (16) of the patient, power means for generating an electrical current, excitable cell membrane means (68) including the skin (16) of the patient and said semi-permeable membrane means (26, 26A) for providing an integral oscillatory cell membrane for the passage of said liquid (24) with the therapeutic compound between said reservoir (12) and the systemic blood of the patient, electrical circuit means for connecting to said power means, said drug storage means (12), and the skin (16) membrane, said liquid (24) containing the therapeutic compound being moved along with said current by electrophoretic/electro-osmotic movement into the skin, and electrical pulsation means connected with said circuit means for applying periodic electrical variations to said drug storage means (12) so as to trigger rhythmical variations of the potential and resistance of the skin (16) membrane in synchronization with said electrical pulsation means in order to cause oscillatory electro-osmotic streaming of the liquid (24) with the

therapeutic compound across the skin (16) membrane to the systemic blood of the patient in response to the rhythmical variations.

14. An electrophoretic/electro osmotic transdermal drug delivery system for passing at least one therapeutic compound through the skin (16) membrane of a patient for delivery to the systemic blood, comprising, in combination, drug storage means (12) in juxtaposition, with the skin (16) of the patient, said drug storage means (12) being for holding a liquid (24) containing a therapeutic compound, said therapeutic compound being capable of inducing ovulation in a female or being capable of causing ovulation in a female to cease, power means for generating an electrical current, electrical circuit means for connecting to said power means, said drug storage means (12), and the skin (16) membrane, said liquid (24) containing the therapeutic compound being moved along by electrophoretic/electro-osmotic movement into the skin, and electrical pulsation means connected with said circuit means for applying periodic electrical variations to said drug storage means (12) so as to trigger rhythmical variations of the potential and resistance of the skin (16) membrane in synchronization with said electrical pulsation means in order to cause oscillatory electro-osmotic streaming of the liquid (24) with the therapeutic compound across the skin (16) membrane to the systemic blood of the patient in response to the rhythmical variations.

15. The system of one of the preceding claims, wherein said periodic electrical variations are applied in a similar rhythm as the natural delivery rhythm of the body so that ovulation is induced in said female.

16. The system of one of the claims 1 to 14, wherein said periodic electrical variations are applied in a steady state mode or at an increased frequency from the natural frequency so that ovulation ceases in said female.

17. An electrophoretic/electro-osmotic transdermal drug delivery system for passing at least one therapeutic compound through the skin (16) membrane of a patient for delivery to the systemic blood, comprising, in combination, drug storage means (12) in juxtaposition with the skin (16) of the patient, said drug storage means (12) being for holding a liquid (24) containing a therapeutic compound, said therapeutic compound being capable of controlling the production of testosterone in a male, power means for generating an electrical current, electrical circuit means for connecting to said power means, said drug storage means, and the skin (16) membrane, said liquid (24) containing the therapeutic compound being moved along by electrophoretic/electro-osmotic movement into the skin (16), and electrical pulsation means connected

with said circuit means for applying periodic electrical variations to said drug storage means (12) so as to trigger rhythmical variations of the potential and resistance of the skin (16) membrane in synchronization with said electrical pulsation means in order to cause oscillatory electro-osmotic streaming of the liquid (24) with the therapeutic compound across the skin (16) membrane to the systemic blood of the patient in response to the rhythmical variations.

18. The system of claim 17, wherein said periodic electrical variations are applied in a similar rhythm as the natural delivery rhythm of the body so that the production of testosterone in said male is ensured.

19. The system of claim 17, wherein said periodic electrical variations are applied in a steady state mode or at an increased frequency from the natural frequency so that production of testosterone in said male ceases.

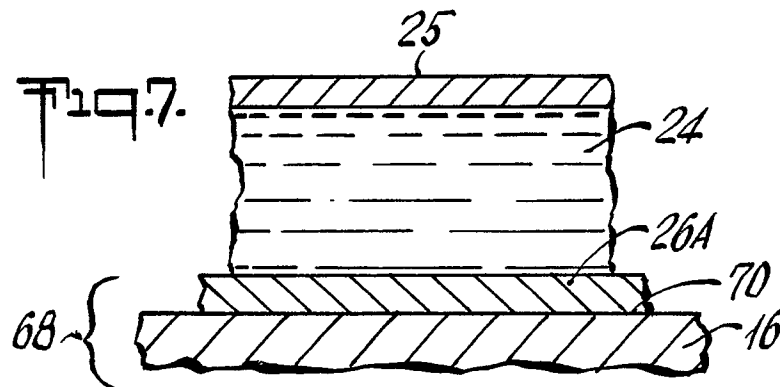
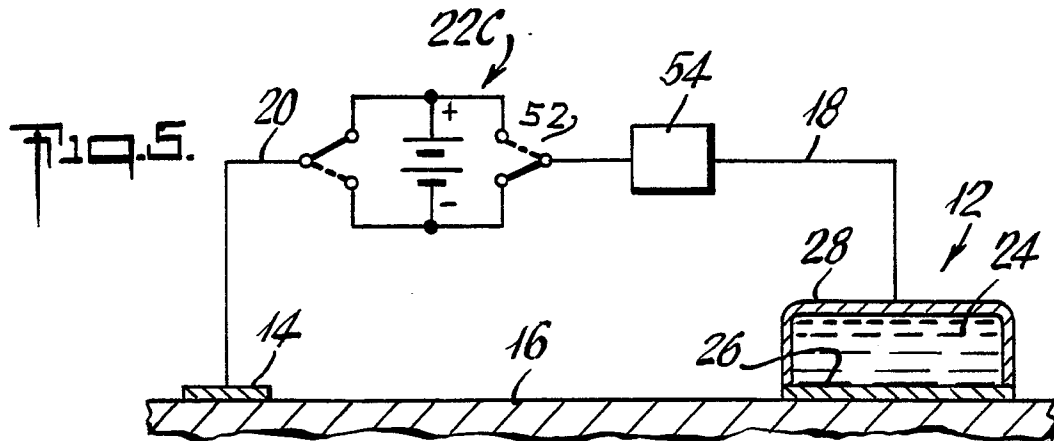
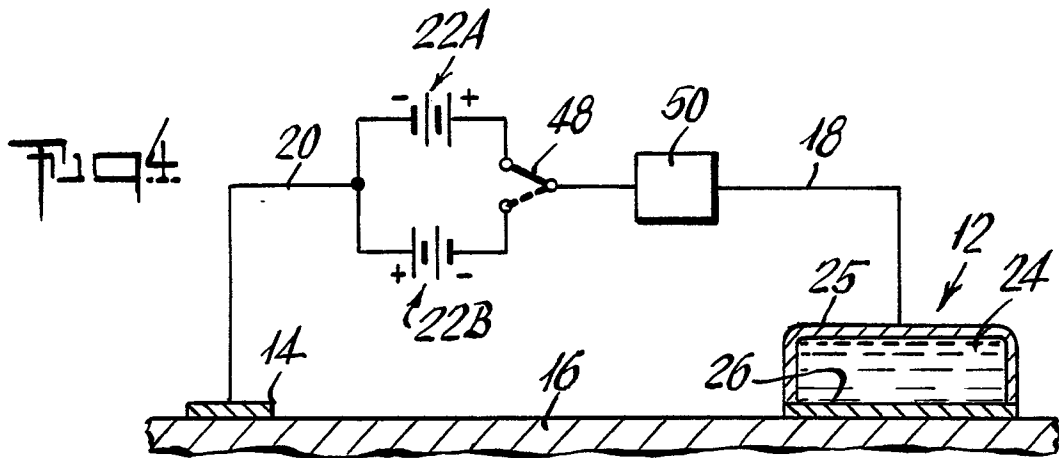
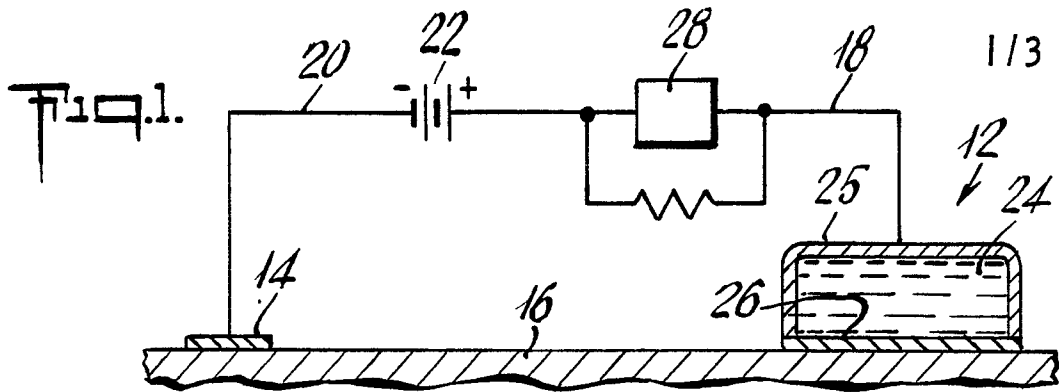

Fig. 2.

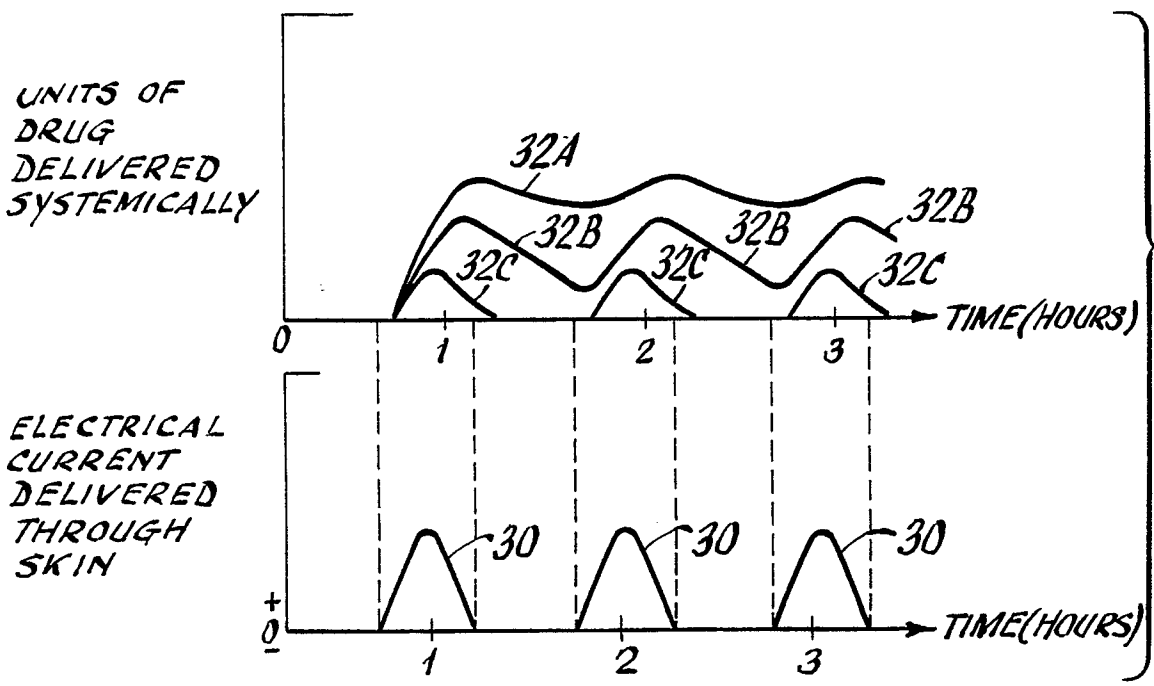

Fig. 3.

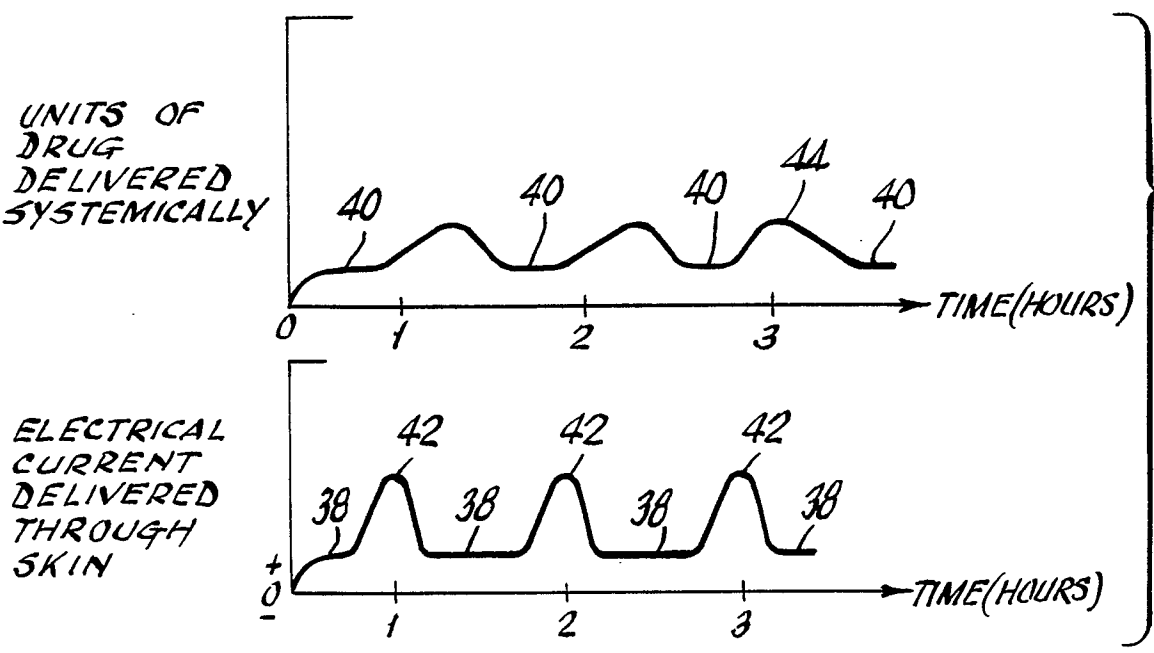
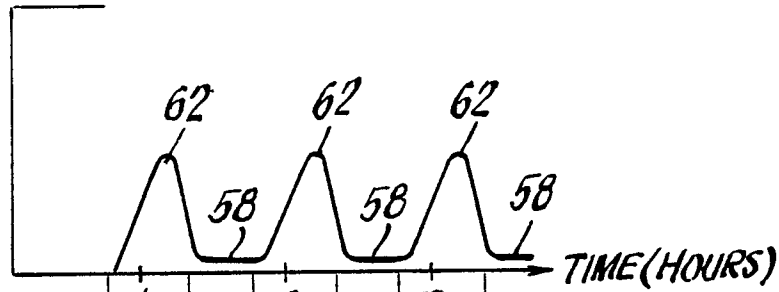

Fig. 6.

UNITS OF DRUG DELIVERED SYSTEMICALLY



ELECTRICAL CURRENT DELIVERED THROUGH SKIN (-) +

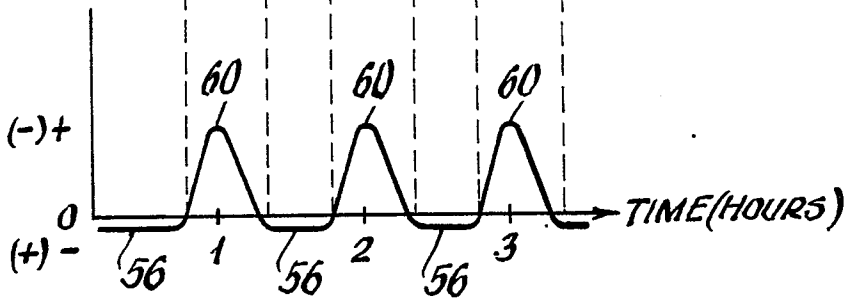
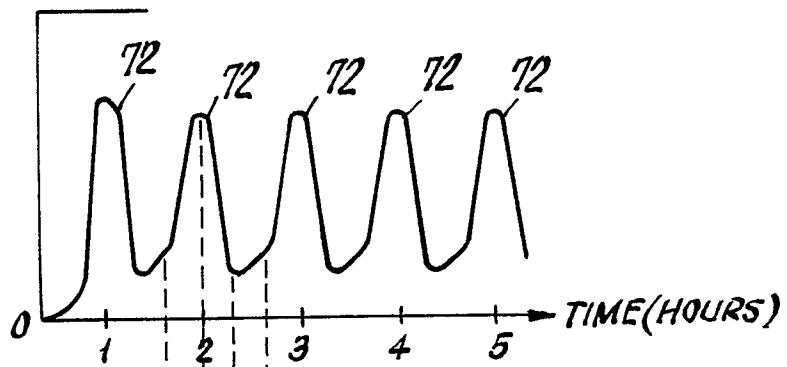
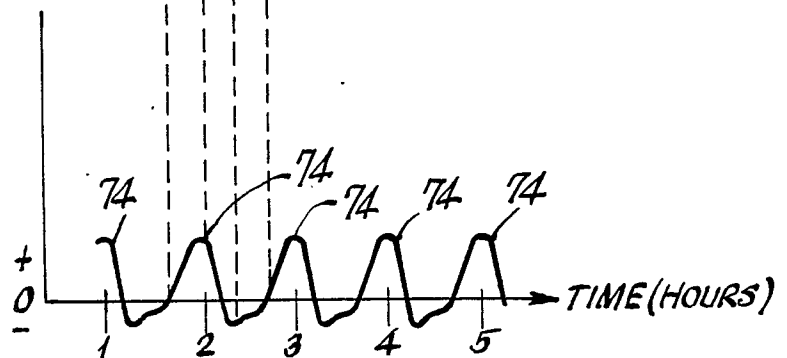

Fig. 8.

VOLTAGE APPLIED TO SYSTEM



NET FLOW (FLUX) OF DRUG SOLUTION ACROSS SKIN





DOCUMENTS CONSIDERED TO BE RELEVANT			EP 88108314.1
Category	Citation of document with indication, where appropriate, of relevant passages	Relevant to claim	CLASSIFICATION OF THE APPLICATION (Int. Cl. 4)
X	<p><u>EP - A1 - 0 138 347</u> (KANUSHIKI KAI SYA)</p> <p>* Abstract; page 4, lines 5-16; page 6, lines 10-26, 32-36; page 18, line 33 - page 19, line 29; page 30, line 30 - page 31, line 9; fig. 2a-6b, 10a-10d, 16-21 *</p> <p>--</p>	1-19	A 61 N 1/30
X	<p><u>GB - A - 2 177 928</u> (KEN HAYASHIBARA)</p> <p>* Abstract; claims 1, 3, 4,; fig. 4-6 *</p> <p>--</p>	1-4, 12	
A	<p><u>US - A - 4 639 244</u> (RIZK)</p> <p>* Column 1, line 57 - column 2, line 11; column 3, lines 12-18, 28-33, 50-60 *</p> <p>--</p>	1, 13, 14, 17	
A	<p><u>EP - A1 - 0 060 452</u> (MEDTRONIC)</p> <p>* Abstract; page 6, line 28 - page 7, line 13; fig. 5-8 *</p> <p>--</p>	1, 6	
A	<p><u>EP - A1 - 0 011 813</u> (MOTION CONTROL)</p> <p>* Abstract; claim 1 *</p> <p>--</p>	1, 13	
A	<p><u>US - A - 4 292 965</u> (NASH)</p> <p>* Column 1, lines 52-60; claims 1-5 *</p> <p>--</p>	1, 14	
The present search report has been drawn up for all claims			
Place of search VIENNA		Date of completion of the search 30-08-1988	Examiner NEGWER
<p>CATEGORY OF CITED DOCUMENTS</p> <p>X : particularly relevant if taken alone Y : particularly relevant if combined with another document of the same category A : technological background O : non-written disclosure P : intermediate document</p> <p>T : theory or principle underlying the invention E : earlier patent document, but published on, or after the filing date D : document cited in the application L : document cited for other reasons</p> <p>& : member of the same patent family, corresponding document</p>			



DOCUMENTS CONSIDERED TO BE RELEVANT			EP 88108314.1
Category	Citation of document with indication, where appropriate, of relevant passages	Relevant to claim	CLASSIFICATION OF THE APPLICATION (Int. Cl.4)
A	<p><u>US - A - 4 218 255 (BAJPAI)</u></p> <p>* Abstract; column 1, lines 24-28 *</p> <p>-----</p>	1,14,17	
			TECHNICAL FIELDS SEARCHED (Int. Cl.4)
The present search report has been drawn up for all claims			
Place of search VIENNA		Date of completion of the search 30-08-1988	Examiner NEGWER
<p>CATEGORY OF CITED DOCUMENTS</p> <p>X : particularly relevant if taken alone</p> <p>Y : particularly relevant if combined with another document of the same category</p> <p>A : technological background</p> <p>O : non-written disclosure</p> <p>P : intermediate document</p>		<p>T : theory or principle underlying the invention</p> <p>E : earlier patent document, but published on, or after the filing date</p> <p>D : document cited in the application</p> <p>L : document cited for other reasons</p> <p>& : member of the same patent family, corresponding document</p>	