

(19) World Intellectual Property Organization  
International Bureau



(43) International Publication Date  
17 August 2006 (17.08.2006)

PCT

(10) International Publication Number  
**WO 2006/085884 A1**

(51) International Patent Classification:  
**B26B 21/44** (2006.01)

(74) Agent: **MICHAUD, Richard**; Michaud-Duffy Group  
LLP, 306 Industrial Park Road, Suite 206, Middletown,  
Connecticut 06457 (US).

(21) International Application Number:  
PCT/US2005/004874

(81) Designated States (unless otherwise indicated, for every  
kind of national protection available): AE, AG, AL, AM,  
AT, AU, AZ, BA, BB, BG, BR, BW, BY, BZ, CA, CH, CN,  
CO, CR, CU, CZ, DE, DK, DM, DZ, EC, EE, EG, ES, FI,  
GB, GD, GE, GH, GM, HR, HU, ID, IL, IN, IS, JP, KE,  
KG, KP, KR, KZ, LC, LK, LR, LS, LT, LU, LV, MA, MD,  
MG, MK, MN, MW, MX, MZ, NA, NI, NO, NZ, OM, PG,  
PH, PL, PT, RO, RU, SC, SD, SE, SG, SK, SL, SM, SY,  
TJ, TM, TN, TR, TT, TZ, UA, UG, US, UZ, VC, VN, YU,  
ZA, ZM, ZW.

(22) International Filing Date:  
10 February 2005 (10.02.2005)

(25) Filing Language: English

(26) Publication Language: English

(71) Applicant: **EVEREADY BATTERY COMPANY, INC.**  
[US/US]; 533 Maryville University Drive, St. Louis, Mis-  
souri 63141 (US).

(72) Inventors: **FRANZINI, John**; 15 Baxter Road, Hollis,  
New Hampshire 03049 (US). **ROCHE, David**; 27 Fair-  
mount Street, Nashua, New Hampshire 03064 (US). **PEN-  
NELLA, Andrew**; 180 Blackwood Lane, Stamford, Con-  
necticut 06901 (US). **RAYMOND, Kenneth A.**; 356 Bea-  
con Road, Bethany, Connecticut 06524 (US).

(84) Designated States (unless otherwise indicated, for every  
kind of regional protection available): ARIPO (BW, GH,  
GM, KE, LS, MW, MZ, NA, SD, SL, SZ, TZ, UG, ZM,  
ZW), Eurasian (AM, AZ, BY, KG, KZ, MD, RU, TJ, TM),  
European (AT, BE, BG, CH, CY, CZ, DE, DK, EE, ES, FI,  
FR, GB, GR, HU, IE, IS, IT, LT, LU, MC, NL, PL, PT, RO,

[Continued on next page]

(54) Title: SHAVING APPARATUS

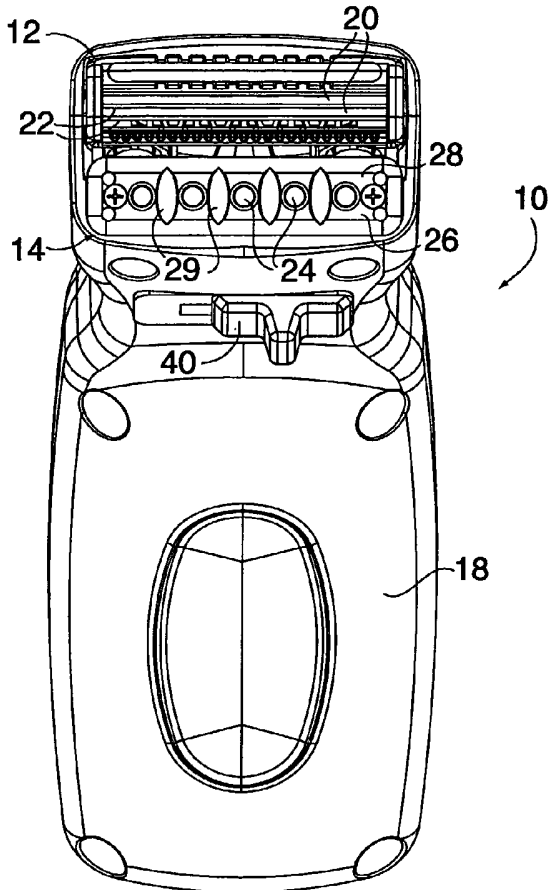

(57) Abstract: A shaving apparatus (10) is provided that includes a razor cartridge (12), a shaving aid dispenser (14), and a reservoir (16) operable to contain a non-solid shaving aid material. The shaving aid dispenser includes one or more valves (24) disposed within a contact panel (26). The contact panel is disposed adjacent the cutting edges of the one or more razor blades. Each of the valves is selectively operable between an open position and a closed position. The valves are operated by the normal force of the contact surface applied to the surface to be shaved. The reservoir is in fluid communication with the selectively operable valves.

WO 2006/085884 A1



---

SE, SI, SK, TR), OAPI (BF, BJ, CF, CG, CI, CM, GA, GN, — *with amended claims*  
GQ, GW, ML, MR, NE, SN, TD, TG).

**Published:**

— *with international search report*

*For two-letter codes and other abbreviations, refer to the "Guidance Notes on Codes and Abbreviations" appearing at the beginning of each regular issue of the PCT Gazette.*

## **SHAVING APPARATUS**

### **Background of the Invention**

#### **Technical Field**

5           The present invention relates to shaving apparatus in general, and to shaving apparatus having a mechanism for providing a flowable shaving aid material in particular.

#### **Background Information**

10           Numerous attempts have been made to combine a razor assembly with a mechanism for dispensing shaving aid material. Typically, the shaving apparatus will include a reservoir containing a shaving aid material and one or more passages connecting the reservoir to a point of discharge. The shaving aid material is picked up by the user at the point of discharge. The shaving aid material is typically forced from the reservoir by pressurized gas, or by mechanical arrangement that decreases the volume of the reservoir.

15           In some instances, a valve mechanism is disposed within the shaving apparatus proximate the reservoir to prevent discharge of shaving aid material from the reservoir when the razor assembly is not in use. To be commercially successful, the valve mechanism of the shaving apparatus should be easy to operate. It should also be easily manufactured at a low cost. It should also be adaptable for use with a variety of different shaving aid  
20 materials.

#### **Disclosure of the Invention**

          According to the present invention, a shaving apparatus is provided that includes a razor cartridge, a shaving aid dispenser, and a reservoir operable to contain a non-solid  
25 shaving aid material. The razor cartridge includes one or more razor blades, each having a cutting edge. The shaving aid dispenser includes one or more valves disposed within a contact panel. The contact panel is disposed adjacent the cutting edges of the one or more razor blades. Each of the valves is selectively operable between an open position and a closed position. The valves are operated by the normal force of the contact surface applied  
30 to the surface to be shaved. The reservoir is in fluid communication with the selectively operable valves.

          According to an aspect of the present invention, a shaving aid material dispenser is provided. The shaving aid dispenser includes one or more valves disposed within a contact

panel, and a reservoir. Each of the valves is selectively operable between an open position and a closed position. The valves are operated by the normal force of the contact surface applied to the surface to be shaved. The reservoir is in fluid communication with the selectively operable valves.

5 An advantage of the present invention is that a shaving aid material dispenser is provided that actuates automatically during the shaving process. The one or more valves operate from a closed position to an open position when the user applies the shaving apparatus to the surface to be shaved. Hence, the shaving aid material exits, and is therefore applied, only during the shaving process. Once the contact panel is moved out of contact  
10 with the surface, the valves are closed, thereby stopping the flow of shaving aid material.

Another advantage of the present invention is that in addition to selectively regulating the flow of shaving aid material, the one or more valves also meter and distribute the flow of shaving aid material.

These and other objects, features, and advantages of the present invention will  
15 become apparent in light of the detailed description of the present invention.

#### **Brief Description of the Drawings**

FIG. 1 is a diagrammatic isometric view of an embodiment of the present invention shaving apparatus.

20 FIG. 2 is an enlarged view of the embodiment shown in FIG.1.

FIG. 3 is a partially sectioned diagrammatic view of a shaving apparatus.

FIG. 4 is a diagrammatic view of a portion of the present invention shaving aid dispenser.

25 FIG. 5 is a sectional diagrammatic view of a portion of the present invention shaving aid dispenser, illustrating a valve embodiment.

FIG. 6 is a sectional diagrammatic view of a portion of the present invention shaving aid dispenser, illustrating another valve embodiment.

FIG. 7 shows the shaving aid dispenser of FIG. 5 with the valve embodiment applied against a surface to be shaved and the valve in an open position.

30 FIG. 8 is a sectional diagrammatic view of a portion of the present invention shaving aid dispenser, illustrating a valve embodiment.

FIG. 9 is a sectional diagrammatic view of a portion of the present invention shaving aid dispenser, illustrating a valve embodiment.

FIG.9A is a sectional diagrammatic view of a portion of the present invention shaving dispenser, illustrating the valve embodiment shown in FIG.9 in an open position.

### **Detailed Description of the Invention**

5 Referring now to FIGS. 1-9, the shaving apparatus 10 includes a razor cartridge 12, a shaving aid dispenser 14, a reservoir 16 (see FIG.3), and a handle 18.

The razor cartridge 12 includes one or more razor blades 20 attached to a frame. Each razor blade has a cutting edge 22. The razor cartridge 12 can be fixedly or pivotally attached to the handle 18. A variety of different razor cartridges can be used with the present shaving apparatus 10, including those that are intended to be disposable. The present apparatus is not, therefore, limited to any particular type of razor cartridge 12.

10 The shaving aid dispenser 14 includes one or more selectively operable valves 24. The valves 24 may be disposed within, or may partially or completely form, a contact panel 26 disposed adjacent the razor cartridge 12. The contact panel 26, which includes a contact surface 28, may be continuous around the razor cartridge 12. The contact surface 28 may be planar or may include protruberances 29. In some embodiments, the contact panel 26 may be one or more sections that are disposed adjacent the razor cartridge 12; e.g., the contact panel 26 shown in FIGS. 1 and 2 disposed forward of the razor cartridge 12. Other embodiments of the contact panel 26 may be disposed aft of the razor cartridge 12, or on one or both sides of the razor cartridge 12, or some combination thereof.

15 Referring to FIGS. 4-9, each of the valves 24 is selectively operable between an open position and a closed position. In the open position (e.g., see FIG.7), a passage 30 is created for shaving aid material to flow through the valve 24 under normal conditions. In the closed position (e.g., see FIGS. 5 and 6), the passage 30 is eliminated and consequently no appreciable amount of shaving aid material flows through the valve 24 under normal conditions. In preferred embodiments, each of the valves 24 include a male portion 32 and a female portion 34 that mates with one another to form a seal when the valve 24 is in a closed position. In the embodiments shown in FIGS. 4-8, the female portion 34 of each valve 24 is disposed within the contact panel 26. In the embodiment shown in FIG.9, the male portion 32 of each valve 24 is formed within the contact panel 26, and a member 35 disposed below the contact panel 26 forms the female portion 34, as will be described below. In the embodiment shown in FIGS. 5 and 7, the male and female portions 32, 34 have mating conical sections that seal when the male portion 32 is inserted within and in

contact within the female portion 34. In the embodiment shown in FIGS. 6 and 8, the mating male and female portions 32, 34 of the valves 24 are at least partially spherical. A variety of mating shapes can be used for the sealing surfaces. At least one of the male or female portions 32, 34 is positioned to contact the surface to be shaved.

5           The valves 24 can operate independently of one another, or can operate in concert; e.g., in a manner wherein operating one valve 24 causes one or more other valves 24 to operate at least partially. In the embodiments shown in FIGS. 5-7, each male portion 32 is attached to a support member 36. Pushing on a male portion 32 that is attached to a relatively stiff support member 36 will cause one or more of the adjacent male portions 32  
10 to depress at least partially, thereby opening the adjacent valves 24. Alternatively, pushing on a male portion 32 that is attached to a relatively flexible support member 36 will not cause adjacent male portions 32 to depress at least partially, and the adjacent valves 24 will remain closed. The embodiment shown in FIG.8 illustrates an embodiment utilizing independent valves 24 with independent biasing elements 38. In the embodiments shown in  
15 FIGS. 4-8, each male portion 32 extends up through a female portion 34 to form a valve 24. In the embodiment shown in FIGS. 9 and 9A, the male portion 32 is attached to the contact panel 26 and the female portion 34 is formed when the member 35 disposed contiguous with the contact panel 26 is deflected to form an opening (open position shown in FIG.9A). The present invention is not limited to the aforesaid illustrative embodiments.

20           The one or more valves 24 are preferably biased in the closed position. A support member 36 (e.g., as shown in FIGS. 5-7) comprising an elastomeric material is an example of a means for biasing the portions of that valve 24 in the closed position. The elasticity of the support member 36 is such that a desirable amount of force applied against the exposed part of the male portion 32 overcomes the biasing force of the elastic support member 36,  
25 thereby permitting the valve 24 to actuate from a closed position to an open position. Biasing means other than the above-described elastomeric embodiment may be used alternatively; e.g., the independent biasing elements 38. As a further example, the member 35 disposed below the contact panel 26 in FIG.9 may be elastomeric.

30           The one or more valves 24 are preferably positioned in a pattern selected to provide a desirable distribution of shaving aid material. In the embodiment shown in FIG.2, for example, the valves 24 are uniformly disposed in a contact panel 26 disposed forward of the razor cartridge 12. The flow rate and distribution of the shaving aid material from the valves 24 can be adjusted to suit the application at hand by adjusting the number of valves

24 within a pattern and the flow through the individual valves 24. Flow through individual valves 24 is selectively chosen to accommodate the physical properties (e.g., viscosity) of the shaving aid material for a predetermined set of application parameters (e.g., temperature, surface moisture, etc.). For those valve 24 embodiments that include mating male and female portions 32, 34, a variety of different flow rate profiles can be produced by selectively matching the geometries of the mating portions 32, 34. For example, conical shaped mating surfaces 32, 34 may produce a linear increase in flow rate through the valve 24 as the mating portions separate from one another. Other mating surface geometries may produce a stepped, or an exponential, increase in flow through the valve 24 as the mating surfaces separate from one another. The present invention valves 24 are not, therefore, limited to any particular mating geometry configuration.

The reservoir 16 for containing the non-solid shaving aid material is in fluid communication with the selectively operable valves 24. The fluid communication between the reservoir 16 and the valves 24 permits non-solid shaving aid material within the reservoir 16 to pass from the reservoir 16 to the valves. The reservoir 16 is not limited to any particular configuration. In some embodiments, the reservoir 16 is not intended to be separated from the handle 18. In these embodiments, the reservoir 16 may be a refillable. In other embodiments, the reservoir 16 may be a replaceable item independent of the handle 18, or disposable as part of a replaceable handle 18.

In the embodiment shown in FIGS. 1-3, the shaving apparatus 10 further includes a flow valve 40 disposed between the reservoir 16 and the one or more valves 24. The flow valve 40 is a two-position valve, on and off, that is operable to prevent fluid flow between the reservoir 16 and the one or more valves 24.

In the operation of the invention, the shaving apparatus 10 includes a volume of shaving aid material disposed within the reservoir 16 under pressure. A variety of different mechanisms can be used to create the pressure necessary to force the material out through the valves 24, and the present invention is not limited to any particular mechanism. The user applies the shaving apparatus 10 to the surface 42 (see FIG.7) to be shaved with a typical amount of normal force, and strokes the shaving apparatus 10 across the surface 42. When the shaving apparatus 10 is applied to the surface 42 to be shaved during normal operation, at least a part of the contact panel 26 and at least one of the valves 24 is placed in contact with the surface 42. When the valve(s) 24 is placed in contact with the surface 42, the normal force applied to the contact panel 26 and valve 24 changes the valve 24 from a

closed position to an open position; i.e., at least one of the mating male and female portions 32, 34 is moved relative to the other to create a passage 30 through the valve. In the embodiment shown in FIG.9, the normal force applied to the contact panel 26 and the male portions 32, causes one or more of the male portions 32 to move the member 35 away from the contact panel 26, thereby creating a passage 30 therebetween. In the open position, pressurized shaving aid material from the reservoir 16 flows through the valve passage 30 and is applied to the surface being shaved. Once the normal force is removed, the valve 24 returns to the closed position (i.e., the passage 30 is closed) and the flow of shaving aid material therethrough is ceased.

10           The present invention shaving aid dispenser 14 has been described above as an element within a shaving apparatus 10 having a handle 18. According to an aspect of the present invention, the shaving aid dispenser 14 is a portion of a replaceable cartridge that can be selectively attached and removed from a shaving apparatus. When all the usable shaving aid material has been withdrawn from the cartridge, the empty cartridge can be removed from the shaving apparatus 10 and replaced with a new or refilled cartridge.

15           Although this invention has been shown and described with respect to the detailed embodiments thereof, it will be understood by those of skill in the art that various changes may be made and equivalents may be substituted for elements thereof without departing from the scope of the invention. For example, the embodiments of the present invention described above include one or more valves 24, each having a male portion 32 that moves relative to the female portion 34 to open the valve. In alternative embodiments, the female portion could move relative to the male portion 32 to open the valve.



What is claimed is:

1. A shaving apparatus, comprising:  
a razor cartridge having one or more blades, each having a cutting edge;  
a shaving aid dispenser having one or more valves disposed within a contact panel,  
which contact panel is disposed adjacent the cutting edges of the one or more razor blades,  
5 wherein each of the valves is selectively operable between an open position and a closed  
position; and  
a reservoir for containing a non-solid shaving aid material, wherein the reservoir is  
in fluid communication with the one or more valves.
2. The shaving apparatus of claim 1, wherein each of the one or more valves  
includes a male portion and a female portion that mate with one another.
3. The shaving apparatus of claim 2, wherein the male portion and female  
portion include substantially conical sealing surfaces that are shaped to mate with one  
another.
4. The shaving apparatus of claim 2, wherein the male portion and female  
portion include substantially spherical sealing surfaces that are shaped to mate with one  
another.
5. The shaving apparatus of claim 2, wherein the male portions of the one or  
more valves are independent of one another.
6. The shaving apparatus of claim 5, wherein the male portion of each valve is  
biased into contact with the female portion of that valve
7. The shaving apparatus of claim 2, further comprising a support member,  
wherein the male portions of the one or more valves are attached to the support member.
8. The shaving apparatus of claim 7, wherein the support member comprises an  
elastomeric material.

9. The shaving apparatus of claim 2, wherein more than one of the one or more valves operates in concert between the open position and the closed position.

10. The shaving apparatus of claim 2, wherein the one or more valves are biased in the closed position.

11. The shaving apparatus of claim 10, wherein the female portions of the one or more valves are disposed within the contact panel, and in the closed position, the male portions are received within the female portions and the male portions extend partly above the contact surface.

12. The shaving apparatus of claim 2, wherein the male portions are formed within the contact panel.

13. The shaving apparatus of claim 1, wherein the one or more valves are biased in the closed position.

14. A shaving apparatus, comprising:  
a razor cartridge having one or more blades, each having a cutting edge;  
a shaving aid dispenser having one or more valves disposed within a contact panel,  
wherein each of the valves is selectively operable from a closed position to an open position  
5 by applying a normal force to the contact panel that is sufficient to operate the razor  
cartridge, and  
a reservoir for containing a non-solid shaving aid material, wherein the reservoir is  
in fluid communication with the one or more valves.

15. The shaving apparatus of claim 14, wherein each of the one or more valves includes a male portion and a female portion that mate with one another.

16. The shaving apparatus of claim 15, wherein the male portion of each valve is biased into contact with the female portion of that valve.

17. The shaving apparatus of claim 16, further comprising a support member, wherein the male portions of the one or more valves are attached to the support member.

18. The shaving apparatus of claim 17, wherein the support member comprises an elastomeric material.

19. The shaving apparatus of claim 14, wherein more than one of the one or more valves operates in concert between the open position and the closed position.

20. The shaving apparatus of claim 14, wherein the one or more valves are biased in the closed position.

**AMENDED CLAIMS**

received by the International Bureau on 12 January 2006 (12.01.2006)

What is claimed is:

1. A shaving apparatus (10), wherein the shaving apparatus (10) includes:  
a razor cartridge (12) having one or more blades (20), each having a cutting edge (22);  
a shaving aid dispenser (14) characterized by one or more valves (24) disposed  
5 within a contact panel (26), which contact panel (26) is disposed adjacent the cutting edges (22) of the one or more razor blades (20), wherein each of the valves (24) is selectively operable between an open position and a closed position; and  
a reservoir (16) for containing a non-solid shaving aid material, wherein the reservoir (16) is in fluid communication with the one or more valves (24).
2. The shaving apparatus (10) of claim 1, wherein each of the one or more valves (24) includes a male portion (32) and a female portion (34) that mate with one another.
3. The shaving apparatus (10) of claim 2, wherein the male portion (32) and female portion (34) include substantially conical sealing surfaces that are shaped to mate with one another.
4. The shaving apparatus (10) of claim 2, wherein the male portion (32) and female portion (34) include substantially spherical sealing surfaces that are shaped to mate with one another.
5. The shaving apparatus (10) of claim 2, wherein the male portions (32) of the one or more valves (24) are independent of one another.
6. The shaving apparatus (10) of claim 5, wherein the male portion (32) of each valve (24) is biased into contact with the female portion (34) of that valve (24).

7. The shaving apparatus (10) of claim 2, further including a support member (36), wherein the male portions (32) of the one or more valves (24) are attached to the support member (36).
8. The shaving apparatus (10) of claim 7, wherein the support member (36) includes an elastomeric material.
9. The shaving apparatus (10) of claim 2, wherein more than one of the one or more valves (24) operates in concert between the open position and the closed position.
10. The shaving apparatus (10) of claim 2, wherein the one or more valves (24) are biased in the closed position.
11. The shaving apparatus (10) of claim 10, wherein the female portions (34) of the one or more valves (24) are disposed within the contact panel (26), and in the closed position, the male portions (32) are received within the female portions (34) and the male portions (32) extend partly above the contact surface (28).
12. The shaving apparatus (10) of claim 2, wherein the male portions (32) are formed within the contact panel (26).
13. The shaving apparatus (10) of claim 1, wherein the one or more valves (24) are biased in the closed position.

14. A shaving apparatus (10), wherein the shaving apparatus (10) includes:  
a razor cartridge (12) having one or more blades (20), each having a cutting  
edge (22);  
a shaving aid dispenser (14) having a contact panel (26) disposed adjacent the  
5 cutting edges (22) of the one or more razor blades, characterized by  
one or more valves (24) disposed within [[a]] the contact panel (26), wherein  
each of the valves (24) is selectively operable from a closed position to an open  
position by applying a normal force to the contact panel (26) that is sufficient to  
operate the razor cartridge (12), and  
10 a reservoir (16) for containing a non-solid shaving aid material, wherein the  
reservoir (16) is in fluid communication with the one or more valves (24).
15. The shaving apparatus (10) of claim 14, wherein each of the one or  
more valves (24) includes a male portion (32) and a female portion (34) that mate  
with one another.
16. The shaving apparatus (10) of claim 15, wherein the male portion (32)  
of each valve (24) is biased into contact with the female portion (34) of that valve  
(24).
17. The shaving apparatus (10) of claim 16, further including a support  
member (36), wherein the male portions (32) of the one or more valves (24) are  
attached to the support member (36).
18. The shaving apparatus (10) of claim 17, wherein the support member  
(36) includes an elastomeric material.

19. The shaving apparatus (10) of claim 14, wherein more than one of the one or more valves (24) operates in concert between the open position and the closed position.

20. The shaving apparatus (10) of claim 14, wherein the one or more valves (24) are biased in the closed position.

1/2

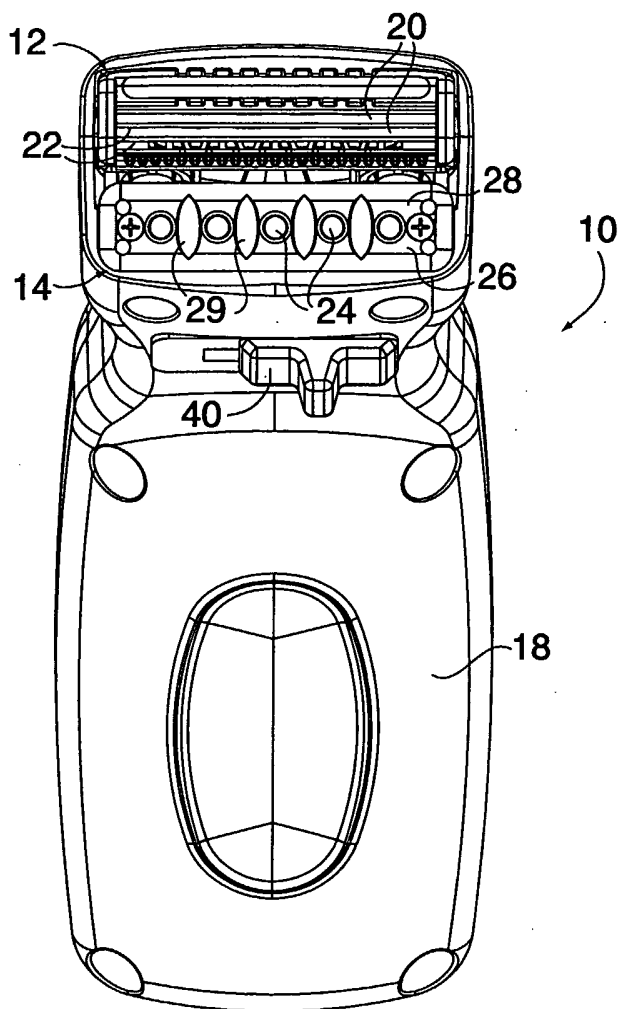

FIG. 1

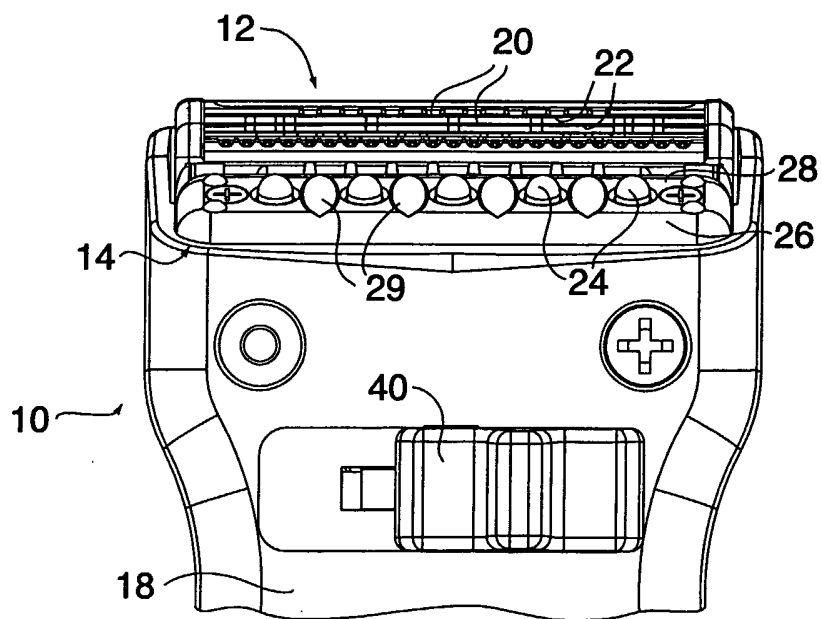

FIG. 2



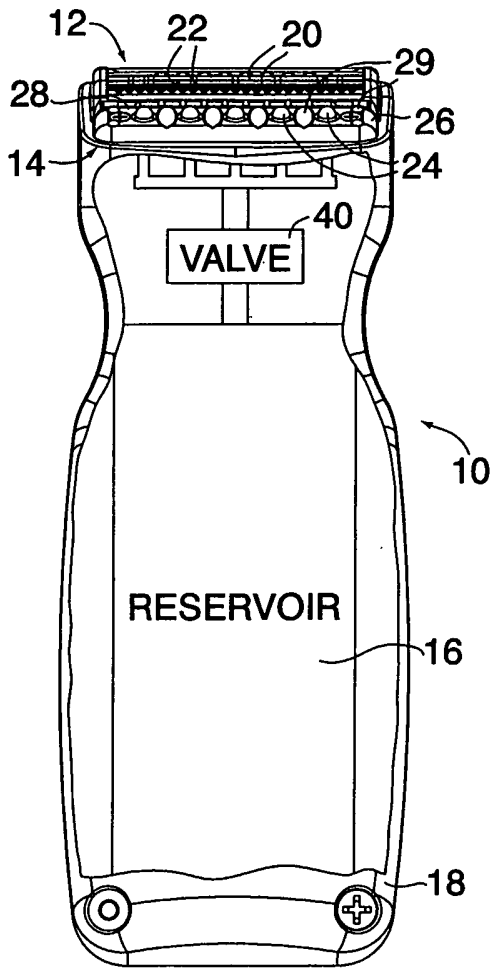

FIG. 3

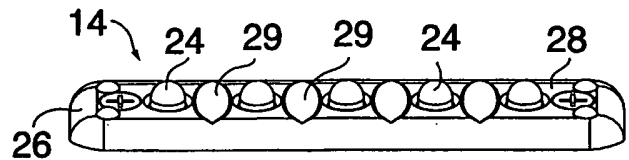

FIG. 4

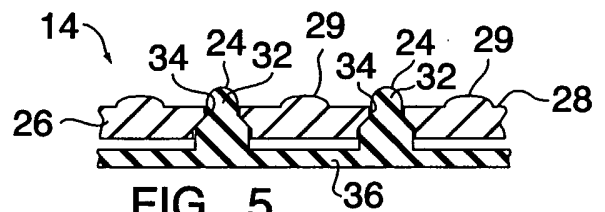

FIG. 5

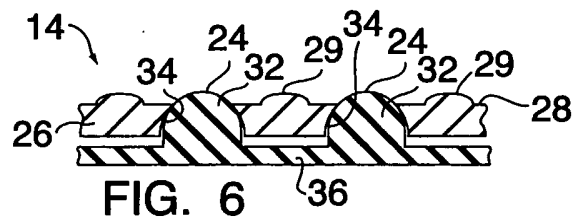

FIG. 6

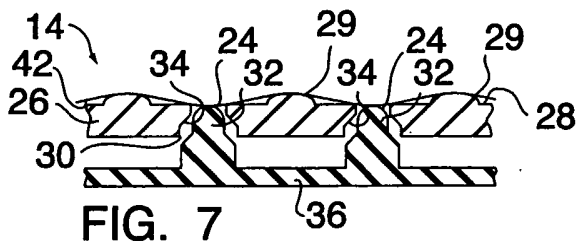

FIG. 7

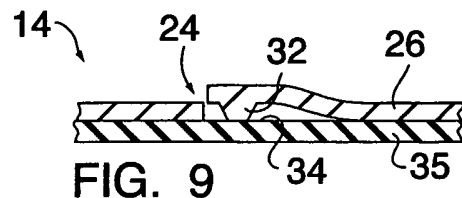

FIG. 9

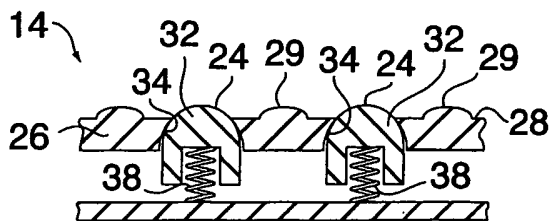

FIG. 8

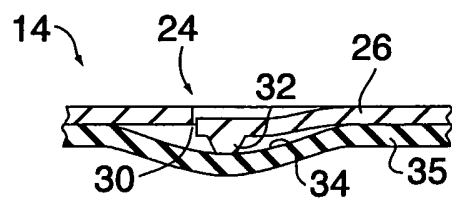

FIG. 9A

# INTERNATIONAL SEARCH REPORT

International Application No  
PCT/US2005/004874

<b>A. CLASSIFICATION OF SUBJECT MATTER</b> IPC 7 B26B21/44				
According to International Patent Classification (IPC) or to both national classification and IPC				
<b>B. FIELDS SEARCHED</b>				
Minimum documentation searched (classification system followed by classification symbols) IPC 7 B26B				
Documentation searched other than minimum documentation to the extent that such documents are included in the fields searched				
Electronic data base consulted during the international search (name of data base and, where practical, search terms used) EPO-Internal				
<b>C. DOCUMENTS CONSIDERED TO BE RELEVANT</b>				
Category °	Citation of document, with indication, where appropriate, of the relevant passages	Relevant to claim No.		
A	WO 2005/002809 A (EVEREADY BATTERY COMPANY, INC) 13 January 2005 (2005-01-13) page 5, line 10 - page 6, line 11; figures 1-5 -----	1, 14		
A	WO 2004/071260 A (EVEREADY BATTERY COMPANY INC) 26 August 2004 (2004-08-26) page 4, line 2 - page 5, line 16; figures 1,2 -----			
A	US 2002/023351 A1 (SIMMS GRAHAM JOHN) 28 February 2002 (2002-02-28) abstract; figures 1-5 -----			
A	US 5 337 478 A (COHEN ET AL) 16 August 1994 (1994-08-16) column 4, line 60 - column 6, line 10; figures 1-7 -----			
	-/--			
<input checked="" type="checkbox"/> Further documents are listed in the continuation of box C.				
<input checked="" type="checkbox"/> Patent family members are listed in annex.				
° Special categories of cited documents :				
<table style="width: 100%; border: none;"> <tr> <td style="width: 50%; border: none; vertical-align: top;">                     *A* document defining the general state of the art which is not considered to be of particular relevance                      *E* earlier document but published on or after the international filing date                      *L* document which may throw doubts on priority claim(s) or which is cited to establish the publication date of another citation or other special reason (as specified)                      *O* document referring to an oral disclosure, use, exhibition or other means                      *P* document published prior to the international filing date but later than the priority date claimed                 </td> <td style="width: 50%; border: none; vertical-align: top;">                     *T* later document published after the international filing date or priority date and not in conflict with the application but cited to understand the principle or theory underlying the invention                      *X* document of particular relevance; the claimed invention cannot be considered novel or cannot be considered to involve an inventive step when the document is taken alone                      *Y* document of particular relevance; the claimed invention cannot be considered to involve an inventive step when the document is combined with one or more other such documents, such combination being obvious to a person skilled in the art.                      *&amp;* document member of the same patent family                 </td> </tr> </table>			*A* document defining the general state of the art which is not considered to be of particular relevance *E* earlier document but published on or after the international filing date *L* document which may throw doubts on priority claim(s) or which is cited to establish the publication date of another citation or other special reason (as specified) *O* document referring to an oral disclosure, use, exhibition or other means *P* document published prior to the international filing date but later than the priority date claimed	*T* later document published after the international filing date or priority date and not in conflict with the application but cited to understand the principle or theory underlying the invention *X* document of particular relevance; the claimed invention cannot be considered novel or cannot be considered to involve an inventive step when the document is taken alone *Y* document of particular relevance; the claimed invention cannot be considered to involve an inventive step when the document is combined with one or more other such documents, such combination being obvious to a person skilled in the art. *&* document member of the same patent family
*A* document defining the general state of the art which is not considered to be of particular relevance *E* earlier document but published on or after the international filing date *L* document which may throw doubts on priority claim(s) or which is cited to establish the publication date of another citation or other special reason (as specified) *O* document referring to an oral disclosure, use, exhibition or other means *P* document published prior to the international filing date but later than the priority date claimed	*T* later document published after the international filing date or priority date and not in conflict with the application but cited to understand the principle or theory underlying the invention *X* document of particular relevance; the claimed invention cannot be considered novel or cannot be considered to involve an inventive step when the document is taken alone *Y* document of particular relevance; the claimed invention cannot be considered to involve an inventive step when the document is combined with one or more other such documents, such combination being obvious to a person skilled in the art. *&* document member of the same patent family			
Date of the actual completion of the international search  <p style="text-align: center;">7 November 2005</p>	Date of mailing of the international search report  <p style="text-align: center;">16/11/2005</p>			
Name and mailing address of the ISA European Patent Office, P.B. 5818 Patentlaan 2 NL - 2280 HV Rijswijk Tel. (+31-70) 340-2040, Tx. 31 651 epo nl, Fax: (+31-70) 340-3016	Authorized officer  <p style="text-align: center;">Maier, M</p>			

INTERNATIONAL SEARCH REPORT

International Application No  
PCT/US2005/004874

C.(Continuation) DOCUMENTS CONSIDERED TO BE RELEVANT		
Category °	Citation of document, with indication, where appropriate, of the relevant passages	Relevant to claim No.
A	US 4 238 882 A (HARRISON, JACK R SR) 16 December 1980 (1980-12-16) column 5, line 3 - column 6, line 30; figures 1-5	
A	----- GB 640 185 A (JAMES NOEL-DAVIES) 12 July 1950 (1950-07-12) page 5, line 28 - line 85; figures 5-8 -----	

# INTERNATIONAL SEARCH REPORT

Information on patent family members

International Application No

PCT/US2005/004874

Patent document cited in search report	Publication date	Publication date	Patent family member(s)	Publication date
WO 2005002809	A	13-01-2005	NONE	
WO 2004071260	A	26-08-2004	AU 2004210701 A1	26-08-2004
US 2002023351	A1	28-02-2002	AU 2454600 A DE 60001055 D1 DE 60001055 T2 EP 1152872 A1 ES 2184694 T3 WO 0047374 A1	29-08-2000 30-01-2003 17-07-2003 14-11-2001 16-04-2003 17-08-2000
US 5337478	A	16-08-1994	NONE	
US 4238882	A	16-12-1980	NONE	
GB 640185	A	12-07-1950	NONE	