

963,927.

I. OESTERBLOM.
STEAM TURBINE.
APPLICATION FILED JULY 21, 1908.

Patented July 12, 1910.

3 SHEETS—SHEET 1.

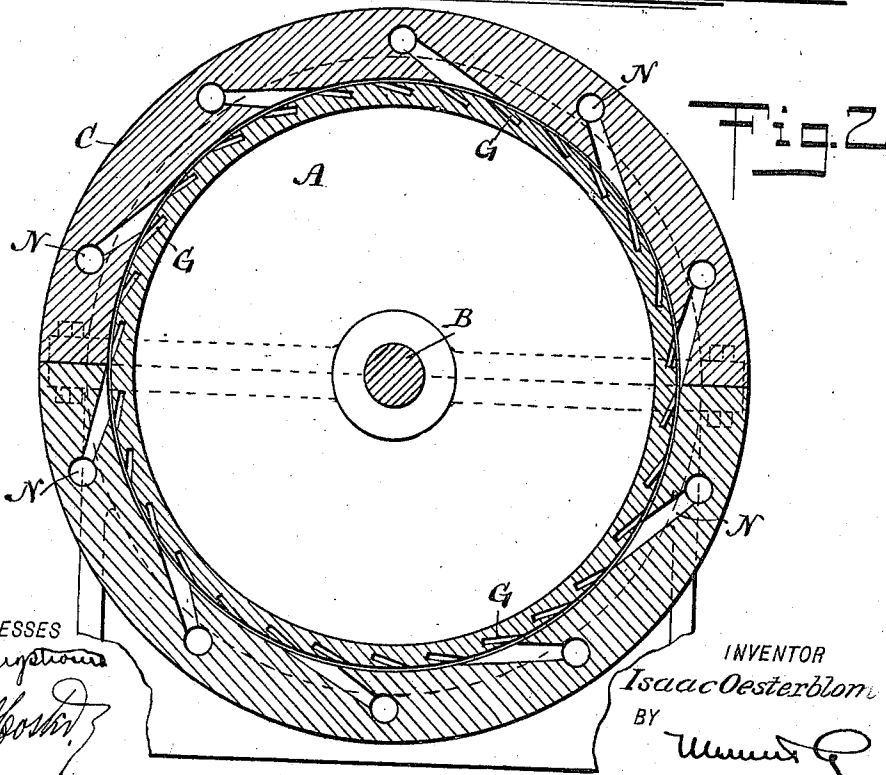
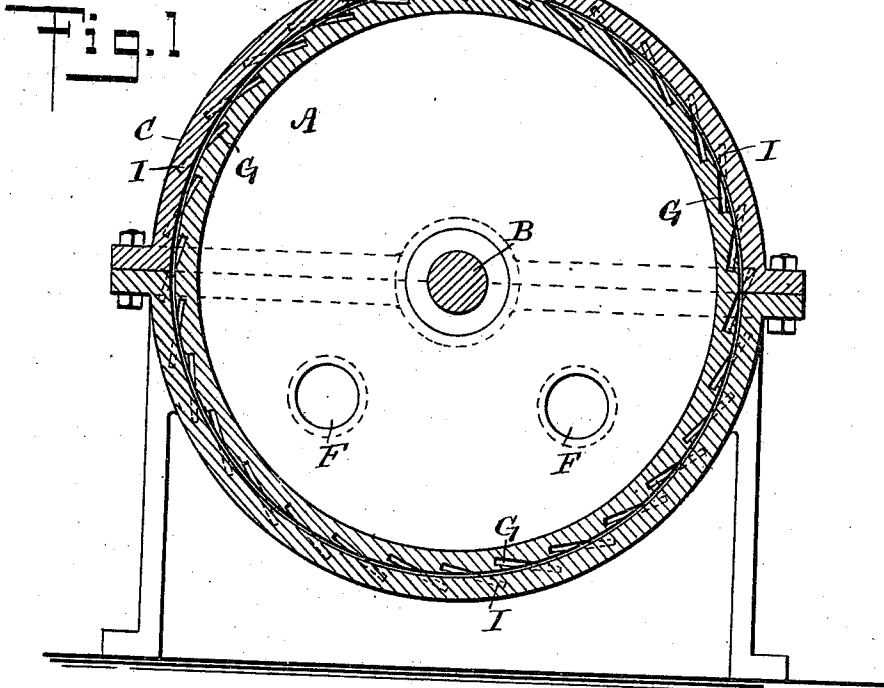

WITNESSES
John Bergstrom
Rev. J. H. ...

INVENTOR
Isaac Oesterblom
BY *Wm. J. ...*
ATTORNEYS

I. OESTERBLOM.

STEAM TURBINE.

APPLICATION FILED JULY 21, 1908.

963,927.

Patented July 12, 1910.

3 SHEETS—SHEET 2.

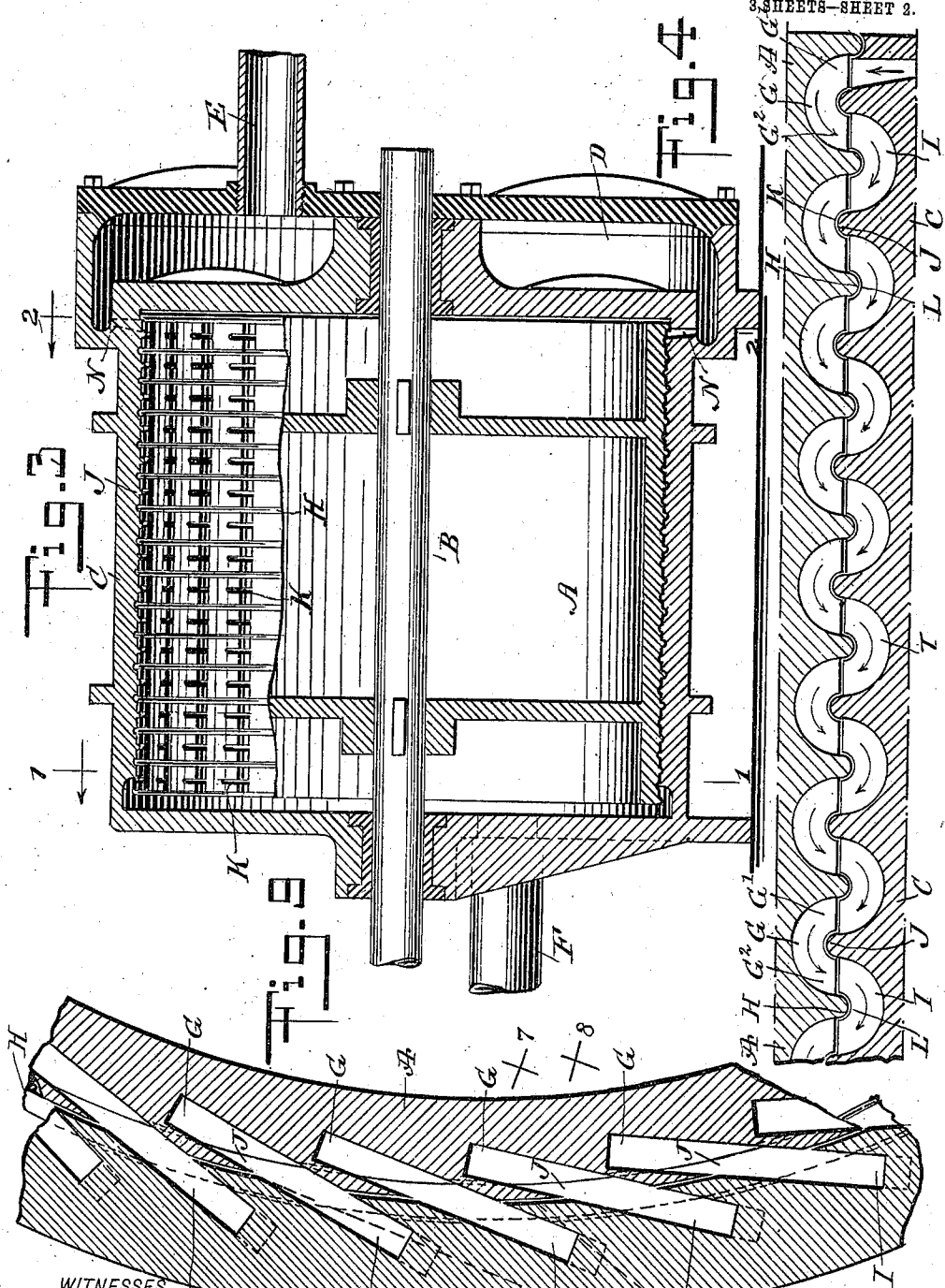

WITNESSES
 John A. Repton
 Rev. H. H. Hooper

INVENTOR
 I. Oesterblom
 BY
 Wm. G. [Signature]
 ATTORNEYS

I. OESTERBLOM.
STEAM TURBINE.

APPLICATION FILED JULY 21, 1908.

Patented July 12, 1910.

963,927.

3 SHEETS—SHEET 3.

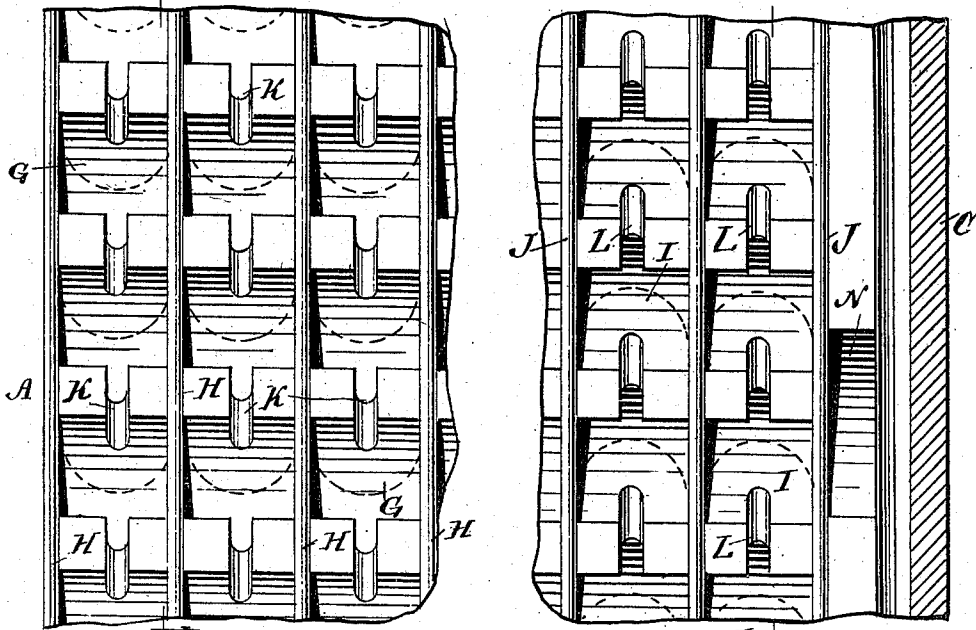

Fig. 5

Fig. 6

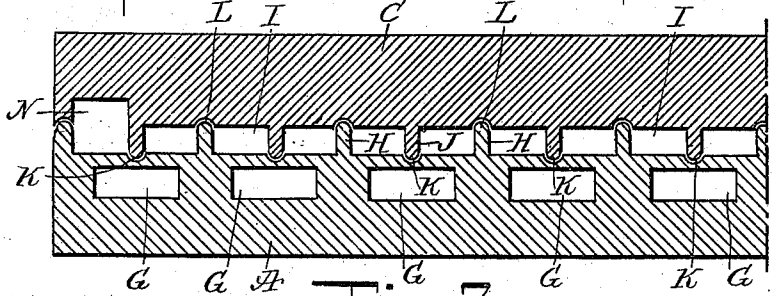

Fig. 7

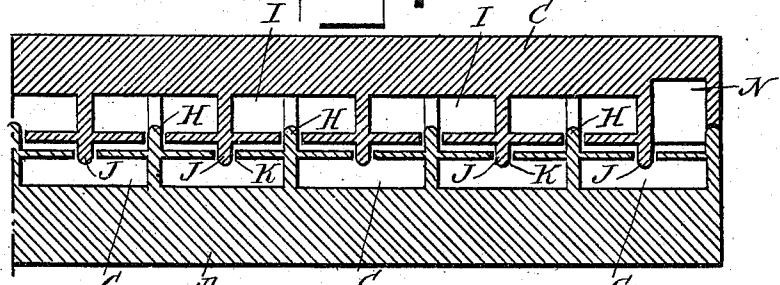

Fig. 8

WITNESSES
John A. Supton
Rev. H. H. Hester

INVENTOR
Isaac Oesterblom
BY *Wm. G. [Signature]*
ATTORNEYS

UNITED STATES PATENT OFFICE.

ISAAC OESTERBLOM, OF NEW YORK, N. Y., ASSIGNOR OF ONE-HALF TO HARRY P. WOOD, OF NEW YORK, N. Y.

STEAM-TURBINE.

963,927.

Specification of Letters Patent. Patented July 12, 1910.

Application filed July 21, 1908. Serial No. 444,637.

To all whom it may concern:

Be it known that I, ISAAC OESTERBLOM, a subject of the King of Sweden, and a resident of the city of New York, borough of Manhattan, in the county and State of New York, have invented a new and Improved Steam-Turbine, of which the following is a full, clear, and exact description.

The object of the invention is to provide a new and improved steam turbine arranged to utilize the steam to the fullest advantage both by impact and reaction, and to provide an unlimited number of reversals of the steam, the steam finally leaving the rotor practically at the same velocity as the peripheral speed of the rotor, thereby causing the residual kinetic energy of the steam to approach zero.

The invention consists of novel features and parts and combinations of the same, which will be more fully described hereinafter and then pointed out in the claims.

A practical embodiment of the invention is represented in the accompanying drawings forming a part of this specification, in which similar characters of reference indicate corresponding parts in all the views.

Figure 1 is a cross section of the improvement on the line 1—1 of Fig. 3; Fig. 2 is a similar view of the same on the line 2—2 of Fig. 3; Fig. 3 is a longitudinal central section of the improvement; Fig. 4 is an enlarged diagrammatic view of the improvement and showing more particularly the passage of the steam through the rotor and stator; Fig. 5 is an enlarged face view of a portion of the rotor; Fig. 6 is an enlarged inner face view of a portion of the stator; Fig. 7 is an enlarged sectional side elevation of the improvement on the line 7—7 of Fig. 9; Fig. 8 is a like view of the same on the line 8—8 of Fig. 9; and Fig. 9 is an enlarged cross section of part of the stator and rotor.

The rotor A has its shaft B journaled in suitable bearings in the stator C, provided at one end with a steam chamber D connected by a pipe E with a boiler or other suitable source of steam supply, the other end of the stator C being provided with an exhaust pipe F for carrying off the exhaust steam.

The rotor A is provided on its peripheral face with impact and reaction chambers G arranged in transverse rows, separated from each other by transversely-extending annu-

lar ribs H, and on the inner face of the stator C are arranged steam guideways I placed in transverse rows, separated from each other by transversely extending annular ribs J passing into grooves K formed in the middle of the corresponding rows of chambers G. The ribs H previously mentioned extend into grooves L formed in the middle of the corresponding rows of steam guideways I, as will be readily understood by reference to Fig. 4.

Each of the chambers G is preferably of U-shape, with the bend forward in the direction of the rotation of the rotor A, and each chamber consists of an impact portion G' and a reaction portion G², the portions G' and G² extending in opposite directions. Each of the guideways I is also of U-shape, with the bend extending in a rearward direction reverse to the rotation of the rotor A, and the chambers G and the guideways I in adjacent rows are so arranged that the outlets of the guideways I in one row are in register with the inlets to the impact portions G' of the opposite row of chambers G, and the outlets of the reaction portions G² of the chambers G in this row are in register with the inlets to the guideways I in the next following row of guideways, as will be readily understood by reference to Fig. 4.

The steam chamber D is preferably connected with the small ends of a plurality of extension nozzles N, arranged in the peripheral wall of the stator C, the nozzles being arranged approximately tangentially relative to the inner surface of the stator C and the peripheral face of the rotor A. The base ends of the nozzles N discharge the steam into the inlet ends of the impact portions G' of the first row of chambers G at the right-hand side of the machine, so that the steam enters the impact portions expanded and at its maximum velocity, and this steam acts in the impact portions G' with impact force to drive the rotor A forward and then the steam passes into the reaction portions G² and out of the same with reactive force, to assist in the forward turning of the rotor A. The steam on leaving the reaction portions G² passes into and through the first row of registering guideways I, in which the direction of the steam is reversed, that is, sent again forward to the inlets of the impact portions G' of the next following row of chambers G, in which the

steam first acts with impact force and then with reactive force, the same as above described in reference to the first row of chambers G, to assist in driving the rotor A forward. The steam on leaving the reaction portions G² of the chambers G of the second row passes to and through the guideways in the second row of guideways, to be then directed to the third row of chambers G, and this performance is repeated throughout the length of the rotor, so that the steam is utilized to the fullest advantage, it being understood that the steam propels the rotor both by impact and by reactive force in each chamber G. The steam finally passes from the outlets of the reaction portions G² of the chambers G in the last row at the left-hand side of the machine into the space between the left ends of the rotor A and the stator C, so that the steam leaves the rotor A practically at the same velocity as the peripheral speed of the rotor, thereby causing the residual kinetic energy of the steam to approach zero.

It is understood that when the turbine is running, the rotor carries the steam along in each chamber until it passes to the corresponding fixed guideway I in the stator C, and in this manner each jet of steam is carried around with the rotor and shifted sideways from the right to the left, somewhat in a spiral direction from the entrance end (right-hand) to the discharge end (left hand) of the turbine, and the steam is used in its spiral travel through the corresponding chambers G with both impact and reactive force.

It is understood that by the arrangement of the chambers and guideways described, an almost unlimited number of reversals of the steam and consequent lowered peripheral velocity of the rotor is had, without complicated, heavy and costly steam passages and a multitude of space-consuming and dangerous clearances, and yet providing a safe working clearance between the rotor and the stator, with all necessary obstructions against steam leakage in a longitudinal direction. In other words, the invention is meant to meet the great demand for a slow speed turbine, although it can be built high speed as well, and with other minor modifications as to details, in all reasonable sizes.

Having thus described my invention, I claim as new and desire to secure by Letters Patent:

1. A steam turbine, comprising a stator having a steam chamber at one end and tan-

gential nozzles leading from the chamber through the peripheral wall of the stator, said stator being provided in its inner face at one end with an annular-groove forming an exhaust chamber, transverse rows of U-shaped steam guideways extending from said groove to the other end of the stator and separated from each other by annular ribs projecting beyond the inner face of the stator, and grooves between the guideways of the several rows of guideways, and a rotor mounted in the stator and having in its peripheral face transverse rows of U-shaped impact and reaction chambers separated from each other by annular ribs projecting beyond the peripheral face of the rotor and grooves between the chambers of the several rows of chambers, the ribs of the stator projecting into the grooves of the rotor and the ribs of the rotor projecting into the grooves of the stator, the rotor having its end extending partially over the annular groove of the stator.

2. A steam turbine, comprising a stator having a steam chamber at one end and nozzles leading from the steam chamber through the peripheral wall of the stator, said stator being provided with return guideways arranged in transverse rows on the inner face of the stator, and a rotor mounted to turn in the said stator and having transverse rows of impact and reaction chambers on its peripheral face, the impact portions of the chambers in one row of chambers registering with the outlet ends of the guideways of the opposite row of guideways, and the reaction portions of the chambers in one row of chambers registering with the inlets of the guideways in the next following row of guideways in the stator, the rows of chambers being separated from each other by annular ribs projecting beyond the peripheral face of the rotor and extending into grooves formed in the middle of the rows of the said guideways, and the rows of guideways being separated from each other by annular ribs projecting from the inner face of the stator and extending into grooves formed in the middle of the said chambers.

In testimony whereof I have signed my name to this specification in the presence of two subscribing witnesses.

ISAAC OESTERBLOM.

Witnesses:

THEO. G. HOSTER,
EVERARD B. MARSHALL.