



- (51) International Patent Classification:
B65D 71/72 (2006.01) B65D 73/00 (2006.01)
B65D 71/42 (2006.01)
- (21) International Application Number:
PCT/US2021/052279
- (22) International Filing Date:
28 September 2021 (28.09.2021)
- (25) Filing Language: English
- (26) Publication Language: English
- (30) Priority Data:
63/085,365 30 September 2020 (30.09.2020) US
63/086,681 02 October 2020 (02.10.2020) US
63/120,863 03 December 2020 (03.12.2020) US
63/136,400 12 January 2021 (12.01.2021) US
63/208,646 09 June 2021 (09.06.2021) US
- (71) Applicant: GRAPHIC PACKAGING INTERNATIONAL, LLC [US/US]; Law Department - 9th Floor, 1500 Riveredge Parkway, Suite 100, Atlanta, GA 30328 (US).
- (72) Inventors: THOMPSON, Jon; 172 Earlstone Crescent, Cadbury Heath, Bristol BS308AJ (GB). GOULD, Steve, M.; 52 Field Farm Close, Stoke Gifford, Bristol BS348XX (GB).
- (74) Agent: CLAERBOUT, Andrew, N.; Womble Bond Dickinson (US) LLP, P.O. Box 7037, Atlanta, GA 30357-0037 (US).
- (81) Designated States (unless otherwise indicated, for every kind of national protection available): AE, AG, AL, AM, AO, AT, AU, AZ, BA, BB, BG, BH, BN, BR, BW, BY, BZ, CA, CH, CL, CN, CO, CR, CU, CZ, DE, DJ, DK, DM, DO, DZ, EC, EE, EG, ES, FI, GB, GD, GE, GH, GM, GT, HN, HR, HU, ID, IL, IN, IR, IS, IT, JO, JP, KE, KG, KH, KN, KP, KR, KW, KZ, LA, LC, LK, LR, LS, LU, LY, MA, MD, ME, MG, MK, MN, MW, MX, MY, MZ, NA, NG, NI, NO, NZ, OM, PA, PE, PG, PH, PL, PT, QA, RO, RS, RU, RW,

(54) Title: CARRIER FOR CONTAINERS

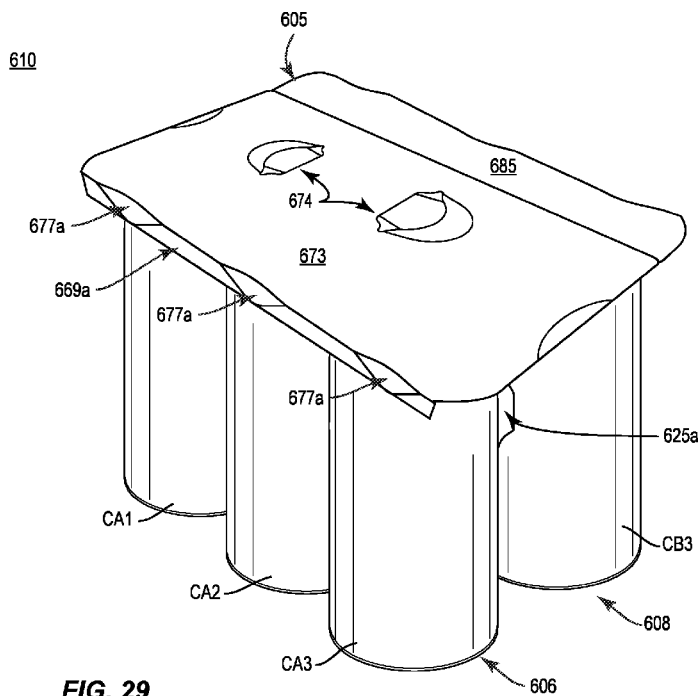

FIG. 29

(57) Abstract: A carrier for holding a plurality of containers includes a plurality of panels including at least one central panel, at least one attachment panel, at least one side panel, and at least one top panel, the at least one attachment panel configured receive a portion of one or more containers of the plurality of containers, and at least one reinforcement panel positioned between the at least one attachment panel and the at least one top panel. The at least one central panel is for being positioned between and attached to adjacent containers of the plurality of containers.



SA, SC, SD, SE, SG, SK, SL, ST, SV, SY, TH, TJ, TM, TN,
TR, TT, TZ, UA, UG, US, UZ, VC, VN, WS, ZA, ZM, ZW.

- (84) Designated States** (*unless otherwise indicated, for every kind of regional protection available*): ARIPO (BW, GH, GM, KE, LR, LS, MW, MZ, NA, RW, SD, SL, ST, SZ, TZ, UG, ZM, ZW), Eurasian (AM, AZ, BY, KG, KZ, RU, TJ, TM), European (AL, AT, BE, BG, CH, CY, CZ, DE, DK, EE, ES, FI, FR, GB, GR, HR, HU, IE, IS, IT, LT, LU, LV, MC, MK, MT, NL, NO, PL, PT, RO, RS, SE, SI, SK, SM, TR), OAPI (BF, BJ, CF, CG, CI, CM, GA, GN, GQ, GW, KM, ML, MR, NE, SN, TD, TG).

Declarations under Rule 4.17:

- *as to applicant's entitlement to apply for and be granted a patent (Rule 4.17(ii))*
- *as to the applicant's entitlement to claim the priority of the earlier application (Rule 4.17(iii))*

Published:

- *with international search report (Art. 21(3))*

CARRIER FOR CONTAINERS**CROSS-REFERENCE TO RELATED APPLICATIONS**

[0001] This application is a continuation-in-part of U.S. Patent Application No. 16/937,043, filed on July 23, 2020, which is a division of U.S. Patent Application No. 16/426,057, filed on May 30, 2019, which claims the benefit of each of U.S. Provisional Patent Application No. 62/779,689, filed on December 14, 2018, U.S. Provisional Patent Application No. 62/783,752, filed on December 21, 2018, U.S. Provisional Patent Application No. 62/796,830, filed on January 25, 2019, U.S. Provisional Patent Application No. 62/797,585, filed on January 28, 2019, U.S. Provisional Patent Application No. 62/810,015, filed on February 25, 2019, U.S. Provisional Patent Application No. 62/814,412, filed on March 6, 2019, U.S. Provisional Patent Application No. 62/817,120, filed on March 12, 2019, and U.S. Provisional Patent Application No. 62/841,449, filed on May 1, 2019. This application also claims the benefit of each of U.S. Provisional Patent Application No. 63/085,365, filed on September 30, 2020, U.S. Provisional Patent Application No. 63/086,681, filed on October 2, 2020, U.S. Provisional Patent Application No. 63/120,863, filed on December 3, 2020, U.S. Provisional Patent Application No. 63/136,400, filed on January 12, 2021, and U.S. Provisional Patent Application No. 63/208,646, filed on June 9, 2021.

INCORPORATION BY REFERENCE

[0002] The disclosures of each of U.S. Provisional Patent Application No. 62/779,689, filed on December 14, 2018, U.S. Provisional Patent Application No. 62/783,752, filed on December 21, 2018, U.S. Provisional Patent Application No. 62/796,830, filed on January 25, 2019, U.S. Provisional Patent Application No. 62/797,585, filed on January 28, 2019, U.S. Provisional Patent Application No. 62/810,015, filed on February 25, 2019, U.S. Provisional Patent Application No. 62/814,412, filed on March 6, 2019, U.S. Provisional Patent Application No. 62/817,120, filed on March 12, 2019, U.S. Provisional Patent Application No. 62/84630227571,449, filed on May 1, 2019, U.S. Patent Application No. 16/426,050, filed on May 30, 2019, U.S. Patent Application No. 16/426,057, filed on May 30, 2019, U.S. Patent Application No. 16/426,060, filed on May 30, 2019, U.S. Patent Application No. 16/426,063, filed on May 30, 2019, U.S. Patent Application No. 16/426,066, filed on May 30, 2019, U.S. Design Patent Application No. 29/692,992, filed on May 30, 2019, U.S. Design Patent Application No. 29/692,993, filed on May 30, 2019, U.S. Design Patent Application No. 29/692,994, filed on May 30, 2019, U.S. Design Patent Application No. 29/692,996, filed on May 30, 2019, U.S. Design Patent Application No. 29/692,997, filed on May 30, 2019, U.S. Patent Application No. 16/598,282, filed on October 10, 2019, U.S. Design Patent Application No. 29/709,918, filed on October 18, 2019, U.S.

Provisional Patent Application No. 62/952,839, filed on December 23, 2019, U.S. Provisional Patent Application No. 62/956,882, filed on January 3, 2020, U.S. Provisional Patent Application No. 62/985,997, filed on March 6, 2020, U.S. Patent Application No. 16/829,346, filed on March 25, 2020, and U.S. Provisional Patent Application No. 63/015,898, filed on April 27, 2020, U.S. Provisional Patent Application No. 63/022,757, filed on May 11, 2020, U.S. Provisional Patent Application No. 63/023,442, filed on May 12, 2020, U.S. Design Patent Application No. 29/735,178, filed on May 19, 2020, U.S. Provisional Patent Application No. 63/031,615, filed on May 29, 2020, U.S. Design Patent Application No. 29/739,927, filed on June 30, 2020, U.S. Design Patent Application No. 29/739,929, filed on June 30, 2020, U.S. Design Patent Application No. 29/739,931, filed on June 30, 2020, U.S. Design Patent Application No. 29/739,933, filed on June 30, 2020, U.S. Design Patent Application No. 29/739,934, filed on June 30, 2020, U.S. Provisional Patent Application No. 63/085,365, filed on September 30, 2020, U.S. Provisional Patent Application No. 63/086,681, filed on October 2, 2020, U.S. Provisional Patent Application No. 63/120,863, filed on December 3, 2020, U.S. Patent Application No. 17/119,040, filed on December 11, 2020, U.S. Patent Application No. 17/118,999, filed on December 11, 2020, U.S. Provisional Patent Application No. 63/136,400, filed on January 12, 2021, U.S. Design Patent Application No. 29/775,557, filed on March 24, 2021, U.S. Design Patent Application No. 29/775,558, filed on March 24, 2021, U.S. Design Patent Application No. 29/775,559, filed on March 24, 2021, U.S. Design Patent Application No. 29/775,560, filed on March 24, 2021, U.S. Provisional Patent Application No. 63/208,568, filed on June 9, 2021, and U.S. Provisional Patent Application No. 63/208,646, filed on June 9, 2021, U.S. Provisional Application No. 62/728,454, filed on September 7, 2018, U.S. Provisional Patent Application No. 62/767,188, filed on November 14, 2018, U.S. Provisional Patent Application No. 62/770,566, filed on November 21, 2018, and U.S. Provisional Patent Application No. 63/214,868, filed on June 25, 2021, U.S. Provisional Patent Application No. 63/216,062, filed on June 29, 2021, and U.S. Provisional Patent Application No. 63/219,648, filed on July 8, 2021, U.S. Provisional Patent Application No. 63/222,225, filed on July 15, 2021, U.S. Provisional Patent Application No. 63/203,882, filed on August 3, 2021, U.S. Provisional Patent Application No. 63/260,881, filed on September 3, 2021, and U.S. Provisional Patent Application No. 63/261,582, filed on September 24, 2021, are hereby incorporated by reference for all purposes as if presented herein in their entirety. The disclosures of each of U.S. Patent No. 8,387,784, issued on March 5, 2013, U.S. Patent No. 8,096,413, issued on January 17, 2012, and U.S. Patent No. 11,027,905, issued on June 8, 2021, are also hereby incorporated by reference for all purposes as if presented herein in their entirety.

BACKGROUND OF THE DISCLOSURE

[0003] The present disclosure generally relates to cartons or carriers for holding, displaying, and/or transporting containers.

SUMMARY OF THE DISCLOSURE

[0004] According to one aspect, the disclosure is generally directed to a carrier for holding a plurality of containers, the carrier comprising a plurality of panels comprising at least one central panel, at least one attachment panel, at least one side panel, and at least one top panel, the at least one attachment panel configured to receive a portion of one or more containers of the plurality of containers, and at least one reinforcement panel positioned between the at least one attachment panel and the at least one top panel. The at least one central panel is for being positioned between and attached to adjacent containers of the plurality of containers.

[0005] According to another aspect, the disclosure is generally directed to a blank for forming a carrier for holding a plurality of containers, the blank comprising a plurality of panels comprising at least one central panel, at least one attachment panel, at least one side panel, and at least one top panel, the at least attachment panel configured to receive a portion of one or more containers of the plurality of containers when the carrier is formed from the blank, and at least one reinforcement panel positioned between the at least one attachment panel and the at least one top panel. The at least one central panel is for being positioned between and attached to adjacent containers of the plurality of containers when the carrier is formed from the blank.

[0006] According to another aspect, the disclosure is generally directed to a method of forming a carrier for holding a plurality of containers, the method comprising obtaining a blank comprising a plurality of panels comprising at least one central panel, at least one attachment panel, at least one side panel, and at least one top panel, the blank further comprising at least one reinforcement panel positioned between the at least one attachment panel and the at least one top panel. The method further comprises folding the plurality of panels to form the carrier such that the at least one attachment panel receives a portion of one or more containers of the plurality of containers, positioning the at least one central panel between adjacent containers of the plurality of containers, and attaching the at least one central panel to adjacent containers of the plurality of containers.

[0007] According to another aspect, the disclosure is generally directed to a package, the package comprising a plurality of containers and a carrier holding the plurality of containers. The carrier comprises a plurality of panels comprising at least one central panel, at least one attachment panel, at least one side panel, and at least one top panel, the at least one attachment panel receiving a portion of

one or more containers of the plurality of containers, and at least one reinforcement panel positioned between the at least one attachment panel and the at least one top panel. The at least one central panel is positioned between and attached to adjacent containers of the plurality of containers.

[0008] Those skilled in the art will appreciate the above stated advantages and other advantages and benefits of various additional embodiments reading the following detailed description of the embodiments with reference to the below-listed drawing figures. It is within the scope of the present disclosure that the above-discussed aspects be provided both individually and in various combinations.

BRIEF DESCRIPTION OF THE DRAWINGS

[0009] According to common practice, the various features of the drawings discussed below are not necessarily drawn to scale. Dimensions of various features and elements in the drawings may be expanded or reduced to more clearly illustrate the embodiments of the disclosure.

[0010] Fig. 1 is a plan view of an outer surface of a blank for forming a carrier according to a first exemplary embodiment of the disclosure.

[0011] Fig. 2 is a perspective view of a partially folded configuration of a carrier formed from the blank of Fig. 1 according to the first exemplary embodiment.

[0012] Fig. 3 is a perspective view of another partially folded configuration of a carrier formed from the blank of Fig. 1 according to the first exemplary embodiment.

[0013] Fig. 4 is a perspective view of another partially folded configuration of a carrier formed from the blank of Fig. 1 according to the first exemplary embodiment and having a container removed.

[0014] Fig. 5 is a perspective view of a package and carrier formed from the blank of Fig. 1 according to the first exemplary embodiment.

[0015] Fig. 6 is a plan view of an outer surface of a blank for forming a carrier according to a second exemplary embodiment of the disclosure.

[0016] Fig. 7 is a perspective view of a partially folded configuration of a carrier formed from the blank of Fig. 6 according to the second exemplary embodiment.

[0017] Fig. 8 is a perspective view of another partially folded configuration of a carrier formed from the blank of Fig. 6 according to the second exemplary embodiment.

- [0018] Fig. 9 is a perspective view of another partially folded configuration of a carrier formed from the blank of Fig. 6 according to the second exemplary embodiment and having a pair of containers removed.
- [0019] Fig. 10 is a perspective view of a package and carrier formed from the blank of Fig. 6 according to the second exemplary embodiment.
- [0020] Fig. 11 is a plan view of an outer surface of a blank for forming a carrier according to a third exemplary embodiment of the disclosure.
- [0021] Fig. 12 is a perspective view of a partially folded configuration of a carrier formed from the blank of Fig. 11 according to the third exemplary embodiment.
- [0022] Fig. 13 is a perspective view of another partially folded configuration of a carrier formed from the blank of Fig. 11 according to the third exemplary embodiment.
- [0023] Fig. 14 is a perspective view of another partially folded configuration of a carrier formed from the blank of Fig. 11 according to the third exemplary embodiment and having a pair of containers removed.
- [0024] Fig. 15 is a perspective view of a package and carrier formed from the blank of Fig. 11 according to the third exemplary embodiment.
- [0025] Fig. 16 is a plan view of an outer surface of a blank for forming a carrier according to a fourth exemplary embodiment of the disclosure.
- [0026] Fig. 17 is a perspective view of a partially folded configuration of a carrier formed from the blank of Fig. 16 according to the fourth exemplary embodiment.
- [0027] Fig. 18 is a perspective view of another partially folded configuration of a carrier formed from the blank of Fig. 16 according to the fourth exemplary embodiment.
- [0028] Fig. 19 is a perspective view of another partially folded configuration of a carrier formed from the blank of Fig. 16 according to the fourth exemplary embodiment and having a container removed.
- [0029] Fig. 20 is another perspective view of another partially folded configuration of a carrier formed from the blank of Fig. 16 according to the fourth exemplary embodiment.

- [0030] Fig. 21 is a perspective view of a package and carrier formed from the blank of Fig. 16 according to the fourth exemplary embodiment.
- [0031] Fig. 22 is a side view of the package and carrier of Fig. 21.
- [0032] Fig. 23 is another perspective view of the package and carrier of Fig. 21.
- [0033] Fig. 24 is a plan view of an outer surface of a blank for forming a carrier and package according to a fifth exemplary embodiment of the disclosure.
- [0034] Fig. 24A is an enlarged view of a portion of the blank of Fig. 24.
- [0035] Fig. 24B is an enlarged view of another portion of the blank of Fig. 24.
- [0036] Fig. 25 is a perspective view of a partially folded configuration of a carrier formed from the blank of Fig. 24 according to the fifth exemplary embodiment.
- [0037] Fig. 26 is another perspective view of a partially folded configuration of a carrier formed from the blank of Fig. 24 according to the fifth exemplary embodiment.
- [0038] Fig. 27 is a front view of a package and carrier formed from the blank of Fig. 24 according to the fifth exemplary embodiment, and having a container removed therefrom.
- [0039] Fig. 28 is a back view of a package and carrier formed from the blank of Fig. 24 according to the fifth exemplary embodiment, and having a container removed therefrom.
- [0040] Fig. 29 is a perspective view of a package and carrier formed from the blank of Fig. 24 according to the fifth exemplary embodiment.
- [0041] Fig. 30 is a perspective view of the package and carrier of Fig. 29, showing a container being withdrawn therefrom.
- [0042] Corresponding parts are designated by corresponding reference numbers throughout the drawings.

DETAILED DESCRIPTION OF THE EXEMPLARY EMBODIMENTS

[0043] The present disclosure generally relates to carriers, packages, constructs, sleeves, cartons, or the like, for holding and displaying containers such as jars, bottles, cans, etc. The containers can be used for packaging food and beverage products, for example. The containers can be made from materials suitable in composition for packaging the particular food or beverage item, and the materials include, but are not limited to, glass; plastics such as PET, LDPE, LLDPE, HDPE, PP, PS, PVC, EVOH, and Nylon; and the like; aluminum and/or other metals; or any combination thereof.

[0044] Carriers according to the present disclosure can accommodate containers of numerous different shapes. For the purpose of illustration and not for the purpose of limiting the scope of the disclosure, the following detailed description describes beverage containers (e.g., aluminum cans) at least partially disposed within the carrier embodiments. In this specification, the terms “lower,” “bottom,” “upper,” “top,” “front,” and “back” indicate orientations determined in relation to fully erected carriers.

[0045] As described herein, carriers may be formed by multiple overlapping panels, end flaps, and/or other portions of blanks. Such panels, end flaps, and/or other portions of the blank can be designated in relative terms to one another, e.g., “first”, “second”, “third”, etc., in sequential or non-sequential reference, without departing from the disclosure.

[0046] Fig. 1 shows a plan view of an exterior side 201 of a blank 203 used to form a carrier 205 (Fig. 5) in accordance with a first exemplary embodiment of the disclosure. As shown in Fig. 5, the carrier 205 is sized to contain or support four containers, with two containers CA1, CA2 being attached to a front portion 206 of the carrier 205 and two containers CB1, CB2 being attached to a back portion 208 of the carrier 205. In the illustrated embodiment, the containers CA1, CA2, CB1, CB2, can be beverage cans, or could be any other suitable type and size of container without departing from the disclosure. The carrier 205 can be sized and shaped to hold more or less than four containers. In one embodiment, the front portion 206 and the back portion 208 of the carrier 205 each have two containers, and in other embodiments, the front portion 206 and the back portion 208 of the carrier 205 can carry more or less than two containers without departing from the disclosure. The carrier 205 can be provided together with one or more container as a package 210 (Fig. 5).

[0047] As shown in Fig. 1, the blank 203 has a longitudinal axis L1 and a lateral axis L2. The blank 203 has a front portion 207 for forming the front portion 206 of the carrier 205, and a back portion 209 for forming the back portion 208 of the carrier 205. The front portion 207 and the back portion 209 of the blank 203 are foldably connected at a lateral fold line 212 that forms a lateral centerline CL of the blank 203, as shown. As discussed in further detail below, the blank 203 is partially formed into the

carrier 205 by folding the blank 203 at the fold line 212 along the centerline CL so that the front portion 207 and the back portion 209 of the blank 203 are overlapped in at least partial face-to-face contact.

[0048] In the illustrated embodiment, the front portion 207 of the blank 203 comprises a front central panel 225a having a pair of adhesive or glue openings 227a at interior portions thereof and a pair of surface features 229a adjacent the respective glue openings 227a. The surface features 229a can be, for example, an embossed feature or other at least partially raised or recessed surface configuration. As described further herein, the front central panel 225a is bisected or otherwise partitioned by a handle opening 230 that extends from a portion of the front portion 207 of the blank 203 and across the centerline CL to a portion of the back portion 209 of the blank 203. As also described further herein, for example, the top edges of the respective glue openings 227a are spaced a longitudinal distance D1 away from the centerline CL that is greater than a longitudinal distance D2 that the top edges of respective glue openings 227b of the back portion 209 of the blank 203 are spaced away from the centerline CL.

[0049] A front container retention panel or front attachment panel 231a is foldably connected to the front central panel 225a at a lateral fold line 233a that is interrupted by an end portion of the handle opening 230. The front attachment panel 231a includes a container retention portion 235a that is at least partially defined between a pair of longitudinally-spaced lateral fold lines 237a, 239a that are each interrupted by a respective pair of longitudinally-spaced cuts 241a that can each include one or more curved and/or angled portions. As shown, the longitudinally-spaced cuts 241a define container retention tabs 248a that extend outwardly from the container retention portion 235a. As also shown, respective oblique cuts 243a, 245a extend outwardly from each respective cut 241a to define a respective pair of container retention flaps 247a, 249a that are foldably connected to the front attachment panel 231a at respective oblique fold lines 251a, 253a.

[0050] As shown, an interior marginal portion 236a of the attachment panel 231a is defined between the fold lines 237a, 233a, and an exterior marginal portion 238a of the attachment panel 231a is defined between the fold line 239a and a lateral fold line 257a adjacent the attachment panel 231a. A bevel or front side panel 255a, as shown, is foldably connected to the front attachment panel 231a at the lateral fold line 257a, and a top panel 259 is foldably connected to the front side panel 255a at a lateral fold line 261a. The top panel 259, as shown, includes handle features that include a pair of opposed curved cuts 263, 265 and a lateral cut 267 extending from the curved cut 263 to the curved cut 265 to define a pair of handle flaps 269, 271 that are foldably connected to the top panel 259 at respective lateral fold lines 273, 275. As described herein, the handle flaps 269, 271 can be folded away from the top panel 259 to form an opening in the top panel 259. A relief cut 270 can extend from a portion of the handle

flap 269, across the cut 267, and onto a portion of the handle flap 271. Handle features of the carrier 205 include the handle features in the top panel 259, and can also include the handle opening 230. The carrier 205 can have a different arrangement of handle features, or can be devoid of handle features, without departing from the disclosure.

[0051] In the illustrated embodiment, the back portion 209 of the blank 203 includes a back central panel 225b, a back container retention panel or back attachment panel 231b, and a back side panel 255b having associated features that are generally a mirror-image of the corresponding panels and flaps of the front portion 207 of the blank 203. Corresponding components (e.g., panels, flaps, fold lines, cuts, etc.) have been designated by corresponding reference numbers that differ by the “a” or “b” suffix, with the “a” components corresponding to the front portion 207 of the blank 203 and the “b” components corresponding to the back portion 209 of the blank 203. The back portion 209 of the blank 203 also includes an attachment flap 277 foldably connected to the back side panel 255b at a lateral fold line 261b.

[0052] As also shown, glue G can be applied to one or more portions of the central panels 225a, 225b, e.g., across the respective surface features 229a, 229b. While the glue G is illustrated on the exterior surface 201 of the blank 203 in Fig. 11 for clarity of illustration and to indicate positioning relative to other features of the blank 203, it will be understood that the glue G is applied to at least the interior surface of the central panels 225a, 225b. In one embodiment, glue G can be applied to both the interior surface and the exterior surface of the central panels 225a, 225b.

[0053] Any of the panels, flaps, fold lines, cuts, or other features could be otherwise shaped, arranged, and/or omitted from the blank 203 without departing from the disclosure. The blank 203 could be sized and/or shaped to accommodate more or less than four containers without departing from this disclosure.

[0054] As shown in Fig. 2 (in which the glue G is omitted for clarity of illustration), the exterior surface 201 of the blank 203 can be placed atop the containers CA1, CA2, CB1, CB2 such that the container retention portion 235a of the front attachment panel 231a overlies the containers CA1, CA2 and such that the container retention portion 235b of the back attachment panel 231b overlies the containers CB1, CB2. Further downward positioning of the attachment panels 231a, 231b over the plurality of containers CA1, CA2, CB1, CB2 can activate the respective container retention portions 235a, 235b to engage respective containers. For example, as the front attachment panel 231a is lowered or urged downwardly onto the containers CA1, CA2, the container retention portion 235a can at least partially separate from the remainder of the front attachment panel 231a at the cuts 241a, which, in turn, can cause additional separation of the respective container retention flaps 247a, 249a from the remainder of the front attachment panel 231a at the respective cuts 243a, 245a and such that the respective container

retention flaps 247a, 249a fold at least partially outwardly from the front attachment panel 231a at the respective fold lines 251a, 253a. In such an arrangement, upper or top portions T of the respective containers CA1, CA2 can extend at least partially through respective openings formed by the respective cuts 241a. Such reconfiguration of the corresponding portions of the back attachment panel 231b can occur as the back attachment panel 231b is lowered or urged downwardly onto the containers CB1, CB2. The marginal portions 236a, 238a of the attachment panel 231a can fold at least partially downwardly at the respective fold lines 237a, 239a in such a configuration, and, similarly, the marginal portions 236b, 238b of the attachment panel 231b can fold at least partially downwardly at the respective fold lines 237b, 239b.

[0055] In this regard, the respective container retention flaps 247a, 249a and/or the respective container retention tabs 248a can engage a portion of the respective containers CA1, CA2, for example, an edge presented by a rim or top portion T of the respective containers CA1, CA2. It will be understood that other portions of the front attachment panel 231a can form a portion of the container retention portion 235a, for example, a portion of the front attachment panel 231a, disposed between the respective container retention flaps 247a, 249a, which can engage an edge presented by a rim or top portion T of the respective containers CA1, CA2 as described above. The back attachment panel 231b and corresponding container retention portion 235b can engage the containers CB1, CB2 in a similar manner as described above with respect to the engagement of the front attachment panel 231a and container retention portion 235a with respect to the containers CA1, CA2.

[0056] As shown in Fig. 2, the front central panel 225a and the back central panel 225b can be folded at the fold line 212 in the direction of the arrows A1, A2 such that the front central panel 225a and the back central panel 225b are brought into at least partial face-to-face contact in the direction of the respective arrows A3, A4 (Fig. 3) and such that the respective glue openings 227a, 227b and the respective surface features 229a, 229b in the respective central panels 225a, 225b are positioned so as to be laterally aligned but longitudinally offset due to the different relative spacing of the respective glue openings 227a, 227b away from the centerline CL. In this regard, the central panels 225a, 225b are arranged such that a portion of the front central panel 225a overlaps each of the glue openings 227b and a portion of the back central panel 225b overlaps each of the glue openings 227a to provide communication between the central panels 225a, 225b and respective surfaces upon which the respective containers CA1, CA2, CB1, CB2 can be adhered or otherwise attached, as described further herein. Such rearrangement of the central panels 225a, 225b can also cause the respective central panels 225a, 225b to be folded downwardly relative to the respective attachment panels 231a, 231b at the respective fold lines 233a, 233b.

[0057] Referring to Fig. 4, in which the container CA1 is removed for clarity of illustration, glue G can be at least partially aligned with the glue openings 227a to adhere the containers CA1, CA2 to respective exposed portions of the central panel 225b through the respective glue openings 227a, and the glue G can be at least partially aligned with the respective glue openings 227b to adhere the containers CB1 and CB2 to respective exposed portions of the central panel 225a through the respective glue openings 227b. The glue G can cover at least a portion of the surface features 229a, 229b such that one or more of the surface features 229a, 229b presents additional surfaces for adhesion and/or spacing between the front portion 206 and the back portion 208 of the carrier 205.

[0058] The attachment of the containers CA1, CA2, CB1, CB2 to the respective central panels 225a, 225b can provide retention and support of the respective containers, e.g., such that the containers do not detach from the carrier 205 under their own weight, in addition to or alternative to the container retention and support provided by the respective container retention portions 235a, 235b. For example, in one embodiment, one or more of the containers CA1, CA2, CB1, CB2 can be attached to a respective central panel 225a, 225b with glue G, without additional retention and support provided by a container retention portion as described above.

[0059] The glue G described herein can be, for example, a hot melt adhesive, a high tack glue, an epoxy, a polymeric cement, etc., or combinations thereof.

[0060] Such enhanced attachment of the respective containers to the respective central panels 225a, 225b with the glue G can also provide enhanced integrity to the carrier 205, e.g., by providing opposing adhesive forces on the respective central panels 225a, 225b such that the central panels 225a, 225b are compressed therebetween. For example, in one embodiment, as the carrier 205 is lifted, the containers CA1, CA2 can at least partially pull the portions of the back central panel 225b to which they are attached through the respective glue openings 227a toward the front central panel 225a under the at least partial weight of the containers CA1, CA2. Respective portions of the front central panel 225a can be pulled toward the back central panel 225b through the respective glue openings 227b by the containers CB1, CB2 in a similar manner.

[0061] Still referring to Figs. 1-5, the front side panel 255a can be folded upwardly at the fold line 257a in the direction of the arrow A5, for example, to be at an oblique arrangement relative to the containers CA1, CA2, CB1, CB2 and the top panel 259 can be folded at the fold line 261a in the direction of the arrow A5 into at least partial face-to-face contact with at least a portion of the attachment panels 231a, 231b. Similarly, the back side panel 255b can be folded upwardly at the fold line 257b in the direction of the arrow A6 into an oblique arrangement with the containers CA1, CA2, CB1, CB2, and the attachment flap 277 can be folded at the fold line 261b in the direction of the arrow A6 into at

least partial face-to-face contact with the top panel 259 and/or the attachment panel 231b, as shown in Fig. 5. Such an arrangement can be maintained with an adhesive such as glue.

[0062] Accordingly, containers can be engaged by the respective attachment panels 231a, 231b and can extend below the respective container retention portions 235a, 235b in the assembled carrier 205/package 210. In such an arrangement, the containers CA1, CA2 extend below the container retention portion 235a in the front portion 206 of the carrier 205, and the containers CB1, CB2 extend below the container retention portion 235b in the back portion 208 of the carrier 205, with the top panel 259 and the attachment flap 277 overlying respective portions of the respective container retention portions 235a, 235b. Further, the front central panel 225a and the back central panel 225b are positioned between and attached to respective ones of the containers CA1, CA2, CB1, CB2.

[0063] Still referring to Figs. 1-5, the carrier 205 can be grasped by separating one or both of the handle flaps 269, 271 at the respective cuts 263, 265, 267 and folding the respective handle flaps 269, 271 downwardly at the respective fold lines 273, 275 toward the handle opening 230 such that a user can insert one or more fingers therethrough to grasp a portion of the package 210/carrier 205, for example, an underside of the top panel 259 and/or the attachment panels 231a, 231b. The alignment of the handle opening 230 below the handle features in the top panel 259, e.g., handle flaps 269, 271 in the erected package 210/carrier 205 provides a space through which the consumer's fingers can extend below the top panel 259 into an interior portion of the carrier 205.

[0064] The package 210/carrier 205 described above has a compact structure that can, for example, provide materials savings and waste reduction. Additionally, the arrangement of the glue G among the containers CA1, CA2, CB1, CB2 as well as the central panels 225a, 225b provides multiple points of attachment that results in a robust structure for holding and carrying the containers CA1, CA2, CB1, CB2. Further, the exposure of one or more portions of the containers CA1, CA2, CB1, CB2 on exterior portions of the carrier 205/package 210 provides a consumer with a clear view of labeling or surface graphics associated with the containers CA1, CA2, CB1, CB2, as well as providing convenient access to remove one or more of the containers CA1, CA2, CB1, CB2 from the carrier 205/package 210, for example, by peeling a respective container away from an adjacent container and/or portion of the carrier 205/package 210. Peeling or pulling the containers CA1, CA2, CB1, CB2 away from a respective central panel 225a, 225b can involve pulling the respective container with a force sufficient to overcome the adhesive bond of the respective container and the respective central panel 225a, 225b provided by the glue G. In one embodiment, the glue G can be selected so as to remain on a respective central panel 225a, 225b, e.g., such that substantially little or no glue G remains on the container as it is removed. One or more of the containers CA1, CA2, CB1, CB2, in one embodiment, can be reattached to a

respective central panel 225a, 225b following therefrom by pressing the container against a respective region of glue G.

[0065] Fig. 6 is a plan view of the exterior side 301 of a blank, generally indicated at 303, used to form a carrier 305 (Fig. 10) for containing one or more containers according to a second exemplary embodiment of the disclosure. The blank 303 and the carrier 305 formed therefrom can have one or more features that are substantially similar to the blank 203 (Fig. 1) and the carrier 205 (Fig. 5) of the first exemplary embodiment of the disclosure, and like or similar components are referenced with like or similar reference numbers.

[0066] As shown, the blank 303 includes a front portion 307 and a back portion 309 and includes additional container retention features such that the respective container retention portions 235a, 235b are configured to engage and support three containers CA1, CA2, CA3 in the front portion 306 of the carrier 305 formed from the blank 303 and three containers CB1, CB2, CB3 in the back portion 308 of the carrier 305. In this regard, the central panels 225a, 225b of the blank 303 are partitioned by a pair of handle openings 230 (broadly, respective “first handle opening” and “second handle opening”), each having marginal portions that extend into the respective attachment panels 231, 231b.

[0067] Furthermore, the cuts 241a, 241b, 243a, 243b, 245a, 245b can form a plurality of flexible edges in the respective container retention portions 235a, 235b for engaging top portions of respective containers, as well as defining the container retention tabs 248a, 248b that extend away from the respective container retention portions 235a, 235b.

[0068] As shown, the top panel 259 of the blank 303 includes handle features that include a pair of handle flaps 363 (broadly, respective “first handle feature” and “second handle feature”) that are each foldably connected to the top panel 259 at a respective fold line 365 and which are at least partially defined by a respective curved cut 367 that extends from one endpoint to the other endpoint of each respective fold line 365. Each handle flap 363 includes respective oblique fold lines 369, 371 that extend from the endpoints of the respective fold line 365 to intersect at the respective cut 367. A consumer can separate the respective handle flaps 363 at the respective cuts 367 and fold the handle flaps 363 downwardly at the respective fold lines 265 to form openings in the top panel 259 that provide access to a respective handle opening 230 to insert one or more fingers therethrough to grasp a portion of the carrier 305 formed from the blank 303, for example, an underside of the top panel 259 and/or the attachment panels 231a, 231b. One or more portions of the respective handle flaps 363 can fold at one or more of the respective oblique fold lines 369, 371, for example, to provide additional protection for the consumer’s fingers and/or to provide separation among adjacent containers. Handle features of the carrier 305 include the handle features in the top panel 259, and can also include the handle openings

230. The carrier 305 can have a different arrangement of handle features, or can be devoid of handle features, without departing from the disclosure.

[0069] As also shown, glue G can be applied to one or more portions of the central panels 225a, 225b, e.g., across the respective surface features 229a, 229b. While the glue G is illustrated on the exterior surface 301 of the blank 303 in Fig. 6 for clarity of illustration and to indicate positioning relative to other features of the blank 303, it will be understood that the glue G is applied to at least the interior surface of the central panels 225a, 225b. In one embodiment, glue G can be applied to both the interior surface and the exterior surface of the central panels 225a, 225b.

[0070] Referring additionally to Figs. 7-10, formation of the carrier 305 from the blank 303 and an associated package 310 that includes the containers CA1, CA2, CA3, CB1, CB2, CB3 is illustrated according to one exemplary embodiment of the disclosure. It will be understood that the carrier 305 can be formed in a similar manner to that of the carrier 205 described above and as shown in Figs. 2-5, and is provided with at least similar properties and advantages.

[0071] As shown in Fig. 7, the exterior surface 301 of the blank 303 can be placed atop the containers CA1, CA2, CB1, CB2, CB3 such that the container retention portion 235a of the front attachment panel 231a overlies the containers CA1, CA2, CA3 and such that the container retention portion 235b of the back attachment panel 231b overlies the containers CB1, CB2, CB3. Further downward positioning of the attachment panels 231a, 231b over the plurality of containers CA1, CA2, CA3, CB1, CB2, CB3 can activate the respective container retention portions 235a, 235b to engage respective containers. For example, as the front attachment panel 231a is lowered or urged downwardly onto the containers CA1, CA2, CA3 the container retention portion 235a can at least partially separate from the remainder of the front attachment panel 231a at the cuts 241a such that an upper or top portion T of the respective containers CA1, CA2, CA3 can at least partially protrude through respective openings formed by the respective cuts 241a. Such reconfiguration of the corresponding portions of the back attachment panel 231b can occur as the back attachment panel 231b is lowered or urged downwardly onto the containers CB1, CB2, CB3. The marginal portions 236a, 238a of the attachment panel 231a can fold at least partially downwardly at the respective fold lines 237a, 239a in such a configuration, and, similarly, the marginal portions 236b, 238b of the attachment panel 231b can fold at least partially downwardly at the respective fold lines 237b, 239b.

[0072] In this regard, portions of the container retention portion 235a, e.g., the container retention tabs 248a, can engage one or more portions of the respective containers CA1, CA2, CA3, for example, an edge presented by a rim or top portion T of the respective containers CA1, CA2, CA3. It will be understood that other portions of the front attachment panel 231a can form a portion of the container

retention portion 235a, for example, a portion of the front attachment panel 231a disposed between and/or adjacent the respective cuts 243a, 245a, which can engage an edge presented by the rim or top portion T of the respective containers CA1, CA2, CA3 as described above. The back attachment panel 231b and corresponding container retention portion 235b can engage the containers CB1, CB2, CB3 in a similar manner as described above with respect to the engagement of the front attachment panel 231a and container retention portion 235a with respect to the containers CA1, CA2, CA3.

[0073] The front central panel 225a and the back central panel 225b can be folded at the fold line 212 and brought into at least partial face-to-face contact in the direction of the respective arrows A7, A8, and such that the respective glue openings 227a, 227b are positioned to be in general alignment so as to be laterally aligned but longitudinally offset. In this regard, the central panels 225a, 225b are arranged such that a portion of the front central panel 225a overlaps each of the glue openings 227b and a portion of the back central panel 225b overlaps each of the glue openings 227a to provide communication between the central panels 225a, 225b and respective surfaces upon which the respective containers CA1, CA2, CA3 and CB1, CB2, CB3 can be adhered or otherwise attached, as described further herein.

[0074] As shown in Fig. 9, in which the container CA2 is removed for clarity of illustration, glue G can be provided in alignment with the glue openings 227a to adhere the containers CA1, CA2, CA3 to respective exposed portions of the central panel 225b through the respective glue openings 227a, and the glue G can be provided in alignment with the glue openings 227b to adhere the containers CB1, CB2, CB3 to respective exposed portions of the central panel 225a through the respective glue openings 227b. In one embodiment, the glue G can cover at least a portion of the surface features 229a, 229b such that one or more of the surface features 229a, 229b presents additional surfaces for adhesion and/or spacing between the front portion 306 and the back portion 308 of the carrier 305.

[0075] As described above, the adhesion of the containers of the front portion 306 of the carrier 305 to respective surfaces of the back central panel 225b exposed through the glue openings 227a, and the adhesion of the containers of the back portion 308 of the carrier 305 to respective surfaces of the front central panel 225a exposed through the glue openings 227b can provide compression between the central panels 225a, 225b and stability to the carrier 305. The containers can be attached to the respective central panels 225a, 225b in a different configuration as described above, e.g., a configuration in which the containers are not engaged by a container retention portion or a configuration in which a fewer number of or no glue openings are provided.

[0076] Still referring to Figs. 7-10, the front side panel 255a can be folded upwardly at the fold line 257a in the direction of the arrow A9, for example, to be at an oblique arrangement relative to the containers CA1, CA2, CA3, CB1, CB2, CB3, and the top panel 259 can be folded at the fold line 261a

in the direction of the arrow A9 into at least partial face-to-face contact with at least a portion of the attachment panels 231a, 231b. Similarly, the back side panel 255b can be folded upwardly at the fold line 257b in the direction of the arrow A10 into an oblique arrangement with the containers CA1, CA2, CA3, CB1, CB2, CB3, and the attachment flap 277 can be folded at the fold line 261b in the direction of the arrow A10 into at least partial face-to-face contact with the top panel 259 and/or the attachment panel 231b.

[0077] Accordingly, containers can be engaged by the respective attachment panels 231a, 231b and can extend below the respective container retention portions 235a, 235b in the assembled carrier 305/package 310. In such an arrangement, containers CA1, CA2, CA3 extend below the container retention portion 235a in the front portion 306 of the carrier 305, and containers CB1, CB2, CB3 extend below the container retention portion 235b in the back portion 308 of the carrier 305, with the top panel 259 and the attachment flap 277 overlying respective portions of the respective container retention portions 235a, 235b. Further, the front central panel 225a and the back central panel 225b are positioned between and attached to respective ones of the containers CA1, CA2, CA3, CB1, CB2, CB3.

[0078] The carrier 305 can be grasped by separating one or both of the handle flaps 363 at the respective cuts 367 and folding the respective handle flaps 363 downwardly at the respective fold lines 365 toward the respective openings 230 such that a user can insert one or more fingers therethrough to grasp a portion of the carrier 305, for example, an underside of the top panel 259 and/or the attachment panels 231a, 231b. The alignment of the respective handle openings 230 below the respective handle features in the top panel 259, e.g., handle flaps 363, in the erected carrier 305 provides a space through which the user's fingers can extend below the top panel 259 into an interior portion of the carrier 305. The handle flaps 363 are configured to at least partially fold at one or both of the respective fold lines 369, 371, for example, to at least partially conform around a respective container CA1, CA2, CA3, CB1, CB2, CB3.

[0079] The configuration of the carrier 305/package 310 provides a compact and robust holding and carrying structure for the containers CA1, CA2, CA3, CB1, CB2, CB3, with the advantages described above with respect to the carrier 205/package 210.

[0080] Fig. 11 is a plan view of the exterior side 401 of a blank, generally indicated at 403, used to form a carrier 405 (Fig. 15) for containing one or more containers according to a third exemplary embodiment of the disclosure. The blank 403 and the carrier 405 formed therefrom can have one or more substantially similar features to the blanks 203, 303 (Figs. 1 and 6) and the carriers 205, 305 (Figs. 5 and 10) described above, and like or similar components are referenced with like or similar reference numbers.

[0081] As shown, the blank 403 includes a front portion 407 and a back portion 409 and includes container retention features such that respective container retention portions 435a, 435b are configured to engage and support three containers in the front portion 406 of the carrier 405 and three containers in the back portion 408 of the carrier 405 formed from the blank 403. The central panels 225a, 225b of the blank 403 are each partitioned by respective handle openings 430a, 430b (broadly, respective “first handle opening” and “second handle opening”) that extend from each respective central panel 225a, 225b into the respective attachment panels 431a, 431b.

[0082] The respective container retention portions 435a, 435b of the respective attachment panels 431a, 431b include the respective lateral fold lines 239a, 239b, interrupted by the respective cuts 241a, 243a, 245a and 241b, 243b, 245b that can form a plurality of flexible edges in the respective container retention portions 235a, 235b for engaging top portions of respective containers, as well as defining the container retention tabs 248a, 248b that extend away from the respective container retention portions 235a, 235b. As shown, an exterior marginal portion 438a of the attachment panel 431a is defined between the fold line 239a and the lateral fold line 257a adjacent the attachment panel 431a.

[0083] As shown, the top panel 259 of the blank 403 includes handle features that include a top handle opening 463 that is laterally aligned with the respective handle openings 430a, 430b. Handle features of the carrier 405 include the handle features in the top panel 259, and can also include the handle openings 430a, 430b. The carrier 405 can have a different arrangement of handle features, or can be devoid of handle features, without departing from the disclosure.

[0084] As also shown, glue G can be applied to one or more portions of the central panels 225a, 225b, e.g., across the respective surface features 229a, 229b. While the glue G is illustrated on the exterior surface 401 of the blank 403 in Fig. 11 for clarity of illustration and to indicate positioning relative to other features of the blank 403, it will be understood that the glue G is applied to at least the interior surface of the central panels 225a, 225b. In one embodiment, glue G can be applied to both the interior surface and the exterior surface of the central panels 225a, 225b.

[0085] Referring additionally to Figs. 12-15, formation of the carrier 405 from the blank 403 and an associated package 410 that includes the containers CA1, CA2, CA3, CB1, CB2, CB3 is illustrated according to one exemplary embodiment of the disclosure. It will be understood that the carrier 405 can be formed in a similar manner to that of the carriers 205, 305 described above and is provided with at least similar properties and advantages.

[0086] As shown in Fig. 12 (in which the glue G is omitted for clarity of illustration), the exterior surface 401 of the blank 403 can be placed atop the containers CA1, CA2, CB1, CB2, CB3 such that the container retention portion 435a of the front attachment panel 431a overlies the containers CA1, CA2, CA3 and such that the container retention portion 435b of the back attachment panel 431b overlies the containers CB1, CB2, CB3. Further downward positioning of the attachment panels 431a, 431b over the plurality of containers CA1, CA2, CA3, CB1, CB2, CB3 can activate the respective container retention portions 435a, 435b to engage respective containers. For example, as the front attachment panel 431a is lowered or urged downwardly onto the containers CA1, CA2, CA3 the container retention portion 435a can at least partially separate from the remainder of the front attachment panel 431a at the cuts 241a such that an upper or top portion T of the respective containers CA1, CA2, CA3 can at least partially protrude through respective openings formed by the respective cuts 241a. Such reconfiguration of the corresponding portions of the back attachment panel 431b can occur as the back attachment panel 431b is lowered or urged downwardly onto the containers CB1, CB2, CB3. The marginal portion 438a of the attachment panel 431a can fold at least partially downwardly at the fold line 239a in such a configuration, and, similarly, the marginal portion 238b of the attachment panel 231b can fold at least partially downwardly at the fold line 239b.

[0087] In this regard, portions of the container retention portion 435a, e.g., the container retention tabs 438a, can engage one or more portions of the respective containers CA1, CA2, CA3, for example, an edge presented by a rim or top portion T of the respective containers CA1, CA2, CA3. It will be understood that other portions of the front attachment panel 231a can form a portion of the container retention portion 435a, for example, a portion of the front attachment panel 431a disposed between and/or adjacent the respective cuts 243a, 245a, which can engage an edge presented by the rim or top portion T of the respective containers CA1, CA2, CA3 as described above. The back attachment panel 431b and corresponding container retention portion 435b can engage the containers CB1, CB2, CB3 in a similar manner as described above with respect to the engagement of the front attachment panel 431a and container retention portion 435a with respect to the containers CA1, CA2, CA3.

[0088] The front central panel 225a and the back central panel 225b can be folded at the fold line 212 and brought into at least partial face-to-face contact in the direction of the respective arrows A11, A12, and such that the respective glue openings 227a, 227b are in general alignment and positioned so as to be laterally aligned but longitudinally offset. In this regard, the central panels 225a, 225b are arranged such that a portion of the front central panel 225a overlaps each of the glue openings 227b and a portion of the back central panel 225b overlaps each of the glue openings 227a to provide communication between the central panels 225a, 225b and respective surfaces upon which the respective containers CA1, CA2, CA3 and CB1, CB2, CB3 can be adhered or otherwise attached, as described further herein.

[0089] As shown in Fig. 14, in which the containers CA2, CB2 are removed for clarity of illustration, glue G can be provided in alignment with the glue openings 227a to adhere the containers CA1, CA2, CA3 to respective exposed portions of the central panel 225b through the respective glue openings 227a, and the glue G can be provided in alignment with the glue openings 227b to adhere the containers CB1, CB2, CB3 to respective exposed portions of the central panel 225a through the respective glue openings 227b. The glue G can cover at least a portion of the surface features 229a, 229b such that one or more of the surface features 229a, 229b presents additional surfaces for adhesion and/or spacing between the front portion 206 and the back portion 408 of the carrier 405.

[0090] As described above, the adhesion of the containers of the front portion 406 of the carrier 405 to respective surfaces of the back central panel 225b exposed through the glue openings 227a, and the adhesion of the containers of the back portion 408 of the carrier 405 to respective surfaces of the front central panel 225a exposed through the glue openings 227b can provide compression between the central panels 225a, 225b and stability to the carrier 405. The containers can be attached to the respective central panels 225a, 225b in a different configuration as described above, e.g., a configuration in which the containers are not engaged by a container retention portion or a configuration in which a fewer number of or no glue openings are provided.

[0091] Still referring to Figs. 12-15, the front side panel 255a can be folded upwardly at the fold line 257a in the direction of the arrow A13, for example, to be at an oblique arrangement relative to the containers CA1, CA2, CA3, CB1, CB2, CB3, and the top panel 259 can be folded at the fold line 261a in the direction of the arrow A13 into at least partial face-to-face contact with at least a portion of the attachment panels 431a, 431b. Similarly, the back side panel 255b can be folded upwardly at the fold line 257b in the direction of the arrow A14 into an oblique arrangement with the containers CA1, CA2, CA3, CB1, CB2, CB3, and the attachment flap 277 can be folded at the fold line 261b in the direction of the arrow A14 into at least partial face-to-face contact with the top panel 259 and/or the attachment panel 431b.

[0092] Accordingly, containers can be engaged by the respective attachment panels 431a, 431b and can extend below the respective container retention portions 435a, 435b in the assembled carrier 405/package 410. In such an arrangement, containers CA1, CA2, CA3 extend below the container retention portion 435a in the front portion 406 of the carrier 405, and containers CB1, CB2, CB3 extend below the container retention portion 435b in the back portion 408 of the carrier 405, with the top panel 259 and the attachment flap 277 overlying respective portions of the respective container retention portions 435a, 435b. Further, the front central panel 225a and the back central panel 225b are positioned between and attached to respective ones of the containers CA1, CA2, CA3, CB1, CB2, CB3.

- [0093] A user can grasp the carrier 405 by inserting one or more fingers through the top handle opening 463 to grasp a portion of the carrier 405, for example, an underside of the top panel 259 and/or the attachment panels 431a, 431b. The alignment of the handle openings 430a, 430b below the handle feature in the top panel 259, e.g., the top handle opening 463, in the erected carrier 405 provides a space through which the user's fingers can extend below the top panel 259 into an interior portion of the carrier 405.
- [0094] The configuration of the carrier 405/package 410 provides a compact and robust holding and carrying structure for the containers CA1, CA2, CA3, CB1, CB2, CB3, with the advantages described above with respect to the carrier 205/package 210 and the carrier 305/package 310.
- [0095] Fig. 16 is a plan view of the exterior side 501 of a blank, generally indicated at 503, used to form a carrier 505 (Fig. 21) for containing one or more containers according to a fourth exemplary embodiment of the disclosure. The blank 503 and the carrier 505 formed therefrom can have one or more substantially similar features to the blanks 203, 303, 403 and the carriers 205, 305, 405 described above, and like or similar components are referenced with like or similar reference numbers.
- [0096] As shown, the blank 503 includes a front portion 507 and a back portion 509 and includes container retention features such that respective container retention portions 535a, 535b are configured to engage and support three containers in the front portion 506 of the carrier 505 and three containers in the back portion 508 of the carrier 505 formed from the blank 503. The central panels 225a, 225b of the blank 503 are each partitioned by respective pairs of openings 430a, 430b that extend from each respective central panel 225a, 225b into the respective attachment panels 531a, 531b.
- [0097] As shown, the respective container retention portions 535a, 535b of the respective attachment panels 531a, 531b include the respective lateral fold lines 237a, 239a and 237b, 239b, interrupted by the respective cuts 241a, 243a, 245a and 241b, 243b, 245b that can form a plurality of flexible edges in the respective container retention portions. As shown, endpoints of the respective cuts 241a, 241a are connected by additional respective cuts 546a, 546b to form respective container retention openings 550a, 550b therebetween. In this regard, the container retention portions 543a, 543b are arranged to receive a portion of respective containers CA1, CA2, CA3 and CB1, CB2, CB3, e.g., a rim or top portion T thereof, through portions of the respective container retention openings 550a, 550b. As also shown, an interior marginal portion 536a of the attachment panel 531a is defined between the fold lines 237a, 233a, and an exterior marginal portion 538a of the attachment panel 531a is defined between the fold line 239a and a lateral fold line 257a adjacent the attachment panel 531a.

[0098] Further, the container retention features include a plurality of end flaps foldably connected to the respective container retention portions 535a, 535b, including first end flaps 552a, 552b foldably connected to laterally-opposed sides of the respective container retention portions 535a, 535b at respective oblique fold lines 554a, 554b, respective second end flaps 560a, 560b foldably connected to laterally-opposed sides of the respective container retention portions 535a, 535b at respective oblique fold lines 562a, 562b, and respective third end flaps 556a, 556b foldably connected to laterally-opposed sides of the respective container retention portions 535a, 535b at respective longitudinal fold lines 558a, 558b. The respective end flaps 552a, 556a and 552b, 556b are foldably connected to one another at respective portions of the respective fold lines 239a, 239b and the respective end flaps 556a, 560a and 556b, 560b are foldably connected to one another at respective portions of the respective fold lines 237a, 237b.

[0099] As shown, the top panel 259 of the blank 503 includes handle features that include a pair of handle flaps 563 (broadly, respective “first handle feature” and “second handle feature”) that are foldably connected to the top panel 259 at respective longitudinal fold lines 565 and that are defined by respective cuts 567 that extend from one endpoint of the respective fold lines 565 to the other respective endpoint. Handle features of the carrier 505 include the handle features in the top panel 259, and can also include the handle openings 430a, 430b. The carrier 405 can have a different arrangement of handle features, or can be devoid of handle features, without departing from the disclosure.

[00100] As also shown, glue G can be applied to one or more portions of the central panels 225a, 225b, e.g., across the respective surface features 229a, 229b. While the glue G is illustrated on the exterior surface 501 of the blank 503 in Fig. 16 for clarity of illustration and to indicate positioning relative to other features of the blank 503, it will be understood that the glue G is applied to at least the interior surface of the central panels 225a, 225b. In one embodiment, glue G can be applied to both the interior surface and the exterior surface of the central panels 225a, 225b.

[00101] Referring additionally to Figs. 17-23, formation of the carrier 505 from the blank 503 and an associated package 510 that includes the containers CA1, CA2, CA3, CB1, CB2, CB3 is illustrated according to one exemplary embodiment of the disclosure. It will be understood that the carrier 505 can be formed in a similar manner to that of the carriers 205, 305, 405 described above, and is provided with at least similar properties and advantages.

[00102] As shown in Fig. 17 (in which the glue G is omitted for clarity of illustration), the exterior surface 501 of the blank 503 can be placed atop the containers CA1, CA2, CB1, CB2, CB3 such that the container retention portion 535a of the front attachment panel 531a overlies the containers CA1, CA2, CA3 and such that the container retention portion 535b of the back attachment panel 531b overlies

the containers CB1, CB2, CB3. Further downward positioning of the attachment panels 531a, 531b over the plurality of containers CA1, CA2, CA3, CB1, CB2, CB3 can activate the respective container retention portions 535a, 535b to engage respective containers. For example, as the front attachment panel 531a is lowered or urged downwardly onto the containers CA1, CA2, CA3, an upper or top portion T of the respective containers CA1, CA2, CA3 can at least partially protrude through the respective openings 550a formed by the respective cuts 241a, 546a. Such engagement of the corresponding portions of the back attachment panel 531b can occur as the back attachment panel 531b is lowered or urged downwardly onto the containers CB1, CB2, CB3. The marginal portions 536a, 538a of the attachment panel 531a can fold at least partially downwardly at the respective fold lines 237a, 239a in such a configuration, and, similarly, the marginal portions 536b, 538b of the attachment panel 531b can fold at least partially downwardly at the respective fold lines 237b, 239b.

[00103] In this regard, portions of the container retention portion 535a, e.g., portions of the attachment panel 531a adjacent the respective openings 550a, can engage one or more portions of the respective containers CA1, CA2, CA3, for example, an edge presented by a rim or top portion T of the respective containers CA1, CA2, CA3. It will be understood that other portions of the front attachment panel 531a can form a portion of the container retention portion 535a, for example, a portion of the front attachment panel 531a disposed between and/or adjacent the respective cuts 243a, 245a, which can engage an edge presented by the rim or top portion T of the respective containers CA1, CA2, CA3 as described above. The back attachment panel 531b and corresponding container retention portion 535b can engage the containers CB1, CB2, CB3 in a similar manner as described above with respect to the engagement of the front attachment panel 531a and container retention portion 535a with respect to the containers CA1, CA2, CA3.

[00104] The front central panel 225a and the back central panel 225b can be folded at the fold line 212 and brought into at least partial face-to-face contact in the direction of the respective arrows A15, A16, and such that the respective glue openings 227a, 227b are in general alignment and positioned so as to be laterally aligned but longitudinally offset. In this regard, the central panels 225a, 225b are arranged such that a portion of the front central panel 225a overlaps each of the glue openings 227b and a portion of the back central panel 225b overlaps each of the glue openings 227a to provide communication between the central panels 225a, 225b and respective surfaces upon which the respective containers CA1, CA2, CA3 and CB1, CB2, CB3 can be adhered or otherwise attached, as described further herein.

[00105] As shown in Fig. 19, in which the container CA2 is removed for clarity of illustration, glue G can be provided in alignment with the glue openings 227a to adhere the containers CA1, CA2, CA3 to respective exposed portions of the central panel 225b through the respective glue openings 227a, and

the glue G can be provided in alignment with the glue openings 227b to adhere the containers CB1, CB2, CB3 to respective exposed portions of the central panel 225a through the respective glue openings 227b. In one embodiment, the glue G can cover at least a portion of the surface features 229a, 229b such that one or more of the surface features 229a, 229b presents additional surfaces for adhesion and/or spacing between the front portion 506 and the back portion 508 of the carrier 505.

[00106] As described above, the adhesion of the containers of the front portion 506 of the carrier 505 to respective surfaces of the back central panel 225b exposed through the glue openings 227a, and the adhesion of the containers of the back portion 508 of the carrier 505 to respective surfaces of the front central panel 225a exposed through the glue openings 227b can provide compression between the central panels 225a, 225b and stability to the carrier 505. The containers can be attached to the respective central panels 225a, 225b in a different configuration as described above, e.g., a configuration in which the containers are not engaged by a container retention portion or a configuration in which a fewer number of or no glue openings are provided.

[00107] Additionally, and as shown, the respective end flaps 556a, 556b can be folded upwardly at the respective fold lines 558a, 558b in the direction of the arrows A17, A18 into overlapping and/or face-to-face contact with the respective container retention portions 535a, 535b of the respective attachment panels 531a, 531b. Such movement of the respective end flaps 556a, 556b urges the respective end flaps 552a, 552b to fold downwardly away from the respective attachment panels 531a, 531b at the respective fold lines 554a, 554b and to fold inwardly toward the respective end flaps 556a, 556b at the respective fold lines 239a, 239b in the direction of the respective arrows A19, A20 and causes the respective end flaps 560a, 560b to fold downwardly away from the respective attachment panels 531a, 531b at the respective fold lines 562a, 562b and to fold inwardly toward the respective end flaps 556a, 556b at the respective fold lines 237a, 237b in the direction of the respective arrows A21, A22. In such an arrangement, the respective end flaps 552a, 552b, 560a, 560b overlie longitudinally exterior-facing portions of the respective containers CA1, CA3, CB1, CB3.

[00108] Still referring to Figs. 17-23, the front side panel 255a can be folded upwardly at the fold line 257a in the direction of the arrow A23, for example, to be at an oblique arrangement relative to the containers CA1, CA2, CA3, CB1, CB2, CB3, and the top panel 259 can be folded at the fold line 261a in the direction of the arrow A23 into at least partial face-to-face contact with at least a portion of the attachment panels 531a, 531b. Similarly, the back side panel 255b can be folded upwardly at the fold line 257b in the direction of the arrow A24 into an oblique arrangement with the containers CA1, CA2, CA3, CB1, CB2, CB3, and the attachment flap 277 can be folded at the fold line 261b in the direction

of the arrow A24 into at least partial face-to-face contact with the top panel 259 and/or the attachment panel 531b.

[00109] Accordingly, containers can be engaged by the respective attachment panels 531a, 531b and can extend below the respective container retention portions 535a, 535b in the assembled carrier 505/package 510. In such an arrangement, containers CA1, CA2, CA3 extend below the container retention portion 535a in the front portion 506 of the carrier 505, and containers CB1, CB2, CB3 extend below the container retention portion 535b in the back portion 508 of the carrier 505, with the top panel 259 and the attachment flap 277 overlying respective portions of the respective container retention portions 535a, 535b. In such an arrangement, respective end flaps 552a, 556a, 560a, 552b, 556b, 560b are positioned to engage outward-facing portions of respective containers, for example, to provide enhanced engagement between the carrier 505 and the containers CA1, CA2, CA3, CB1, CB2, CB3. Further, the front central panel 225a and the back central panel 225b are positioned between and attached to respective ones of the containers CA1, CA2, CA3, CB1, CB2, CB3.

[00110] The carrier 505 can be grasped by separating one or both of the handle flaps 563 at the respective cuts 567 and folding the respective handle flaps 563 downwardly at the respective fold lines 565 toward the respective openings 430a, 430b such that a user can insert one or more fingers therethrough to grasp a portion of the carrier 505, for example, an underside of the top panel 259 and/or the attachment panels 531a, 531b. The alignment of the handle openings 430a, 430b below the handle flaps 563 in the erected carrier 505 provides a space through which the user's fingers can extend below the top panel 259 into an interior portion of the carrier 505.

[00111] The configuration of the carrier 505/package 510 provides a compact and robust holding and carrying structure for the containers CA1, CA2, CA3, CB1, CB2, CB3, with the advantages described above with respect to the carriers 205, 305, 405.

[00112] Fig. 24 shows a plan view of an exterior side 601 of a blank 603 used to form a carrier 605 (Fig. 29) in accordance with a fifth exemplary embodiment of the disclosure. The blank 603 and carrier 605 can have one or more features that are substantially similar to those described above with regard to the blanks 203, 303, 403, 503 and carriers 205, 305, 405, 505, and like or similar features are identified with like or similar reference numerals.

[00113] The carrier 605 can be sized to contain or support six containers, with three containers CA1, CA2, CA3 being attached to a front portion 606 of the carrier 605 and three containers CB1, CB2, CB3 being attached to a back portion 608 of the carrier 605. In the illustrated embodiment, the containers CA1, CA2, CA3, CB1, CB2, CB3 can be beverage cans, or could be any other suitable type and size of

container without departing from the disclosure. The carrier 605 can be sized and shaped to hold more or less than six containers. In one embodiment, the front portion 606 and the back portion 608 of the carrier 605 each have three containers, and in other embodiments, the front portion 606 and the back portion 608 of the carrier 605 can carry more or less than three containers without departing from the disclosure. The carrier 605 can be provided together with one or more containers as a package 610 (Fig. 29).

[00114] As shown in Figs. 24, 24A, and 24B, the blank 603 has a longitudinal axis L1 and a lateral axis L2. The blank 603 has a front portion 607 for forming the front portion 606 of the carrier 605, and a back portion 609 for forming the back portion 608 of the carrier 605. The front portion 607 and the back portion 609 of the blank 603 are foldably connected at a lateral fold line 612 that forms a lateral centerline CL of the blank 603, as shown. As discussed further below, the blank 603 is at least partially formed into the carrier 605 by folding the blank 603 at the fold line 612 along the centerline CL so that the front portion 607 and the back portion 609 of the blank 603 are overlapped in at least partial face-to-face contact.

[00115] In the illustrated embodiment, the front portion 607 of the blank 603 comprises a front central panel 625a having a front row RF of laterally spaced adhesive or glue openings 627a. The top edges of the respective glue openings 627a of the row RF are spaced a longitudinal distance D5 apart from the fold line 612.

[00116] A front container retention panel or front attachment panel 631a is foldably connected to the front central panel 625a at a lateral fold line 633a, and includes a container retention portion 635a that is at least partially defined between a pair of longitudinally-spaced lateral fold lines 637a, 639a (broadly, respective “second fold line”) that are each interrupted by respective pairs of longitudinally-spaced cuts 641a that can each include one or more curved and/or angled portions. As shown, the longitudinally-spaced cuts 641a define container retention tabs 648a that extend outwardly from the container retention portion 635a. As also shown, respective cuts 643a can extend outwardly from one or more of the respective cuts 641a to define a plurality of reconfigurable edges of the front attachment panel 631a that face the respective container retention tabs 648a.

[00117] As shown, an interior marginal portion 636a of the attachment panel 631a is defined between the fold lines 637a, 633a, and an exterior marginal portion 638a of the attachment panel 631a is defined between the fold line 639a and a lateral fold line 671a (broadly, “first fold line”).

- [00118] The blank 603 can include handle features including a pair of handle openings 630a that interrupt the fold line 633a and that extend from a portion of the front central panel 625a into a portion of the front attachment panel 631a.
- [00119] The blank 603 additionally includes a bevel or front side panel 669a that is foldably connected to the front attachment panel 631a at the lateral fold line 671a, and a top panel 673 that is foldably connected to the front side panel 669a at a lateral fold line 675a (broadly, “second fold line”).
- [00120] As also shown, the top panel 673 can include further handle features for cooperating with the handle features described above. A pair of laterally spaced handle flaps 674 can be foldably connected to the top panel 673 at respective longitudinal fold lines 676 and can be defined by respective curved cuts 678 extending from one end point of the respective fold lines 676 to the other endpoint of the respective fold lines 676. Each handle flap 674, as shown, can include a central portion 670 and a pair of reinforcement portions 672 foldably connected to the central portion 670 at a respective line of weakening 668.
- [00121] With continued reference to Figs. 24, 24A, and 24B, the blank 603/carrier 605 formed therefrom can be configured to stiffen/inhibit relative movement of portions of the blank 603/carrier 605 when in use. As shown, a series of laterally-spaced reinforcement features/reinforcement panels 677a can be positioned interrupting the fold line 675a. Each reinforcement feature/panel 677a, as shown, can be a region of the blank 603/carrier 605 between the top panel 673 and the attachment panel 631a and that is defined by lines of weakening 679a extending between endpoints of segments of the fold line 675a.
- [00122] The lines of weakening 679a of each reinforcement feature/panel 677a, as shown, can include a laterally outer curved segment 681a, a laterally inner curved segment 683a, and generally oblique segments 682a, 684a extending from respective endpoints of the curved segment 681a to respective endpoints of the curved segment 683a. The outer curved segment 681a can have a radius of curvature that is larger than a radius of curvature of the inner curved segment 683a such that each reinforcement feature/panel 677a can have a generally rhomboid/diamond/triangular/shield shape. It will be understood that one or more of the lines of weakening 679a/reinforcement features/panels 677a can have one or more different features, e.g., curved/angled/straight longitudinal and/or lateral portions, without departing from the disclosure. It will be understood that a different number and/or arrangement of the reinforcement features/panels 677a can be provided without departing from the disclosure. For example, in one embodiment, the lines of weakening 679a can be devoid of the inner curved segment 683a such that the segments 682a, 684a intersect the fold line 671a.

[00123] Any of the panels, flaps, fold lines, cuts, or other features could be otherwise shaped, arranged, and/or omitted from the blank 603 without departing from the disclosure. The blank 603 could be sized and/or shaped to accommodate more or less than eight containers without departing from this disclosure.

[00124] In the illustrated embodiment, the back portion 609 of the blank 603 includes a back central panel 625b, the back container retention panel or back attachment panel 631b, and the back bevel or back side panel 669b having associated features that are generally a mirror-image of the corresponding panels and flaps of the front portion 607 of the blank 603. Corresponding components (e.g., panels, flaps, fold lines, cuts, etc.) have been designated by corresponding reference numbers that differ by the "a" or "b" suffix, with the "a" components corresponding to the front portion 607 of the blank 603 and the "b" components corresponding to the back portion 609 of the blank 603. The back portion 609 of the blank 603 includes a back top panel or top attachment flap 685 foldably connected to the back side panel 669b at a lateral fold line 675b.

[00125] As shown, respective glue openings 627b of a back row RB of glue openings 627b have respective top edges spaced apart a longitudinal distance D6 from the fold line 612. In this regard, the blank 603 is provided with a front row RF of laterally-spaced front glue openings 627a that are spaced respective longitudinal distances D5 from the centerline CL, and a back row RB of laterally-spaced back glue openings 627b that are spaced respective longitudinal distances D6 from the centerline CL. The glue openings 627a, 627b have a longitudinally staggered arrangement such that $D6 > D5$. Upon formation of the carrier 605 from the blank 603, the longitudinal centerline CL/fold line 612 can form a bottom edge of the central panels 625a, 625b.

[00126] As described herein, the arrangement of the glue openings 627a, 627b is such that, upon erection of the carrier 605, the glue openings 627a, 627b provide access to a respective plurality of surfaces of the respective central panels 625b, 625a upon which the respective containers CA1, CA2, CA3, CB1, CB2, CB3 can be attached to enhance retention and support of the containers CA1, CA2, CA3, CB1, CB2, CB3 by the carrier 605.

[00127] Any of the panels, flaps, fold lines, cuts, or other features could be otherwise shaped, arranged, and/or omitted from the blank 603 without departing from the disclosure. The blank 603 could be sized and/or shaped to accommodate more or less than four containers without departing from this disclosure.

[00128] Referring additionally to Figs. 25-29, according to one exemplary embodiment of the disclosure, the carrier 605 can be formed by placing the exterior surface 601 of the blank 603 atop the containers CA1, CA2, CA3, CB1, CB2, CB3 such that the container retention portion 635a of the front attachment panel 631a overlies the containers CA1, CA2, CA3 and such that the container retention

portion 635b of the back attachment panel 631b overlies the containers CB1, CB2, CB3. Further downward positioning of the attachment panels 631a, 631b over the plurality of containers CA1, CA2, CA3, CB1, CB2, CB3 can activate the respective container retention portions 635a, 635b to engage respective containers.

[00129] For example, as the front attachment panel 631a is lowered or urged downwardly onto the containers CA1, CA2, CA3, the container retention portion 635a can at least partially separate from the remainder of the front attachment panel 631a at the cuts 641a. In such an arrangement, upper or top portions T of the respective containers CA1, CA2, CA3 can extend at least partially through respective openings formed by the respective cuts 641a such that the container retention tabs 648a can engage, for example, a recessed portion of a rim or other top structure of the respective container CA1, CA2, CA3, and such that a plurality of reconfigurable edges of the marginal portions 636a, 638a can engage, for example, a rolled rim edge or other top structure of the respective container CA1, CA2, CA3.

[00130] Such reconfiguration of the corresponding portions of the back attachment panel 631b can occur as the back attachment panel 631b is lowered or urged downwardly onto the containers CB1, CB2, CB3. During the above-described engagement of the respective container retention portions 635a, 635b with the respective containers, the marginal portions 636a, 638a of the attachment panel 631a can fold at least partially downwardly at the respective fold lines 637a, 639a in such a configuration, and, similarly, the marginal portions 636b, 638b of the attachment panel 631b can fold at least partially downwardly at the respective fold lines 637b, 639b.

[00131] Thereafter, the front central panel 625a and the back central panel 625b can be folded at the fold line 612 such that the front central panel 625a and the back central panel 625b are brought into at least partial face-to-face contact to be positioned between respective adjacent containers and such that the respective glue openings 627a, 627b are positioned so as to be laterally aligned but longitudinally offset due to the different relative spacing of the rows RF of the front glue openings 627a and the row RB of the back glue openings 627b away from the fold line 612 as described above.

[00132] In this regard, the central panels 625a, 625b are arranged such that a portion of the front central panel 625a overlaps each of the glue openings 627b and a portion of the back central panel 625b overlaps each of the glue openings 627a to provide communication between the central panels 625a, 625b and respective surfaces upon which the respective containers CA1, CA2, CA3, CB1, CB2, CB3 can be adhered or otherwise attached, as described further herein. Such rearrangement of the central panels 625a, 625b can also cause the respective central panels 625a, 625b to be folded downwardly relative to the respective attachment panels 631a, 631b at the respective fold lines 633a, 633b.

[00133] It will be understood that an adhesive glue, e.g., glue G (Fig. 24) can be provided to adhere the containers CA1, CA2, CA3 to respective portions of the central panel 625b exposed through the respective glue openings 627a, and the glue can be provided to adhere the containers CB1, CB2, CB3 to respective portions of the central panel 625a exposed through the respective glue openings 627b. The arrangement of multiple rows of respective glue openings 627a, 627b provides multiple points of attachment of each respective container to the respective opposite central panel 625a, 625b such that each container is provided with a robust attachment to a respective central panel 625a, 625b. The attachment of the containers CA1, CA2, CA3, and containers CB1, CB2, CB3 to the respective central panel 625a, 625b can provide retention and support of the respective containers, e.g., such that the containers do not detach from the carrier 605 under their own weight, in addition to or alternative to the container retention and support provided by the respective container retention portions 635a, 635b. For example, in one embodiment, one or more of the containers CA1, CA2, CA3, CB1, CB2, CB3 can be attached to a respective central panel 625a, 625b with glue G, without additional retention and support provided by a container retention portion as described above.

[00134] The glue described herein can be, for example, a hot melt adhesive, a high tack glue, an epoxy, a polymeric cement, etc., or combinations thereof. The glue can have a different arrangement without departing from the disclosure. In another embodiment, the glue G can have a foam or foamed configuration, e.g., such that pockets of fluids such as gas are interspersed with solid, semi-solid, and/or liquid components of adhesive. In this regard, the glue G can be injected/infused with a fluid, e.g., gaseous, component that influences the glue G to expand from an originally-defined volume, over a change in time, to occupy a larger volume. In one embodiment, the glue G can comprise about 50% solid/semi-solid/liquid adhesive and about 50% gaseous components.

[00135] In other embodiments, the glue G can comprise a different ratio of adhesive to gaseous components, for example, about 10% adhesive/about 90% gaseous components, about 20% adhesive/about 80% gaseous components, about 30% adhesive/about 70% gaseous components, about 40% adhesive/about 60% gaseous components, about 60% adhesive/about 40% gaseous components, about 70% adhesive/about 30% gaseous components, about 80% adhesive/about 20% gaseous components, about 90% adhesive/about 10% gaseous components, or other integer or non-integer percentage ratios therebetween. The glue G can be any suitable adhesive without departing from the disclosure.

[00136] Such enhanced attachment of the respective containers to the respective central panels 625a, 625b with the glue can also provide enhanced integrity to the carrier 605, e.g., by providing opposing adhesive forces on the respective central panels 625a, 625b such that the central panels 625a, 625b are

compressed therebetween. For example, in one embodiment, as the carrier 605 is lifted, the containers CA1, CA2, CA3 can at least partially pull the portions of the back central panel 625b to which they are attached through the respective glue openings 627a toward the front central panel 625a under the at least partial weight of the containers CA1, CA2, CA3. Respective portions of the front central panel 625a can be pulled toward the back central panel 625b through the respective glue openings 627b by the containers CB1, CB2, CB3 in a similar manner.

[00137] Still referring to Figs. 25-29, the front side panel 669a can be folded upwardly at the fold line 671a and the top panel 673 can be folded at the fold line 675a into at least partial face-to-face contact with at least a portion of the attachment panels 631a, 631b. Similarly, the back side panel 669b can be folded upwardly at the fold line 671b and the attachment flap 685 can be folded at the fold line 675b into at least partial face-to-face contact with the top panel 673 and/or the attachment panel 431b. Such an arrangement can be maintained with an adhesive such as glue.

[00138] In embodiments in which the attachment flap 685 at least partially overlaps the top panel 673, such an arrangement can facilitate alignment of the edges thereof and/or printed graphics thereon so as to obviate further steps of manipulating the top panel 673 and the attachment flap 685 relative to one another, for example, as compared to an arrangement in which the attachment flap 685 and top panel 673 are positioned in an abutting relation. Such an arrangement can also maintain clean lines and edges of the carrier 605/package 610 and/or minimize the exposure of interior portions of the carrier 605/package 610 to a user, e.g., an interior surface of the blank 603.

[00139] Upon folding of the top panel 673 at the fold line 675a, the laterally curved outer segments 681a of the respective reinforcement features/panels 677a can engage, e.g., contour, abut, etc., respective rolled rim edges or other top structures of the respective containers CA1, CA2, CA3. In this regard, the laterally curved outer segments 681a of the respective lines of weakening 679a can provide points at which the top panel 673 can pivot, e.g., in a lever action, about the rims of the respective containers CA1, CA2, CA3 to facilitate folding of the top panel 673 at the fold line 675a.

[00140] Furthermore, the interruption of the fold line 675a provided by the presence of the laterally curved outer segments 681a can reduce the amount of time and/or force required to fold the top panel 673 in the manner described above. Accordingly, machine/forming operations can be streamlined. In one embodiment, one or more of the lines of weakening/fold lines associated with the blank 603/carrier 605 can be reduced in profile, e.g., length, width, depth, continuity, etc., as compared to, for example, a carrier/package devoid of the reinforcement features/panels 677a.

[00141] Similarly, the folding of the attachment flap 685 at the fold line 675b can be facilitated by the presence of the laterally curved outer segments 681b of the respective reinforcement features/panels 677b and the engagement thereof with the respective rims of the containers CB1, CB2, CB3 as described above with regard to the folding of the top panel 673.

[00142] Furthermore, the reinforcement features/panels 677a, 677b are presented in an outward-facing arrangement relative to the attachment panels 631a, 631b, top panel 675, and attachment flap 685 so as to form a generally upright/vertical structure that further minimizes/resists bending, buckling, flexion, torsion, etc. of the carrier 605/package 610 relative to a plane defined by the top panel 675/attachment flap 685 and/or the attachment panels 631a, 631b, e.g., such that the carrier 605/package 610 minimizes/resists such forces/movement along both the longitudinal axis L1 and the lateral axis L2.

[00143] In order to engage the carrier 605/package 610, the respective handle flaps 674 can be at least partially separated from the top panel 673 at the respective cuts 678, and folded or flexed downwardly at the respective fold lines 676 into an interior portion of the carrier 605/package 610 through the respective handle openings 630a, 630b. The handle openings 630a, 630b provide clearance for the handle flaps 674 to extend downwardly in such an arrangement. In one embodiment, one or both of the handle flaps 674 can be provided with a reconfigurable arrangement, for example, so as to contour or angle against one or more of the respective containers CA1, CA2, CA3, CB1, CB2, CB3, e.g., such that at least a central portion of the respective handle flaps 474 can be positioned between adjacent containers.

[00144] In one embodiment, the reinforcement portions 672 of the respective handle flaps 674 can at least partially wrap around/fold at the respective lines of weakening 677 or surround a consumer's finger, for example, to minimize or prevent contact of the consumer's finger with edges or corners of the carrier 605/package 610 and/or the respective containers.

[00145] With additional reference to Fig. 30, upon formation of the package 610/carrier 605, a respective container CA1, CA2, CA3, CB1, CB2, CB3 can be removed from the carrier 605 by disengaging the container from a respective attachment panel 631a, 631b, for example, by withdrawing the top portion T of a respective container through an opening formed by a respective cut 641a, 641b along the respective attachment panel 631a, 631b, and peeling the respective container away from the respective central panel 625a, 625b. Peeling or pulling the containers CA1, CA2, CA3, CB1, CB2, CB3 away from a respective central panel 625a, 625b can involve pulling the respective container with a force sufficient to overcome the adhesive bond of the respective container and the respective central panel 625a, 625b provided by the glue G. In one embodiment, the glue can be selected so as to remain

on a respective central panel 625a, 625b, e.g., such that substantially little or no glue remains on the container as it is removed. One or more of the containers CA1, CA2, CA3, CB1, CB2, CB3, in one embodiment, can be reattached to a respective central panel 625a, 625b following therefrom by pressing the container against a respective region of glue.

[00146] The carrier 605/package 610 can have a different configuration without departing from the disclosure, and it will be understood that any of the blanks, carriers, and packages described herein can be provided in different configurations without departing from the disclosure.

[00147] It will be understood that the blanks and carriers described herein can be provided in different configurations without departing from the disclosure.

[00148] In general, the blank may be constructed from paperboard having a caliper so that it is heavier and more rigid than ordinary paper. The blank can also be constructed of other materials, such as cardboard, or any other material having properties suitable for enabling the carrier to function at least generally as described above. The blank can be coated with, for example, a clay coating. The clay coating may then be printed over with product, advertising, and other information or images. The blanks may then be coated with a varnish to protect information printed on the blanks. The blanks may also be coated with, for example, a moisture barrier layer, on either or both sides of the blanks. The blanks can also be laminated to or coated with one or more sheet-like materials at selected panels or panel sections.

[00149] As an example, a tear line can include: a slit that extends partially into the material along the desired line of weakness, and/or a series of spaced apart slits that extend partially into and/or completely through the material along the desired line of weakness, or various combinations of these features. As a more specific example, one type tear line is in the form of a series of spaced apart slits that extend completely through the material, with adjacent slits being spaced apart slightly so that a nick (e.g., a small somewhat bridging-like piece of the material) is defined between the adjacent slits for typically temporarily connecting the material across the tear line. The nicks are broken during tearing along the tear line. The nicks typically are a relatively small percentage of the tear line, and alternatively the nicks can be omitted from or torn in a tear line such that the tear line is a continuous cut line. That is, it is within the scope of the present disclosure for each of the tear lines to be replaced with a continuous slit, or the like. For example, a cut line can be a continuous slit or could be wider than a slit without departing from the present disclosure.

[00150] In accordance with the exemplary embodiments, a fold line can be any substantially linear, although not necessarily straight, form of weakening that facilitates folding therealong. More specifically, but not for the purpose of narrowing the scope of the present disclosure, fold lines include: a score line, such as lines formed with a blunt scoring knife, or the like, which creates a crushed or depressed portion in the material along the desired line of weakness; a cut that extends partially into a material along the desired line of weakness, and/or a series of cuts that extend partially into and/or completely through the material along the desired line of weakness; and various combinations of these features. In situations where cutting is used to create a fold line, typically the cutting will not be overly extensive in a manner that might cause a reasonable user to incorrectly consider the fold line to be a tear line.

[00151] The above embodiments may be described as having one or more panels adhered together by glue during erection of the carrier embodiments. The term “glue” is intended to encompass all manner of adhesives commonly used to secure carrier panels in place.

[00152] The foregoing description of the disclosure illustrates and describes various exemplary embodiments. Various additions, modifications, changes, etc., could be made to the exemplary embodiments without departing from the spirit and scope of the disclosure. It is intended that all matter contained in the above description or shown in the accompanying drawings shall be interpreted as illustrative and not in a limiting sense. Additionally, the disclosure shows and describes only selected embodiments of the disclosure, but the disclosure is capable of use in various other combinations, modifications, and environments and is capable of changes or modifications within the scope of the inventive concept as expressed herein, commensurate with the above teachings, and/or within the skill or knowledge of the relevant art. Furthermore, certain features and characteristics of each embodiment may be selectively interchanged and applied to other illustrated and non-illustrated embodiments of the disclosure.

WHAT IS CLAIMED IS:

1. A carrier for holding a plurality of containers, the carrier comprising:

a plurality of panels comprising at least one central panel, at least one attachment panel, at least one side panel, and at least one top panel, the at least one attachment panel configured to receive a portion of one or more containers of the plurality of containers; and

at least one reinforcement panel positioned between the at least one attachment panel and the at least one top panel,

the at least one central panel is for being positioned between and attached to adjacent containers of the plurality of containers.

2. The carrier of claim 1, wherein the at least one reinforcement panel is generally upright relative to the at least one central panel.

3. The carrier of claim 2, wherein the at least one reinforcement panel is formed by a line of weakening.

4. The carrier of claim 3, wherein the at least one reinforcement panel is at least partially formed in the at least one side panel.

5. The carrier of claim 4, wherein the line of weakening includes at least one curved segment intersecting a pair of oblique segments.

6. The carrier of claim 5, wherein the at least one side panel is foldably connected to the at least one attachment panel at a first fold line, and the at least one top panel is foldably connected to the at least one side panel at a second fold line, the at least one reinforcement panel interrupts at least one of the first fold line and the second fold line.

7. The carrier of claim 3, wherein the at least one central panel is a front central panel, the at least one attachment panel is a front attachment panel, the at least one side panel is a front side panel, the at least one top panel is a front top panel, and the plurality of panels further comprises a back central panel in at least partial face-to-face contact with the front central panel and for being positioned between and attached to adjacent containers of the plurality of containers, a back attachment panel, a back side panel, and a back top panel, the back attachment panel configured receive a portion of one or more containers of the plurality of containers.

8. The carrier of claim 7, wherein the at least one reinforcement panel is an at least one front reinforcement panel positioned between the front attachment panel and the front top panel, and the carrier further comprises at least one back reinforcement panel positioned between the back attachment panel and the back top panel.

9. The carrier of claim 2, wherein the at least one central panel is for being adhered to adjacent containers of the plurality of containers.

10. The carrier of claim 2, wherein the at least one central panel is a front central panel, the plurality of panels further comprises a back central panel in at least partial face-to-face contact with the front central panel, and at least one of the front central panel and the back central panel comprises a respective at least one opening in communication with the respective other of the front central panel and the back central panel.

11. The carrier of claim 10, wherein each of the front central panel and the back central panel comprises a respective at least one opening in communication with the respective other of the front central panel and the back central panel.

12. The carrier of claim 11, wherein the at least one opening in the front central panel is offset from the at least one opening in the back central panel.

13. The carrier of claim 12, wherein a portion of the back central panel is exposed through the at least one opening in the front central panel and a portion of the front central panel is exposed through the at least one opening in the back central panel.

14. The carrier of claim 12, wherein the front central panel is foldably connected to the back central panel at a lateral fold line, the at least one opening in the front central panel is spaced a first longitudinal distance from the fold line, the at least one opening in the back central panel is spaced a second longitudinal distance from the fold line, the first longitudinal distance is greater than the second longitudinal distance.

15. The carrier of claim 12, wherein the at least one attachment panel is a front attachment panel, the at least one side panel is a front side panel, the at least one top panel is a front top panel, and the plurality of panels further comprises a back attachment panel, a back side panel, and a back top panel, the back attachment panel configured receive a portion of one or more containers of the plurality of containers.

16. The carrier of claim 2, wherein the at least one top panel comprises at least one handle feature and the at least one central panel comprises at least a portion of at least one handle opening, the at least one handle feature of the top panel is aligned with the at least a portion of the at least one handle opening.

17. A blank for forming a carrier for holding a plurality of containers, the blank comprising:

a plurality of panels comprising at least one central panel, at least one attachment panel, at least one side panel, and at least one top panel, the at least one attachment panel configured to receive a portion of one or more containers of the plurality of containers when the carrier is formed from the blank; and

at least one reinforcement panel positioned between the at least one attachment panel and the at least one top panel,

the at least one central panel is for being positioned between and attached to adjacent containers of the plurality of containers when the carrier is formed from the blank.

18. The blank of claim 17, wherein the at least one reinforcement panel is formed by a line of weakening.

19. The blank of claim 18, wherein the at least one reinforcement panel is at least partially formed in the at least one side panel.

20. The blank of claim 19, wherein the line of weakening includes at least one curved segment intersecting a pair of oblique segments.

21. The blank of claim 20, wherein the at least one side panel is foldably connected to the at least one attachment panel at a first fold line, and the at least one top panel is foldably connected to the at least one side panel at a second fold line, the at least one reinforcement panel interrupts at least one of the first fold line and the second fold line.

22. The blank of claim 18, wherein the at least one central panel is a front central panel, the at least one attachment panel is a front attachment panel, the at least one side panel is a front side panel, the at least one top panel is a front top panel, and the plurality of panels further comprises a back central panel, a back attachment panel, a back side panel, and a back top panel, the back attachment panel configured receive a portion of one or more containers of the plurality of containers when the carrier is formed from the blank.

23. The blank of claim 22, wherein the at least one reinforcement panel is an at least one front reinforcement panel positioned between the front attachment panel and the front top panel, and the carrier further comprises at least one back reinforcement panel positioned between the back attachment panel and the back top panel.

24. The blank of claim 17, wherein the at least one central panel is a front central panel, the plurality of panels further comprises a back central panel for being positioned in at least partial face-to-face contact with the front central panel when the carrier is formed from the blank, and at least one of the front central panel and the back central panel comprises a respective at least one opening for being positioned in communication with the respective other of the front central panel and the back central panel.

25. The blank of claim 24, wherein each of the front central panel and the back central panel comprises a respective at least one opening for being positioned in communication with the respective other of the front central panel and the back central panel when the carrier is formed from the blank.

26. The blank of claim 25, wherein the front central panel is foldably connected to the back central panel at a lateral fold line, the at least one opening in the front central panel is spaced a first longitudinal distance from the fold line, the at least one opening in the back central panel is spaced a second longitudinal distance from the fold line, the first longitudinal distance is greater than the second longitudinal distance.

27. The blank of claim 25, wherein the at least one attachment panel is a front attachment panel, the at least one side panel is a front side panel, the at least one top panel is a front top panel, and the plurality of panels further comprises a back attachment panel, a back side panel, and a back top panel, the back attachment panel configured receive a portion of one or more containers of the plurality of containers when the carrier is formed from the blank.

28. The blank of claim 17, wherein the at least one top panel comprises at least one handle feature and the at least one central panel comprises at least a portion of at least one handle opening, the at least one handle feature of the top panel is for being aligned with the at least a portion of the at least one handle opening when the carrier is formed from the blank.

29. A method of forming a carrier for holding a plurality of containers, the method comprising:

obtaining a blank comprising a plurality of panels comprising at least one central panel, at least one attachment panel, at least one side panel, and at least one top panel, the blank further comprising at

least one reinforcement panel positioned between the at least one attachment panel and the at least one top panel;

folding the plurality of panels to form the carrier such that the at least one attachment panel receives a portion of one or more containers of the plurality of containers;

positioning the at least one central panel between adjacent containers of the plurality of containers; and

attaching the at least one central panel to adjacent containers of the plurality of containers.

30. The method of claim 29, wherein the at least one reinforcement panel is generally upright relative to the at least one central panel.

31. The method of claim 30, wherein the at least one reinforcement panel is formed by a line of weakening.

32. The method of claim 31, wherein the at least one reinforcement panel is at least partially formed in the at least one side panel.

33. The method of claim 32, wherein the line of weakening includes at least one curved segment intersecting a pair of oblique segments.

34. The method of claim 33, wherein the at least one side panel is foldably connected to the at least one attachment panel at a first fold line, and the at least one top panel is foldably connected to the at least one side panel at a second fold line, the at least one reinforcement panel interrupts at least one of the first fold line and the second fold line.

35. The method of claim 31, wherein the at least one central panel is a front central panel, the at least one attachment panel is a front attachment panel, the at least one side panel is a front side panel, the at least one top panel is a front top panel, and the plurality of panels further comprises a back central panel, a back attachment panel, a back side panel, and a back top panel, and the folding the plurality of panels further comprises positioning the back central panel in at least partial face-to-face contact with the front central panel, and positioning the back attachment panel to receive a portion of one or more containers of the plurality of containers.

36. The method of claim 35, wherein the at least one reinforcement panel is an at least one front reinforcement panel positioned between the front attachment panel and the front top panel, and the carrier further comprises at least one back reinforcement panel positioned between the back attachment panel and the back top panel.

37. The method of claim 30, further comprising adhering the at least one central panel to adjacent containers of the plurality of containers.

38. The method of claim 30, wherein the at least one central panel is a front central panel, the plurality of panels further comprises a back central panel, at least one of the front central panel and the back central panel comprises a respective at least one opening, and the folding the plurality of panels further comprises positioning the back central panel in at least partial face-to-face contact with the front central panel such that the respective at least one opening of the at least one of the front central panel and the back central panel is in communication with the respective other of the front central panel and the back central panel.

39. The method of claim 38, wherein each of the front central panel and the back central panel comprises a respective at least one opening, and the folding the plurality of panels further comprises positioning the respective at least one opening of the at least one of the front central panel and the back central panel in communication with the respective other of the front central panel and the back central panel.

40. The method of claim 38, wherein the at least one opening in the front central panel is offset from the at least one opening in the back central panel.

41. The method of claim 40, wherein a portion of the back central panel is exposed through the at least one opening in the front central panel and a portion of the front central panel is exposed through the at least one opening in the back central panel.

42. The method of claim 40, wherein the front central panel is foldably connected to the back central panel at a lateral fold line, the at least one opening in the front central panel is spaced a first longitudinal distance from the fold line, the at least one opening in the back central panel is spaced a second longitudinal distance from the fold line, the first longitudinal distance is greater than the second longitudinal distance.

43. The method of claim 40, wherein the at least one attachment panel is a front attachment panel, the at least one side panel is a front side panel, the at least one top panel is a front top panel, and the plurality of panels further comprises a back attachment panel, a back side panel, and a back top

panel, and the method further comprises positioning the back attachment panel to receive a portion of one or more containers of the plurality of containers.

44. The method of claim 30, wherein the at least one top panel comprises at least one handle feature and the at least one central panel comprises at least a portion of at least one handle opening, wherein the folding the plurality of panels comprises aligning the at least one handle feature of the top panel with the at least a portion of the at least one handle opening.

45. A package, the package comprising:

a plurality of containers; and

a carrier holding the plurality of containers, the carrier comprising:

a plurality of panels comprising at least one central panel, at least one attachment panel, at least one side panel, and at least one top panel, the at least one attachment panel receiving a portion of one or more containers of the plurality of containers; and

at least one reinforcement panel positioned between the at least one attachment panel and the at least one top panel,

the at least one central panel is positioned between and attached to adjacent containers of the plurality of containers.

46. The package of claim 45, wherein the at least one reinforcement panel is generally upright relative to the at least one central panel.

47. The package of claim 46, wherein the at least one reinforcement panel is formed by a line of weakening.

48. The package of claim 47, wherein the at least one reinforcement panel is at least partially formed in the at least one side panel.

49. The package of claim 48, wherein the line of weakening includes at least one curved segment intersecting a pair of oblique segments.

50. The package of claim 49, wherein the at least one side panel is foldably connected to the at least one attachment panel at a first fold line, and the at least one top panel is foldably connected to the at least one side panel at a second fold line, the at least one reinforcement panel interrupts at least one of the first fold line and the second fold line.

51. The package of claim 47, wherein the at least one central panel is a front central panel, the at least one attachment panel is a front attachment panel, the at least one side panel is a front side panel, the at least one top panel is a front top panel, and the plurality of panels further comprises a back central panel in at least partial face-to-face contact with the front central panel and positioned between and attached to adjacent containers of the plurality of containers, a back attachment panel, a back side panel, and a back top panel, the back attachment panel receiving a portion of one or more containers of the plurality of containers.

52. The package of claim 51, wherein the at least one reinforcement panel is an at least one front reinforcement panel positioned between the front attachment panel and the front top panel, and the carrier further comprises at least one back reinforcement panel positioned between the back attachment panel and the back top panel.

53. The package of claim 46, wherein the at least one central panel is adhered to adjacent containers of the plurality of containers.

54. The package of claim 46, wherein the at least one central panel is a front central panel, the plurality of panels further comprises a back central panel in at least partial face-to-face contact with the front central panel, and at least one of the front central panel and the back central panel comprises a respective at least one opening in communication with the respective other of the front central panel and the back central panel.

55. The package of claim 54, wherein each of the front central panel and the back central panel comprises a respective at least one opening in communication with the respective other of the front central panel and the back central panel.

56. The package of claim 55, wherein the at least one opening in the front central panel is offset from the at least one opening in the back central panel.

57. The package of claim 56, wherein a portion of the back central panel is exposed through the at least one opening in the front central panel and a portion of the front central panel is exposed through the at least one opening in the back central panel.

58. The package of claim 56, wherein the front central panel is foldably connected to the back central panel at a lateral fold line, the at least one opening in the front central panel is spaced a first longitudinal distance from the fold line, the at least one opening in the back central panel is spaced a second longitudinal distance from the fold line, the first longitudinal distance is greater than the second longitudinal distance.

59. The package of claim 56, wherein the at least one attachment panel is a front attachment panel, the at least one side panel is a front side panel, the at least one top panel is a front top panel, and the plurality of panels further comprises a back attachment panel, a back side panel, and a back top panel, the back attachment panel receiving a portion of one or more containers of the plurality of containers.

60. The package of claim 46, wherein the at least one top panel comprises at least one handle feature and the at least one central panel comprises at least a portion of at least one handle opening, the at least one handle feature of the top panel is aligned with the at least a portion of the at least one handle opening.

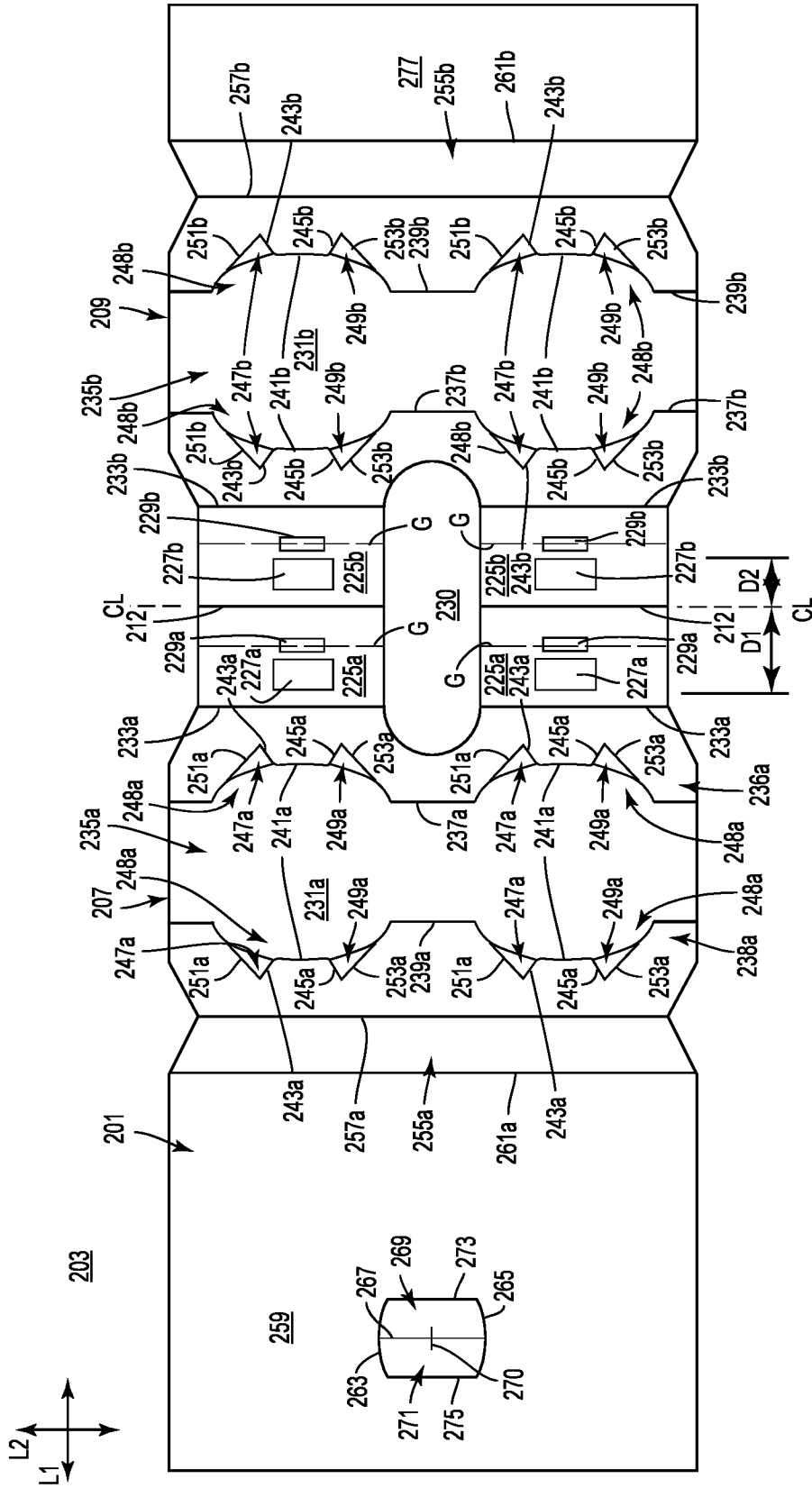

FIG. 1

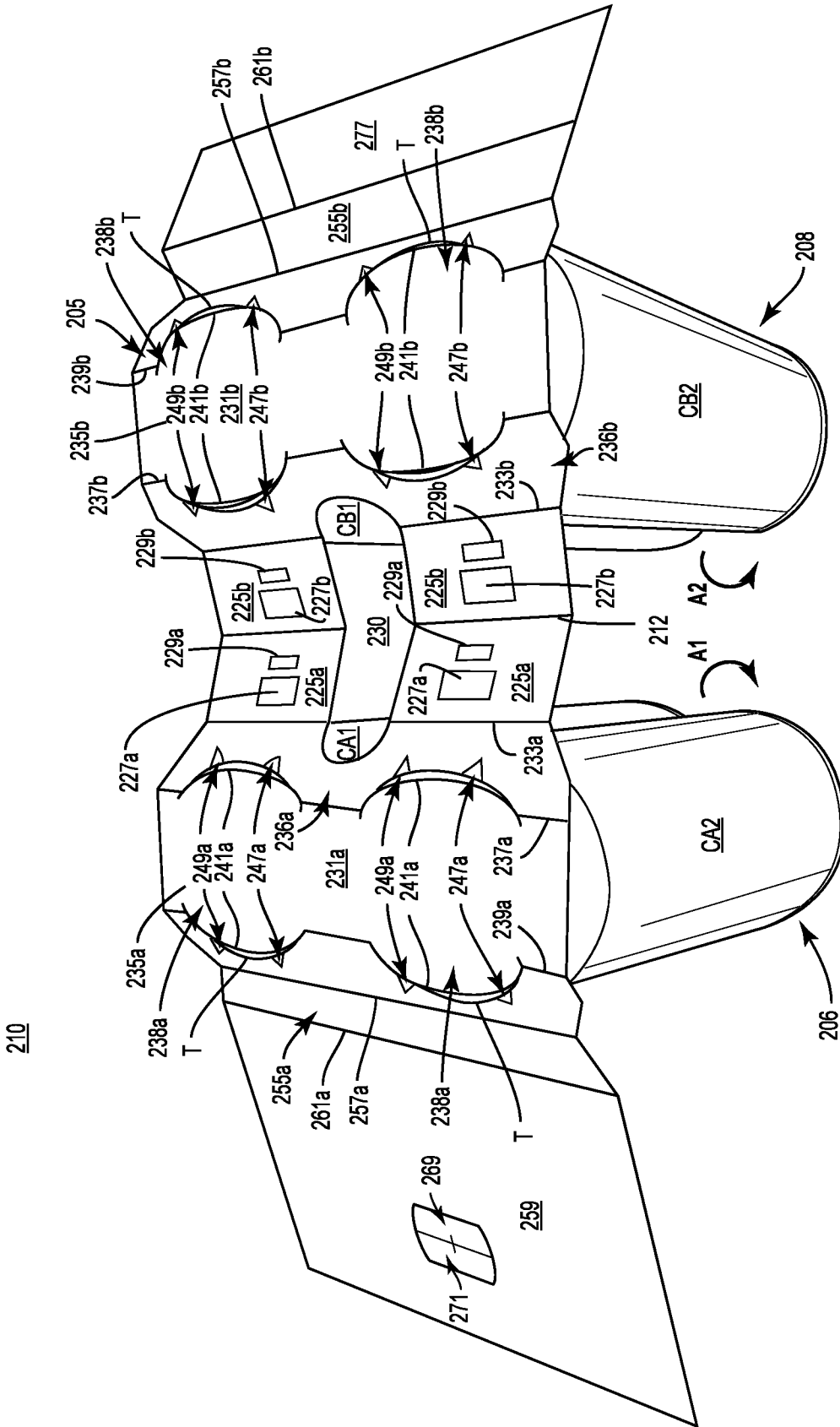
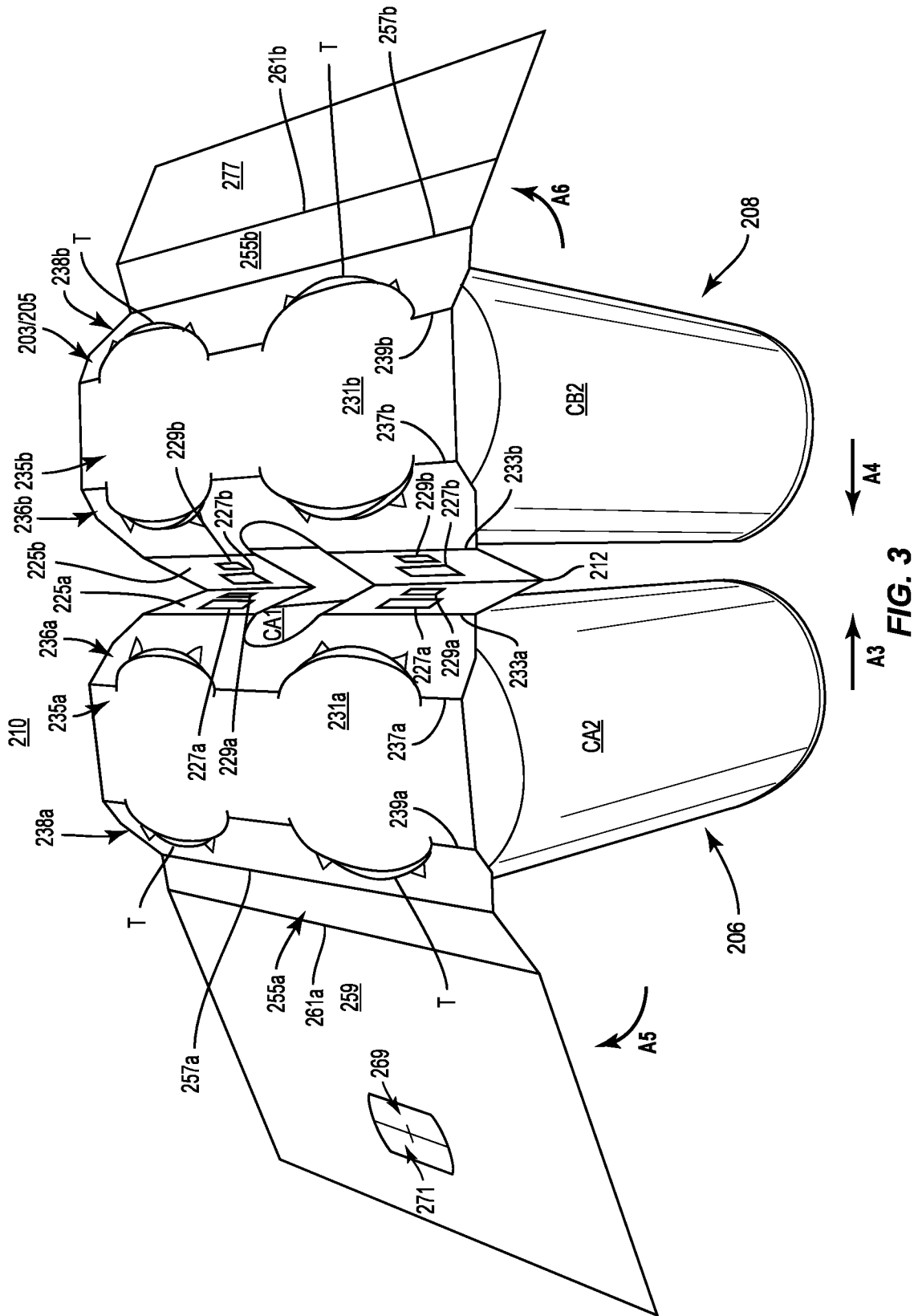

FIG. 2



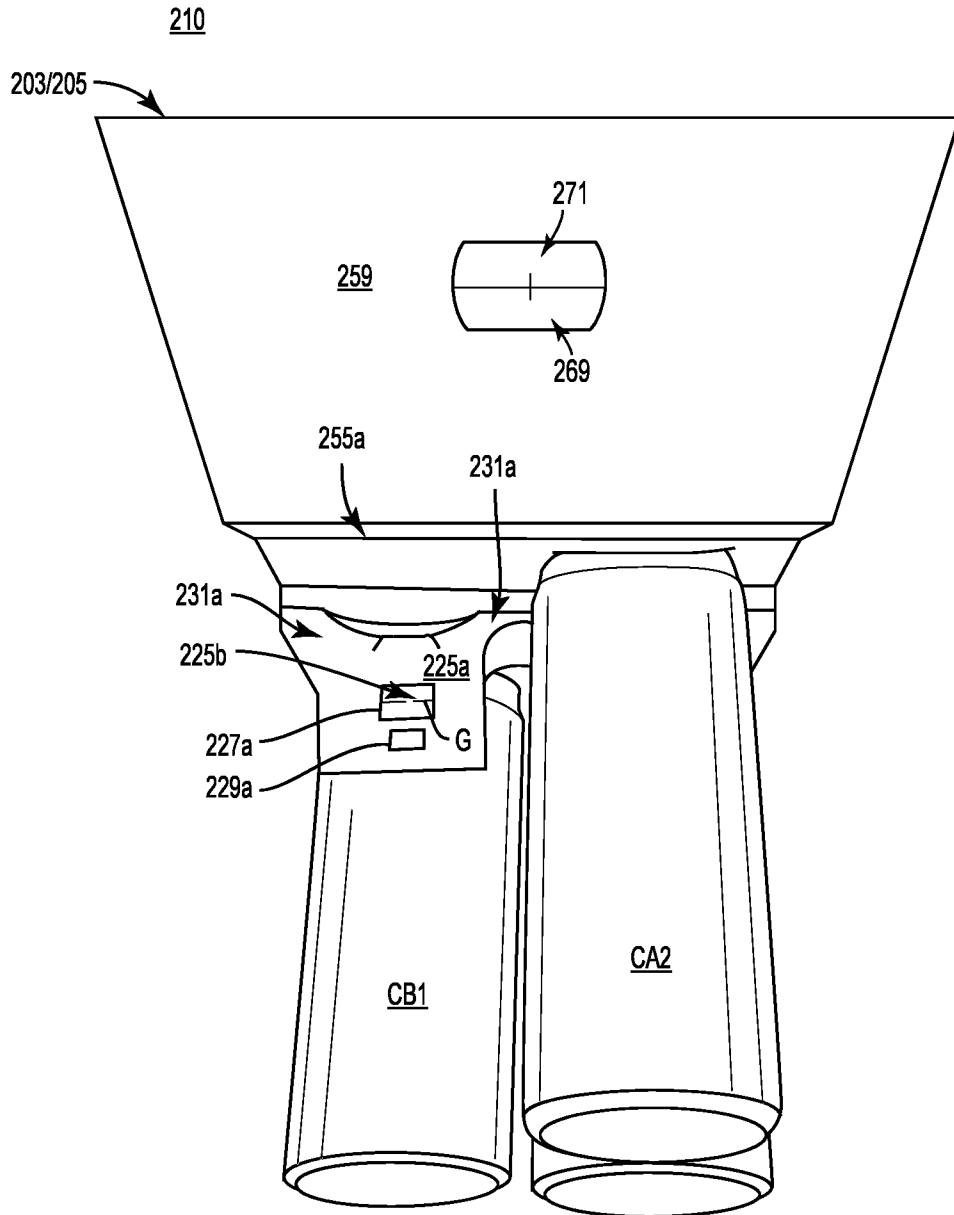

FIG. 4

5/32

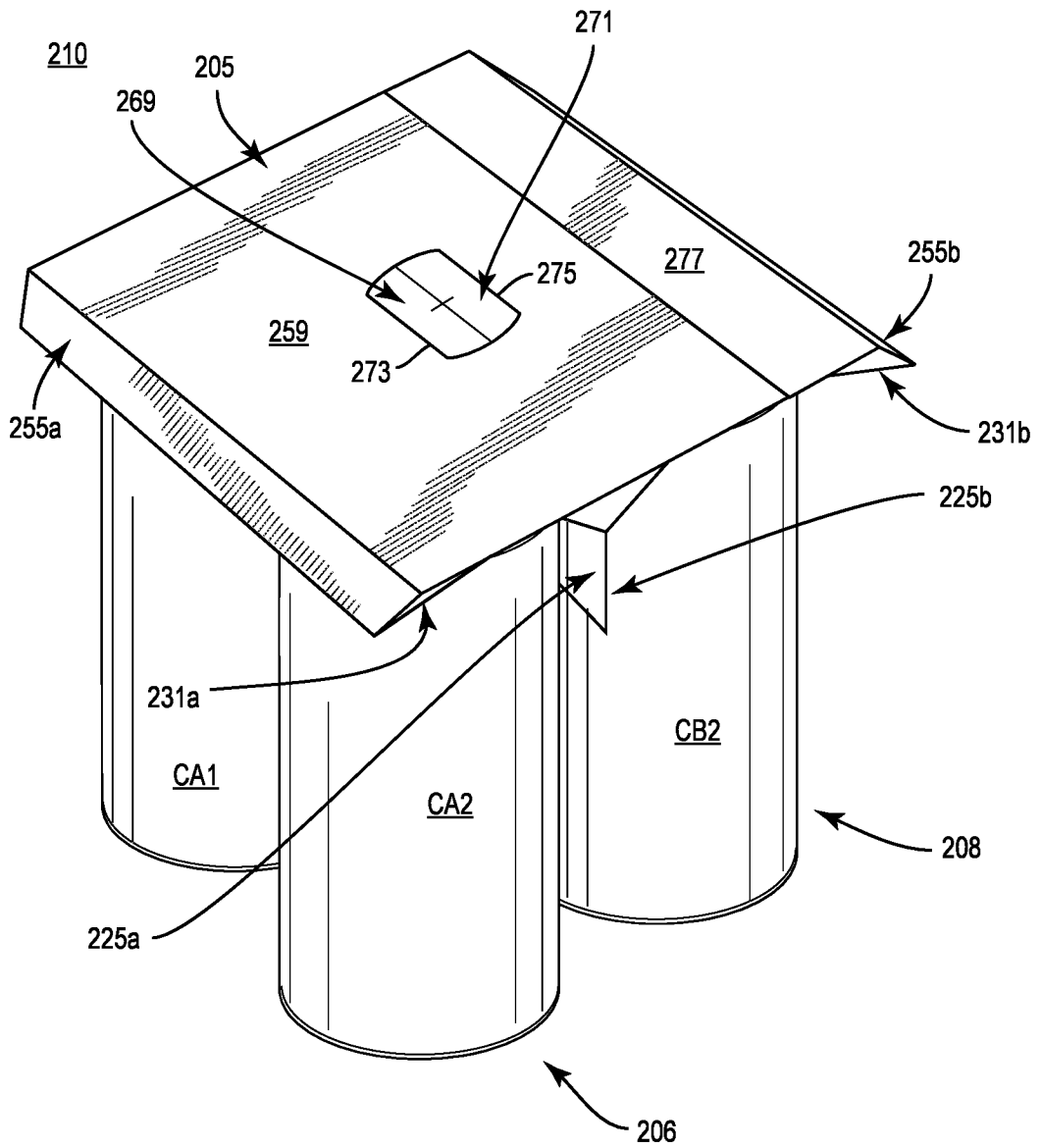

FIG. 5

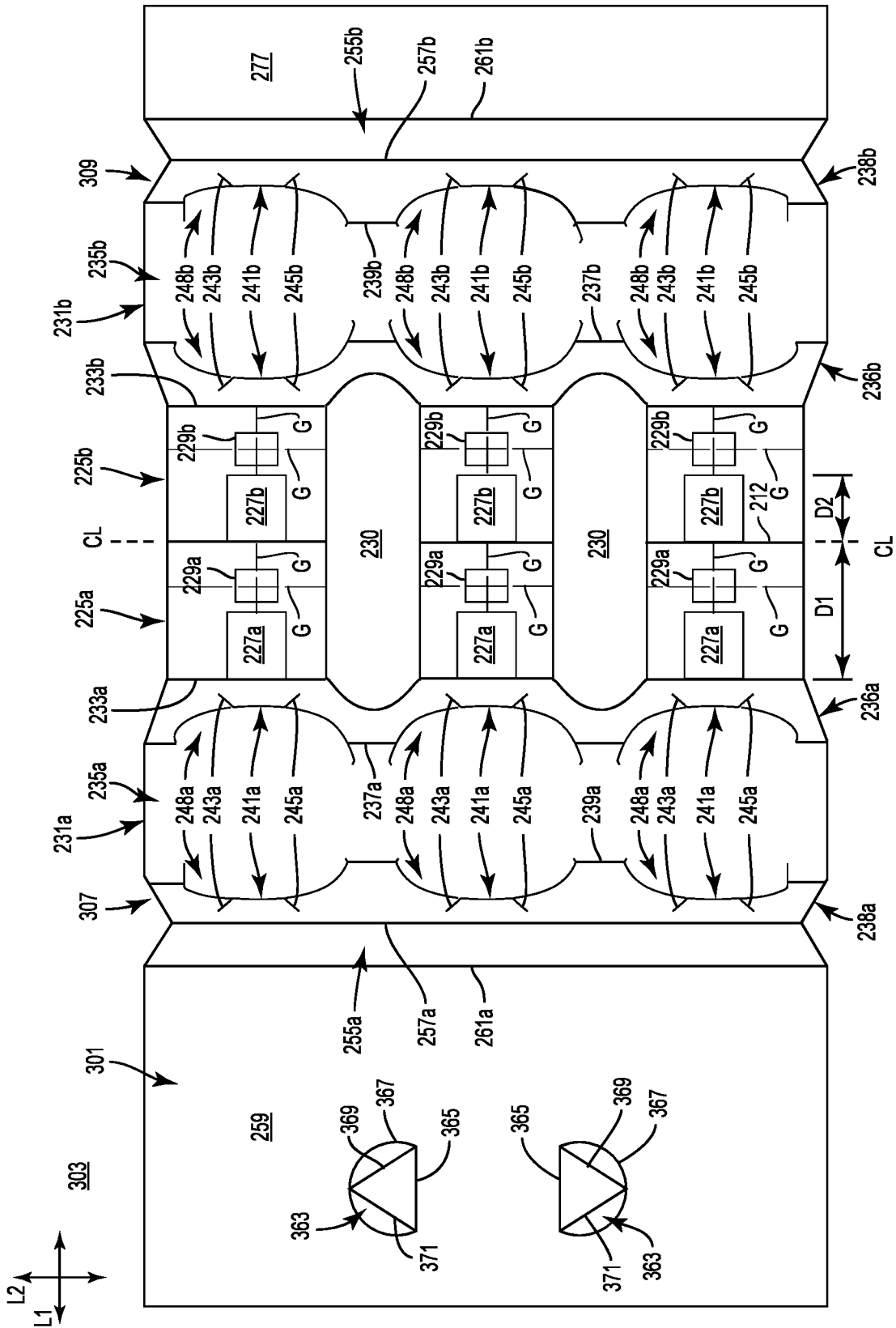

FIG. 6

7/32

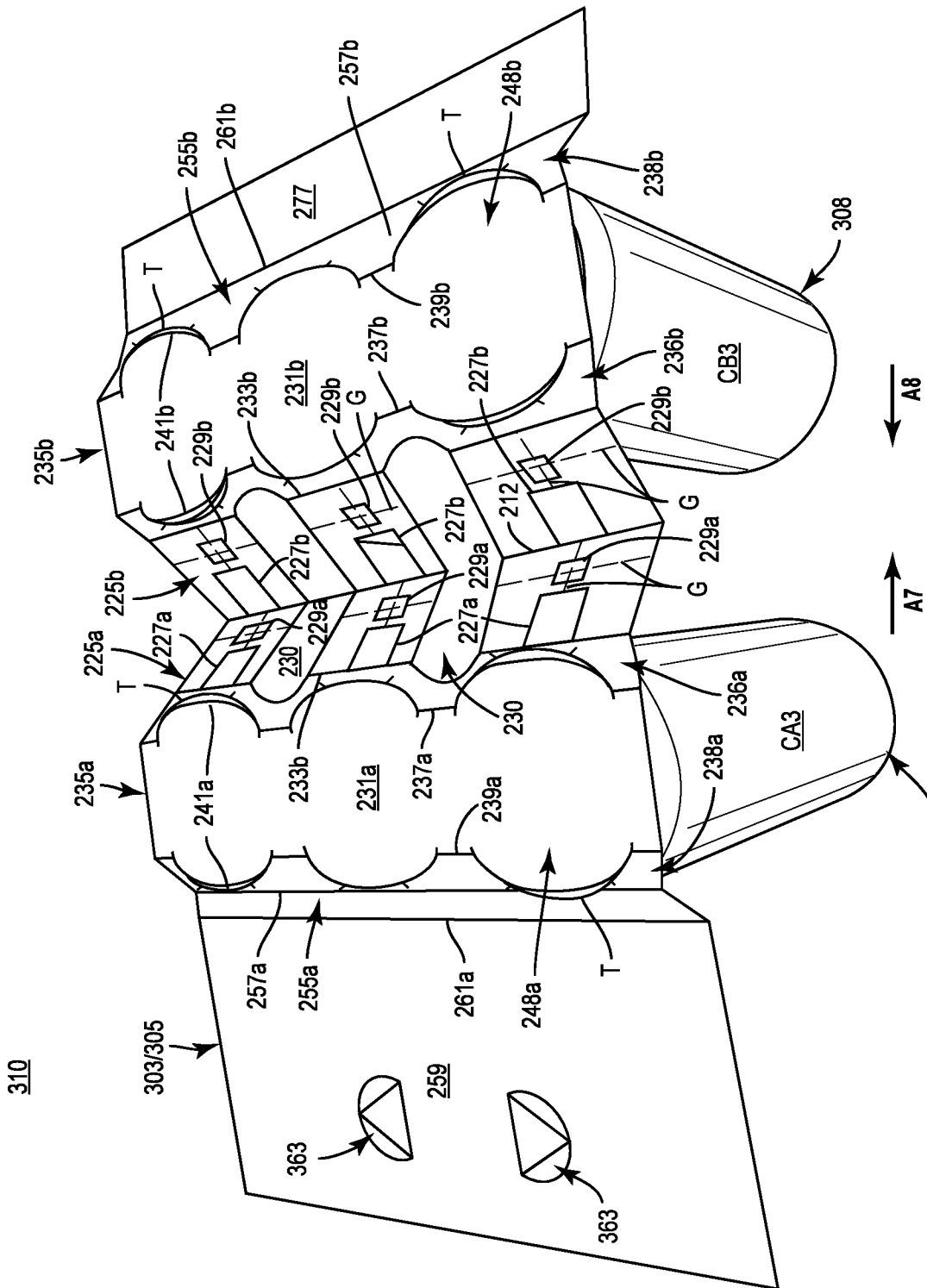

FIG. 7

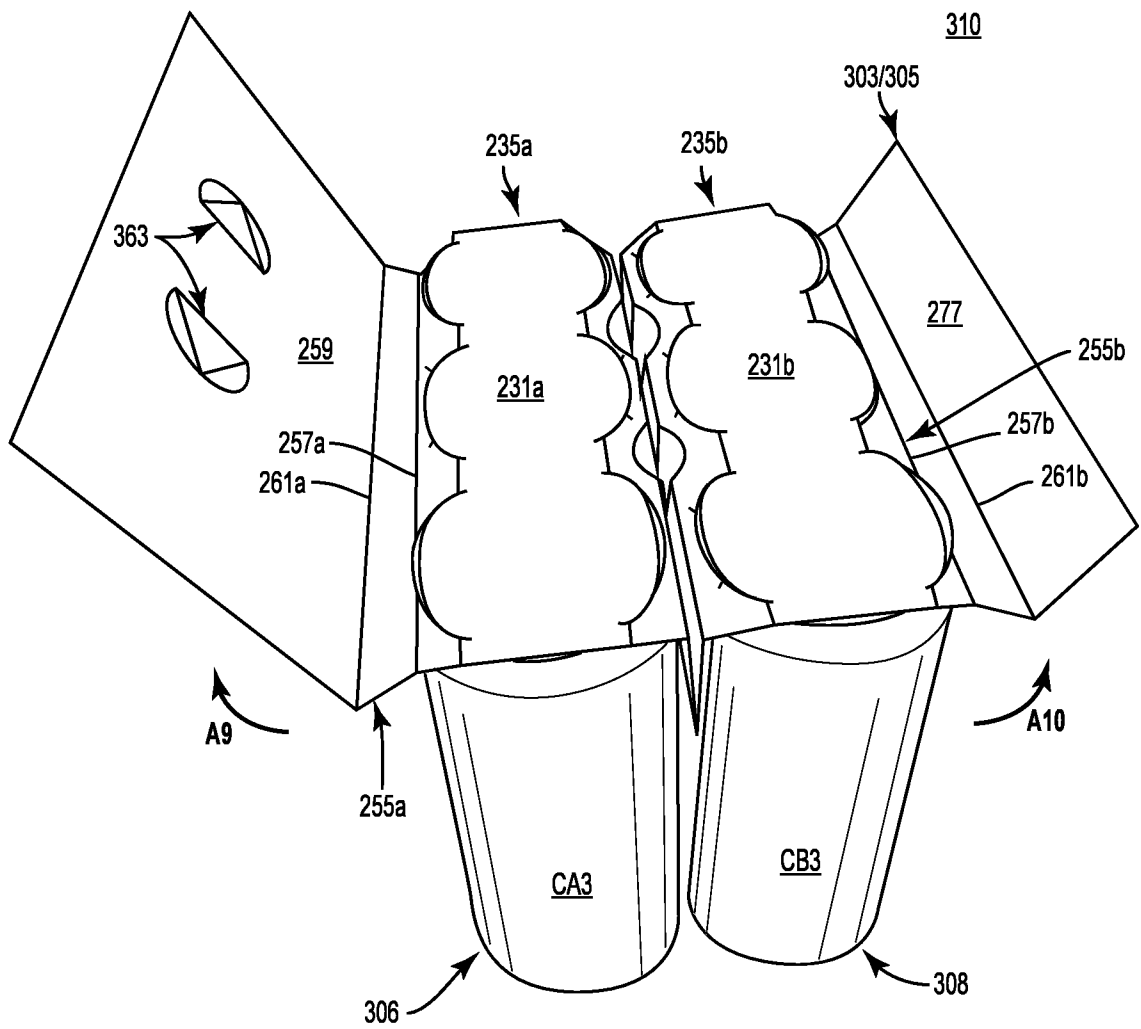

FIG. 8

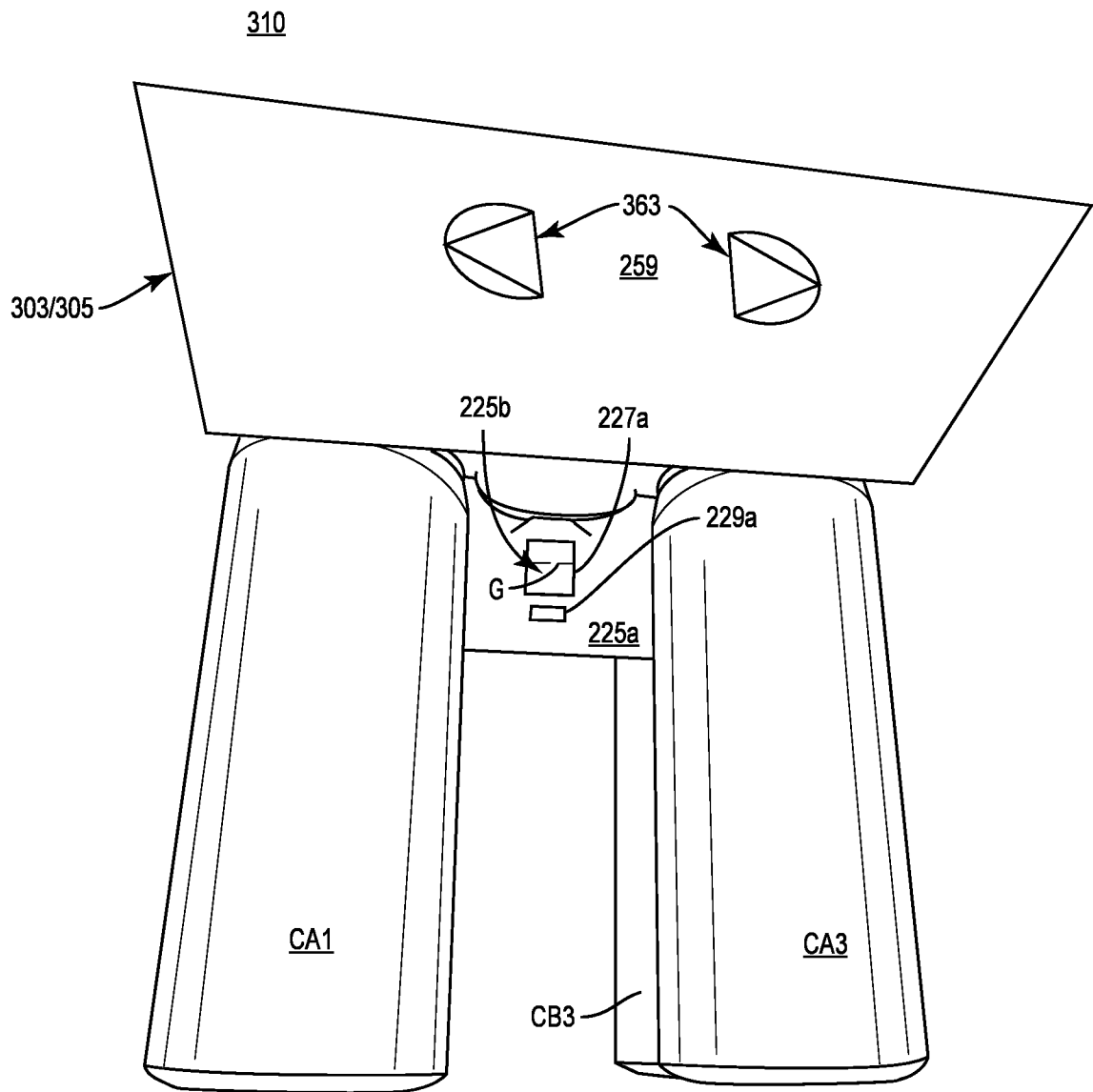

FIG. 9

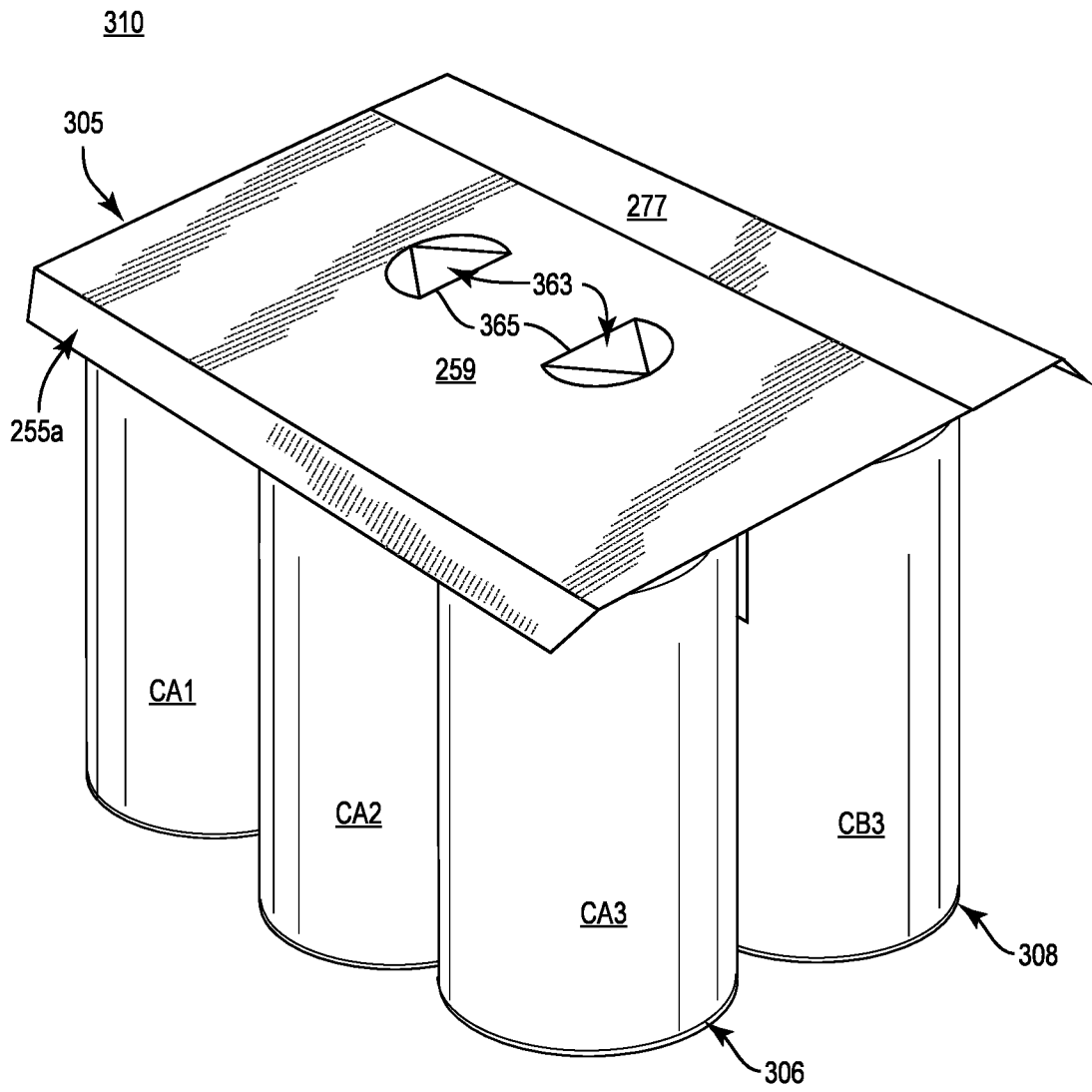

FIG. 10

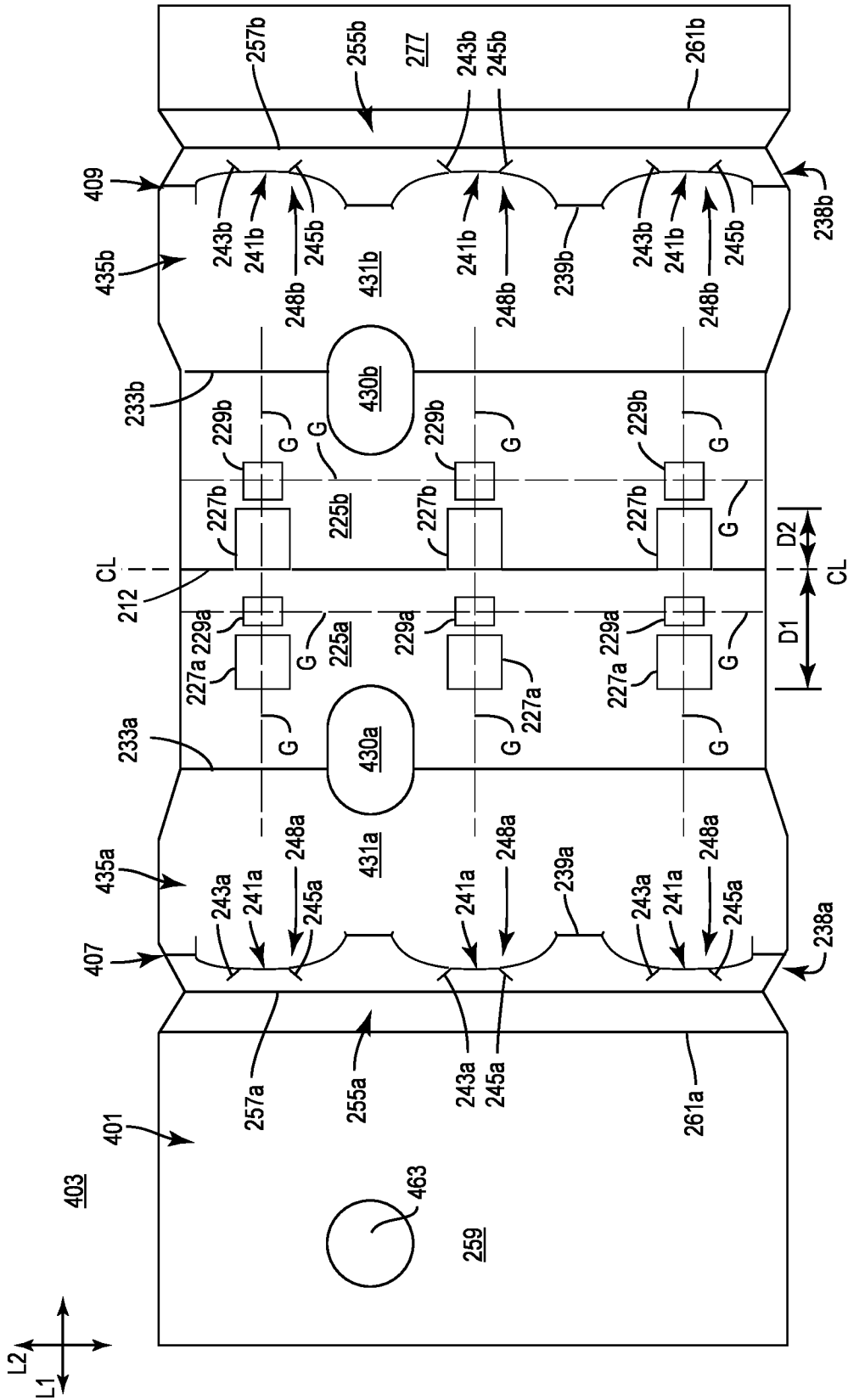

FIG. 11

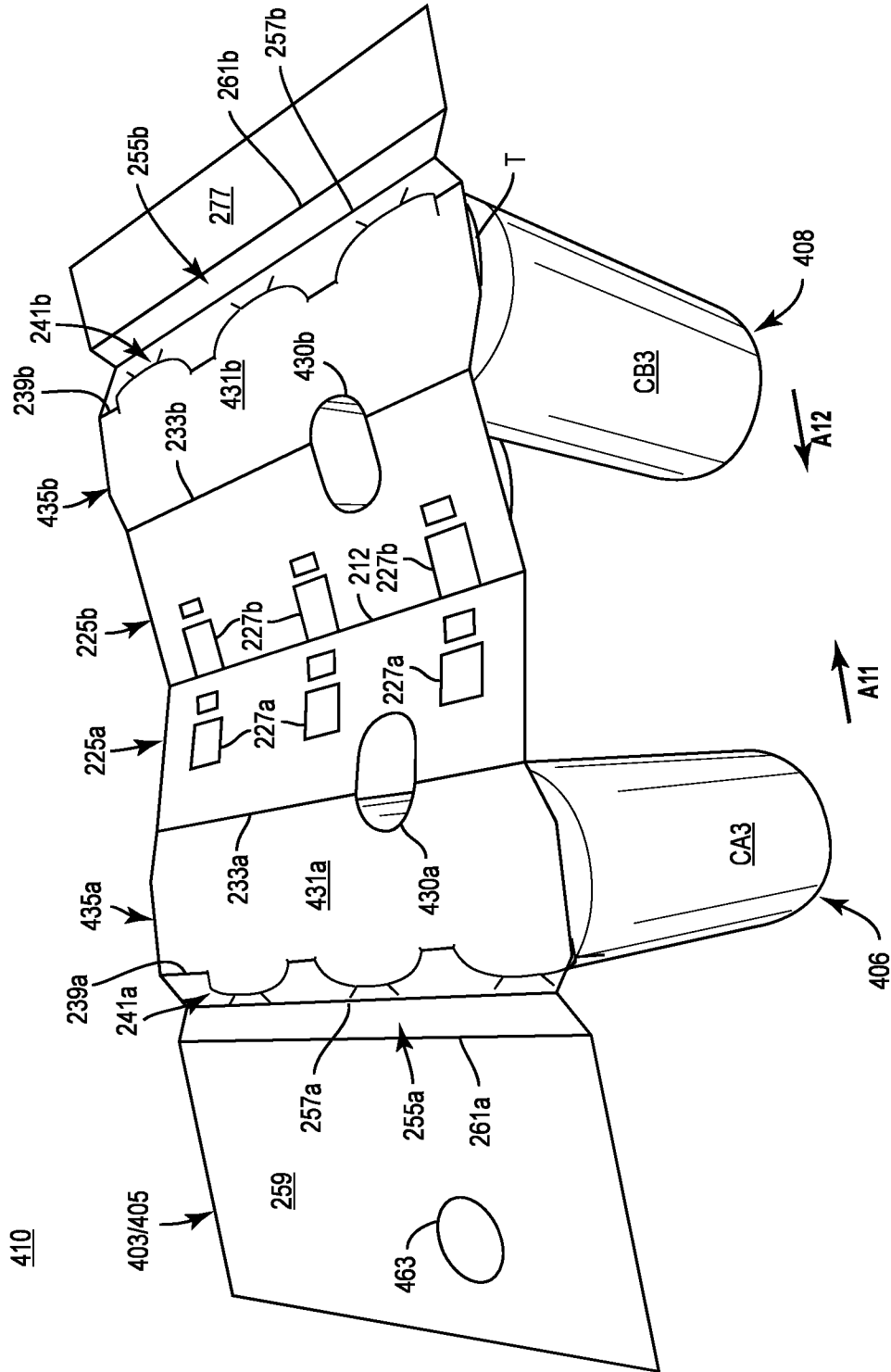

FIG. 12

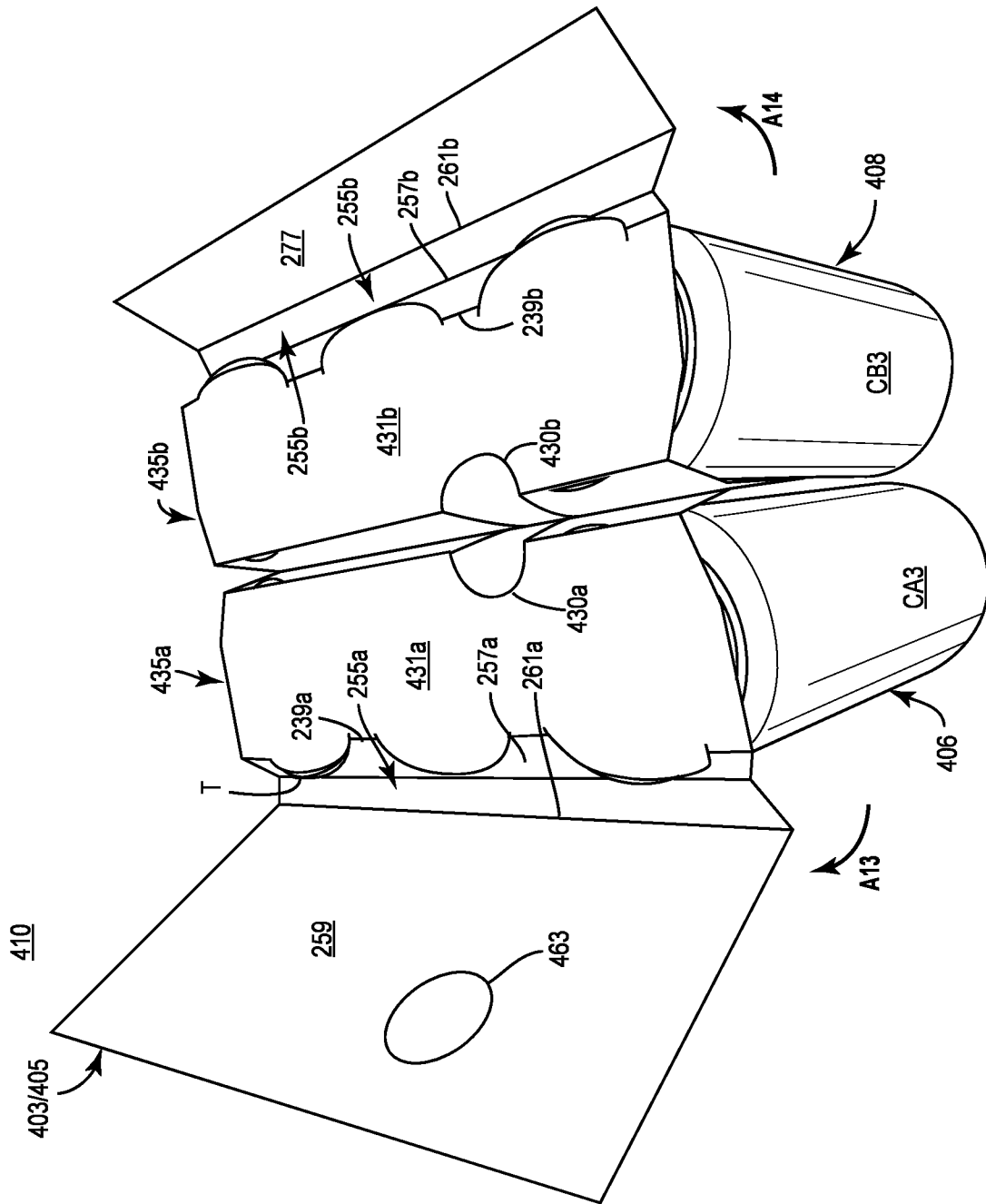

FIG. 13

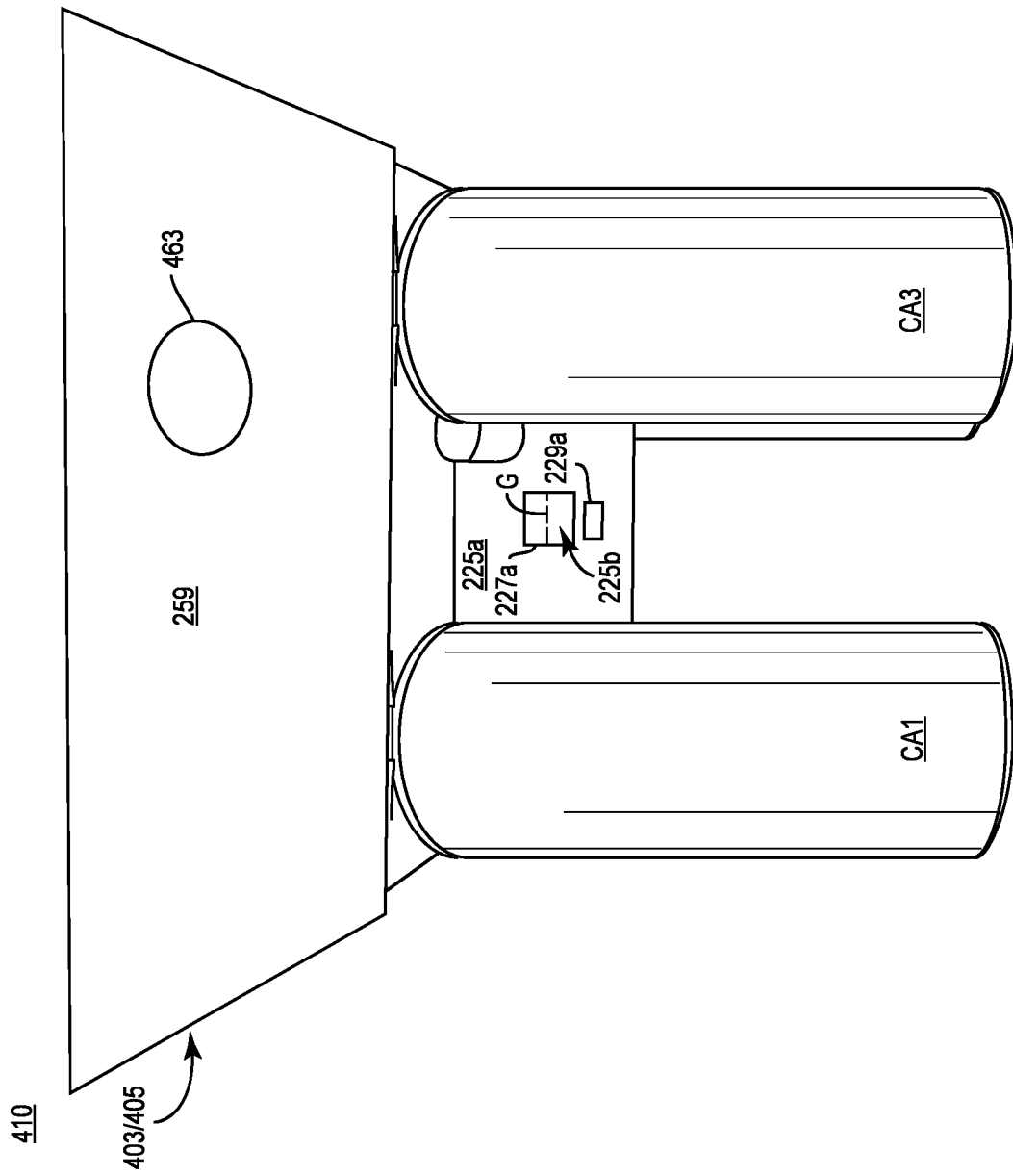

FIG. 14

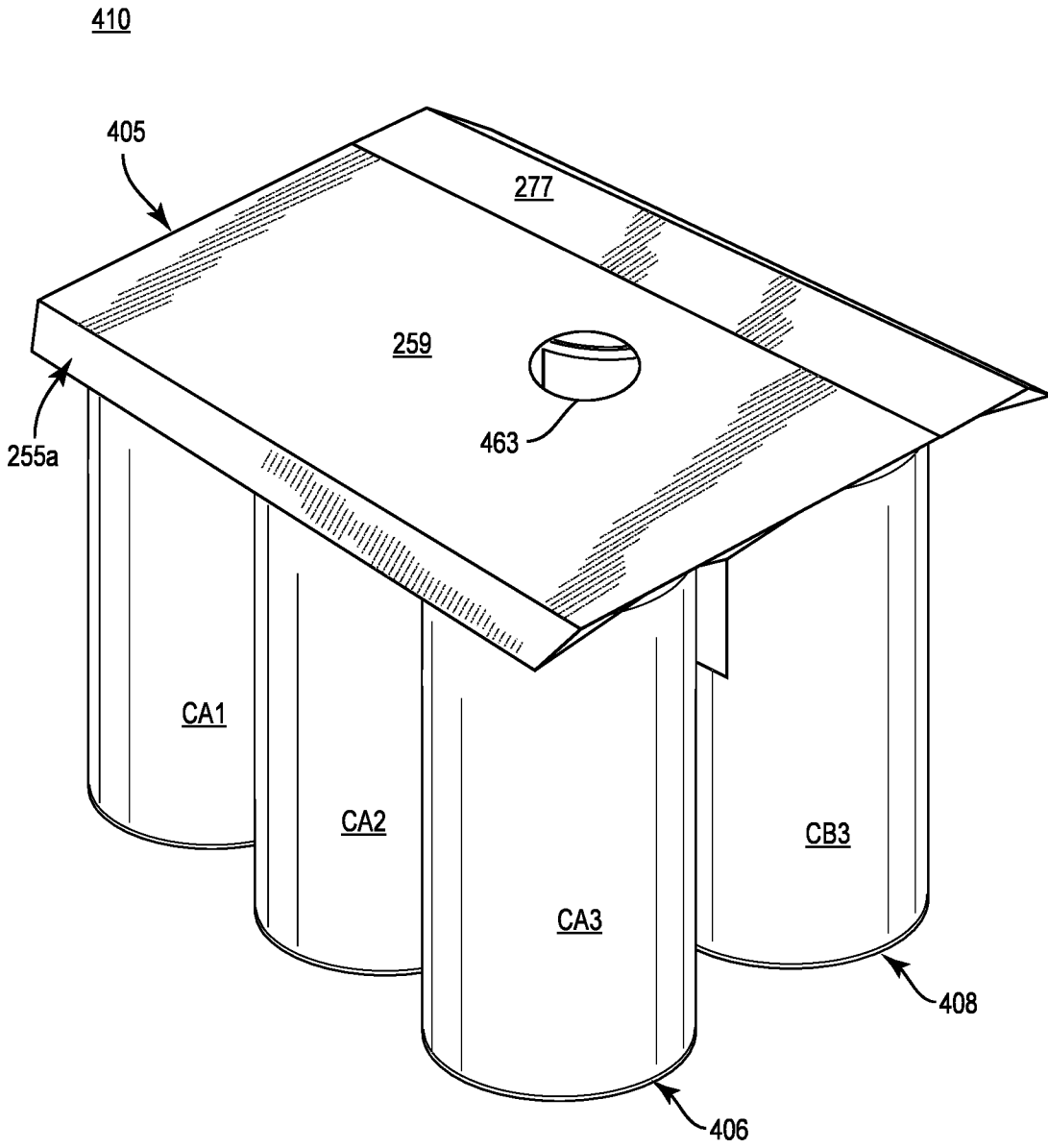

FIG. 15

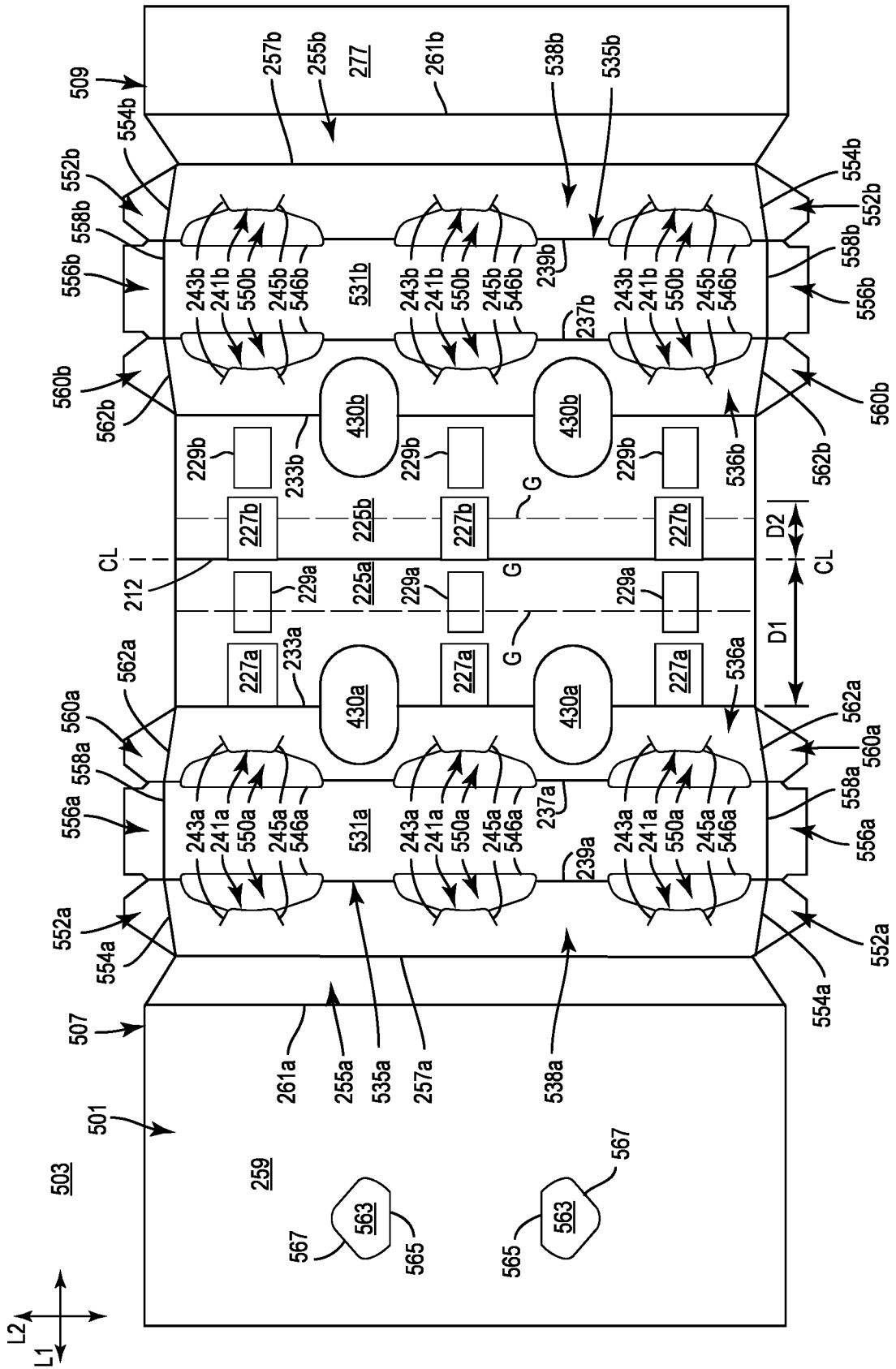

FIG. 16

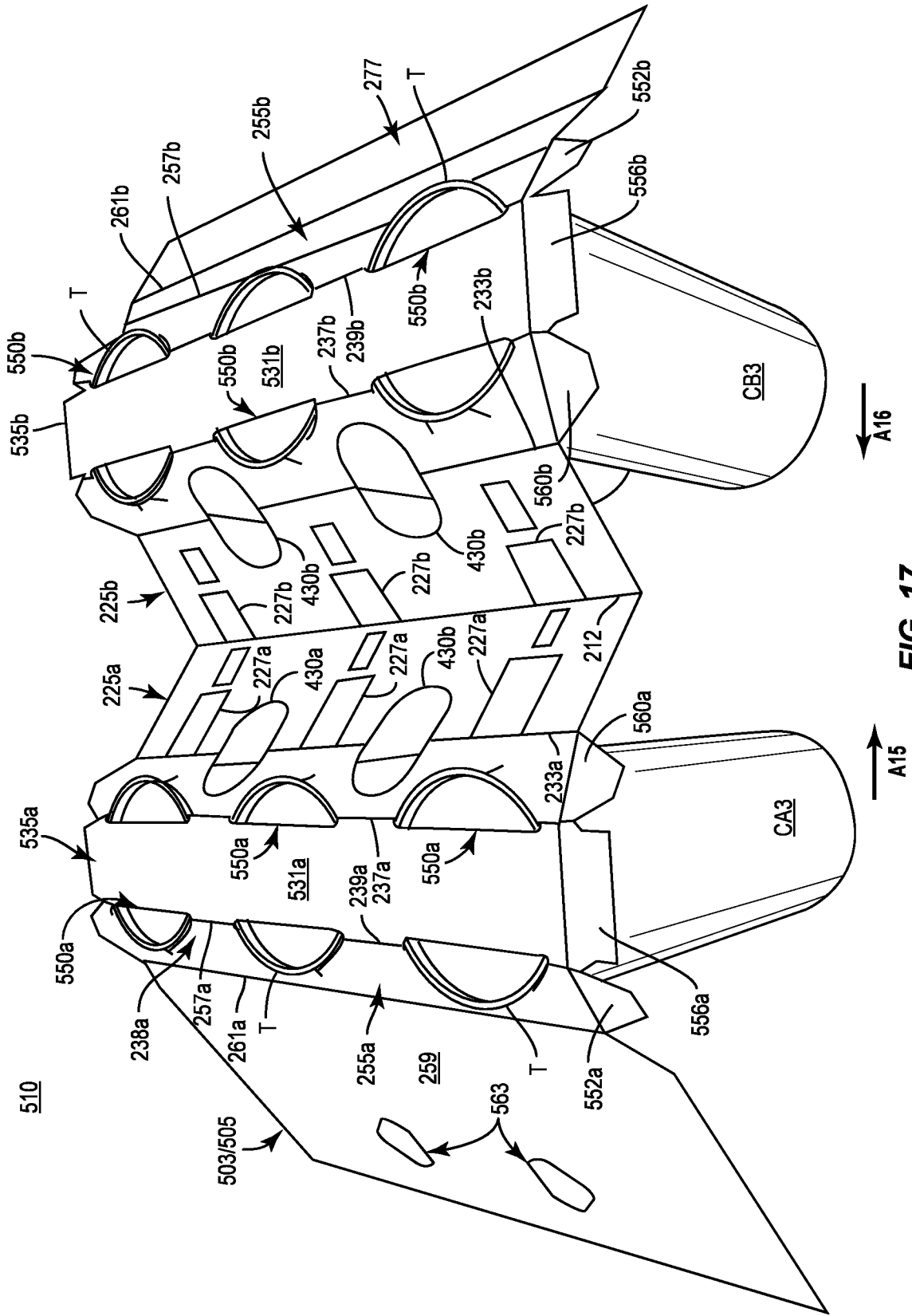

FIG. 17

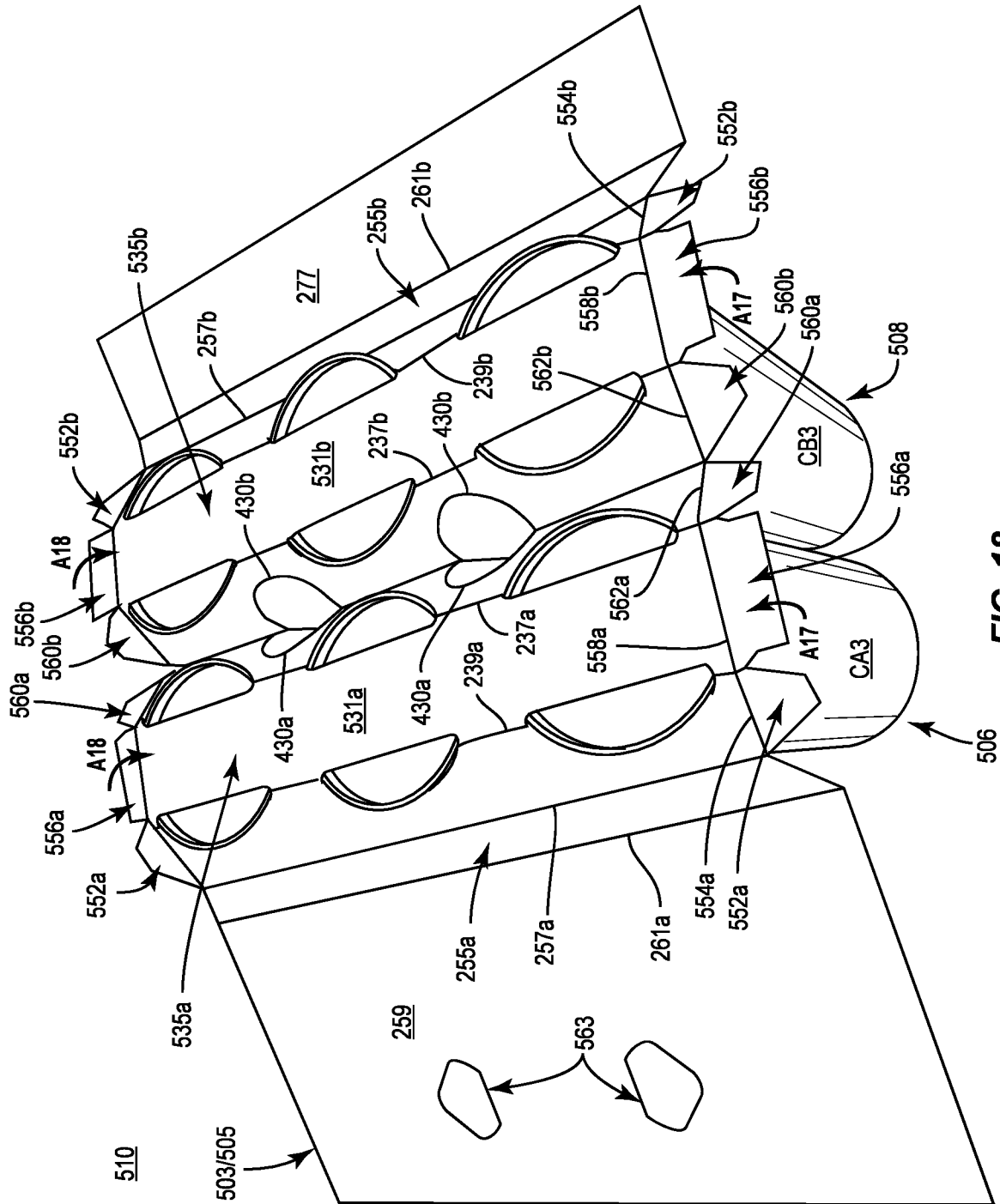

FIG. 18

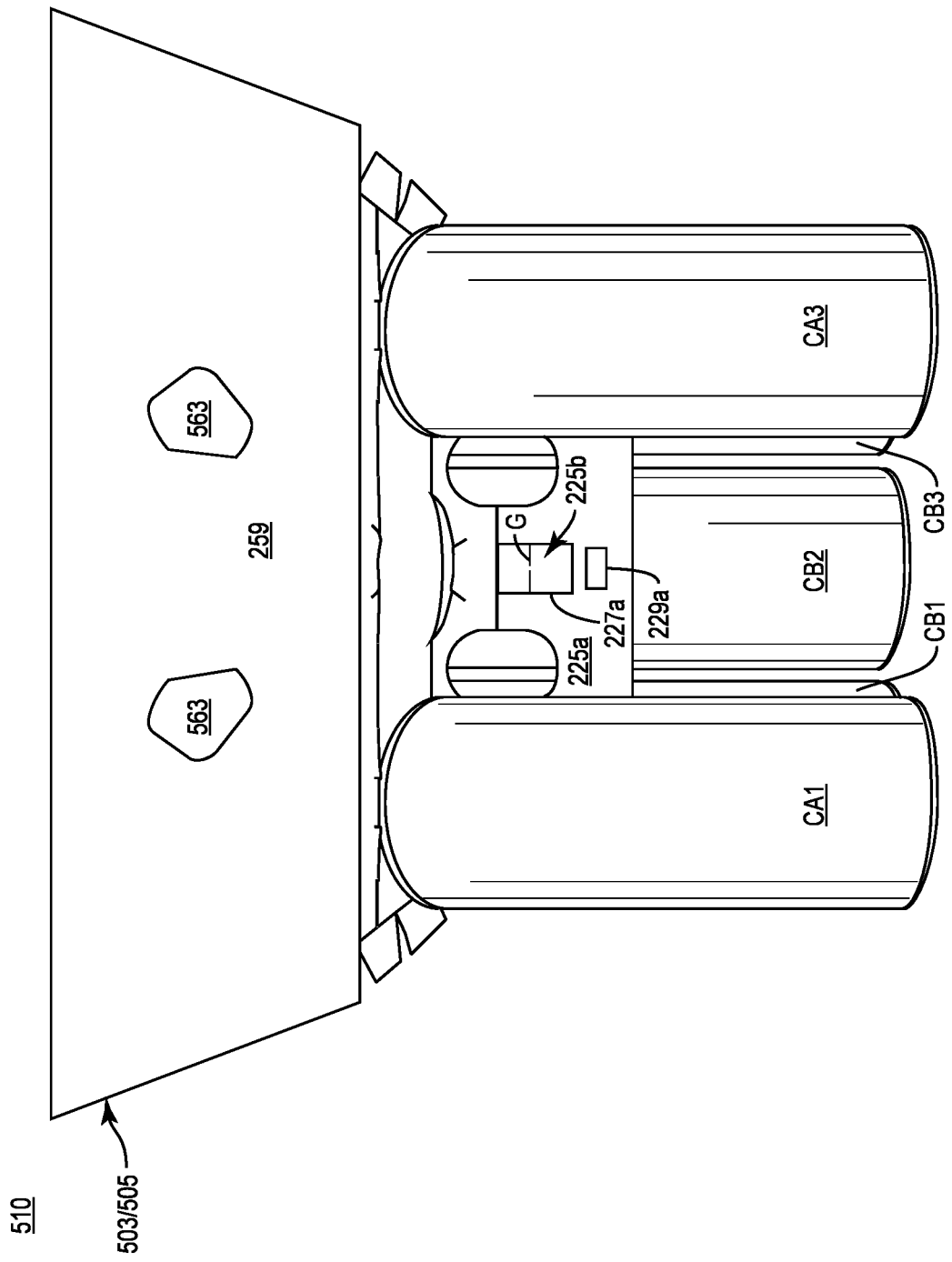

FIG. 19

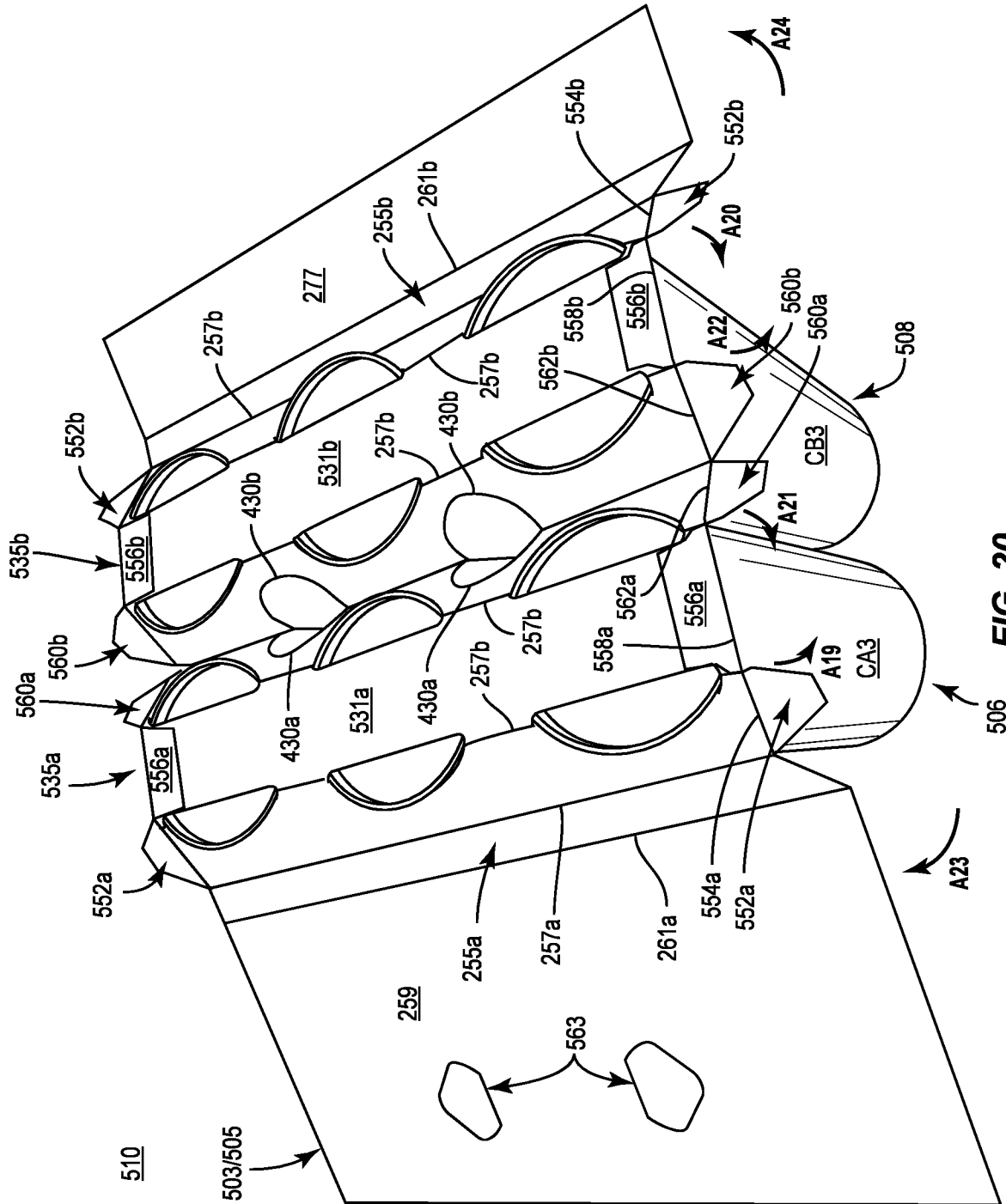

FIG. 20

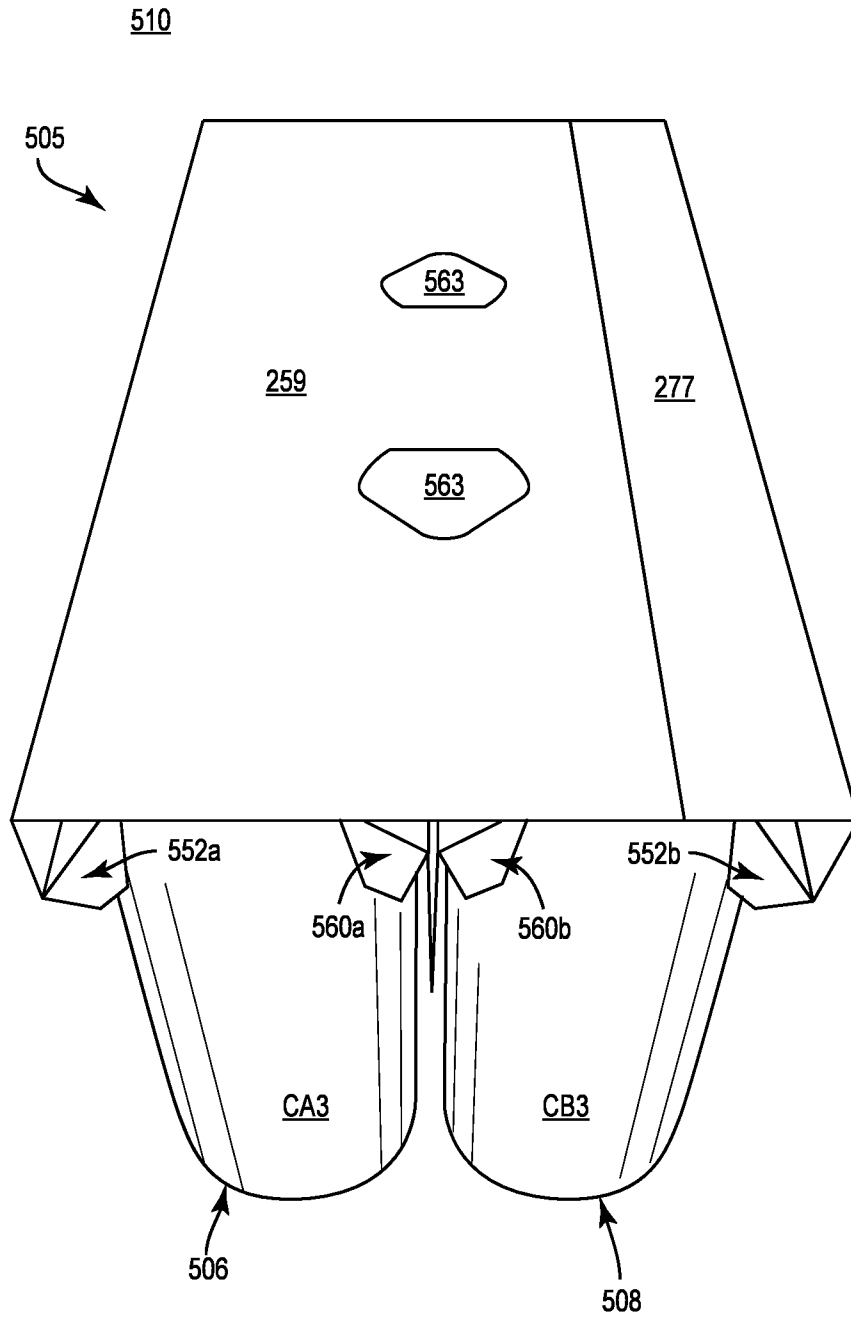

FIG. 21

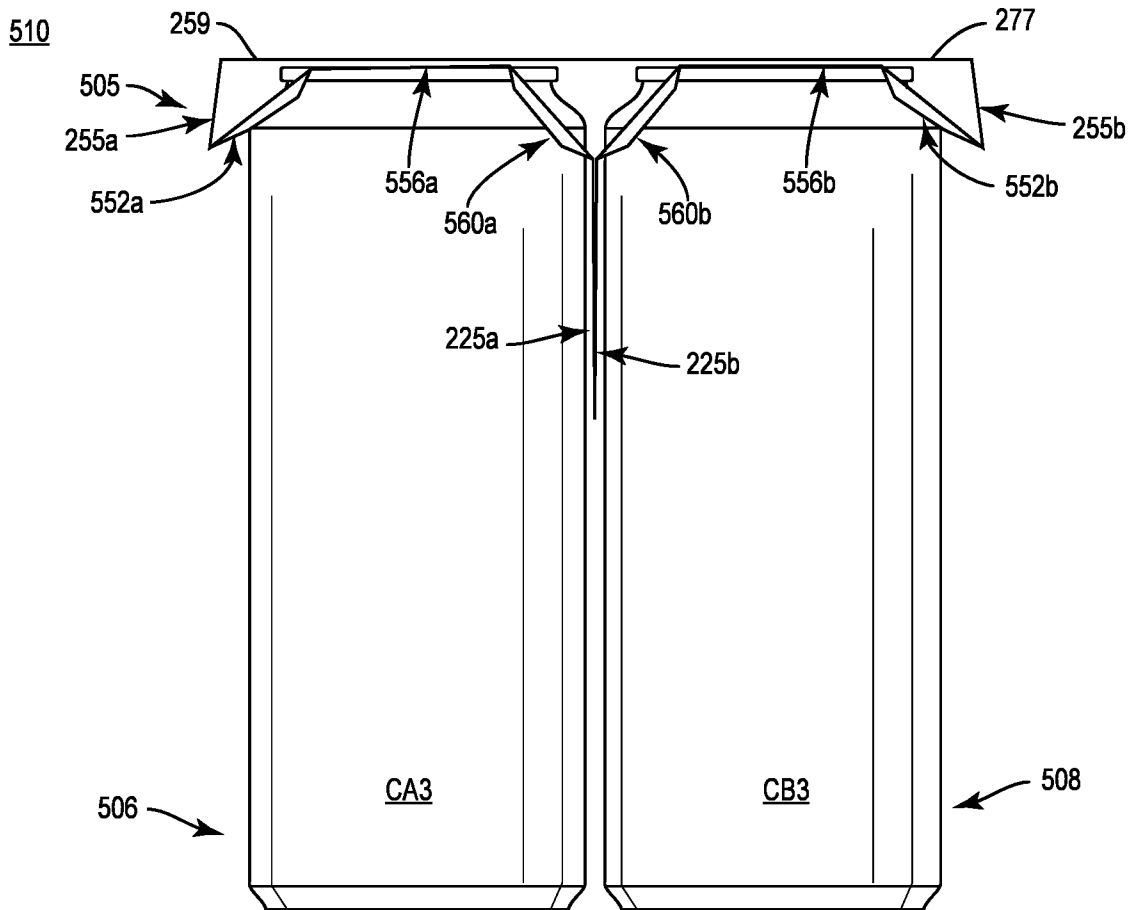

FIG. 22

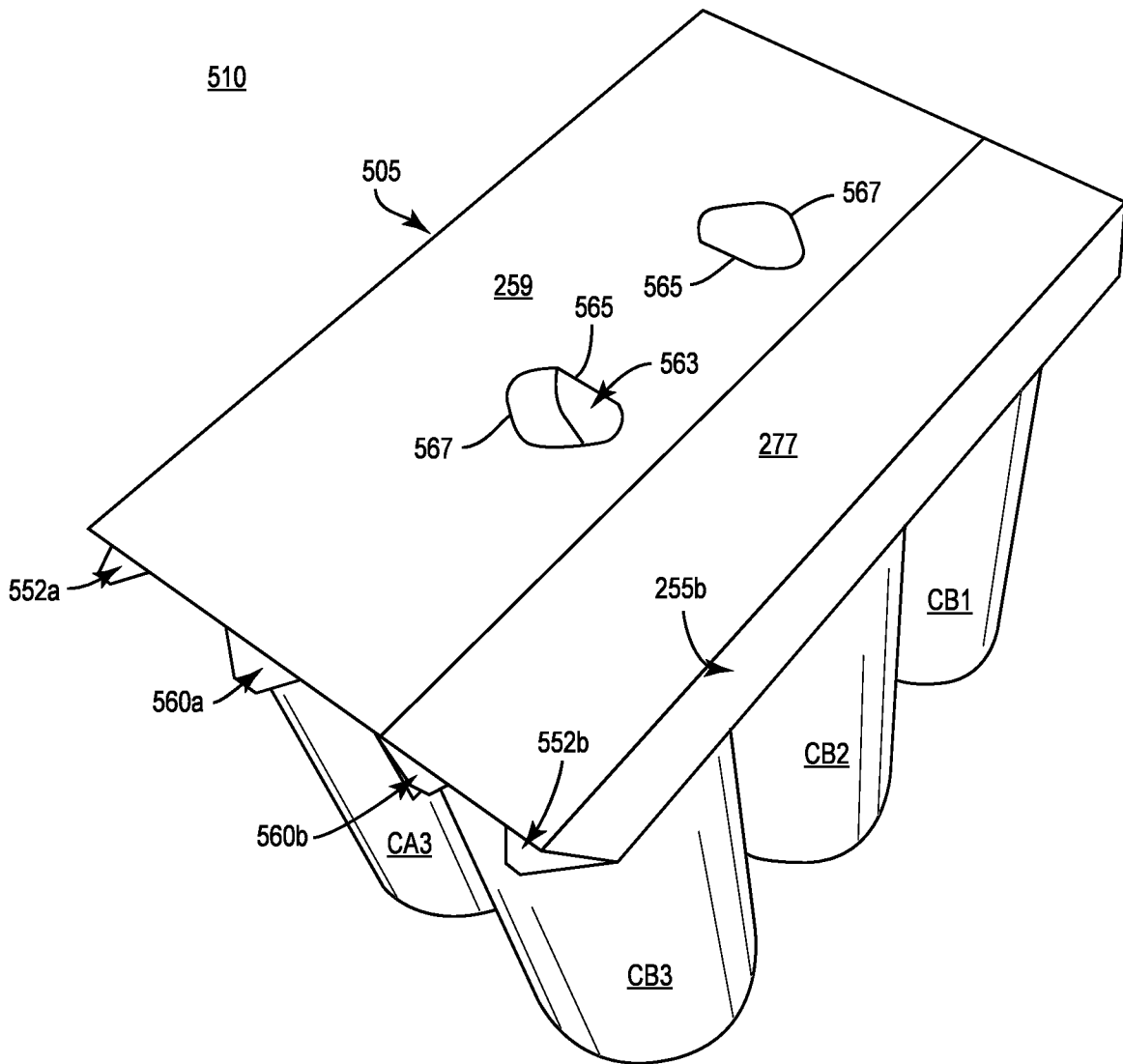

FIG. 23

603

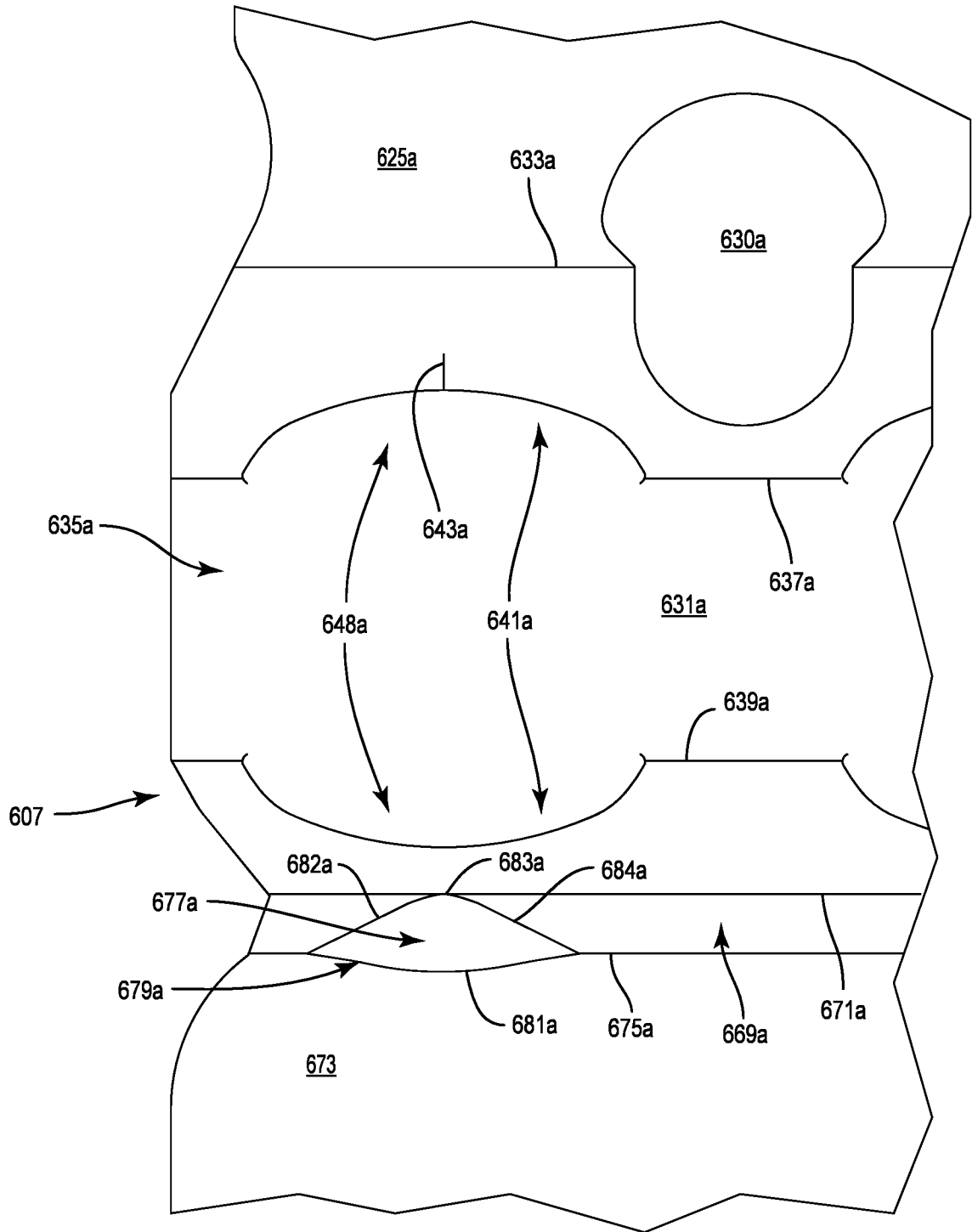

FIG. 24A

603

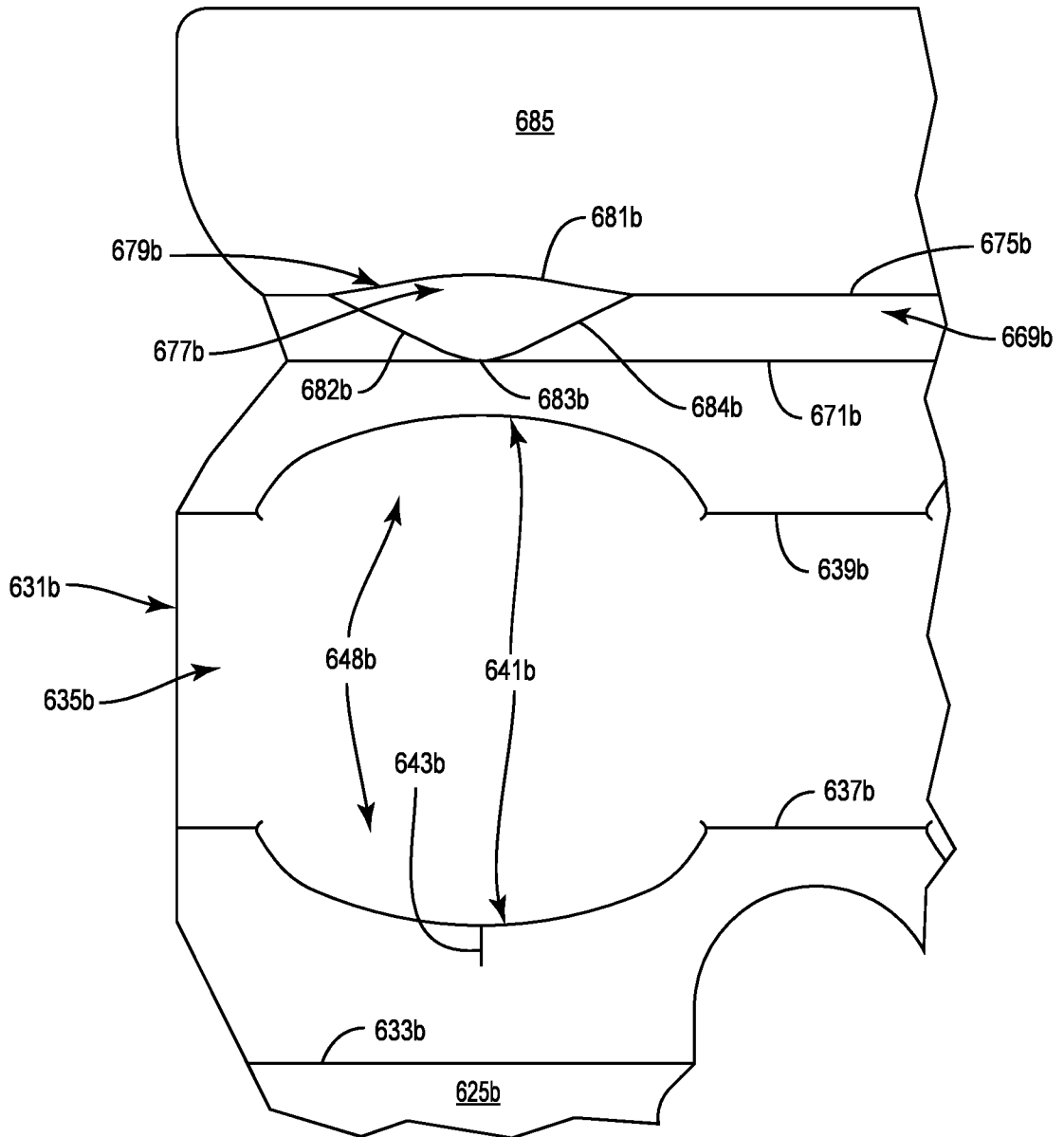

FIG. 24B

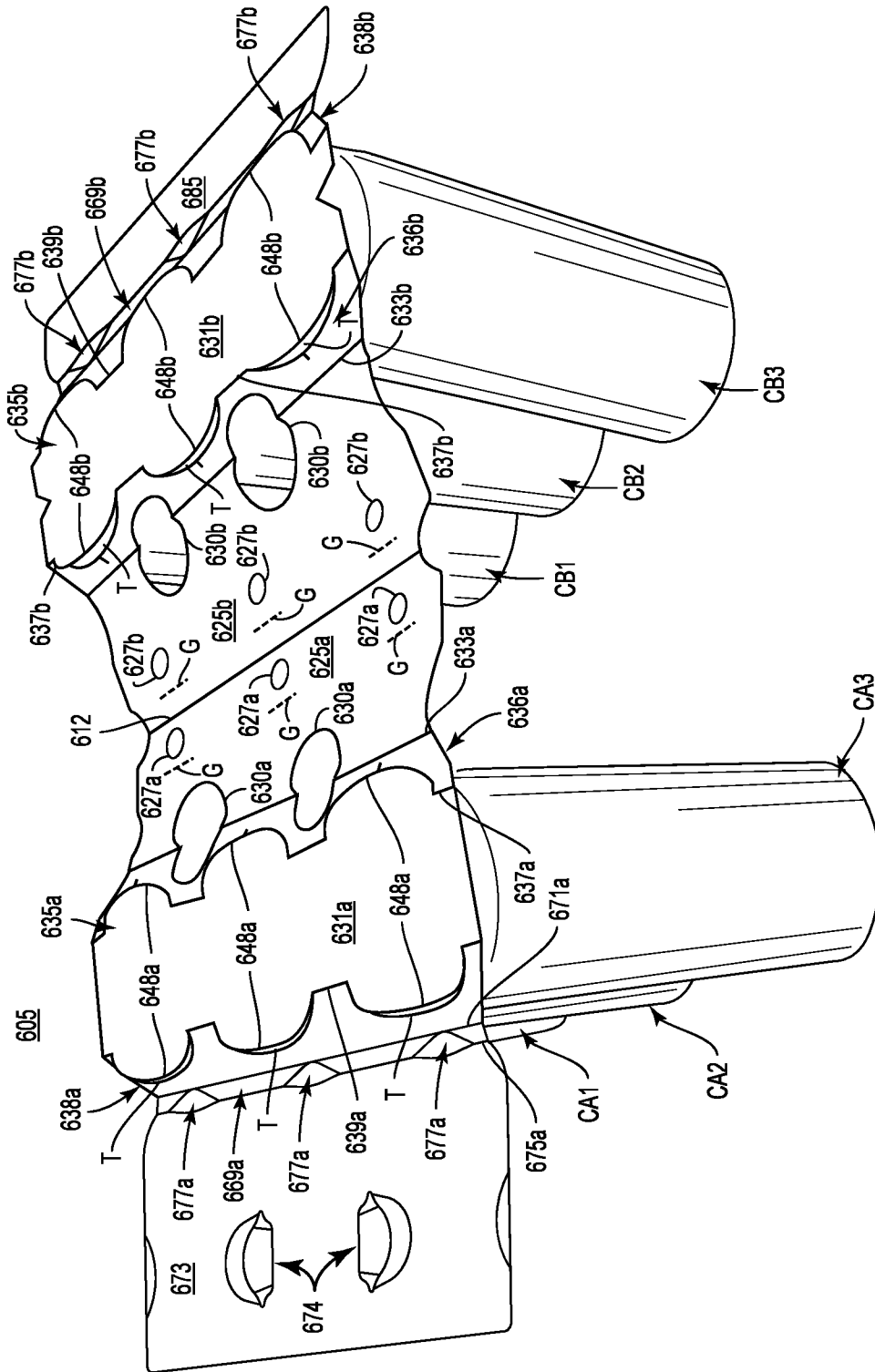

FIG. 25

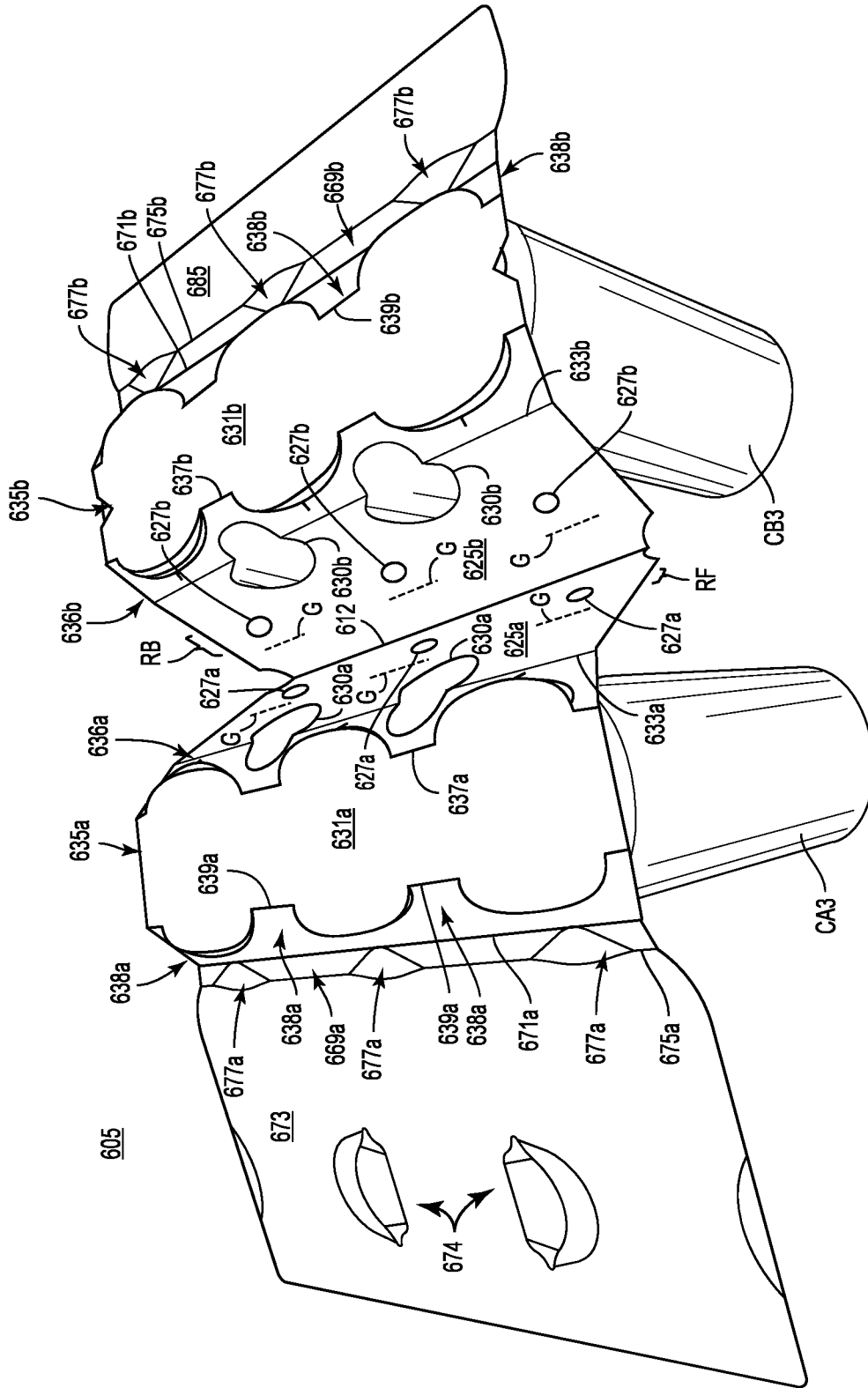

FIG. 26

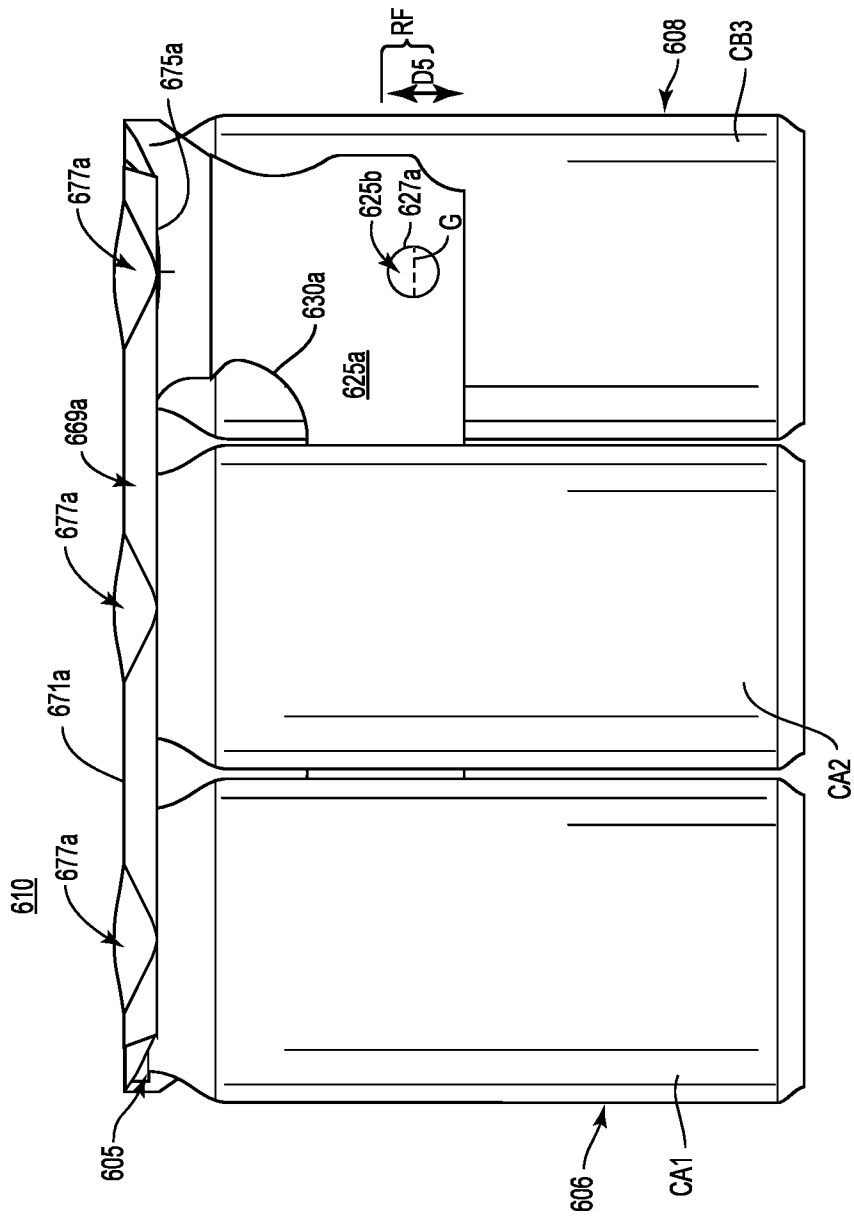

FIG. 27

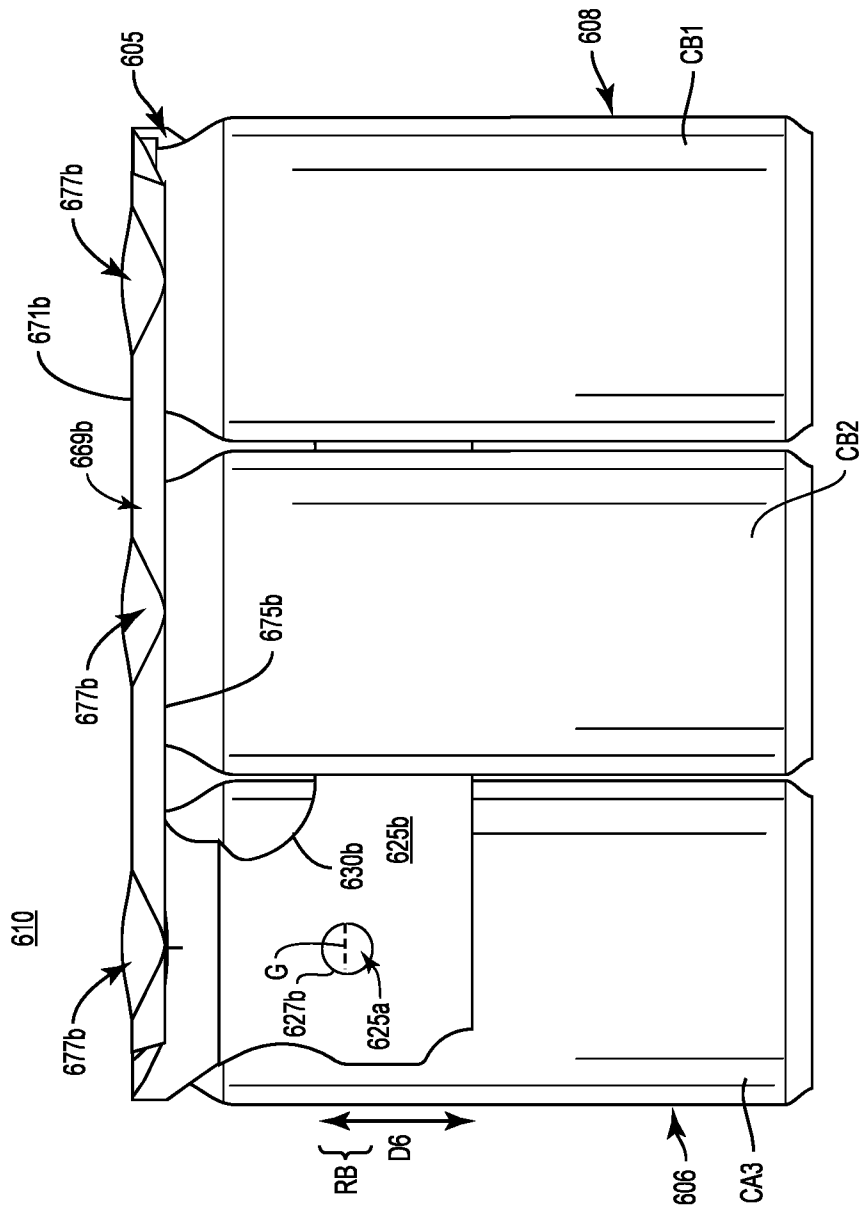

FIG. 28

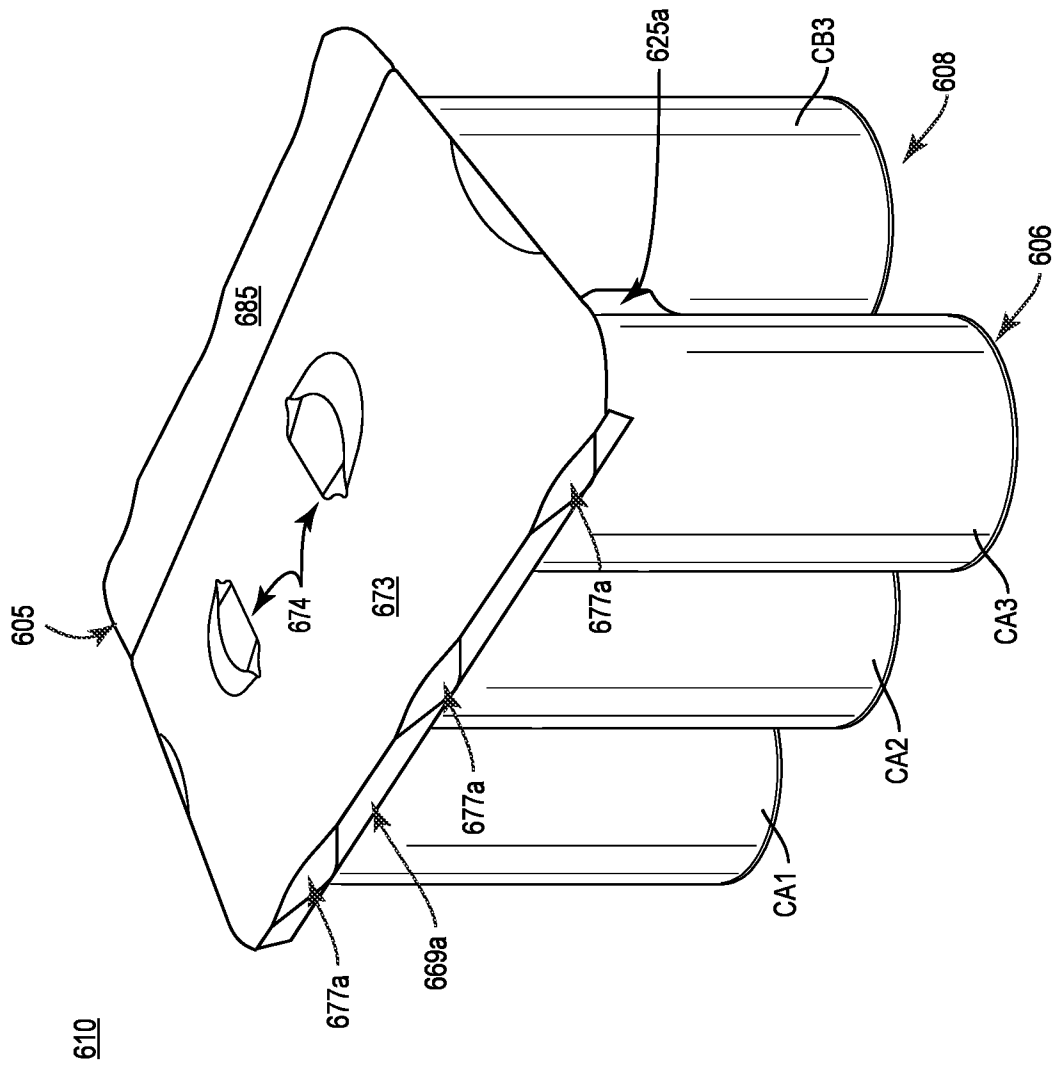

FIG. 29

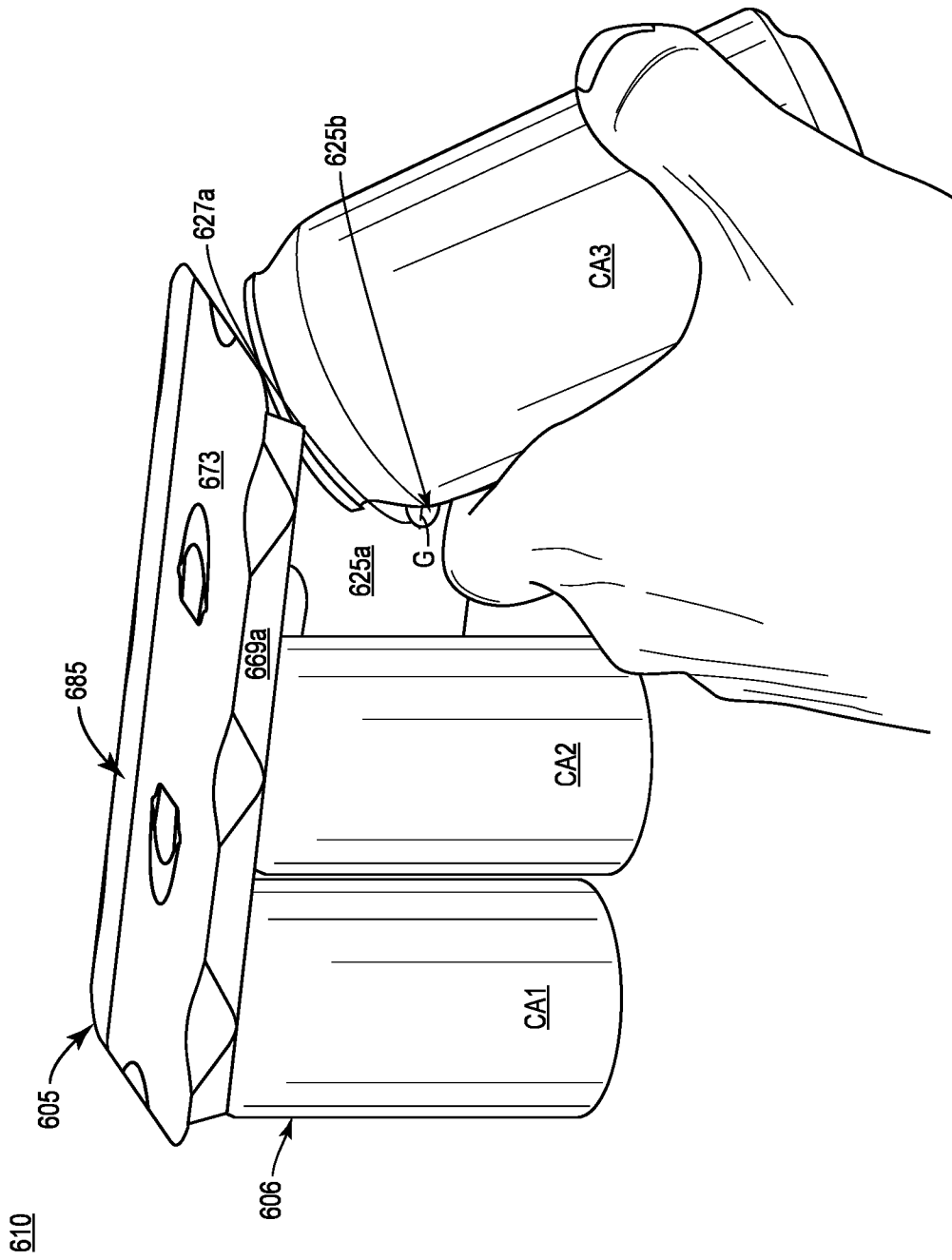

FIG. 30