



US00D376772S

United States Patent [19]

[11] **Patent Number: Des. 376,772**

Martin

[45] **Date of Patent: **Dec. 24, 1996**

[54] **TRUCK BODY**

Two sheet brochure by Unicell Limited entitled "You need a . . . Tough Body" Published by Applicant before Sep. 1993.

[75] Inventor: **Roger Martin**, Toronto, Canada

[73] Assignee: **Unicell Limited**, Toronto, Canada

Primary Examiner—James M. Gandy
Assistant Examiner—Cathron B. Matta
Attorney, Agent, or Firm—Fish & Richardson P.C.

[**] Term: **14 Years**

[21] Appl. No.: **28,766**

[22] Filed: **Sep. 22, 1994**

[57] **CLAIM**

[30] **Foreign Application Priority Data**

The ornamental design for a truck body, as shown and described.

Mar. 22, 1994 [CA] Canada 1994 0559

[52] **U.S. Cl.** **D12/96**

[58] **Field of Search** D12/96, 97; 296/180.1,
296/181, 183, 190

DESCRIPTION

[56] **References Cited**

FIG. 1 is a perspective view of one side of the design;

FIG. 2 is a right-hand side view of the design;

FIG. 3 is a top view of the design;

FIG. 4 is a front view of the design;

FIG. 5 is a rear view of the design; and,

FIG. 6 is a left-hand side view of the design.

U.S. PATENT DOCUMENTS

D. 322,419	12/1991	Camillieri	D12/96 X
4,201,415	5/1980	Suchanek	296/190
4,569,554	2/1986	Dodgen	296/183 X
5,131,714	7/1992	Evans, Sr. et al.	296/183
5,180,205	1/1993	Shoop	296/181

OTHER PUBLICATIONS

"Commercial Carrier Journal", Dec. 1992, p. 75, Hino Diesel Truck, STIC Library.

"Commercial Carrier Journal", Jun. 1992, p. 18, Freightliner Tractor, STIC Library.

The broken lines shown are for illustrative purposes only and form no part of the claimed design.

1 Claim, 5 Drawing Sheets

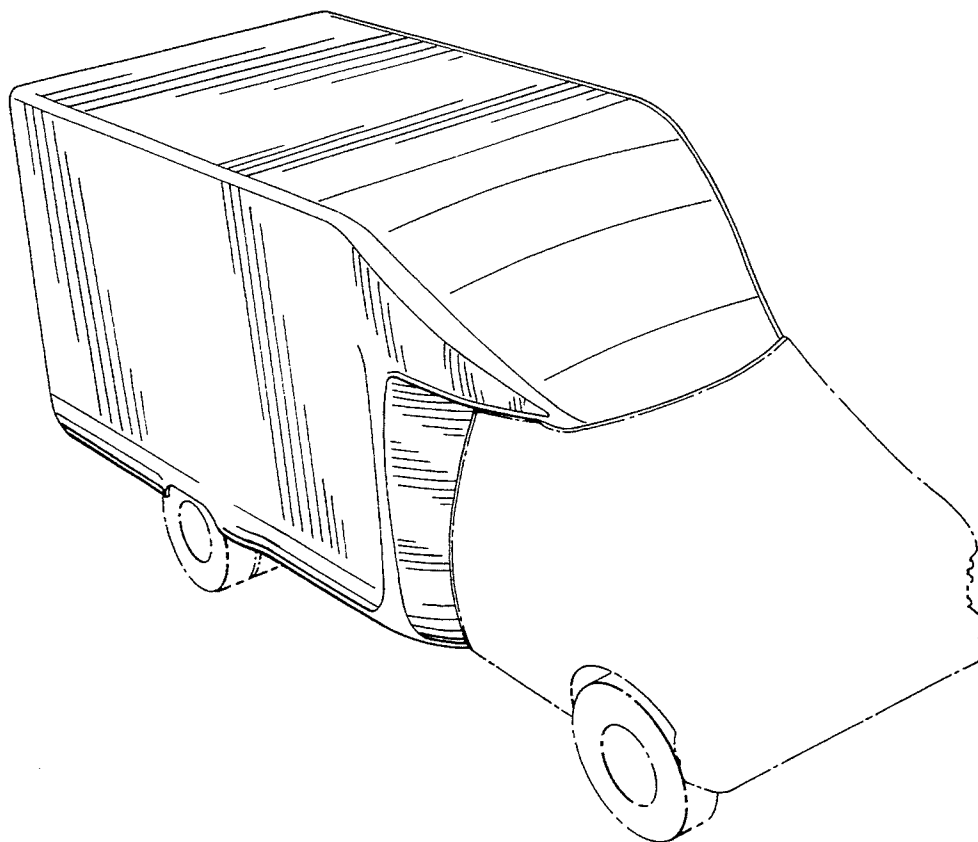

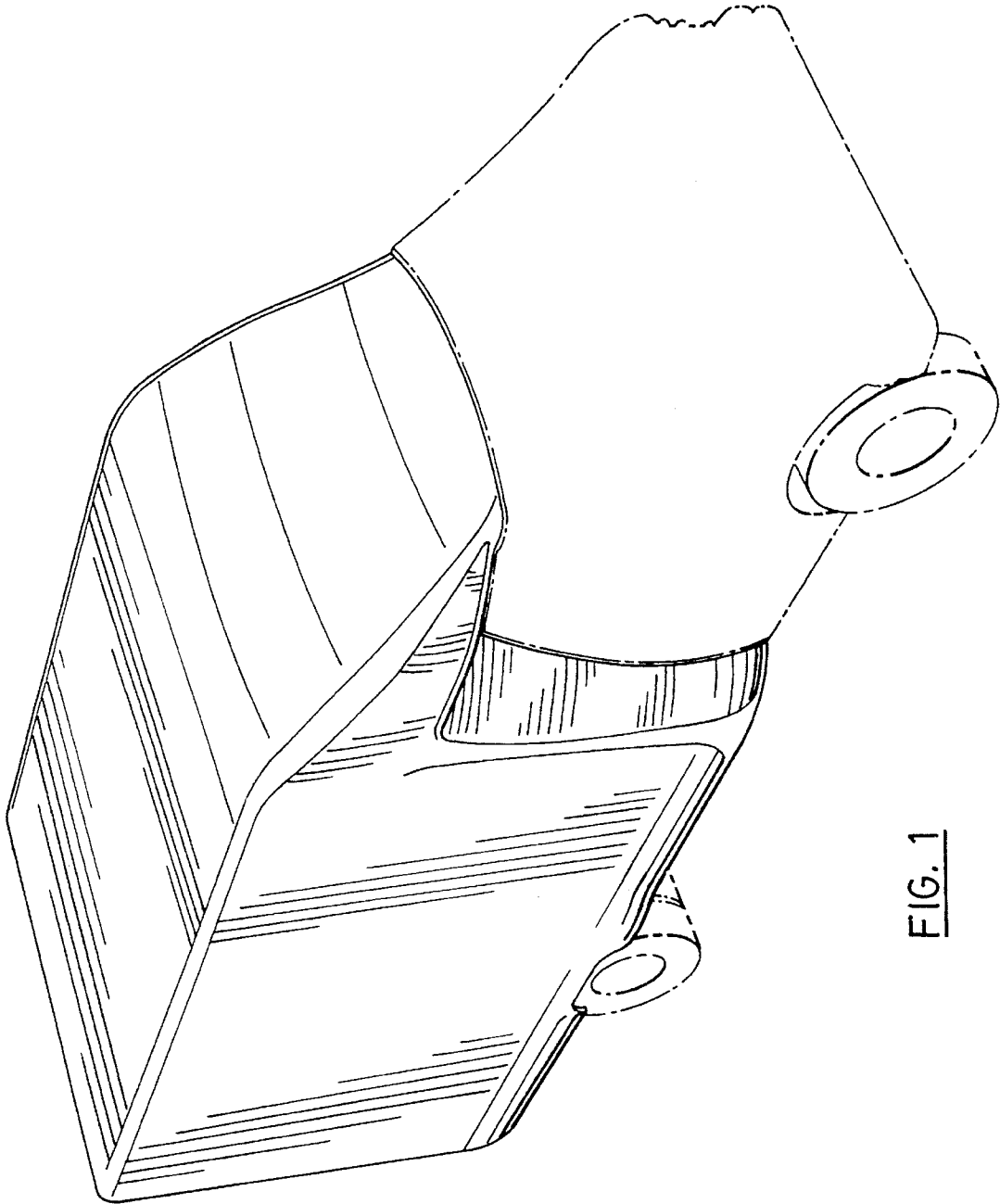

FIG. 1

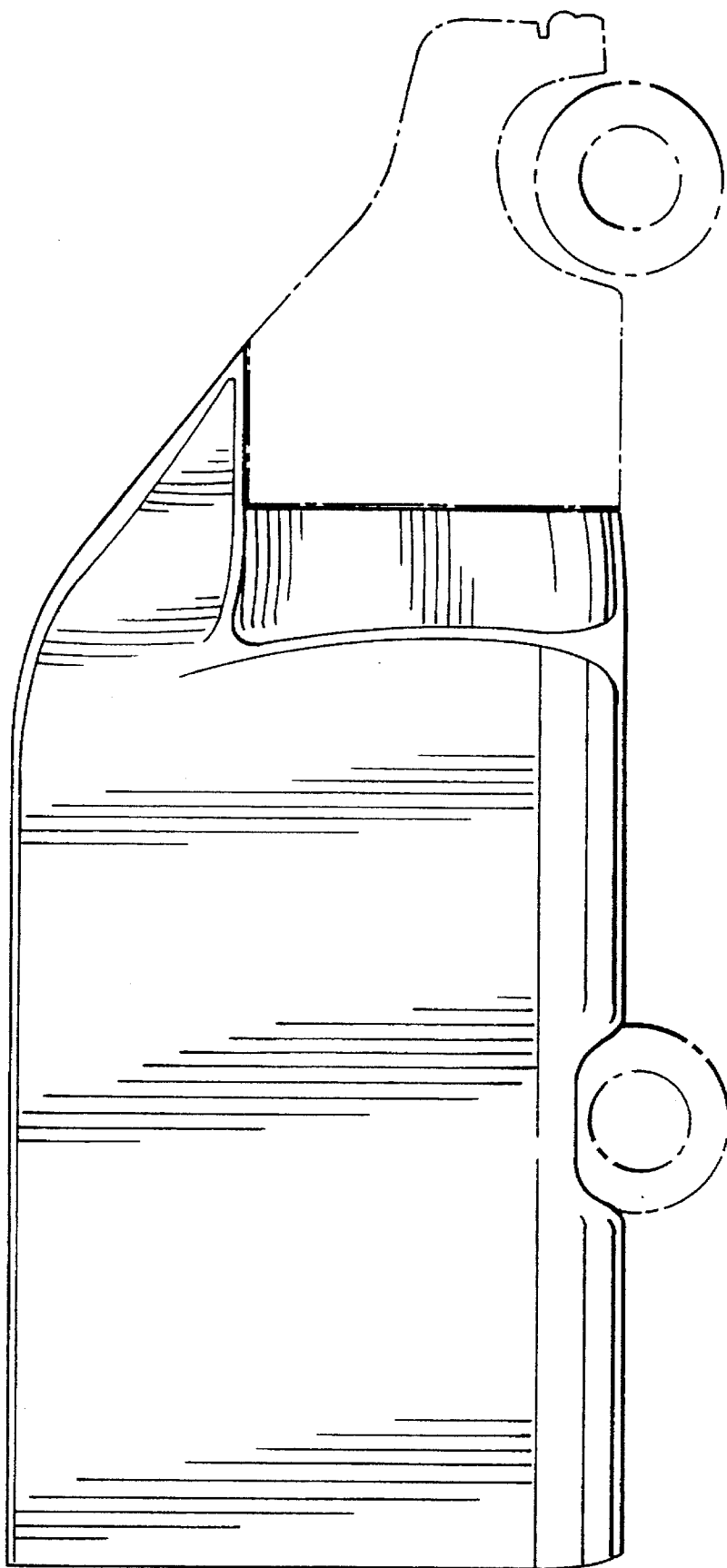

FIG. 2

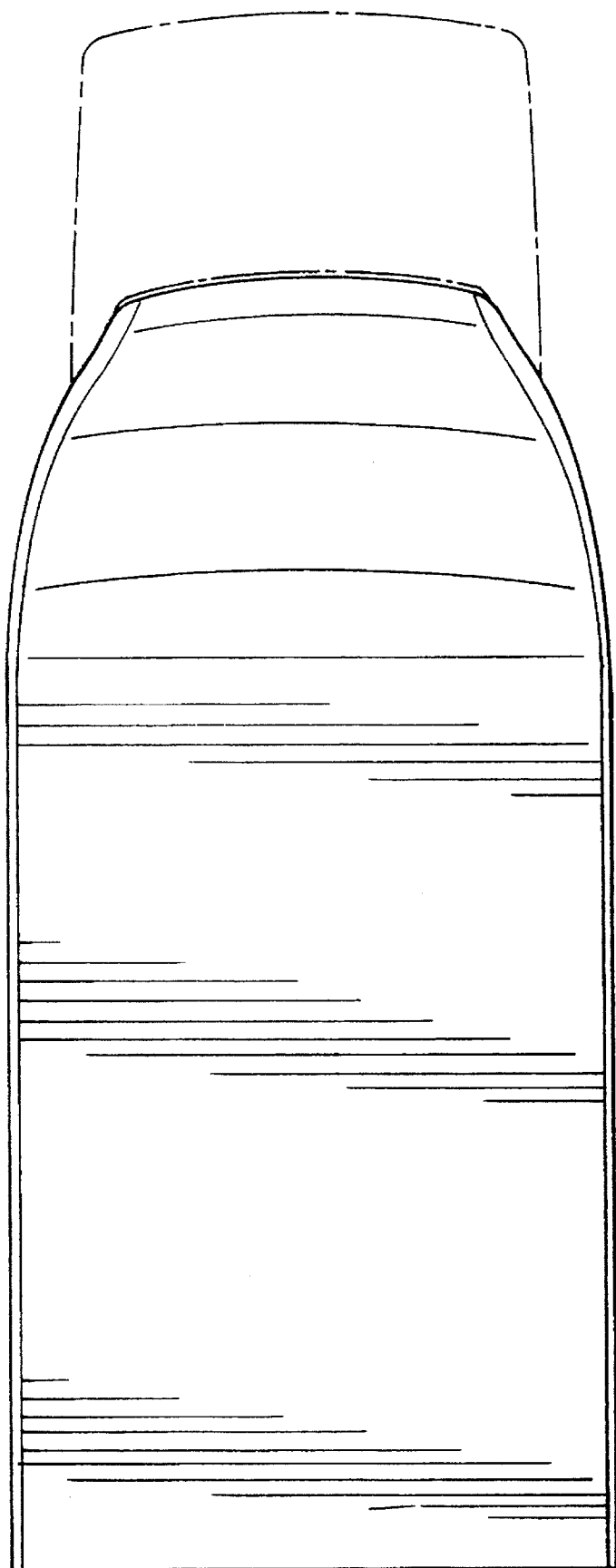

FIG. 3

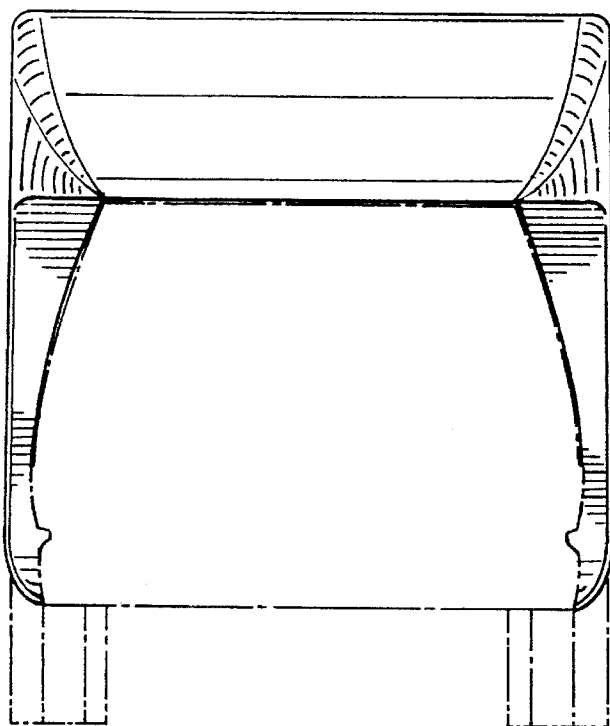

FIG. 4

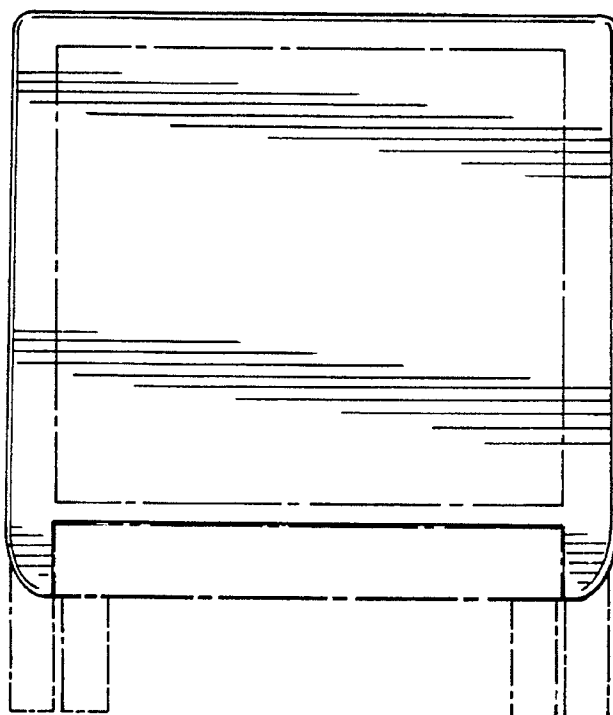

FIG. 5

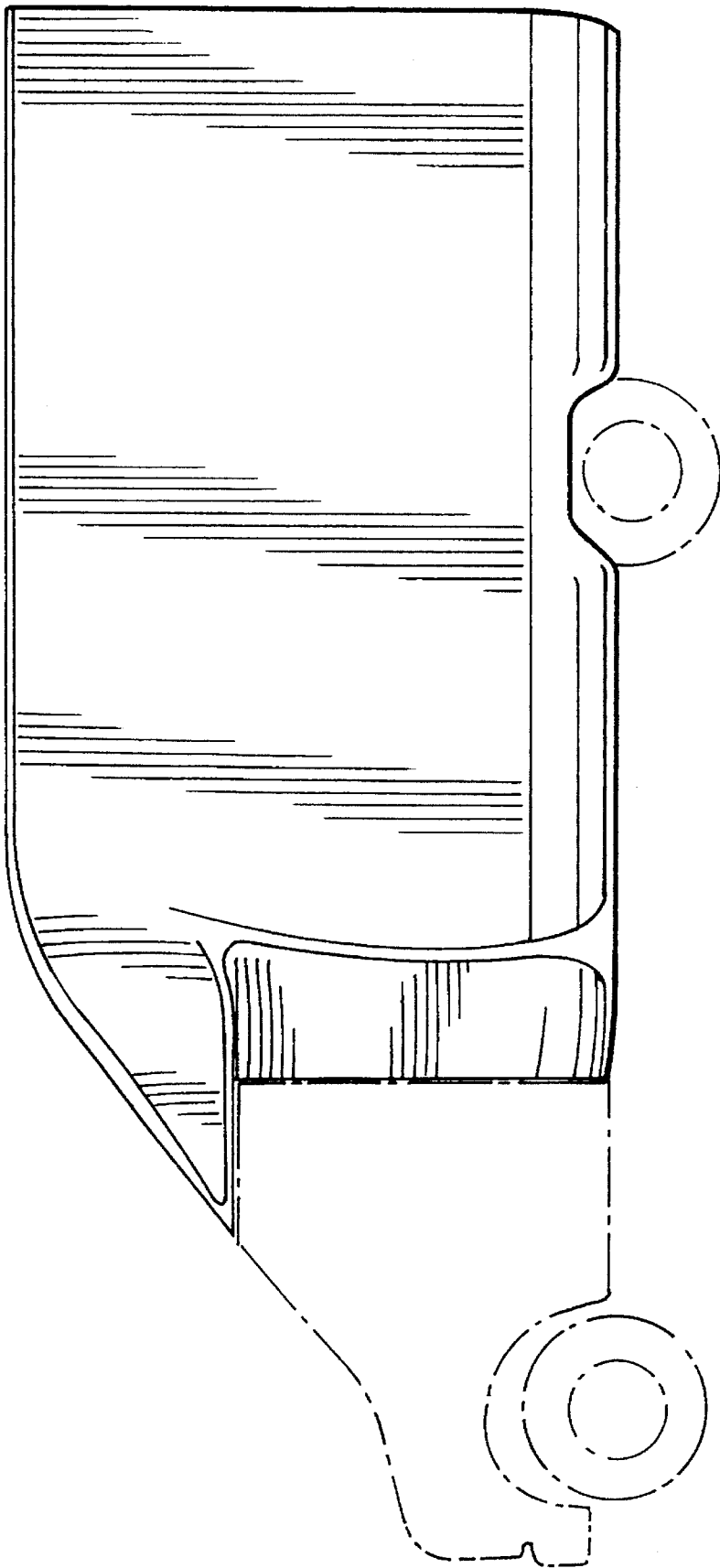

FIG. 6