

[72] Inventors **Robert G. Dale**  
**Tempe;**  
**Gary V. Fay, Scottsdale, Ariz.**  
 [21] Appl. No. **746,149**  
 [22] Filed **July 19, 1968**  
 [45] Patented **Jan. 26, 1971**  
 [73] Assignee **Motorola, Inc.**  
**Franklin Park, Ill.**  
**a corporation of Illinois**

3,389,301 6/1968 Siwko..... 307/136  
 3,402,302 9/1968 Coburn ..... 307/133  
 3,328,606 6/1967 Pinckaers..... 321/45DT  
 3,348,131 10/1967 Banks..... 321/45DT  
 3,474,293 10/1969 Siwko et al. .... 307/136X

*Primary Examiner*—Robert K. Schaefer  
*Assistant Examiner*—T. B. Joice  
*Attorney*—Mueller and Aichele

[54] **RELAY CIRCUITS EMPLOYING A TRIAC TO PREVENT ARCING**  
 13 Claims, 2 Drawing Figs.

[52] U.S. Cl..... **307/134,**  
 307/136, 317/11  
 [51] Int. Cl..... **H01h 33/59**  
 [50] Field of Search..... 307/134,  
 133, 136; 317/11.4; 302/252, 305A

[56] **References Cited**

**UNITED STATES PATENTS**

3,184,619 5/1965 Zydny..... 307/134  
 3,339,110 8/1967 Jones, Jr..... 307/134X

**ABSTRACT:** Disclosed is circuitry for controlling the flow of current from an AC source to a load and includes a bilateral semiconductor switch such as a semiconductor triac connected in parallel with the contacts of an electromechanical relay. The relay and triac are connected in series with the AC source and the load. Circuit means are connected between a gate electrode of the triac and circuit input terminals to which the AC source is connected and provides turn-on gate current for the triac prior to and during the closure of the electromechanical relay contacts to prevent effects of contact bounce. This circuit means also provides a sustaining or hold current to the triac subsequent to the opening of the relay contacts and thereby prevents contact arcing. The triac conducts before the relay contacts close and after the relay contacts open.

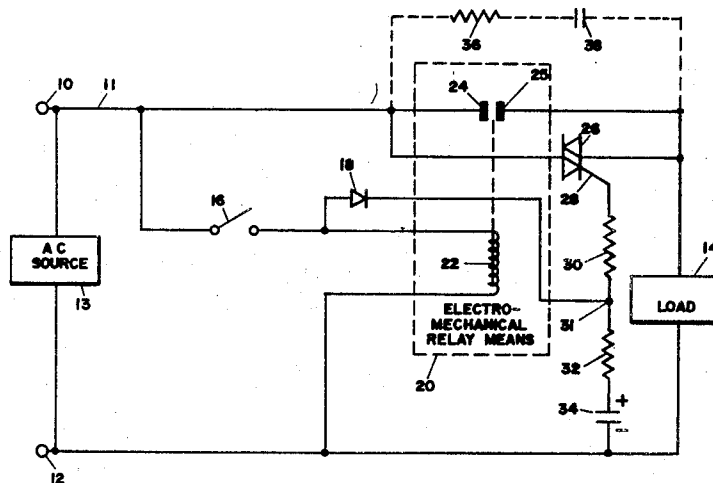

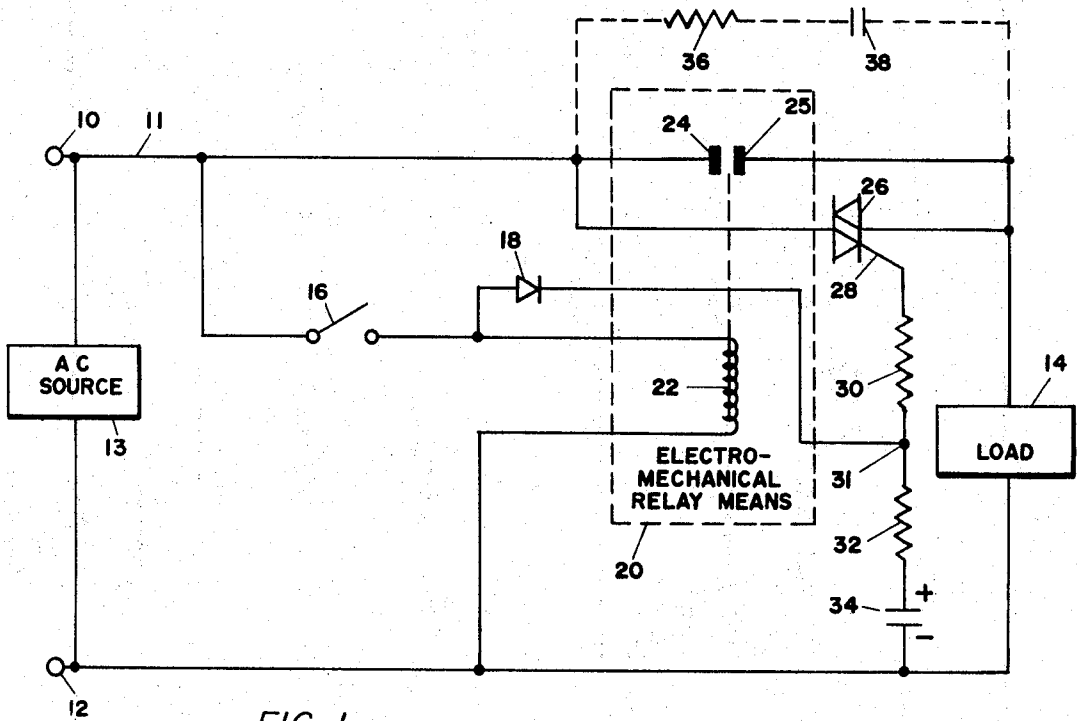

FIG. 1

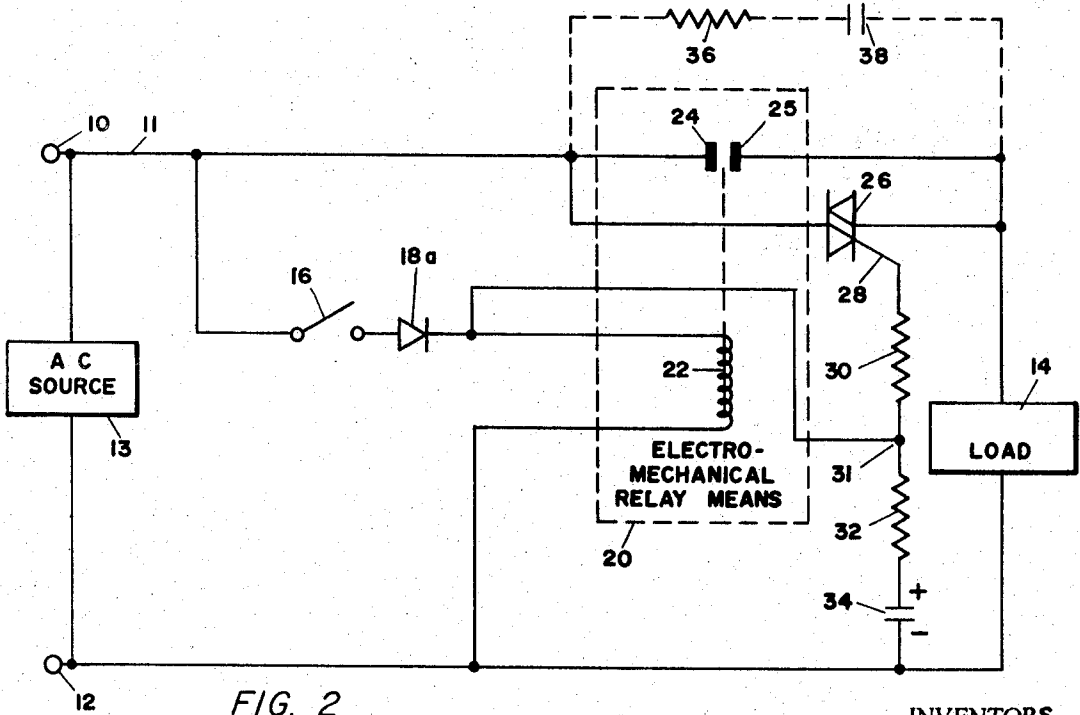

FIG. 2

INVENTORS  
**Robert G. Dale**  
BY **Gary V. Fay**  
*Mueller, Aichele & Rauner*

## RELAY CIRCUITS EMPLOYING A TRIAC TO PREVENT ARCING

The present invention relates generally to the switching of alternating current and more particularly to a system for switching large alternating currents on and off without relay contact arcing and the effects of contact bounce.

### BACKGROUND OF THE INVENTION

Prior art power control circuits have employed electromechanical relays of the type having a coil operative to close relay contacts when energized by alternating current. When the relay contacts open and close, there is a substantial amount of arcing due to the high electrical field between the contacts, and this arcing causes early contact failure because of the burning produced by the arcing. Because of the arcing, the size and expense of the relay contacts are much greater than would be required in the absence of such arcing. The arcing also generates noise and causes transients to be transmitted on the AC line. In addition, the contact bounce that takes place when the contacts close causes the contacts to wear and produces undesirable effects on the load.

### SUMMARY OF THE INVENTION

Accordingly, it is an object of the present invention to provide new and improved power control circuits which eliminate contact arcing in the electromechanical relay used therein.

Another object of the present invention is to provide a power control circuit in which the size and expense of the electromechanical relay contacts used therein have been greatly reduced for a given current rating.

A further object of the present invention is to provide a power control circuit having a long lifetime and in which the effects of contact bounce have been eliminated.

A further object of this invention is to provide a circuit of the type described which is simple and economical to build.

The present invention features an AC controlled bilateral conducting semiconductor switch which is connected in shunt with electromechanical relay contacts and which conducts prior and subsequent to relay contact closing and opening, respectively, to prevent contact arcing and the effects of contact bounce.

### DESCRIPTION OF THE DRAWINGS

FIG. 1 is a schematic diagram of one embodiment of the invention; and

FIG. 2 is a schematic diagram of an alternative embodiment of the invention. Corresponding components in FIGS. 1 and 2 share the same reference numerals.

### BRIEF DESCRIPTION OF THE INVENTION

Briefly described, the circuit embodying the present invention includes a bilateral semiconductor switch such as a triac connected in parallel with electromechanical relay contacts between an AC source and a load. A first circuit means is connected between circuit input terminals and a control electrode of the semiconductor switch for turning on the switch prior to the time that the relay contacts close, thereby preventing arcing and the effects of contact bounce upon contact closure. A second circuit means is connected to the first circuit means and provides a sustaining or holding current to the semiconductor switch after the relay contacts open to prevent arcing between the contacts upon the opening thereof.

### DETAILED DESCRIPTION OF THE INVENTION

Referring to the drawing, there is shown in FIG. 1 a power line 11 which interconnects a load 14 and a pair of input terminals 10 and 12. A mechanical switch 16 is connected between the input terminal 10 and electromechanical relay means 20 and is used to initiate switching action for connecting an AC source 13 to the load 14.

The electromechanical relay means 20 including a relay coil 22 and relay contacts 24 and 25 is electromechanically coupled to the AC line 11 as shown, and the coil 22 is connected to receive an energizing potential from the AC source 13 upon closure of electromechanical switch 16.

A diode 18 is connected between the switch 16 and a common junction 31 between first and second resistors 30 and 32. The diode 18 ensures that capacitor 34 charges in a positive direction as shown in the drawings. The first resistor 30 constitutes a first circuit means connected to a control or gate electrode 28 of the semiconductor switch 26 and provides turn-on gate current for the semiconductor switch 26. The resistor 32 and capacitor 34 constitute a second circuit means and provide sustaining or holding current to the semiconductor switch 26 to maintain switch 26 conducting after the relay contacts 24 and 25 have been opened by the deenergization of relay coil 22. The diode 18 provides a path for turn-on gate current through resistor 30 to the gate electrode 28 of the AC semiconductor switch 26. The bilateral semiconductor switch 26 is preferably a solid state device identified as a triac, and this triac can be triggered into conduction in either direction by positive or negative polarity signals on gate electrode 28. The triac structure is well known in the semiconductor art and the Motorola Type No. MAC2-4 may be used as switch 26 in FIGS. 1 and 2. The triac's semiconductor structure includes parallel PNPN conductive paths which are alternately driven into conduction upon positive and negative polarity signals respectively applied to the gate or control electrode 28 of the bilateral semiconductor switch 26. The gate region of the triac comprises P- and N-type subregions which are electrically connected to the gate electrode 28 and respond to the negative and positive polarity gate signals, respectively.

The resistor 30 has two functions in the circuit depending on whether the switch 16 has just been opened or whether the switch 16 has just been closed. If the switch 16 has just been closed, resistor 30 provides a path for gate current to flow into the gate electrode 28 as previously explained. If the switch 16 has just been opened, the resistor 30 provides a current path for the discharge of capacitor 34 to maintain semiconductor switch 26 conducting after the contacts 24 and 25 are opened by the electromechanical action of the relay means 20. At this time the capacitor 34 discharges through resistors 30 and 32 into the gate electrode of semiconductor switch 26 and into the load 14.

The electrical network consisting of resistor 36 and capacitor 38 controls the rate of change of voltage across the switch 26. This network insures that the switch 26 will not be triggered by rapid changes in voltage caused by closing or opening of contacts 24 and 25 or by voltage transients or surges on the power line 11.

### DESCRIPTION OF OPERATION

When mechanical switch 16 in FIG. 1 is closed to energize relay coil 22, there is a time delay between the initial energization of relay coil 22 and the closure of contacts 24 and 25. Similarly, there is a time delay between the deenergization of relay coil 22 and the opening of relay contacts 24 and 25 by well-known electromechanical relay action.

When the relay coil 22 is energized and in the absence of the semiconductor switch 26 and the associated circuitry according to the present invention, there is a bouncing of contacts 24 and 25 and an arcing therebetween caused by the high electric field between the open contacts 24 and 25. This bouncing chops the voltage waveform on power line 11, and the arcing and bouncing limits the contact lifetime.

In accordance with the present invention, the above problems associated with contact arcing and bounce are eliminated by the semiconductor switch 26 which draws turn-on gate current immediately upon the closure of switch 16. The semiconductor switch 26 immediately shorts out the relay contacts 24 and 25 and eliminates the high electric field otherwise present at these contacts. Thus, the contacts 24 and 25

close without contact arcing or effects of the contact bounce and there is no chopping of the line voltage. The initial load current is supplied through the semiconductor switch 26 until such time as the relay contacts 24 and 25 close. At this time, current flows through the relay contacts 24 and 25 to the load 14 even though there is a potential on the gate electrode 28 of the semiconductor switch 26. After switch 16 is closed, the capacitor 34 charges in a positive direction (as shown).

When the relay coil 22 is deenergized, the capacitor 34 discharges through resistors 30 and 32 to maintain the semiconductor switch 26 conducting during the opening of contacts 24 and 25, thus preventing arcing. Thus, the semiconductor switch 26 conducts prior to the closure of the contacts 24 and 25 and remains conducting after the contacts 24 and 25 are opened by the respective energization and deenergization of the relay coil 22. The capacitor 34 discharges into the gate 28 of the switch 26 and maintains switch 26 conducting for at least a few cycles after the contacts 24 and 25 open.

FIG. 2 illustrates an alternative embodiment of the invention wherein a half wave rectifier 18a is connected between the relay coil 22 and the mechanical switch 16. In this embodiment of the invention, the relay coil 22 is energized by a rectified half wave voltage which is also applied to the first and second circuit means at node 31 in the above-described resistance-capacitance network. In all other regards, the circuit shown in FIG. 2 operates in the manner identical to that described above with reference to FIG. 1.

Since there is no diode blocking between the capacitor 34 and the relay coil 22 in FIG. 2, the capacitor 34 will discharge through coil 22 at the same time it is discharging into the gate electrode 28 to maintain the triac 26 conducting. However, the second resistor 32 can be selected sufficiently large in value to limit the current flowing in relay coil 22 to a value insufficient to operate relay contacts 24 and 25. This requirement is not difficult to meet since gate current for the triac 26 is normally less than the value of current required to actuate the contacts 24 and 25.

The following is a table of resistance and capacitance values used in a circuit of a type described which has been built and successfully operated.

TABLE		Value
Component		
Resistor:		
30	----- kilohms	1.5
32	----- do	1.5
36	----- do	47
Capacitor:		
34	----- microfarads	10
38	----- do	0.1
Triac 26 (type)	----- Motorola MAC2-4	

The present invention may be practiced other than as specifically described above. For example, within the scope of the present invention, the bilateral semiconductor switch 16 could be replaced with any device (solid state or otherwise) which is responsive to a pulse of gate current to perform the relay contact shunting function described above. One such device may for example include two semiconductor controlled rectifiers (SCRs) connected in parallel with their gate electrodes connected together. The switch 26 may be fabricated in monolithic, hybrid or discrete component form within the scope of this invention. Accordingly, said invention is limited only by way of the following appended claims.

We claim:

1. Circuitry for controlling the flow of current from an AC source to a load including, in combination:

- a. relay contact means connected between a load terminal and input terminal means;
- b. electroresponsive means coupled between said input terminal means and said relay contact means for closing said relay contact means a given time after an input voltage is applied to said electroresponsive means;

c. a multilayer semiconductor switch connected in parallel with said relay contact means, said multilayer semiconductor switch having a gate region connected to a control electrode and responsive to negative and positive polarity signals to shunt said relay contact means;

d. first circuit means including a diode and a first resistor serially connected between said control electrode of said semiconductor switch and said input terminal means, said first circuit means applying a turn-on current to said semiconductor switch prior to the time said relay contact means close; and

e. second circuit means connected to said first circuit means and providing a current to said control electrode of said multilayer semiconductor switch to maintain conduction in said multilayer semiconductor switch after said relay contact means opens.

2. The circuitry defined in claim 1 wherein said second circuit means includes a second resistor and a capacitor connected to said first resistor, said capacitor discharging into said control electrode of said semiconductor switch to maintain said semiconductor switch conducting subsequent to the opening of said relay contact means.

3. The circuitry defined in claim 2 wherein said diode is connected between a common junction between said first and second resistors and said input terminal means.

4. The circuitry defined in claim 2 wherein said diode is connected in series with said relay means across said input terminal means, said relay means including a relay coil which is electromechanically coupled to said relay contact means for closing said relay contact means.

5. The circuitry defined in claim 2 wherein said relay means includes a relay coil which is connected across said input terminal means, said circuitry further including a diode connected between said input terminal means and said common junction between said first and second resistors.

6. The circuitry defined in claim 5 wherein said diode is connected directly between said common junction and said input terminal means.

7. The circuitry defined in claim 2 which further includes resistance-capacitance network means connected in shunt with said semiconductor switch and responsive to rapid changes in AC line voltage to prevent triggering of said semiconductor switch.

8. The circuitry defined in claim 7 wherein said resistance-capacitance network means consists of a resistor and capacitor connected in series across said semiconductor switch and across said relay contact means.

9. Circuitry for controlling the flow of current from an AC source to a load including, in combination:

- a. relay contact means connected between a first input terminal and a load terminal;
- b. electroresponsive means coupled between the first input terminal and said relay contact means for closing said relay contact means a given time after an input voltage is applied to said electroresponsive means;
- c. a semiconductor triac connected in parallel with said relay contact means and having a gate electrode for receiving gate current for turning on said semiconductor triac;
- d. a first resistor connected to the gate electrode of said semiconductor triac;
- e. a second resistor connected to said first resistor;
- f. charge storage means connected between said second resistor and a second input terminal, said means receiving a charge sufficient to sustain conduction in said semiconductor triac after an energizing voltage is removed from said electroresponsive means; and
- g. interconnecting circuit means connected between said first input terminal and a point intermediate said first and second resistors so that said first resistor limits the turn-on gate current to said semiconductor triac when the latter is turned on and said storage means discharges through said first and second resistors into the gate electrode of said semiconductor triac to sustain conduction

5

6

therein and prevent arcing in said relay contact means after an energizing voltage is removed from said electroresponsive means.

10. Circuitry defined in claim 9 wherein said semiconductor triac includes parallel PNPN conductive paths which are alternately rendered conductive upon the application of positive and negative polarity signals to said gate electrode of said triac.

11. The circuitry defined in claim 9 wherein said interconnecting circuit means includes a diode connected between said input terminal and said point intermediate said first and second resistors, so that said semiconductor triac and said capacitor are energized by a rectified voltage of one polarity.

12. The circuitry defined in claim 11 wherein:

a. said diode is connected in parallel with said electroresponsive means; and

b. said electroresponsive means includes an electromechanical relay including an inductor serially connected through a switch across a pair of input terminals for receiving an AC energizing voltage when said switch is closed.

13. The circuitry defined in claim 11 wherein said diode is connected between said input terminal and one end of an inductor in said electroresponsive means so that said electroresponsive means, said semiconductor triac, and said capacitor are all energized by a rectified energizing voltage.

15

20

25

30

35

40

45

50

55

60

65

70

75