



US 20080121321A1

(19) **United States**  
(12) **Patent Application Publication**  
Tiner et al.

(10) **Pub. No.: US 2008/0121321 A1**  
(43) **Pub. Date: May 29, 2008**

(54) **DIGITAL MEDIA DEVICE BILLFOLD**

**Publication Classification**

(75) Inventors: **Susan Dawn Tiner**, Arlington, TX (US); **Eddie Daniel Loven**, Euless, TX (US)

(51) **Int. Cl.**  
*A45C 11/00* (2006.01)  
(52) **U.S. Cl.** ..... **150/131**

Correspondence Address:  
**WINSTEAD PC**  
**P.O. BOX 50784**  
**DALLAS, TX 75201**

(57) **ABSTRACT**

A digital media device pocket for use in combination with a variety of receptacle assemblies. The digital media device pocket provides the user with visual, tactile, computer, and audio or power access to the digital media device while it is retained in the digital media device pocket. This permits the user of the receptacle assemblies to operate and stow the digital media device securely in the receptacle assembly while in operation, thereby enhancing the user's experience with both the digital media device and the receptacle assembly.

(73) Assignee: **TBAC Investment Trust**, Arlington, TX (US)

(21) Appl. No.: **11/525,576**

(22) Filed: **Sep. 22, 2006**

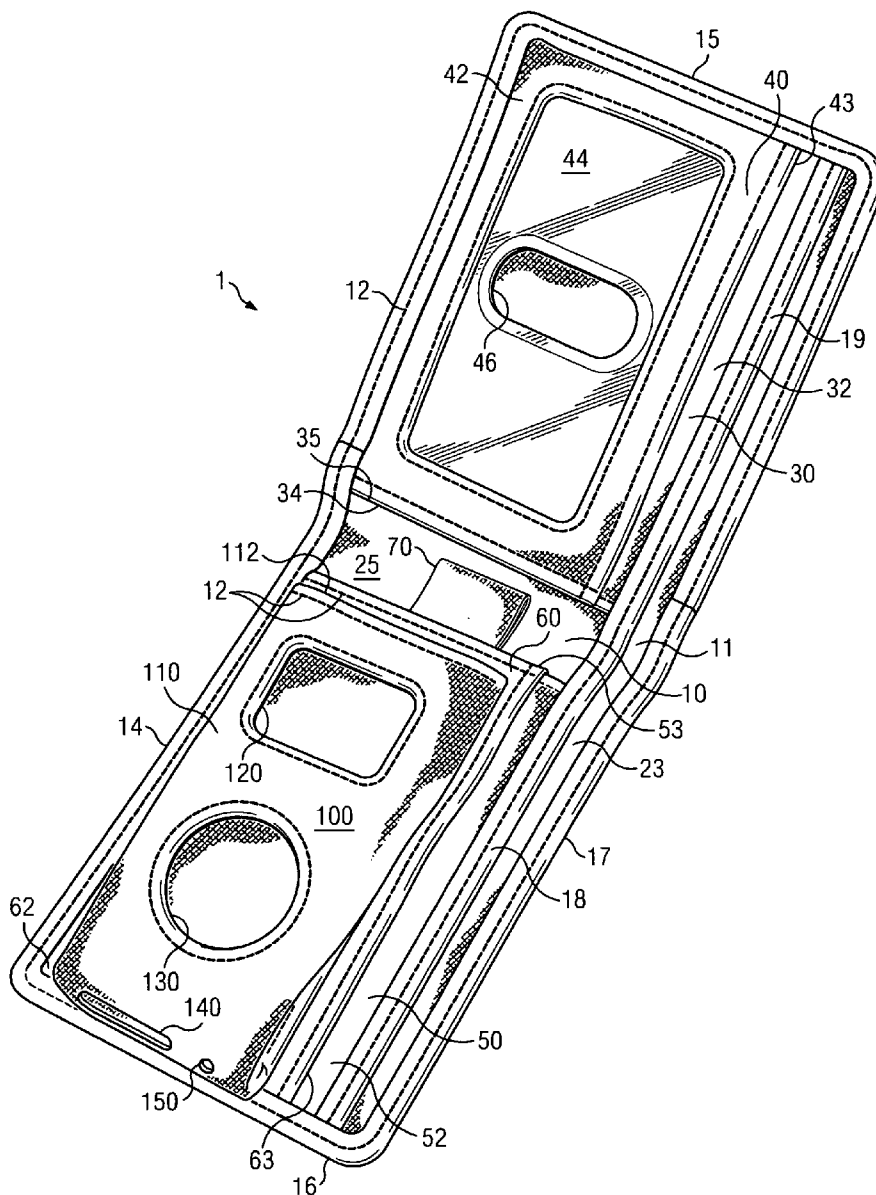

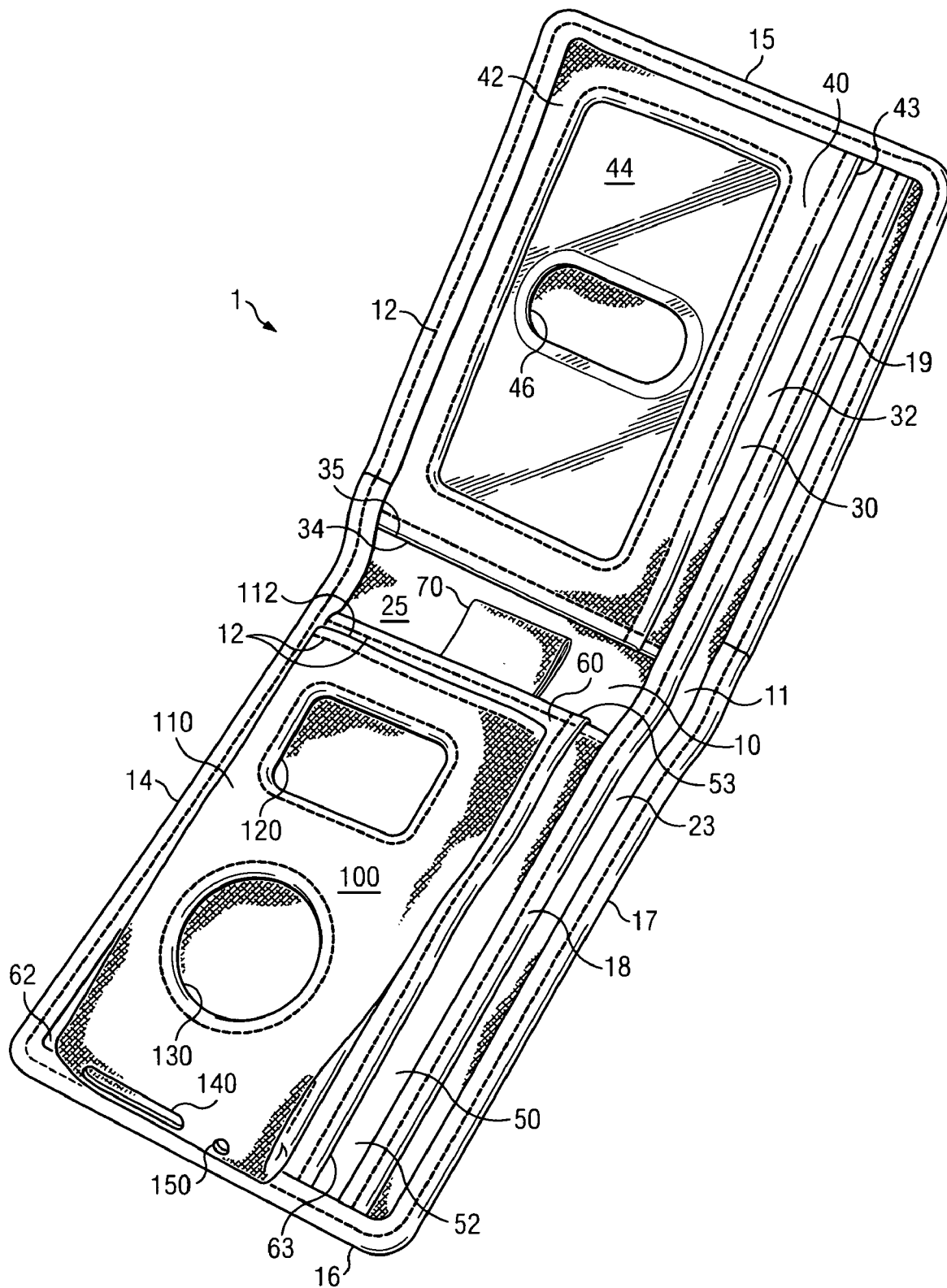

FIG. 1

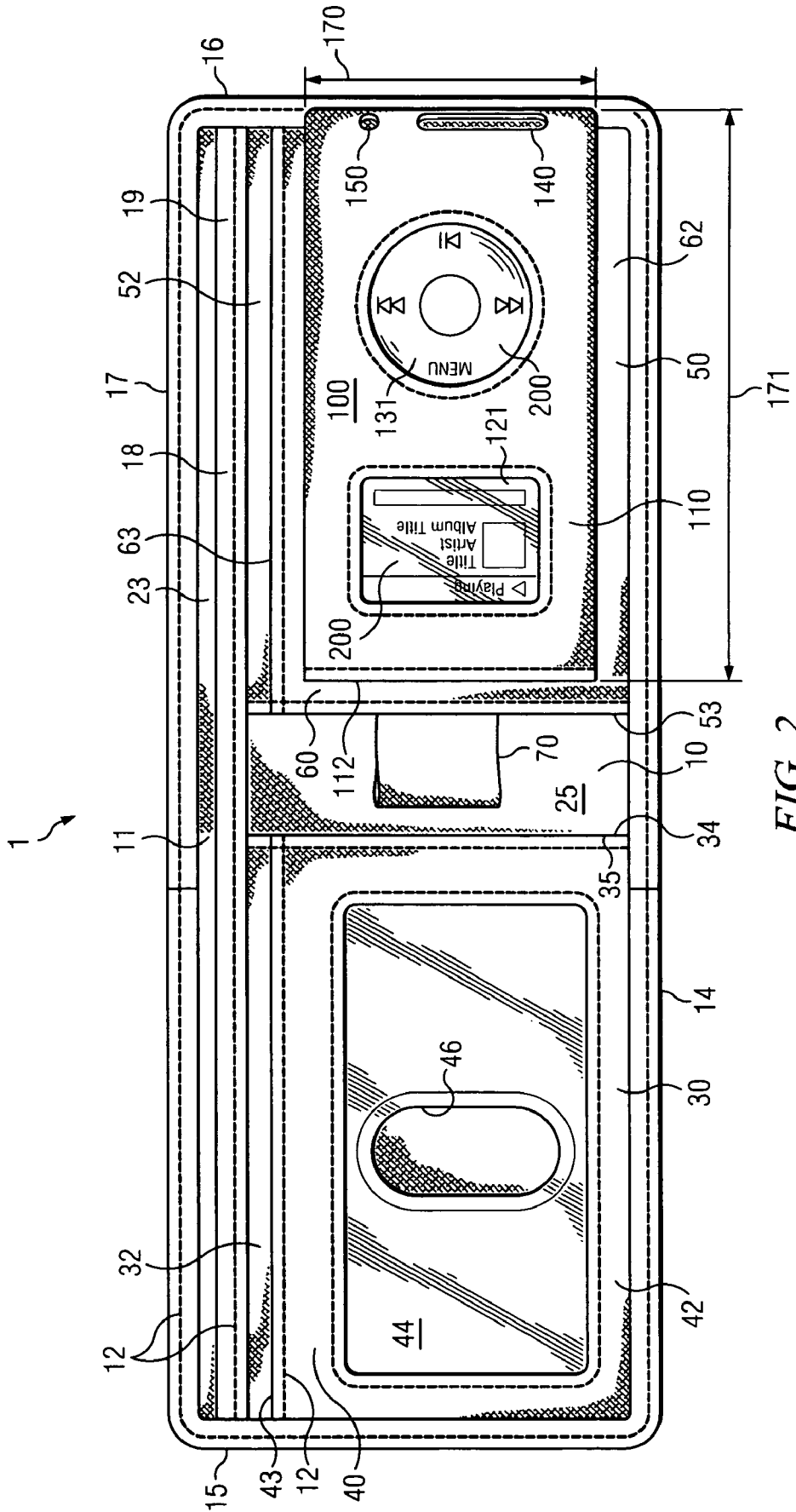

FIG. 2

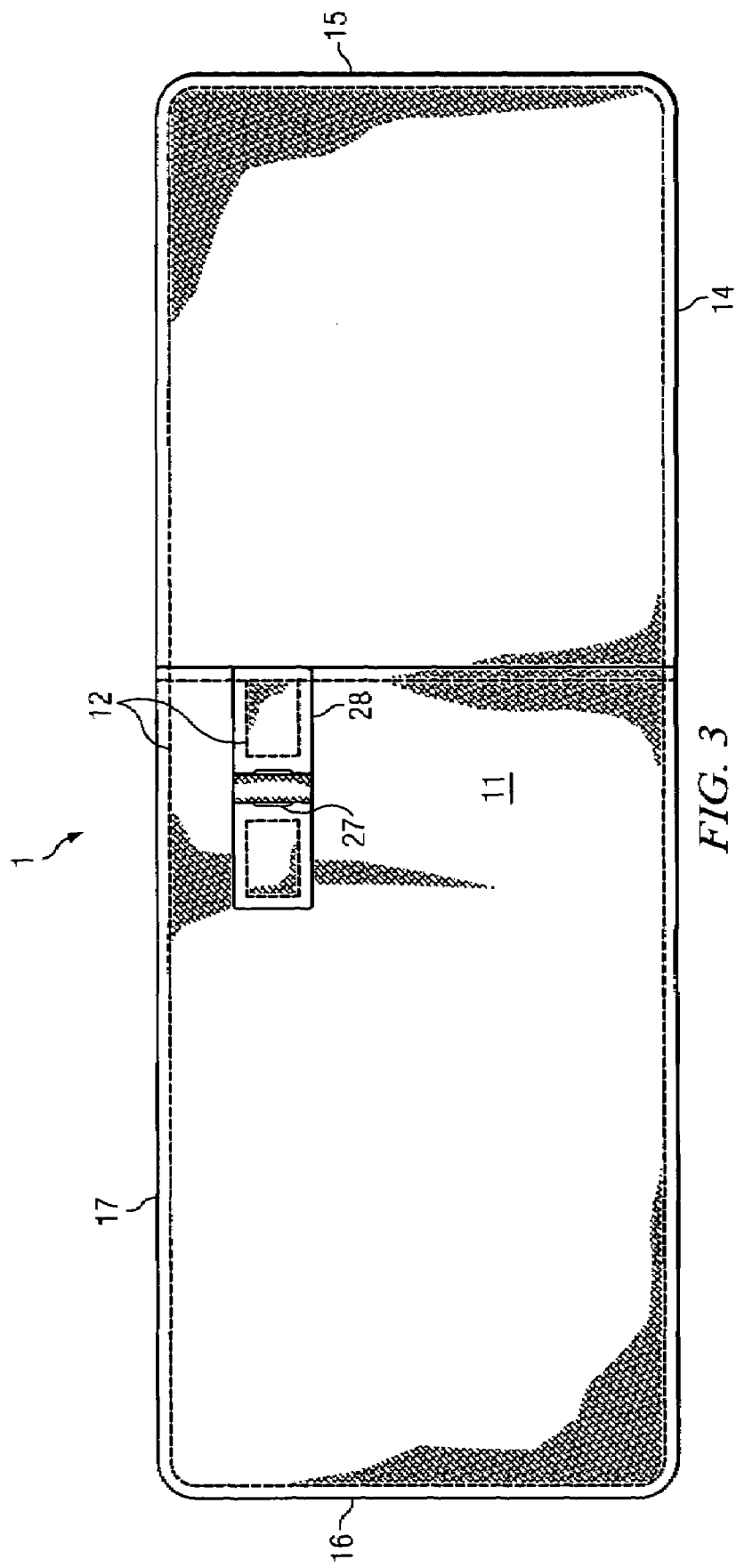

FIG. 3

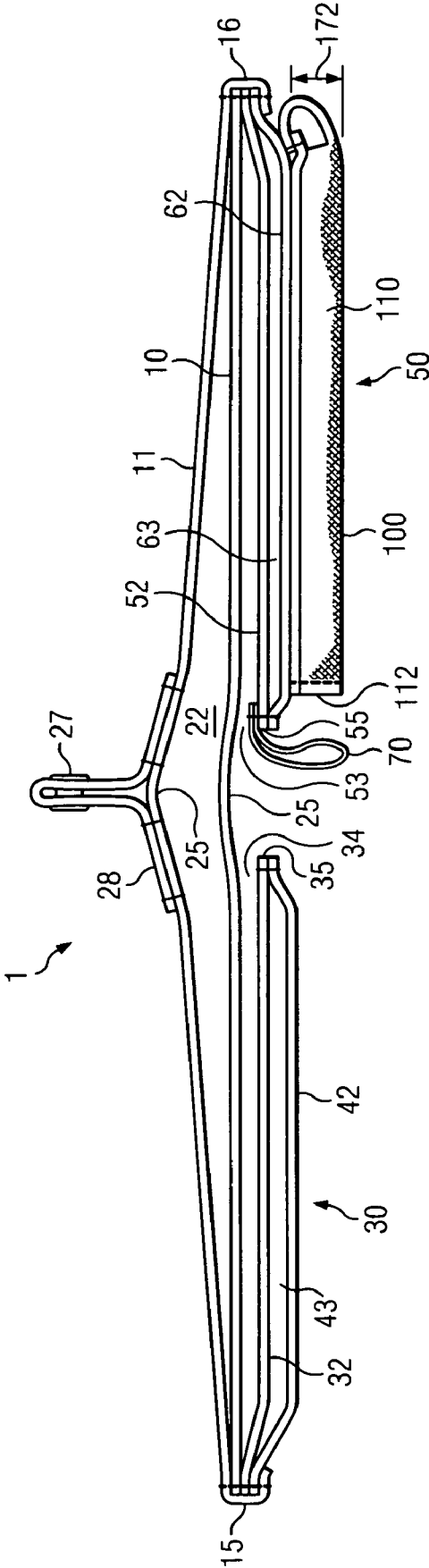

FIG. 4

**DIGITAL MEDIA DEVICE BILLFOLD**

CROSS REFERENCE TO RELATED APPLICATIONS

[0001] Not applicable.

STATEMENT REGARDING FEDERALLY SPONSORED RESEARCH OR DEVELOPMENT

[0002] Not applicable.

REFERENCE TO SEQUENCE LISTING, A TABLE, OR A COMPUTER PROGRAM LISTING COMPACT DISK APPENDIX

[0003] Not applicable.

FIELD OF INVENTION

[0004] Not applicable.

BACKGROUND OF THE INVENTION

[0005] The present invention relates generally to wallets and carrying cases. More particularly, the invention relates to a wallet or similar apparatus designed to carry, hold and protect a plurality of items. Even more particularly, the present invention relates a pocket used in a wallet or similar apparatus designed to house, hold, protect, carry, and permit use and access to a digital media device.

[0006] In today's society, individuals often carry multiple items on their person in or attached to their clothing. For example, many individuals carry billfolds or wallets, which maybe used to store a variety of items, including identification cards, credit cards, and coin and folding currency. Often, such billfolds are kept in the pockets of garments, but may also be retained in other ways such as being kept in a carrying bag or attached to the person's cloths via a clip or chain. In addition, many people often use and carry a number of electronic devices, such as cellular phones, digital media players, wireless communications equipment, and personal organizers, which are also stored in pockets in their garments or on their person via a carrying case. People often attempt to store these "digital media devices" in their billfolds or wallets not only for the sake of convenience of accessing and carrying the digital media device, but also to provide a layer of protection from damage during transportation and use. U.S. patent application Ser. No. 10/865,395 demonstrates such behavior by describing that a user of that device may wrap the device around an object to attempt to provide protection for the object. However, such ad hoc behavior does not properly protect or secure the digital media device in the billfold or wallet, potentially permitting harm to the device from dropping or crushing damage as the user manipulates the billfold or wallet. There is a need, therefore, to incorporate specific pockets or retainers in a wallet or billfold that retains the digital media device in the billfold or wallet and restricts it movement, thereby protecting it from damage.

[0007] Additionally, there is also a desire to allow the user to access the digital media device when coupled with the billfold or wallet. The user of the billfold or wallet may desire to access the digital media device in all manners necessary to operate and maintain the device at any given moment, such as to make a phone call, change a song being played, or read a message received. Access to the digital media device's many functionalities therefore must be unrestricted while at the

same time permitting the device to remain coupled to and protected by the billfold or wallet, even when the wallet or billfold is in an "open" state. It is desirable, therefore, while still maintaining coupling to the wallet or billfold, such access ports to permit visual, tactile, computer, power, and audio interaction with the digital media device. Such unrestricted access to the digital media device while still incorporated in the wallet or billfold would permit the user to interact with the device in the "open" position, choose the settings desired, and then return the wallet to the "closed" position while the device was still being used, thereby enhancing the user's overall experience of using the device and the wallet or billfold both separately and in combination.

[0008] Prior inventions describe retaining items in carrying cases for convenience and access. U.S. Pat. No. 5,778,954 discloses a wallet in which a pocket knife holder is incorporated in the design. U.S. Pat. No. 3,144,065 discloses a pocketbook with a support frame for carrying a transistor radio on the outside of the pocketbook.

[0009] What is needed then is a wallet that contains a pocket panel designed not only for removably receiving a digital media device but also allow the device to be conveniently carried, used, and interacted with while the wallet or billfold is being used in its traditional manner.

SUMMARY OF INVENTION

[0010] To accomplish the foregoing and related ends, the invention comprises the features as fully described and particularly pointed out in the claims. The description and the annexed drawings set forth the details of certain illustrative embodiments of the invention. These embodiments are indicative of but a few of the various ways in which the principles of the invention may be employed. Other objects, advantages, and novel features of the invention will become apparent from the detailed description of the invention when considered in conjunction with the drawings.

[0011] The more important features of the invention have been outlined in order that the detailed description may be better understood and that the present contribution to the art may be better appreciated. There are additional features of the invention that will be described that will form the subject matter of the claims.

[0012] Before explaining at least one embodiment of the invention in detail, it must be understood that the invention is not limited in application to the details of construction and to the arrangement of the components set forth in the description or illustrated in the drawings. The invention is capable of other embodiments and of being practiced and carried out in a variety of ways. It also must be understood that the phraseology and terminology employed are for the purpose of description and should not be regarded as limiting the invention.

[0013] Those skilled in the art will appreciate the conception upon which this disclosure is based and may readily utilize the disclosure as a basis for the designing of other structures, methods and systems for carrying out the several purposes of the present invention. It is important that the claims be regarded as including such equivalent constructions as they do not depart from the spirit and scope of the present invention.

[0014] While the various prior inventions do provide for storage, protection, or transport of particular items, these inventions do not provide for physical security of a digital media device. In addition, these inventions do not provide for

the ability to access the digital media device and interface with it once secured, such as by visual, tactile, computer, power, and audio interaction. Additionally, most of the prior inventions cited do not permit the active use of the digital media device by the user while the device is in the stored position, improving the user's experience of the device.

**[0015]** The wallet or billfold with a pocket specifically designed for use with a digital media device embodying the inventive principles have substantial advantages over the prior art. The present invention provides a flexible receptacle, such as a wallet or a billfold, but is not limited to such receptacles, that include a pocket designed to safely secure, protect, and hold a digital media device whether the wallet or billfold is in use or stowed on the person. Additionally, the wallet or billfold design of the present invention may be economically produced and is adaptable for creating a variety of models in accordance to various digital media device designs, thereby provide custom security, protection, and accessibility to the particular device while permitting ease of use and convenience to the user.

**[0016]** The pocket design that permits securing, protecting, and holding a digital media device that permits visual, tactile, computer, power, and audio interaction while stowed may be included in other receptacle assemblies, such as men's or women's wallets or billfolds of various sizes and shape, desk accessories, purses, handbags, minibags, coin purses, business card cases, agenda and personal organizers, or other assemblies where the user desires security and ease of accessibility of a digital media device.

**[0017]** These, together with other objects of the invention, along with the various features of novelty with characterize the invention, are pointed out with particularity in the claims forming part of this disclosure. For a better understanding of the invention, its operating advantages, and the specific objects attained by its uses, reference should be made to the accompanying drawings and descriptive matter in which there are illustrated preferred embodiments of the invention.

**[0018]** It should be understood that any one of the features of the invention may be used separately or in combination with other features. It should be understood that features which have not been mentioned may be used in combination with one or more of the features mentioned. Other systems, methods, features, and advantages of the present invention will be or become apparent to one with skill in the art up on examination of the drawings and detailed description. It is intended that all such additional systems, methods, features, and advantages be included with this description, within the scope of the present invention, and protected by the accompanying claims.

**[0019]** These and other objects, features, and advantage of the present invention, will be more readily apparent when considered in connection with the following detailed description of preferred embodiments of the invention, presented in conjunction with the drawings.

#### BRIEF DESCRIPTION OF DRAWINGS

**[0020]** The summary as well as the detailed of the preferred embodiment of the invention will be better understood when read in conjunction with the drawings. It should be understood that the invention is not limited to the precise arrangements and instrumentalities shown. The components in the drawings are not necessarily to scale; rather, the emphasis is placed upon clearly illustrating the principles of the present

invention. Moreover, in the drawings, similar or like reference numerals designate corresponding parts throughout several views.

**[0021]** The invention may take physical form in certain parts and arrangements of parts. For a more complete understanding of the present invention and its advantages, reference is made to the following descriptions taken in conjunction with the accompanying drawings, in which:

**[0022]** FIG. 1 is a perspective view of the interior of a wallet assembly depicted in an "open" configuration comprising a wallet with a flexible digital media device retention pocket according to the present invention;

**[0023]** FIG. 2 is a side view of the wallet of FIG. 1 assembly in the "open" configuration depicting the flexible digital media device pocket;

**[0024]** FIG. 3 is another side view of the wallet assembly of FIG. 1, as unfolded; and

**[0025]** FIG. 4 is a downward view from elevation of the wallet assembly of FIG. 1 depicting the flexible digital media device retention pocket in a partially extended position according to the present invention.

#### DETAILED DESCRIPTION OF THE INVENTION

**[0026]** The following discussion is presented to enable a person skilled in the art to make and use the invention. The general principles described may be applied to embodiments and applications other than those detailed below without departing from the spirit and scope of the present invention as defined by the appended claims. The present invention is not intended to be limited to the embodiments shown, but is to be accorded the widest scope consistent with the principles and features disclosed.

**[0027]** The present invention provides for a wallet or billfold with the pocket for use with a digital media device. A digital media device apparatus that converts works in digital form into a form whereby the images and sounds are visible or audible. Devices that currently perform some or all of these functions and are merely referenced as examples include the APPLE IPOD and APPLE IPOD nano, BLACKBERRY 7100 SERIES devices, and MOTOROLA RAZR and Q. In addition to the novel pocket that provides both security for the digital media device but also access by its user, additional organizational pockets are provided that permit the user to easily store, identify, and retrieve compartment contents. It should also be understood to one skilled in the art that the pocket design that permits securing, protecting, and holding a digital media device that permits visual, tactile, computer, power, and audio interaction while stowed included in the present invention may be included in other receptacles, such as other men's or women's wallets or billfolds of various sizes and shape, identification card holders, desk accessories, handbags, minibags, coin purses, business card cases, agenda/organizers, or other assemblies where the user desires security and ease of accessibility.

**[0028]** The principles of the present invention and their advantages are best understood by referring to FIG. 1 through 4. Although not shown, it should be understood that the pocket design of the present invention can be incorporated into a plethora of wallets or billfolds of various sizes and shape, desk accessories, handbags, minibags, coin purses, business card cases, agenda/organizers, or other assemblies. Referring to FIG. 1, a wallet assembly 1 is composed of a suitable material for manual use and direct contact with a person as well as being rugged enough for being carried on a

person in a pocket or another carrying device for extended periods of time. When unfolded, the wallet assembly 1 has a length for carrying dollar bills or other forms of bill fold currency. The wallet assembly 1 is foldable and can fit in normal sized pants pockets. For example, when unfolded or in the "open" position, the wallet assembly 1 may have a length of perhaps about 8 inches as well as a width of perhaps about 3¼ inches. As bi-folded or in the "closed" position, the wallet assembly 1 may have a size of perhaps about 4 inches length by about 3¼ inches width with a folded thickness of perhaps about ¾ inches, suitable for carrying in one's rear, front, or side pocket. While for illustrative purposes the wallet assembly 1 shown in the drawings is of a bi-fold type, it should be understood that the wallet assembly may take a tri-fold, non-folding, or other suitable assembly configuration to fit in a person's pocket or another carrying apparatus.

[0029] The wallet assembly 1 includes interior panel 10 and an exterior panel 11 which are sewn together with stitches 12 or otherwise suitably attached along a bottom edge 14 and end edges 15 and 16 to form a compartment 22 having an upper compartment opening, illustrated at 23, for receiving currency. The upper edge of the exterior panel 17 extends beyond upwardly of the upper edge of the interior panel 18 to allow the upper compartment opening 23 to be easily accessed. Lining materials may be provided to the interior facing sides of the exterior and interior panels 11 and 12, respectively, within the compartment 22 to supplement ease of use of the pocket and assist frictional retention of currency in the pocket. Lining materials may be provided to the exterior side of the exterior panel 11 relative to the compartment 22 to provide resistance to normal use and provide an overall fashionable appearance to the wallet assembly 1. Edging material, illustrated at 19, is suitably sewn along the upper edge of the interior panel 18. The edging material defines the edges of panels to which it is applied.

[0030] The wallet assembly 1 is a bi-fold type, providing a primary fold line 25, thereby defining a first and second section 30 and 50, respectively. First section 30 defines or extends to end edge 15 and second section 50 defines or extends to end edge 16. As seen in FIG. 1, when the wallet assembly 1 is folded along the primary fold line 25 so that it may be carried in one's pocket, the first and second sections 30 and 50, respectively, overlay each other and the wallet assembly 1 forms a "closed" position.

[0031] An eyelet 27, as can be seen in FIG. 3, is attached to the exterior panel 11 of the wallet assembly 1 by stitches 12 along the primary fold line 25 with an eyelet attachment 28 to permit the user to attach the wallet assembly 1 to their person or another object by threading the eyelet 27 with an attaching device or mechanism.

[0032] A first panel 32 is sewn to the interior panel 10 in the first section 30 alongside the end edge 15, the bottom edge 14, and the upper edge of the interior panel 18, to define a pocket having a first panel opening 34. A card receiving and viewing window combination pocket 40 is depicted by a card receiving/viewing window panel 42, further sewn to the first panel 32 alongside the end edge 15, the bottom edge 14, and the first panel opening edge 35, to define a pocket having a card receiving slot 43. The card receiving pocket viewing window 44 is preferably made from a transparent, translucent, or mesh material having generally rectangular dimensions; however, such shape is not meant to be limited in scope or design. The card receiving pocket viewing window 44 is sewn to the card receiving/viewing window panel via stitches 12. Addition-

ally, as can be seen in FIG. 2, the card receiving pocket viewing window 44 may incorporate a slot 46 to permit tactile interaction with the contents of the card receiving and viewing window combination pocket 40 while still contained therein.

[0033] As can be seen in FIG. 1, a second panel 52 is sewn to the interior panel 10 in the second section 50 alongside the end edge 16, the bottom edge 14, and the upper edge of the interior panel 18, to define a pocket having a second panel opening 53. For user convenience, a sleeve 70 is sewn to the second panel 52 at the second panel opening 53 to permit removable retainment and carrying of cylindrical apparatus, such as a scribing instrument. A card receiving pocket 60 is depicted by a card receiving panel 62, further sewn to the second panel 52 alongside the end edge 16, the bottom edge 14, and the second panel opening edge 55, to define a pocket having a card receiving slot 63.

[0034] In accordance with the present invention, a digital media device pocket 100 is formed by sewing using stitches 12 a digital media device panel 110 to the card receiving pocket 60 in such a manner as to form said pocket enclosure with the digital media device pocket opening edge 112 facing away from the end edge 16 and towards the primary fold line 25. The digital media device panel 110 contains several user accessibility windows, including but not limited to a digital media device visual window 120, a digital media device tactile interface window 130, a digital media device computer port access window 140, and a digital media device audio/power attachment window 150.

[0035] Illustrated in FIG. 2 is a digital media device 200 contained within the digital media device pocket 100. The digital media device 200, for the purpose of describing the detailed description and not in any way limiting the dimensions or form of the claimed invention, may have a uniform length of perhaps approximately 3½ inches, a uniform width of perhaps approximately 1⅓ inches, and a uniform thickness of perhaps approximately ¼ inch. Additionally, the digital media device 200 may contain several methods of user interaction with the device, including but not limited to a liquid crystal display with a diagonal cross-length of perhaps approximately 1½ inch for direct user visual interaction with the digital media device, a perhaps approximately 1 inch diameter circular tactile interface to allow for direct user manual interaction with the digital media device, a computer interface port for interaction with other digital devices with a perhaps approximate length of 1 inch and width of approximately perhaps ⅓ inch, and a circular port for audio or power attachment with a diameter of perhaps approximately ⅜ inch. Variations in physical size and configuration, technology used, and dimensions will vary with the technology used in the digital media device and are not in any way limiting the dimensions, form, or configuration of the claimed invention in that digital media device pocket 100 configuration is to reflect the digital media device 200 it is intended to retain. However, the physical size and configuration is limited as such to a digital media device 200 as would be physically capable of being retained in the previously described wallet assembly 1.

[0036] As seen in FIG. 1, the digital media device visual window 120 is a void rectangular shape with rounded corners reflecting the size and shape of the digital media device 200 visual interface screen, in this case perhaps approximately 1.5 inch in width and perhaps approximately 1 inch in length. Alternatively, the digital media device visual window 120, as



represented in FIG. 2, may contain a view window 121 made from a transparent, translucent, or mesh material. The view window 121, if present, is sewn to the digital media device panel 110 via stitches 12. As seen in FIG. 1, the digital media device tactile interface window 130 is a void circular shape reflecting the size and shape of a digital media device 200 tactile interface, in this case perhaps approximately 1 inch diameter. Alternatively, the digital media device tactile interface window 130, as shown in FIG. 2, may contain a touch window 131 made from a transparent or translucent material that is pliable in nature to permit user interaction with the digital media device 200 tactilely through the touch window 131. The touch window 131, if present, is sewn to the digital media device panel 110 via stitches 12. As seen in FIG. 1, the digital media device computer port access window 140 is a oblong circular shape reflecting the size and shape of a digital media device 200 computer access port, in this case perhaps approximately 1/8 inch in width and perhaps approximately 1 inch in length. The digital media device audio/power attachment window 150 is a circular shape reflecting the size and shape of a digital media device's audio or power interface connection port, in this case perhaps approximately 1/8 inch in diameter. Such shapes and dimensions, however, are not meant to be limited in scope or design and are reflective only of this description of this embodiment of the invention.

[0037] Further in accordance with the present invention, in order that a person may be able to easily secure the digital media device 200 within the digital media device pocket 100 in such a manner that it is easily removable, the digital media device pocket 100 is sized relative to the size of the digital media device 200 to provide a pocket width 170, length 171, and thickness 172, illustrated at FIGS. 2 and 4, which will fictionally or snugly or tightly hold or grip the digital media device 200 so that it does not fall out when the wallet assembly 1 is held in the open position in an atypical manner. For additional security of the digital media device 200 and increased reassurance to the user of the wallet assembly 1 while in the digital media device pocket 100, suitable fastening mechanisms known to one skilled in the art may be attached between the interior panel 10 or other parts of the wallet assembly 1 and the digital media device pocket 100 to provide cover or restraint or retention across the digital media device pocket opening edge 112. Moreover, when the wallet assembly 1 is folded into the "closed" position, the digital media device 200 is sandwiched between the first and second sections 30 and 50, respectively, for additional security and protection of the device. This sandwiched relationship may be maintained while either outside of an enclosed storage area like a pocket with suitable fasteners attached to the wallet assembly 1 that are known to one skilled in the art or by storing the wallet assembly 1 in a storage compartment that does not permit the wallet assembly 1 to obtain the "open" position. The width 170, length 171, and the thickness 172 of the digital media device pocket 100 is a little greater than the same physical dimensions of the digital media device 200 so that they are substantially equal to one another and permit frictional restraint and containment of the digital media device 200 internal to the digital media device pocket 100. The digital media device pocket 100 as well as the card receiving pocket 60 is desirably composed of a suitably coarse material which will accommodate or impart the desired frictional relation between the digital media device 200 and the digital media device pocket 100. The digital media device pocket 100 without the digital media device 200

contained therein may perhaps be about 3/12 inch in length, 1/8 inch in width, and 5/12 inch in thickness.

[0038] Thus, the wallet assembly 1 has the digital media device pocket 100 as provided so that a digital media device 200 may be securely and conveniently carried by a person.

[0039] Although the invention has been described with reference to specific embodiments, these descriptions are not meant to be construed in a limiting sense. Various modifications of the disclosed embodiments, as well as alternative embodiments of the invention will become apparent to persons skilled in the art upon reference to the description of the invention. It should be appreciated by those skilled in the art that the conception and the specific embodiment disclosed may be readily utilized as a basis for modifying or designing other structures for carrying out the same purposes of the present invention. It should also be realized by those skilled in the art that such equivalent constructions do not depart from the spirit and scope of the invention as set forth in the appended claims.

[0040] It is therefore, contemplated that the claims will cover any such modifications or embodiments that fall within the true scope of the invention.

What is claimed is:

1. A digital media device pocket for use with a receptacle assembly for retention of a digital media device, the digital media device pocket comprising:

a digital media device panel, wherein the panel is fixedly attached to the receptacle assembly forming a digital media device pocket, wherein the digital media device panel further comprises:

a digital media device visual window,  
a digital media device tactile interface window,  
a digital media device computer port access window, and  
a digital media device audio/power attachment window.

2. The digital media device pocket as in claim 1, wherein the receptacle assembly includes receptacle assemblies belonging to one of the group consisting of wallets, billfolds, identification card holders, desk accessories, purses, handbags, minibags, coin purses, business card cases, and agenda and personal organizers.

3. The digital media device pocket as in claim 1 wherein the digital media device panel is made of man-made materials.

4. The digital media device pocket as in claim 1 wherein the digital media device panel is made of a transparent material.

5. The digital media device pocket as in claim 1 wherein the digital media device visual window further comprises a transparent, translucent, or mesh view window.

6. The digital media device pocket as in claim 5 wherein the view window is made of a man-made material.

7. The digital media device pocket as in claim 1 wherein the digital media device tactile interface window further comprises a transparent or translucent touch window.

8. The digital media device pocket as in claim 7 wherein the touch window is made of a man-made material.

9. The digital media device pocket as in claim 1 further comprising means for securing said pocket closed.

10. In combination, a receptacle assembly including a plurality of sections, means for folding said receptacle assembly so that said sections overlie each other, and pocket means on at least one said section, said pocket means being sized for retaining a digital media device.

11. The combination according to claim 10 wherein said pocket means is fixedly attached to one of said plurality of sections and said pocket means has a width, length, and

thickness substantially equal to the width, length, and thickness of a digital media device.

**12.** The combination according to claim **10** wherein said pocket means is made of man-made materials.

**13.** The combination according to claim **10** further comprising means defining card pockets on said sections.

**14.** In combination, a wallet having an interior panel and an exterior panel connected together along bottom and end edge portions of said wallet to define a compartment for currency and including a first and second sections extended between said end edge portions with said first section containing one of said end edge portions and said second section containing another edge portion, means of folding said wallet so that the first and second sections overlie each other, and means defining a pocket disposed on said interior panel in between said first section and said another end portion for frictionally receiving a digital media device.

**15.** The combination according to claim **14** wherein said pocket is fixedly attached to said interior panel to have a width equal substantially to a width of a said digital media device, a length equal substantially to a length of a said digital media device, and equal substantially to a thickness of a said digital media device such that the digital media device does not protrude from the pocket.

**16.** The combination according to claim **14** wherein said pocket means is made of man-made materials.

**17.** The combination according to claim **14** further comprising means defining card pockets on said sections.

**18.** In combination, a card holder having a panel with opposing front and rear sides, said means defining a pocket disposed on said front side for frictionally receiving a digital media device.

**19.** The combination according to claim **18** wherein said pocket is fixedly attached to said front side to have a width equal substantially to a width of a said digital media device, a length equal substantially to a length of a said digital media device, and equal substantially to a thickness of a said digital media device such that the digital media device does not protrude from the pocket.

**20.** The combination according to claim **18** wherein said card holder is made of leather.

**21.** The combination according to claim **18** wherein said pocket is made of leather.

**22.** The combination according to claim **18** further comprising means defining card pockets on said front side.

**23.** The combination according to claim **18** further comprising means defining card pockets on said rear side.

**24.** The combination according to claim **18** further comprising means for securing said pocket closed.

\* \* \* \* \*