

(19)
(12)

(KR)
(Y1)

(51) 。 Int. Cl.7
G02F 1/13

(45)
(11)
(24)

2003 11 01
20-0331861
2003 10 21

(21) 20-2003-0026156
(22) 2003 08 13

(73) () 614-4

(72) 915-1

(74)

:

가 :

(54)

2

3

4

5

6

7

4

6

가

10: 20:

30: 32:

40: 50:

52: 54:

54a: 54b:

56: 58;

가

(3) 1 (5) (1) (3) (1)
 (7) (7) (7) (5) (5)
 (G) 가 . , (7) .
 7) 가 , 가 (7) (G) (G) (G) (G) (G) (G)
 (9)가 . 1
 , 가 (7) (G)

(7)가 (G) (7) (G) (G) 가 가 (G) (7)

(G) (G) 가 가 (G) (G) (G) (G)

가

;

2 (20) (30) (10) (20) (G) (10) (32)

(32) (30) (40) (40)가 (40)

(G) (40) (32) (40) (32) (50)

(50) (52) () (50) (40) 가 (40) 3 (50)

(50) (52) (50) (40) (54) (54a) (54b) (54)가 (40)

(54b) (54) (54a) (52) (50) (54) 4 (50) (50) (G) (G) (50)

(50) 4 (prepreg)

, 가 , 가 (50)

(50) (56) (56) /
Ethylene), PFA(Perfluoroalkoxy) PEEK(Polyether Ether Ketone), PTFE(Poly Tetra Fluor
(G) 가 (G) 가 ,

(50) , 4 (40)
(G)

(50) 5 (G) (G) 가 (G)

(G) (G)

, 6 7 (40) (40) (G)
(50)

0) , 4 가 (50) (G) 가 (50) (G) 가 (G) (4
(G)

(50) 6 (58) (52) (40)
(58) (50) 가 (50) (52) (54)가
(54)

(50)가 (G) (50) 가 (G) , 6 7
(G)

(50)가 (G) (G)가 (G)
(G)

가

(57)

1.

1 2.

가

1 3.

2

1 4.

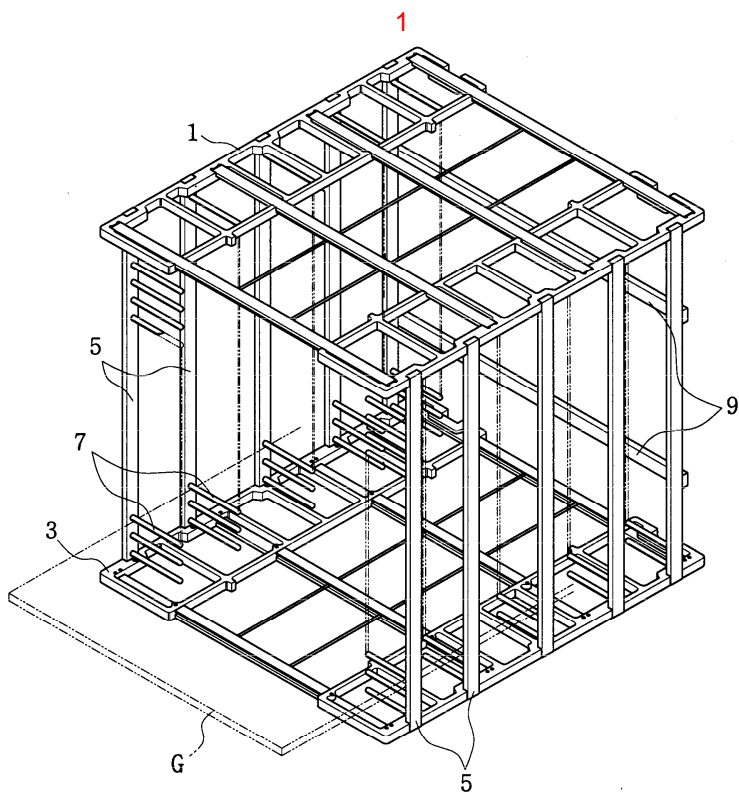

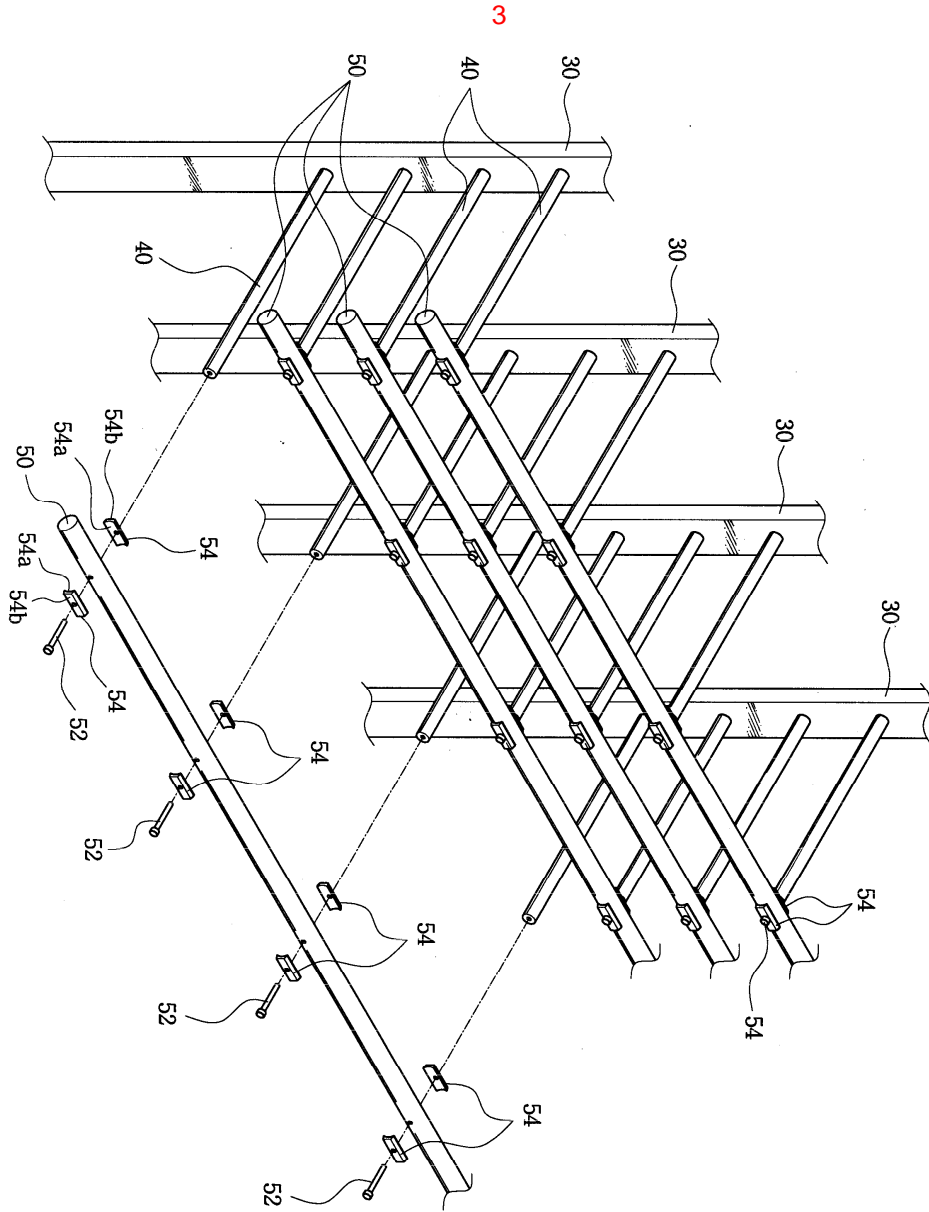

4

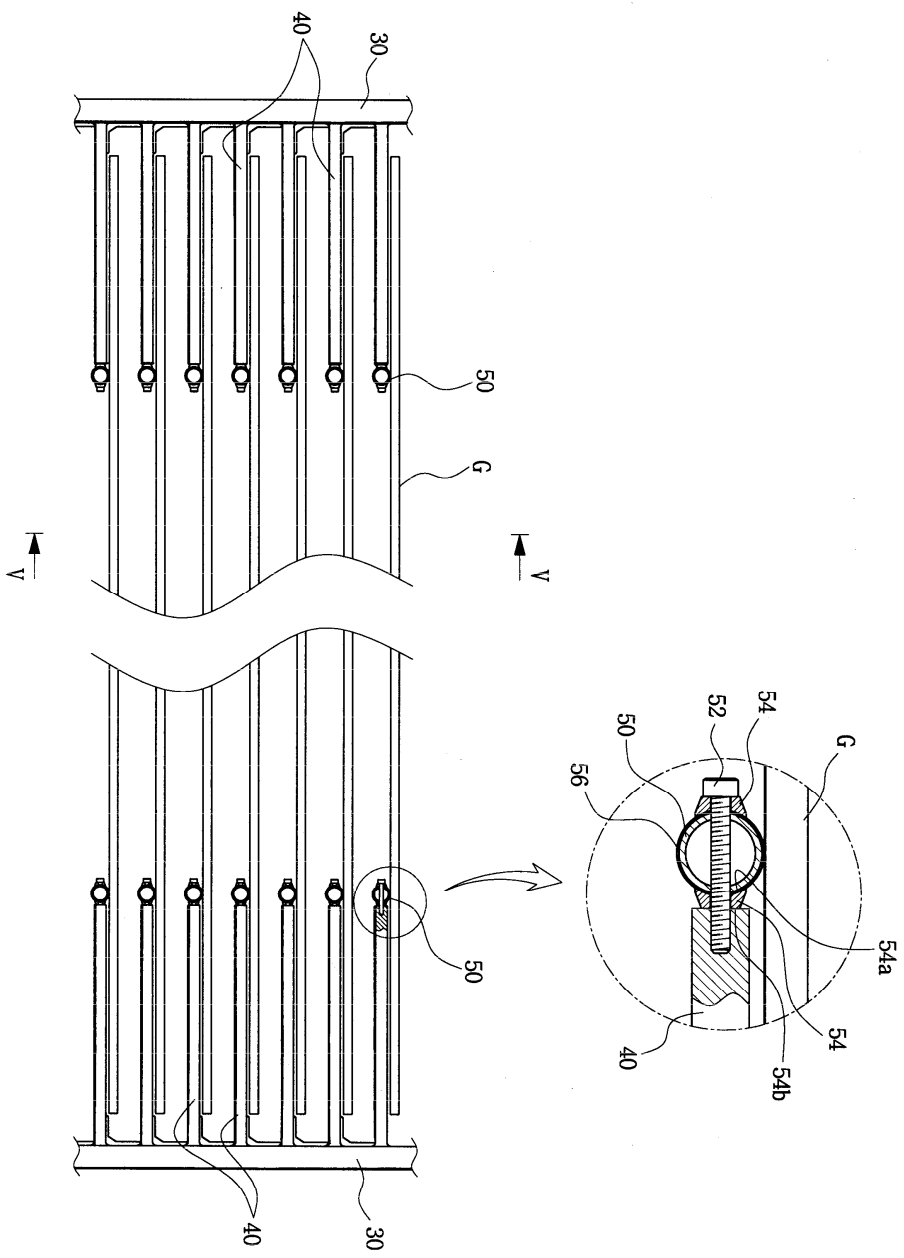

5

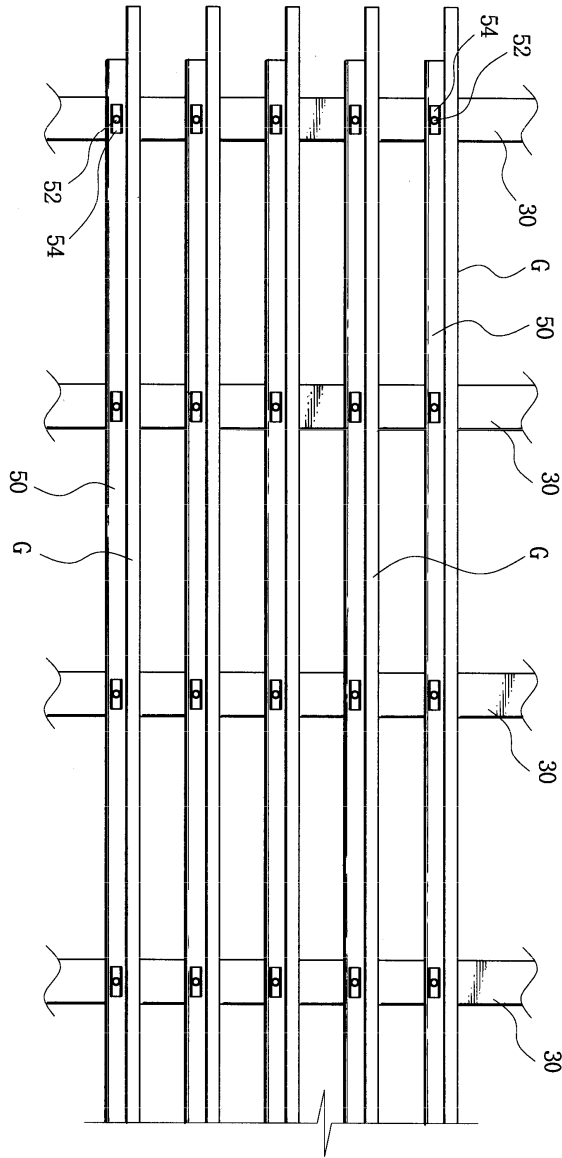

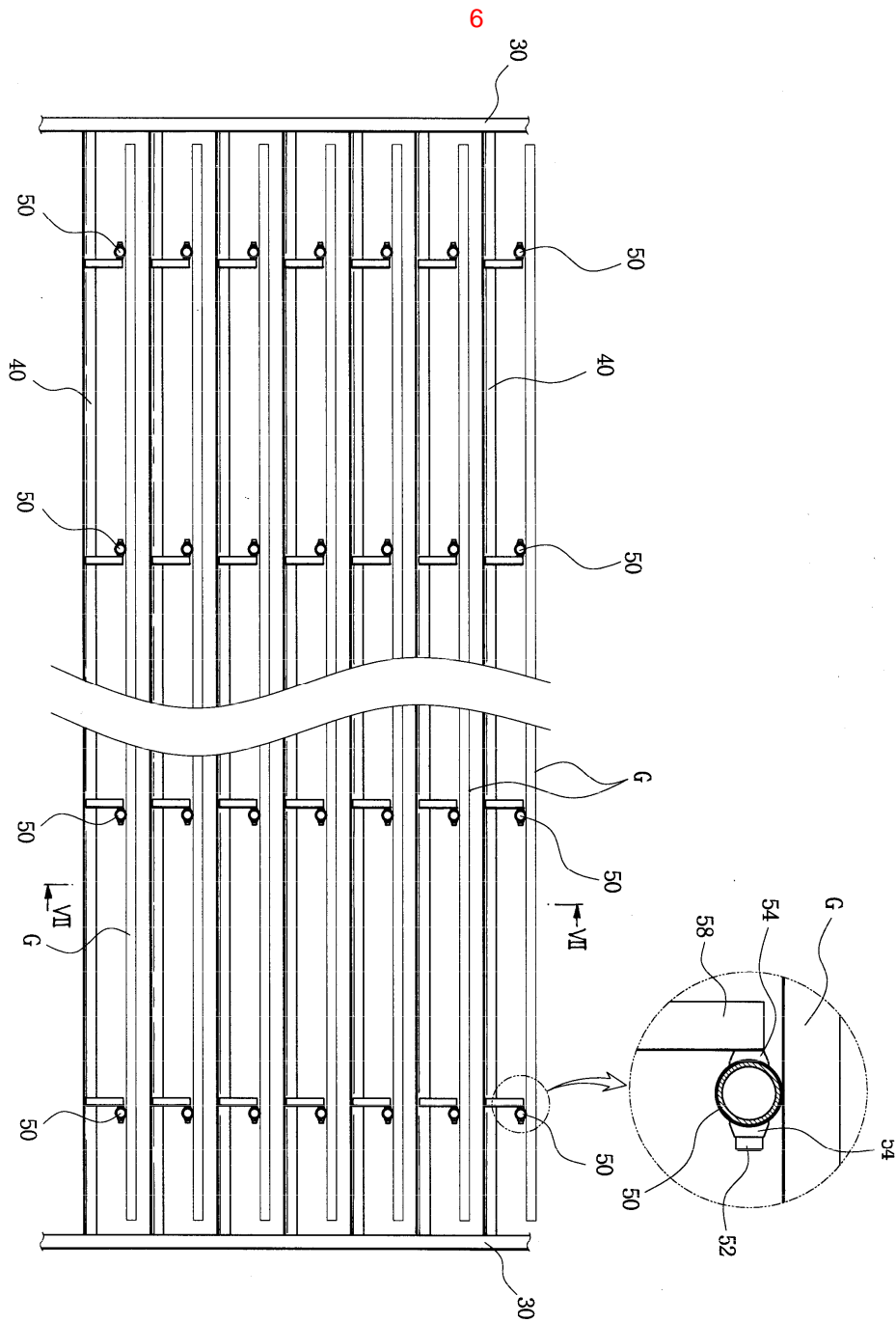

7

