



US 20120076649A1

(19) **United States**

(12) **Patent Application Publication**  
**YE**

(10) **Pub. No.: US 2012/0076649 A1**

(43) **Pub. Date: Mar. 29, 2012**

(54) **FAN HOLDER**

(30) **Foreign Application Priority Data**

(75) Inventor: **ZHEN-XING YE**, Shenzhen City (CN)

Sep. 23, 2010 (CN) ..... 201010289255.6

**Publication Classification**

(73) Assignees: **HON HAI PRECISION INDUSTRY CO., LTD.**, Tu-Cheng (TW); **HONG FU JIN PRECISION INDUSTRY (SHENZHEN) CO., LTD.**, Shenzhen City (CN)

(51) **Int. Cl.**  
**F04D 29/60** (2006.01)

(52) **U.S. Cl.** ..... **415/213.1**

(57) **ABSTRACT**

A fan holder includes a fixing member and a movable member mounted to the fixing member. The fixing member includes a first plate and two sidewalls perpendicularly extending from opposite sides of the first plate, respectively. The movable member includes a second plate opposite to the first plate and a number of slide portions perpendicularly extending from the second plate and slidably coupled to the sidewalls of the fixing member.

(21) Appl. No.: **12/899,733**

(22) Filed: **Oct. 7, 2010**

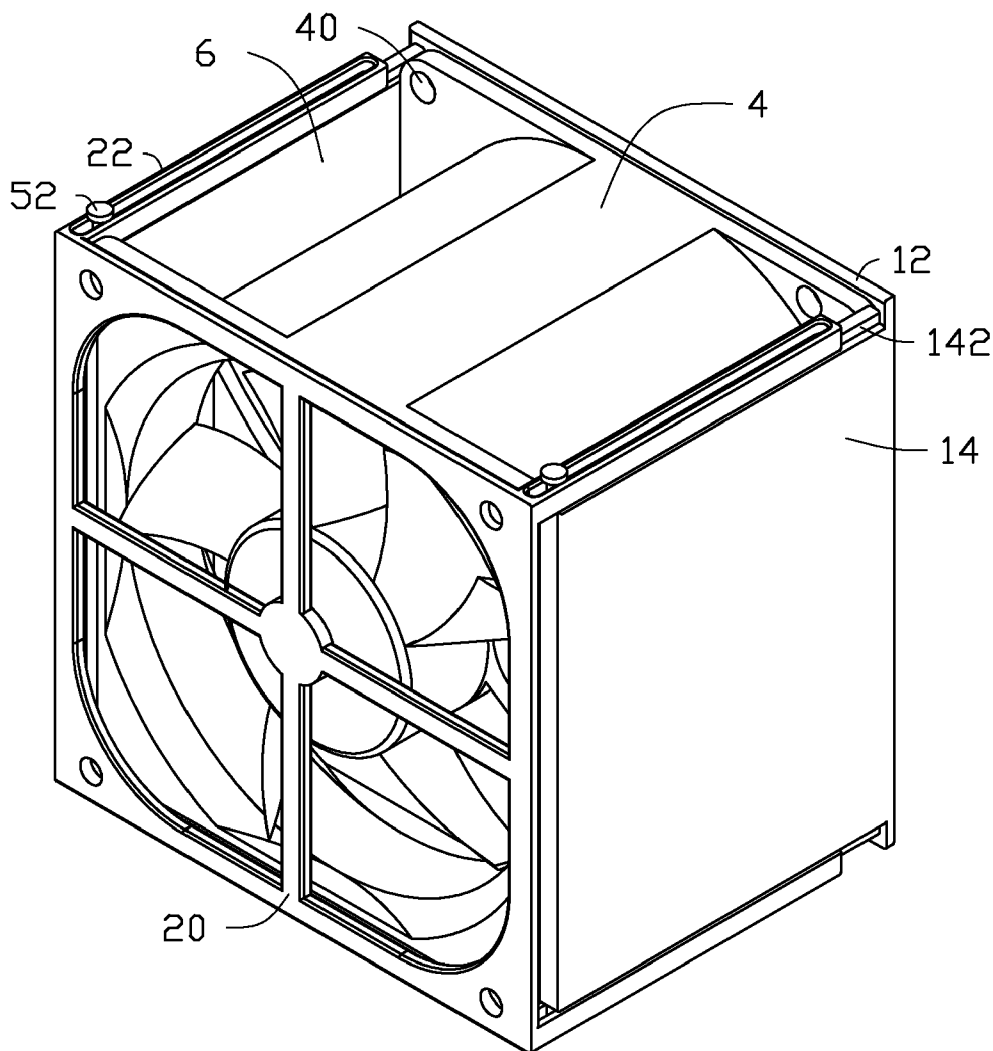

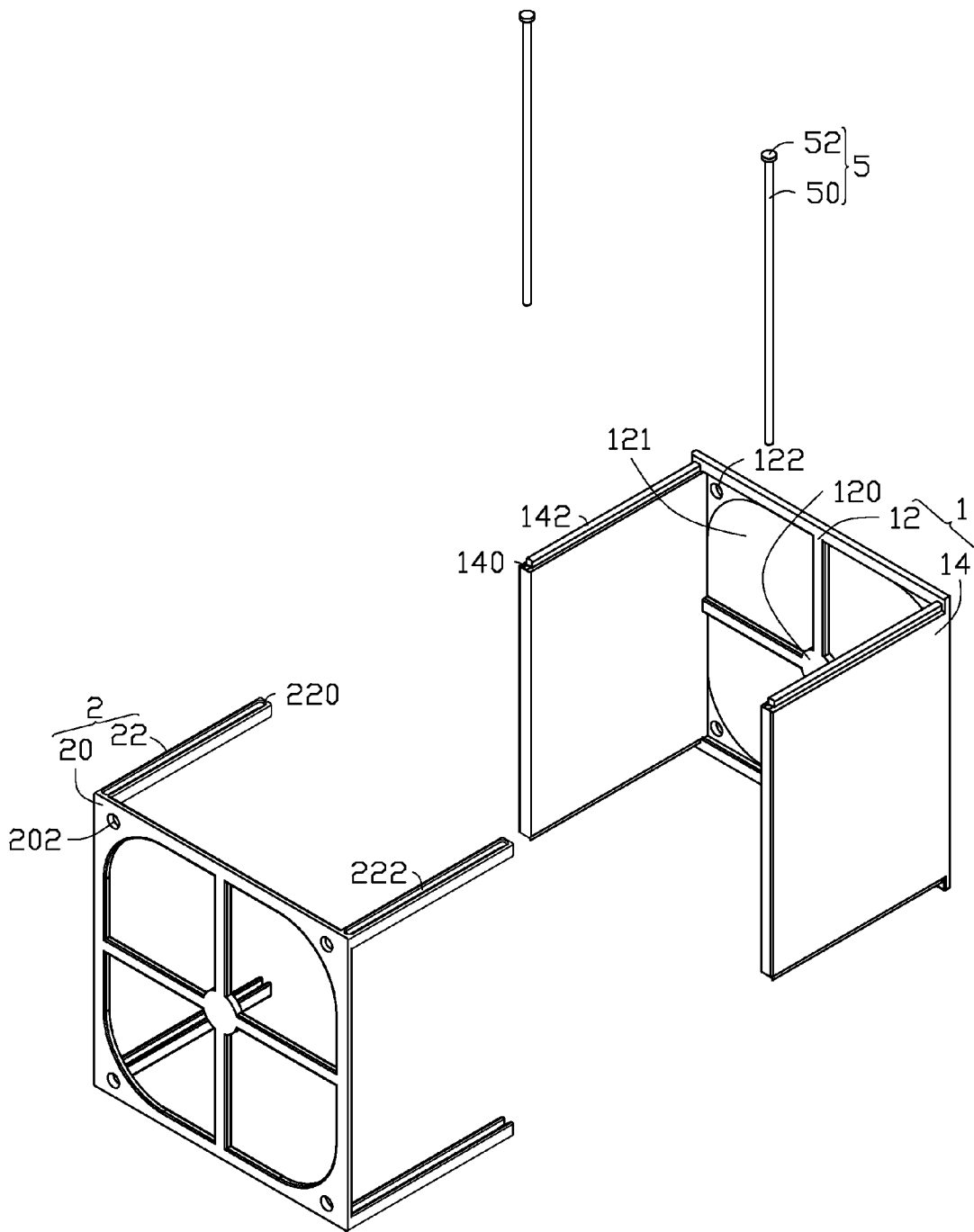

FIG. 1

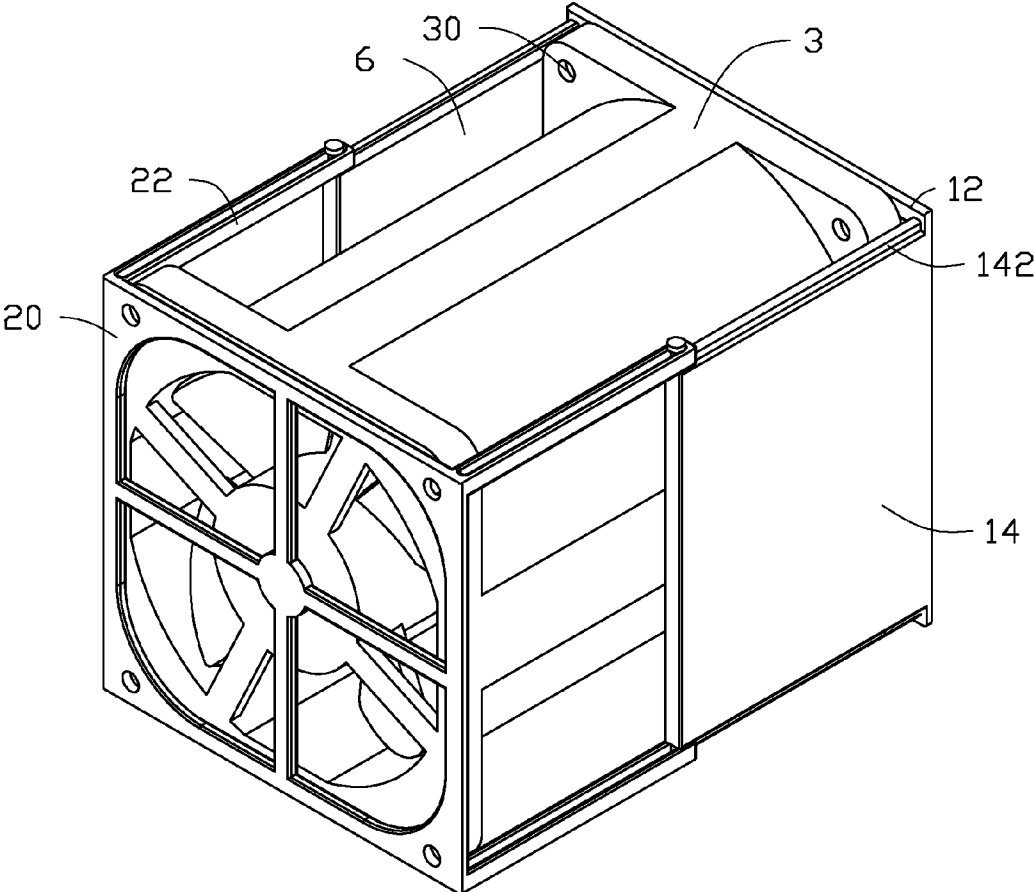

FIG. 2

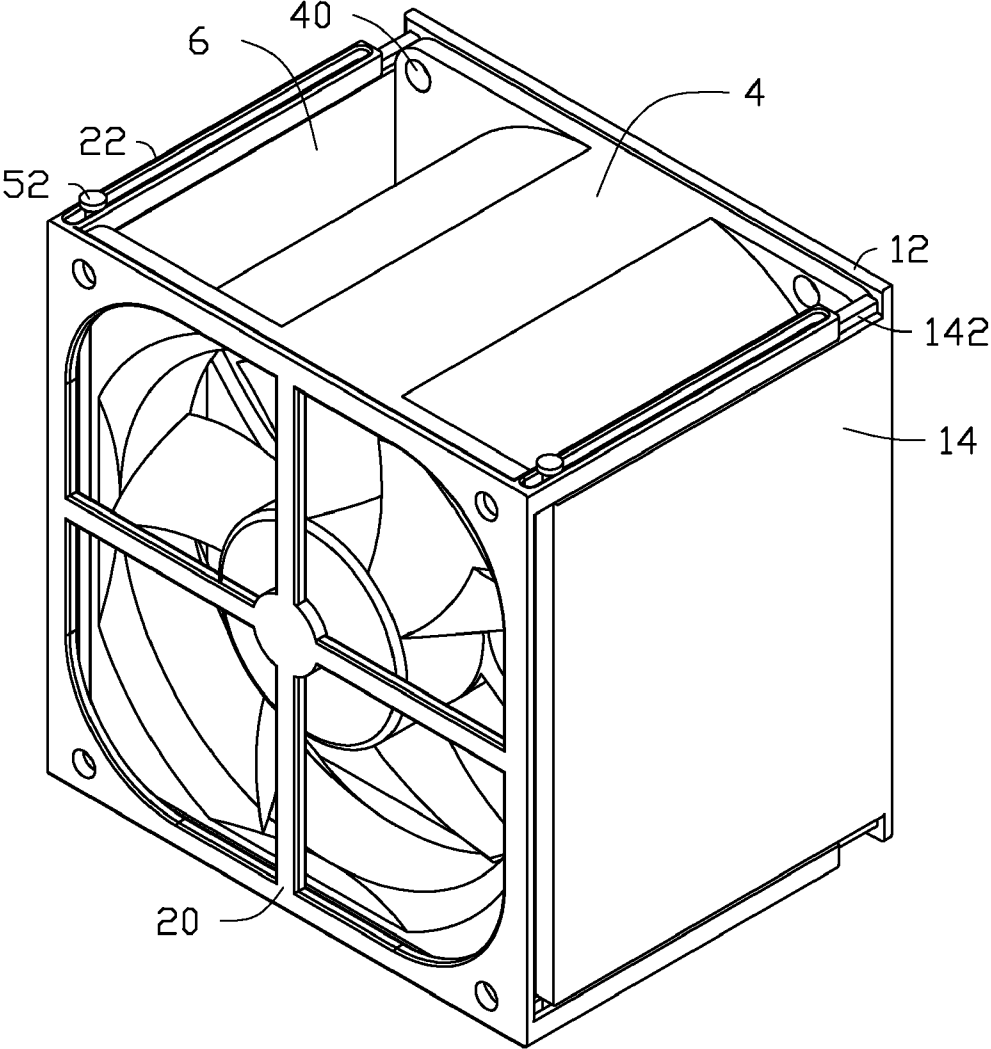

FIG. 3

## FAN HOLDER

### BACKGROUND

[0001] 1. Technical Field

[0002] The present disclosure relates to a fan holder.

[0003] 2. Description of Related Art

[0004] In computer systems, fans are generally fixed to fan fixing apparatuses. However, since there are different kinds of fans, as a result, it is costly to supply different kinds of fan fixing apparatuses to fix the corresponding fans.

### BRIEF DESCRIPTION OF THE DRAWINGS

[0005] Many aspects of the present embodiments can be better understood with reference to the following drawings. The components in the drawings are not necessarily drawn to scale, the emphasis instead being placed upon clearly illustrating the principles of the present embodiments. Moreover, in the drawings, all the views are schematic, and like reference numerals designate corresponding parts throughout the several views.

[0006] FIG. 1 is an exploded, isometric view of an exemplary embodiment of a fan holder.

[0007] FIG. 2 is an assembled, isometric view of the fan holder of FIG. 1, together with a first fan.

[0008] FIG. 3 is an assembled, isometric view of the fan holder of FIG. 1, together with a second fan.

### DETAILED DESCRIPTION

[0009] The disclosure, including the accompanying drawings, is illustrated by way of example and not by way of limitation. It should be noted that references to “an” or “one” embodiment in this disclosure are not necessarily to the same embodiment, and such references mean at least one.

[0010] Referring to FIG. 1, an exemplary embodiment of a fan holder includes a fixing member 1, a movable member 2 and two thread-less bolts 5.

[0011] The fixing member 1 includes a square-shaped first plate 12 and two sidewalls 14 perpendicularly extending from opposite sides of the first plate 12. The first plate 12 defines an opening 121 in a center of the first plate 12. A cross-shaped bracket 120 is arranged in the opening 121, with four distal ends of the bracket 120 connected to sides of the first plate 12 bounding the opening 121. A through hole 122 is defined in each of four corners of the first plate 12. Two guide portions 142 which are perpendicular to the first plate 12 extend from the top and the bottom of each sidewall 14, respectively. A through hole 140 is defined in a side of each sidewall 14 from the top to the bottom and away from the first plate 12.

[0012] The movable member 2 includes a second plate 20 substantially the same as the first plate 12, and four post-shaped slide portions 22 perpendicularly extending from four corners of the second plate 20 toward the same direction, respectively. An internally threaded through hole 202 is defined in each corner of the second plate 20. Each slide portion 22 defines an elongated slot 222 along the extension direction of the slide portion 22, with a blocking piece 220 formed at a distal end of the slide portion 22. The slide portions 22 are generally configured to receive the respective guide portions 142.

[0013] Each of the bolts 5 includes a smooth post 50 and a head 52. The diameter of the head 52 is larger than the diameter of the post 50 and the width of the slot 222.

[0014] Referring to FIG. 2, in assembly, the slide portions 22 of the movable member 2 slidably respectively engage with the corresponding guide portions 142 of the fixing member 1, with the slots 222 of the slide portions 22 respectively accommodating the corresponding guide portions 142 of the fixing member 1. The posts 50 of the bolts 5 are extended through two corresponding slots 222 of the movable member 2 and the corresponding through holes 140 of the fixing member 1, until the distal ends of the posts 50 contact in the other two corresponding slots 222 of the movable member 2. The bolts 50 are not otherwise engaged and are meant to ride in the slots 222 to block unwanted disengagement of the movable member 2 from the fixing member 1 and can be easily manually removed and reinserted when installing or removing fans. The heads 52 of the bolts 5 are blocked by the corresponding slide portions 22. Thereby, the movable member 2 is slidably installed to the fixing member 1. The movable member 2 and the fixing member 1 bound a receiving space 6.

[0015] In use, to mount a first fan 3 which has a large size, the movable member 2 is slid away from the fixing member 1, with the second plate 22 moving away from the first plate 12 and the posts 50 of the bolts 5 located adjacent to the blocking pieces 220 of the slide portions 22. Therefore, the receiving space 6 is expanded enough to receive the first fan 3. A plurality of screws (not shown) extends through the through holes 122 of the first plate 12, and through the through holes 202 of the second plate 20 respectively and are screwed into corresponding threaded fixing holes 30 of the first fan 3, thereby mounting the first fan 3 to the fan holder. In other embodiments, either the through holes 122 or the through holes 202 are internally threaded and longer screws are used that extend through the other holes to engage in the threaded through holes thereby reducing the number of screws needed.

[0016] Referring to FIG. 3, to alternatively mount a second fan 4 which has a small size, the slide portions 22 of the movable member 2 slide along the guide portions 142 of the fixing member 1, with the second plate 22 moving toward the first plate 12. The receiving space 6 dwindles to sandwich the second fan 4 between the first plate 12 and the second plate 20. And the plurality of screws (not shown) is applied in the same way as the previous embodiment thereby mounting the second fan 4 to the fan holder.

[0017] It is believed that the present embodiments and their advantages will be understood from the foregoing description, and they will be apparent that various changes may be made thereto without departing from the spirit and scope of the description or sacrificing all of their material advantages, the examples hereinbefore described merely being exemplary embodiment.

What is claimed is:

1. A fan holder for mounting a fan, comprising:

a fixing member comprising a first plate and two sidewalls perpendicularly extending from opposite sides of the first plate; and

a movable member comprising a second plate opposite to the first plate and a plurality of slide portions perpendicularly extending from the second plate and slidably coupled to the sidewalls of the fixing member, thereby a distance between the first and second plates is adjustable to fit the fan.

2. The fan holder of claim 1, wherein two guide portions extend from the top and the bottom of each sidewall of the fixing member, respectively; the number of the plurality of slide portions is four, an elongated slot is defined in each slide

portion along the extension direction of the slide portion to slidably engage with a corresponding guide portions.

3. The fan holder of claim 2, further comprising at least one bolt, wherein at least one of the sidewalls of the fixing member defines a through hole from the top to the bottom of the at least sidewall away from the first plate, each of the at least one bolt extends through the slot of one slide portion of the movable member, the through hole of the at least one sidewall of the fixing member, until a distal end of the bolt contacts in the slot of another slide portion engaged with the sidewall.

4. The fan holder of claim 2, further comprising two bolts, wherein the two sidewalls of the fixing member define two through holes from the tops to the bottoms of the sidewalls

away from the first plate, wherein the bolts extend through the slots of two corresponding slide portions of the movable member, the through holes of the sidewalls of the fixing member, until distal ends of the bolts contact in the other two corresponding slots of the movable member.

5. The fan holder of claim 1, wherein each of the first plate and the second plate defines an opening in a center, a cross-shaped bracket is arranged in the opening, with distal ends of the bracket connected to sides bounding the opening.

6. The fan holder of claim 1, wherein the first plate and the second plate are square-shaped, and define a through hole in each corner corresponding to a fixing hole of the fan.

\* \* \* \* \*