



US00D610052S

(12) **United States Design Patent**
Watanabe

(10) **Patent No.:** **US D610,052 S**

(45) **Date of Patent:** **** Feb. 16, 2010**

(54) **GRILL FOR AUTOMOBILE**

(75) Inventor: **Takayuki Watanabe**, Wako (JP)

(73) Assignee: **Honda Motor Co., Ltd.**, Tokyo (JP)

(**) Term: **14 Years**

(21) Appl. No.: **29/338,243**

(22) Filed: **Jun. 8, 2009**

(30) **Foreign Application Priority Data**

Dec. 12, 2008 (JP) 2008-031605

(51) **LOC (9) Cl.** **12-16**

(52) **U.S. Cl.** **D12/163**

(58) **Field of Classification Search** D12/163,
D12/196, 171, 169, 216, 90-92, 86; 180/68.1,
180/68.6; 296/193.11

See application file for complete search history.

(56) **References Cited**

U.S. PATENT DOCUMENTS

D475,662 S * 6/2003 Koizumi et al. D12/163

D557,641 S * 12/2007 Davidson D12/163

D573,924 S * 7/2008 Tachibana D12/163
D575,688 S * 8/2008 Miyata et al. D12/163
D584,198 S * 1/2009 Tamura D12/163
D592,564 S * 5/2009 Kusamoto et al. D12/163

* cited by examiner

Primary Examiner—Melody N Brown

(74) *Attorney, Agent, or Firm*—Westerman, Hattori, Daniels & Adrian, LLP

(57) **CLAIM**

The ornamental design for a grill for automobile, as shown and described.

DESCRIPTION

FIG. 1 is a perspective view from the front side of a grill for automobile.

FIG. 2 is a front elevation view thereof.

FIG. 3 is a top plan view thereof; and,

FIG. 4 is a right side elevation view thereof.

The portion of the grill shown in broken lines is for the purpose of showing background structure only and forms no part of the claimed design.

1 Claim, 4 Drawing Sheets

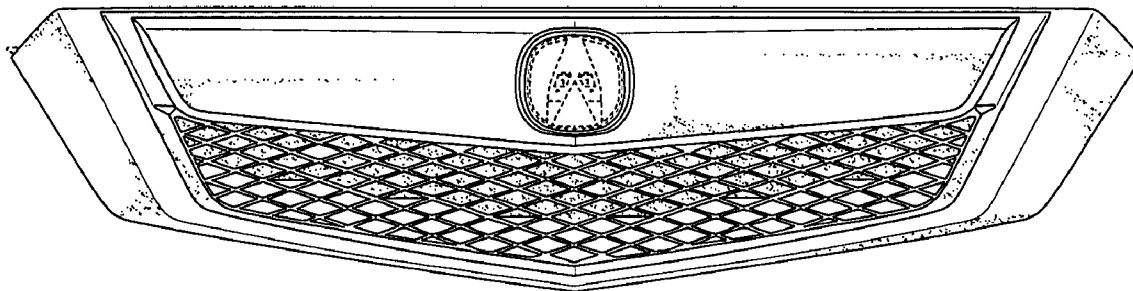

FIG. 1

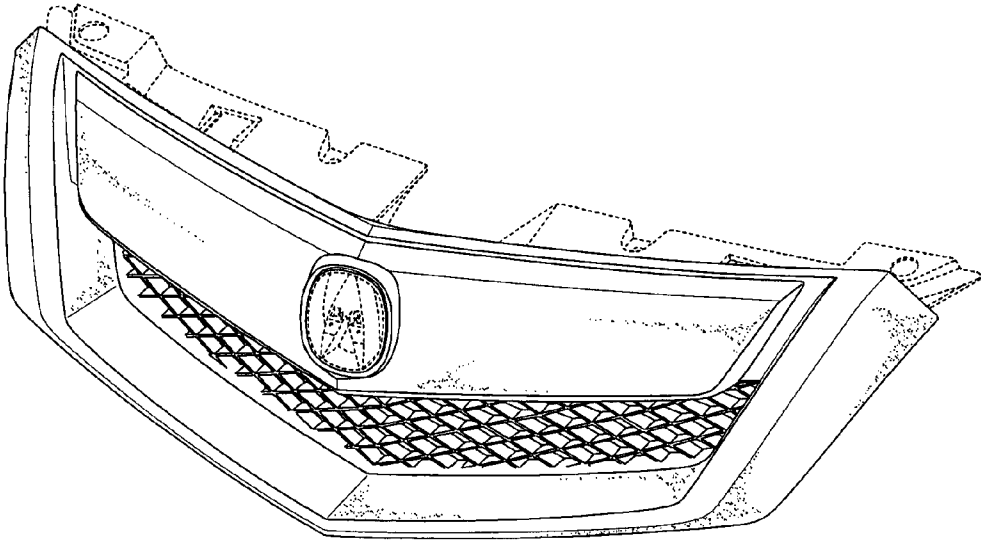

FIG. 2

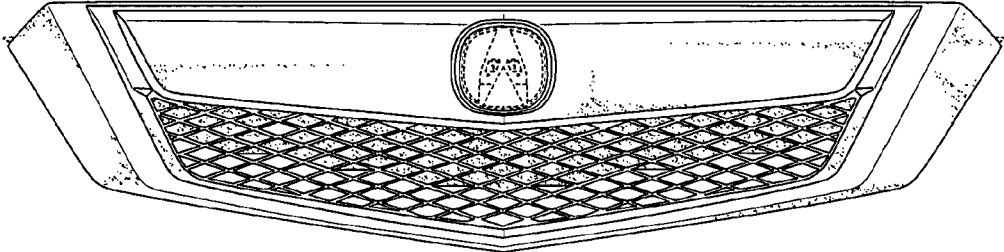

FIG. 3

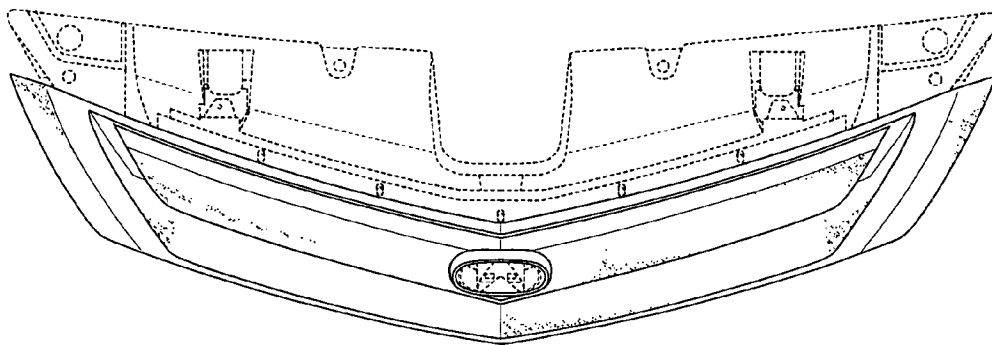

FIG. 4

