



US00D985116S

(12) **United States Design Patent**
Davis et al.

(10) **Patent No.:** **US D985,116 S**
(45) **Date of Patent:** **** May 2, 2023**

- (54) **HANDHELD DRUG DELIVERY DEVICE**
- (71) Applicant: **AMGEN INC.**, Thousand Oaks, CA (US)
- (72) Inventors: **Austin Davis**, Thousand Oaks, CA (US); **Lars Eilertsen**, Søborg (DK); **David Lavmand Muller**, Thousand Oaks, CA (US); **Rasmus Øhlenschläger**, Copenhagen V (DK); **Gregory Thomas Nowak**, Somerville, MA (US); **Kasper Poder**, Tikøb (DK); **Dylan Bourelle**, Woodland Hills, CA (US)
- (73) Assignee: **AMGEN INC.**, Thousand Oaks, CA (US)
- (**) Term: **15 Years**
- (21) Appl. No.: **29/773,601**
- (22) Filed: **Mar. 10, 2021**
- (51) **LOC (14) Cl.** **24-02**
- (52) **U.S. Cl.**
USPC **D24/113**
- (58) **Field of Classification Search**
USPC D24/112, 113, 114, 133, 186, 127-131;
D19/115-123, 177, 193
CPC A61M 5/3156; A61M 5/31591; A61M 5/3155; A61M 5/3157; A61M 5/24; A61M 5/31501; A61M 5/31551; A61M 5/31585
See application file for complete search history.

D443,641	S	6/2001	Mader
6,447,480	B1	9/2002	Brunel
6,454,746	B1	9/2002	Bydlon et al.
6,575,939	B1	6/2003	Brunel
6,585,702	B1	7/2003	Brunel
D497,806	S	11/2004	Nichols et al.
D509,296	S	9/2005	Minshull et al.
D545,895	S	7/2007	Okutani
7,247,153	B2	7/2007	Guala
7,370,759	B2	5/2008	Hommann
7,397,730	B2	7/2008	Skyggebjerg et al.
7,597,685	B2	10/2009	Olson
D605,006	S	12/2009	Shiao
D612,486	S	3/2010	Van der Stappen
D616,089	S	5/2010	Van der Stappen
D619,244	S	7/2010	Van der Stappen
D620,106	S	7/2010	Van der Stappen
D621,929	S	8/2010	Van der Stappen
D622,374	S	8/2010	Julian et al.
7,771,397	B1	8/2010	Olson
D623,738	S	9/2010	Van der Stappen
7,794,432	B2	9/2010	Young et al.
7,806,861	B2	10/2010	Witowski
D626,994	S	11/2010	Gerules
D627,061	S	11/2010	Van der Stappen
D628,690	S	12/2010	Galbraith
D629,509	S	12/2010	Julian et al.
D640,786	S	6/2011	Sato et al.
7,988,675	B2	8/2011	Gillespie, III et al.
8,062,255	B2	11/2011	Brunnberg et al.
D660,958	S	5/2012	McLoughlin et al.
8,298,194	B2	10/2012	Moeller
D671,638	S	11/2012	Young et al.
8,313,470	B2	11/2012	Abry
8,357,125	B2	1/2013	Grunhut et al.
8,361,025	B2	1/2013	Lawlis et al.
8,372,035	B2	2/2013	Matusch
D678,514	S	3/2013	Foley et al.
D683,016	S	5/2013	Mirza et al.
8,529,518	B2	9/2013	Larsen et al.
8,568,359	B2	10/2013	Carrel et al.
8,568,364	B2	10/2013	Plumptre
D692,998	S	11/2013	Broberg et al.
D696,397	S	12/2013	Guarraia et al.
D696,770	S	12/2013	Schneider et al.
D696,772	S	12/2013	Schneider et al.
D696,773	S	12/2013	Schneider et al.
D696,774	S	12/2013	Guarraia et al.
D696,775	S	12/2013	Guarraia et al.
8,608,709	B2	12/2013	Moeller et al.
D697,205	S	1/2014	Schneider et al.
8,647,299	B2	2/2014	Stamp
8,696,618	B2	4/2014	Kramer et al.

(56) **References Cited**
U.S. PATENT DOCUMENTS

758,567	A	4/1904	Siebelist
3,316,909	A	5/1967	Cowley
D321,472	S	11/1991	Evans et al.
5,098,400	A	3/1992	Crouse et al.
5,562,637	A	10/1996	Uitterberg
5,569,192	A	10/1996	Van der Wal
5,964,731	A	10/1999	Kovelman

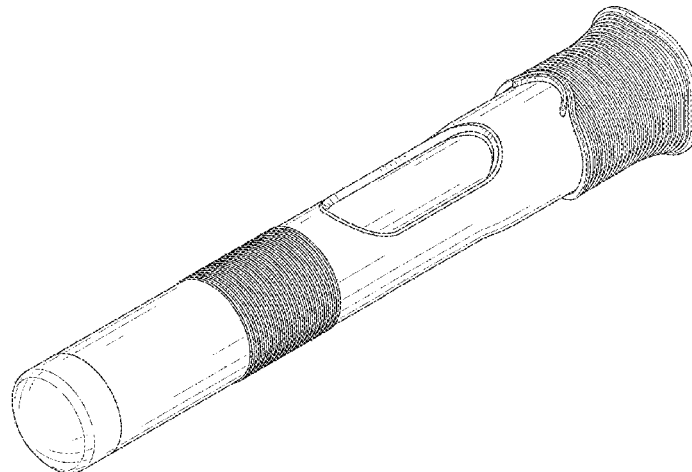

US D985,116 S

8,740,871 B2	6/2014	Lawlis et al.	RE46,789 E	4/2018	Olson	
D708,317 S	7/2014	Schneider et al.	D815,732 S	4/2018	Mills et al.	
8,814,828 B2	8/2014	Llewellyn-Hyde et al.	D816,212 S	4/2018	Daniel et al.	
8,817,258 B2	8/2014	Whalley et al.	D819,198 S	5/2018	Boyaval et al.	
D714,932 S	10/2014	Hall et al.	D819,200 S	5/2018	Stonecipher et al.	
D715,422 S	10/2014	Hall et al.	D819,804 S	6/2018	Knight et al.	
D717,428 S	11/2014	Sendatzki et al.	9,987,436 B2	6/2018	Giambattista et al.	
8,882,722 B2	11/2014	Bode et al.	D822,198 S	7/2018	Stonecipher et al.	
D721,802 S	1/2015	Ohashi	D822,199 S	7/2018	Clawson et al.	
D722,158 S	2/2015	Magome et al.	D823,459 S	7/2018	Bendek et al.	
D722,256 S	2/2015	Kita	D827,127 S	8/2018	Donnelly	
8,945,065 B2	2/2015	Torris et al.	D827,128 S	8/2018	Boyaval et al.	
8,945,067 B2	2/2015	McLoughlin et al.	D830,539 S	10/2018	Boyaval et al.	
8,992,484 B2	3/2015	Radmer et al.	D831,822 S	10/2018	Guillermo et al.	
D726,902 S	4/2015	McLoughlin et al.	10,159,795 B2	12/2018	Cave	
D728,782 S	5/2015	Dubuc et al.	10,265,476 B2	4/2019	Laiosa et al.	
9,022,982 B2	5/2015	Karlsson et al.	D851,754 S	6/2019	Boyaval et al.	
9,033,932 B2	5/2015	Holmqvist	10,335,553 B2	7/2019	Bendek	
D732,161 S	6/2015	Ohashi	D857,192 S	8/2019	Burkett et al.	
D732,661 S	6/2015	Dubuc et al.	D861,859 S	10/2019	Rapp et al.	
D733,869 S	7/2015	Ratjen	D864,378 S	10/2019	Tafazoli et al.	
9,072,833 B2	7/2015	Jennings et al.	D866,751 S	11/2019	Rogge et al.	
9,078,973 B2	7/2015	Harms et al.	D866,752 S	11/2019	Rogge et al.	
D735,848 S	8/2015	Dubuc et al.	D866,757 S *	11/2019	Diluzio	D24/133
9,114,212 B2	8/2015	Enggaard et al.	D867,588 S	11/2019	Rogge et al.	
D737,639 S	9/2015	Masalin et al.	D868,245 S	11/2019	Holmqvist et al.	
D739,011 S	9/2015	Morrison et al.	D868,961 S	12/2019	Stewart et al.	
D739,932 S	9/2015	Ratjen et al.	D870,270 S	12/2019	Burkett et al.	
9,174,000 B2	11/2015	Bode	10,512,725 B1	12/2019	Bauss et al.	
9,233,212 B2	1/2016	Holmqvist	D878,560 S	3/2020	Boyaval et al.	
9,238,111 B2	1/2016	Marshall et al.	D878,563 S	3/2020	Clawson et al.	
9,242,050 B2	1/2016	Abry	D878,564 S	3/2020	Clawson et al.	
9,272,094 B2	3/2016	Boyd et al.	D878,566 S	3/2020	Jansen	
9,295,784 B2	3/2016	Eggert et al.	D882,071 S	4/2020	Stonecipher et al.	
9,302,053 B2	4/2016	Holmqvist	RE48,006 E	5/2020	Fourt et al.	
D755,956 S	5/2016	McLoughlin et al.	D883,475 S	5/2020	Boyaval et al.	
D757,255 S	5/2016	Wohlfahrt et al.	D884,161 S *	5/2020	Stewart	D24/112
9,333,305 B2	5/2016	McLoughlin et al.	D886,281 S	6/2020	Boyaval et al.	
9,339,610 B2	5/2016	Julian et al.	D886,282 S	6/2020	Stonecipher et al.	
D758,566 S	6/2016	Chen	D892,311 S	8/2020	Nicholas et al.	
D758,567 S	6/2016	Wohlfahrt et al.	D892,312 S	8/2020	Nicholas et al.	
D758,568 S	6/2016	Wohlfahrt et al.	D893,710 S	8/2020	Neby	
D758,569 S	6/2016	Wohlfahrt et al.	10,780,256 B2	9/2020	Cordoba et al.	
D758,570 S	6/2016	Wohlfahrt et al.	D898,189 S	10/2020	Boyaval et al.	
D758,571 S	6/2016	Geert-Jensen et al.	D898,900 S	10/2020	Atterbury et al.	
D759,813 S	6/2016	Newman et al.	D917,064 S	4/2021	Ribeiro et al.	
D759,814 S	6/2016	Newman et al.	D922,566 S	6/2021	Ono	
D765,239 S	8/2016	Hauck et al.	D922,567 S	6/2021	Boyaval et al.	
D765,240 S	8/2016	Hauck et al.	D931,443 S	9/2021	Bainton et al.	
9,421,336 B2	8/2016	Ekman et al.	D956,212 S *	6/2022	Petersen	D24/113
D766,425 S	9/2016	Hauck et al.	D958,329 S *	7/2022	Bourelle	D24/113
D767,119 S	9/2016	Hauck et al.	D962,423 S *	8/2022	Melander	D24/113
D770,610 S	11/2016	Saussaye et al.	2004/0068283 A1	4/2004	Fukuzawa et al.	
D773,648 S	12/2016	Wohlfahrt et al.	2005/0148933 A1	7/2005	Raven et al.	
D773,650 S	12/2016	Fourt et al.	2006/0100655 A1	5/2006	Leong et al.	
D774,639 S	12/2016	Saussaye et al.	2008/0269682 A1	10/2008	Kavazov et al.	
D774,641 S	12/2016	Miggels et al.	2008/0269692 A1	10/2008	James et al.	
D775,279 S	12/2016	Shen	2009/0054849 A1	2/2009	Burnell et al.	
D780,909 S	3/2017	Burkett et al.	2009/0234297 A1	9/2009	Jennings	
D783,816 S	4/2017	Wohlfahrt et al.	2010/0152659 A1	6/2010	Streit et al.	
9,623,199 B2	4/2017	Richter et al.	2011/0098656 A1	4/2011	Burnell et al.	
9,656,027 B2	5/2017	Quinn	2012/0089098 A1	4/2012	Boyd et al.	
D788,909 S	6/2017	Ratjen	2012/0123347 A1	5/2012	Boyd et al.	
D789,519 S	6/2017	Ratjen et al.	2012/0123350 A1	5/2012	Giambattista et al.	
D790,686 S	6/2017	Cox et al.	2012/0197208 A1	8/2012	Bruggemann et al.	
D793,547 S	8/2017	Burkett et al.	2012/0232474 A1	9/2012	Nielsen et al.	
D794,178 S	8/2017	Daniel et al.	2013/0035645 A1	2/2013	Bicknell et al.	
D794,777 S	8/2017	Daniel et al.	2013/0060231 A1	3/2013	Adlon et al.	
D794,778 S	8/2017	Daniel et al.	2013/0150802 A1	6/2013	Cloughton	
D799,026 S	10/2017	Jones et al.	2013/0211330 A1	8/2013	Pedersen et al.	
D802,748 S	11/2017	Mills et al.	2013/0211340 A1	8/2013	Helmer	
D802,751 S	11/2017	Ratjen et al.	2013/0274671 A1	10/2013	Jennings et al.	
D809,137 S	1/2018	Ratjen	2013/0281933 A1	10/2013	Cowe et al.	
D810,280 S	2/2018	Tharp et al.	2013/0310746 A1	11/2013	Wozencroft	
D810,282 S	2/2018	Ratjen	2013/0331796 A1	12/2013	Wozencroft	
9,895,493 B2	2/2018	Burnell et al.	2014/0012205 A1	1/2014	Jugl et al.	
D812,746 S	3/2018	Umamura	2014/0094743 A1	4/2014	Bengtsson	
D813,379 S	3/2018	Mills et al.	2014/0101912 A1	4/2014	Abry	
D814,022 S *	3/2018	Boyaval	D24/113	2014/0207073 A1	7/2014	Shang et al.

US D985,116 S

Page 3

2014/0213985	A1	7/2014	Teucher et al.	
2014/0221916	A1	8/2014	Kramer et al.	
2014/0221936	A1	8/2014	Edhouse et al.	
2014/0228769	A1	8/2014	Karlsson et al.	
2014/0243750	A1	8/2014	Larsen et al.	
2014/0243753	A1	8/2014	Boström	
2014/0323976	A1	10/2014	Jugl et al.	
2014/0330216	A1	11/2014	Weaver et al.	
2014/0336588	A1	11/2014	McLoughlin et al.	
2014/0343503	A1	11/2014	Holmqvist	
2014/0343507	A1	11/2014	Karlsson et al.	
2014/0364812	A1	12/2014	Lumme et al.	
2014/0371684	A1	12/2014	Holmqvist	
2015/0051553	A1	2/2015	Björk et al.	
2015/0174325	A1	6/2015	Young et al.	
2015/0190577	A1	7/2015	Shaanan et al.	
2015/0202368	A1	7/2015	Carrel et al.	
2015/0290396	A1	10/2015	Nagar et al.	
2015/0335829	A1	11/2015	Giambattista et al.	
2015/0367081	A1	12/2015	Rosenthal	
2016/0082198	A1	3/2016	Holmqvist	
2016/0106929	A1	4/2016	Fournier et al.	
2016/0144132	A1	5/2016	Scanlon	
2016/0151586	A1	6/2016	Kemp	
2016/0193413	A1	7/2016	Gabrielsson	
2016/0199589	A1	7/2016	Plumptre	
2016/0220763	A1	8/2016	Teucher et al.	
2016/0250421	A1	9/2016	Fincham et al.	
2016/0263325	A1	9/2016	Huthmacher et al.	
2016/0303327	A1	10/2016	Moren	
2017/0128668	A1	5/2017	Miller et al.	
2017/0182242	A1	6/2017	Galitz et al.	
2018/0043101	A1	2/2018	Weaver et al.	
2018/0104413	A1	4/2018	McLoughlin et al.	
2019/0247589	A1	8/2019	Holmqvist et al.	
2019/0266921	A1	8/2019	Chang	
2019/0298924	A1	10/2019	Gibson et al.	
2019/0328485	A1	10/2019	Bauss et al.	
2020/0179612	A1	6/2020	Wei	
2020/0258425	A1	8/2020	Foley et al.	
2020/0289753	A1	9/2020	André et al.	
2021/0093789	A1	4/2021	Plambech et al.	
2021/0093796	A1*	4/2021	Finkelstein	A61M 5/3157
2021/0093797	A1	4/2021	Finkelstein et al.	
2021/0093799	A1	4/2021	Perot et al.	
2021/0121633	A1*	4/2021	Finkelstein	A61M 5/2422

FOREIGN PATENT DOCUMENTS

CA	3127415	A1	9/2020	
CN	302858428	S	6/2014	
CN	304223460	S	7/2017	
EM	008038723-0005	*	7/2020	
EP	0896827	A1	2/1999	
EP	1053037	A1	11/2000	
EP	1755706	A1	2/2007	
EP	2253348	A1	11/2010	
EP	2255842	A1	12/2010	
EP	2298390	A1	3/2011	
EP	2361648	A1	8/2011	
EP	2555820	A2	2/2013	
EP	2729203	A1	5/2014	
EP	2788048	A1	10/2014	
EP	2878321	A1	6/2015	
EP	2902063	A1	8/2015	
EP	3038682	A1	7/2016	
EP	3184138	A1	6/2017	
GB	9008041362-0012	*	7/2020	
GB	6133354		4/2021	
GB	6133358	*	4/2021	
IL	67773	A	2/1985	
JP	D1607619	*	6/2018	
JP	1634556	S	6/2019	
JP	2020-534959	A	12/2020	
JP	1691711	S	8/2021	
RU	100256	U1	12/2010	
RU	100299	U1	12/2010	
TW	D179360		11/2016	
TW	D179362		11/2016	

WO	99/39759	A1	8/1999	
WO	02/87670	A1	11/2002	
WO	2005/115508	A1	12/2005	
WO	2010/142812	A1	12/2010	
WO	2011/126439	A1	10/2011	
WO	2012/003516	A2	1/2012	
WO	2012/065965	A1	5/2012	
WO	2013/006119	A1	1/2013	
WO	2013/085454	A1	6/2013	
WO	2013/139894	A1	9/2013	
WO	2014/096957	A2	6/2014	
WO	2014/118105	A1	8/2014	
WO	2015/001819	A1	1/2015	
WO	2015/028488	A1	3/2015	
WO	2015/085068	A1	6/2015	
WO	2015/110533	A2	7/2015	
WO	2016/055334	A1	4/2016	
WO	2016/062807	A1	4/2016	
WO	2016/102299	A1	6/2016	
WO	2016/198387	A1	12/2016	
WO	2018/111796	A1	6/2018	
WO	2018/202458	A1	11/2018	
WO	2021/030066	A1	2/2021	

OTHER PUBLICATIONS

Aimovig, Amgen, [Postdate unknown], [Site seen Sep. 6, 2022], Seen at URL: <https://www.amgeninjectiondemos.com/Aimovig> (Year: 2022).*

Parental Drug Association, “Trends in the Self-injection Device Market & next Generation Platform Technologies,” [postdate 2018], [Site seen Sep. 6, 2022], Seen at URL: <https://pda-asiapacific.glueup.com/resources/protected/organization/1176/event/26285/93bd1ce6-33aa-48c1-b0b7-9833dd5155bc.pdf> (Year: 2022).*

Industrial Design DM/092744, Millennium Pharmaceuticals, Inc., Registration date Sep. 6, 2016.

Internet publication <https://www.youtube.com/watch?v=VbGb5lt9n80>, dated Sep. 30, 2014.

Office Action and Search Report for Taiwan application No. 1066305338, dated Mar. 26, 2018.

Office Action, Israel Design Office, Application No. 60912, dated Mar. 4, 2018.

McGowan, 30 Years in the Making—An Inside Perspective on the Emergence of Autoinjectors, ONdrugDelivery Magazine, Issue 101, pp. 20-23 (Oct. 2019).

“30 Years in the Making—An Inside Perspective on the Emergence of Autoinjectors”, available on ON drug Delivery Magazine, Issue 101 (Oct. 2019), pp. 20-23, by McGowan M, published Oct. 2, 2019 [online], [site visited Dec. 7, 2021], Internet URL: https://www.ondrugdelivery.com/wp-content/uploads/2019/09/101_2019_SHL_article.pdf (Year: 2019).

Auto Injectors and Inhaler Systems, Pharmaceutical Technology, [postdate: unknown], [Site seen May 3, 2022], Seen at URL: <https://www.pharmaceutical-technology.com/contractors/drug-delivery/shl-group/> (Year 2022).

BD Vystra Disposable Pen, BD.com, [Postdate: Jan. 9, 2019], [Site seen May 3, 2022], Seen at URL: <https://drugdeliverysystems.bd.com/products/self-injection-systems/vystra-disposable-pen> (Year: 2019).

International Application No. PCT/US22/19414, International Search Report and Written Opinion, dated Jul. 1, 2022.

International Application No. PCT/US22/19418, International Search Report and Written Opinion, dated Jul. 13, 2022.

Parental Drug Association, “Trends in the Self-injection Device Market & next Generation Platform Technologies,” [post date 2018], [Site seen Sep. 6, 2022], Seen at URL: <https://pda-asiapacific.glueup.com/resources/protected/organization/1176/event/26285/93bd1ce6-33aa-48c1-50b7-9833dd5155bc.pdf> (Year: 2022).

Roy et al., Autoinjector—A smart device for emergency cum personal therapy, Saudi Pharmaceutical Journal, 29(10):1205-1215 (2021).

U.S. Appl. No. 29/726,050, Ex Parte Quayle Action, dated Jan. 7, 2022.

U.S. Appl. No. 29/726,050, Notice of Allowance, dated Mar. 23, 2022.

U.S. Appl. No. 29/773,604, Requirement for Restriction/Election, dated Jun. 22, 2022.

U.S. Appl. No. 29/776,495, Requirement for Restriction/Election, dated Jun. 22, 2022.

U.S. Appl. No. 29/776,495, Notice of Allowance, dated Jan. 20, 2023.

U.S. Appl. No. 29/783,469, Requirement for Restriction/Election, dated Dec. 20, 2022.

* cited by examiner

Primary Examiner — Natasha Vujcic

Assistant Examiner — Gilbert B Ford

(74) *Attorney, Agent, or Firm* — Marshall, Gerstein & Borun LLP

(57) **CLAIM**

We claim, the ornamental design for a handheld drug delivery device, as shown and described.

DESCRIPTION

This patent or application file contains a least one drawing executed partly in color. Copies of this patent or patent application publication with drawing(s) partly in color will be provided by the Office upon request and payment of any necessary fee.

FIG. 1 is a perspective view showing a first embodiment for a handheld drug delivery device;

FIG. 2 is a front view of the handheld drug delivery device of FIG. 1;

FIG. 3 is a rear view of the handheld drug delivery device of FIG. 1;

FIG. 4 is a right-side view of the handheld drug delivery device of FIG. 1;

FIG. 5 is a left-side view of the handheld drug delivery device of FIG. 1;

FIG. 6 is a top view of the handheld drug delivery device of FIG. 1;

FIG. 7 is a bottom view of the handheld drug delivery device of FIG. 1;

FIG. 8 is a perspective view of the handheld drug delivery device of FIG. 1 with its cap removed;

FIG. 9 is a perspective view showing a second embodiment for a handheld drug delivery device;

FIG. 10 is a front view of the handheld drug delivery device of FIG. 9;

FIG. 11 is a rear view of the handheld drug delivery device of FIG. 9;

FIG. 12 is a right-side view of the handheld drug delivery device of FIG. 9;

FIG. 13 is a left-side view of the handheld drug delivery device of FIG. 9;

FIG. 14 is a top view of the handheld drug delivery device of FIG. 9;

FIG. 15 is a bottom view of the handheld drug delivery device of FIG. 9;

FIG. 16 is a perspective view of the handheld drug delivery device of FIG. 9 with its cap removed;

FIG. 17 is a perspective view showing a third embodiment for a handheld drug delivery device;

FIG. 18 is a front view of the handheld drug delivery device of FIG. 17;

FIG. 19 is a rear view of the handheld drug delivery device of FIG. 17;

FIG. 20 is a right-side view of the handheld drug delivery device of FIG. 17;

FIG. 21 is a left-side view of the handheld drug delivery device of FIG. 17;

FIG. 22 is a top view of the handheld drug delivery device of FIG. 17;

FIG. 23 is a bottom view of the handheld drug delivery device of FIG. 17; and,

FIG. 24 is a perspective view of the handheld drug delivery device of FIG. 17 with its cap removed.

The broken lines showing portions of the design are included for the purpose of illustrating portions of the design that form no part of the claimed design.

**1 Claim, 15 Drawing Sheets
(5 of 15 Drawing Sheet(s) Filed in Color)**

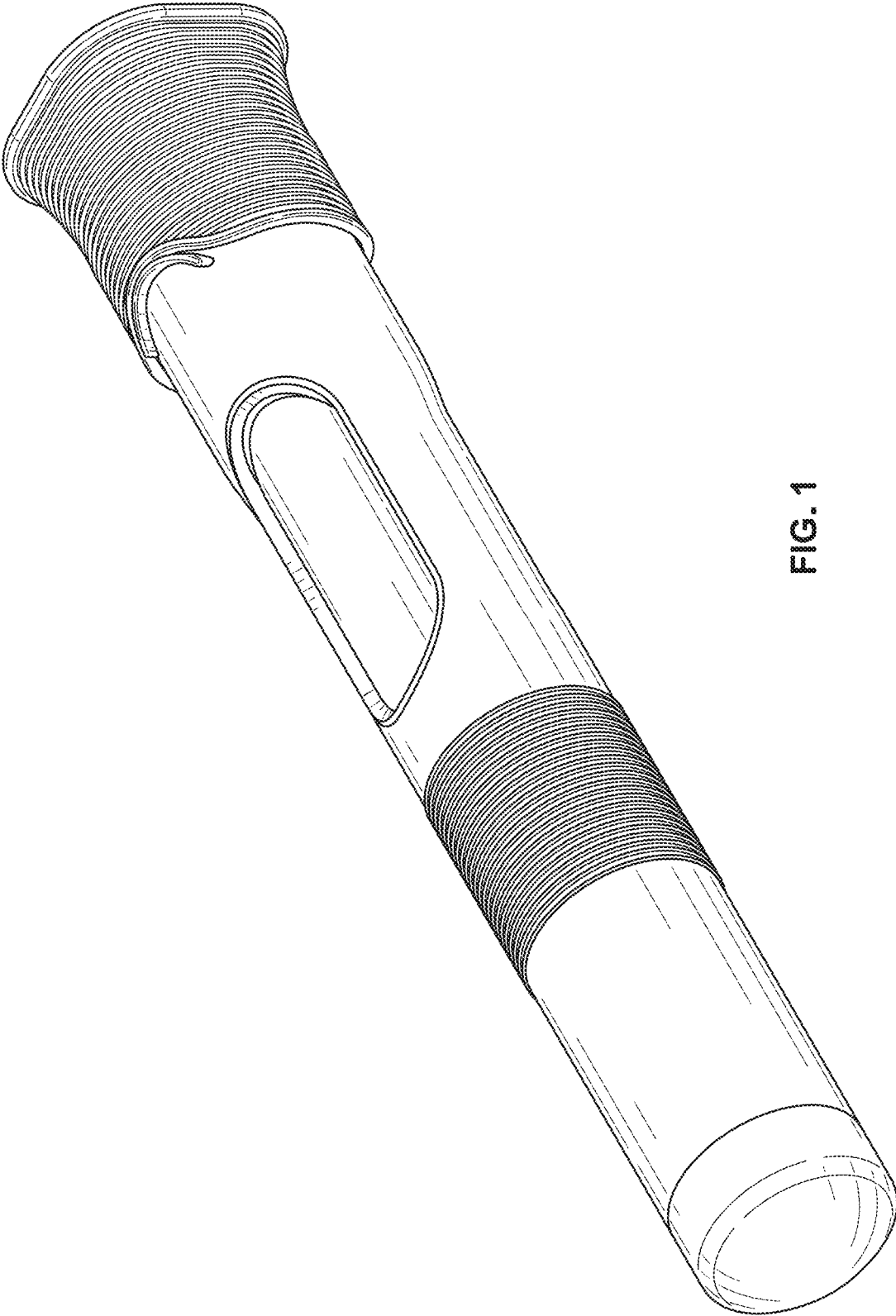

FIG. 1

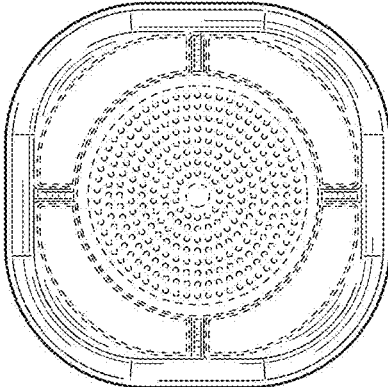

FIG. 2

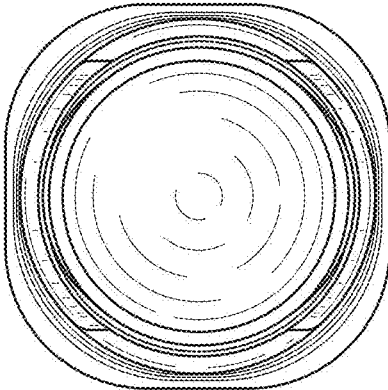

FIG. 3

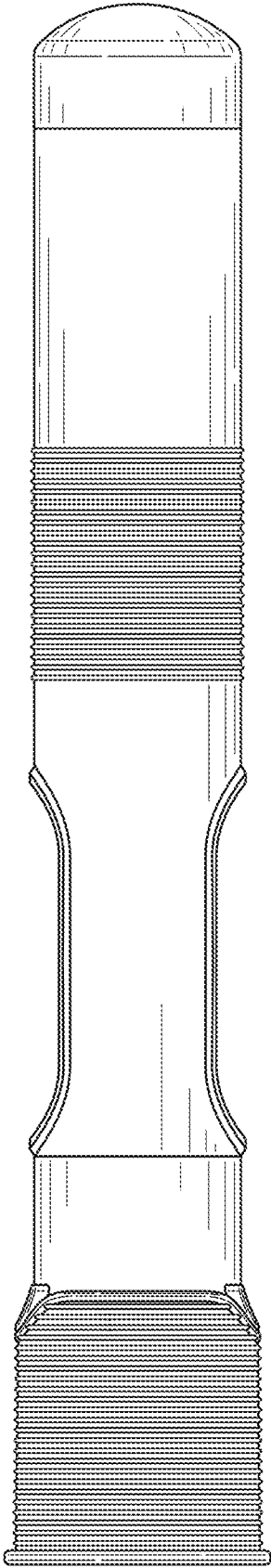

FIG. 4

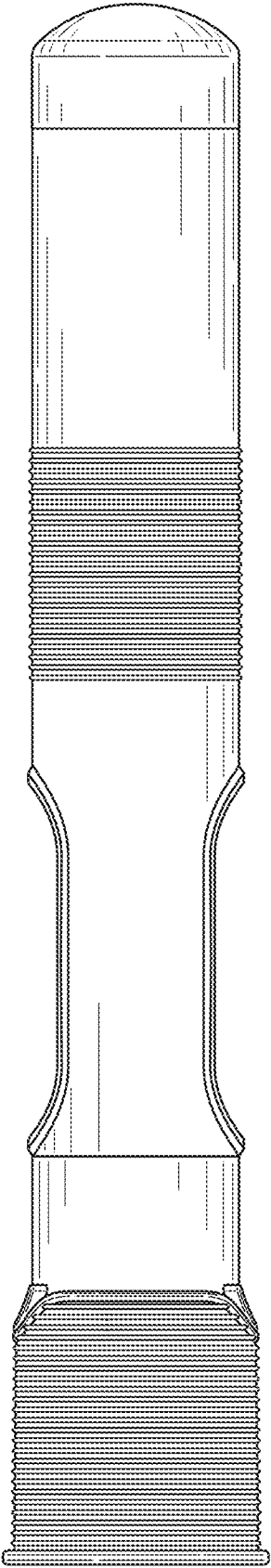

FIG. 5

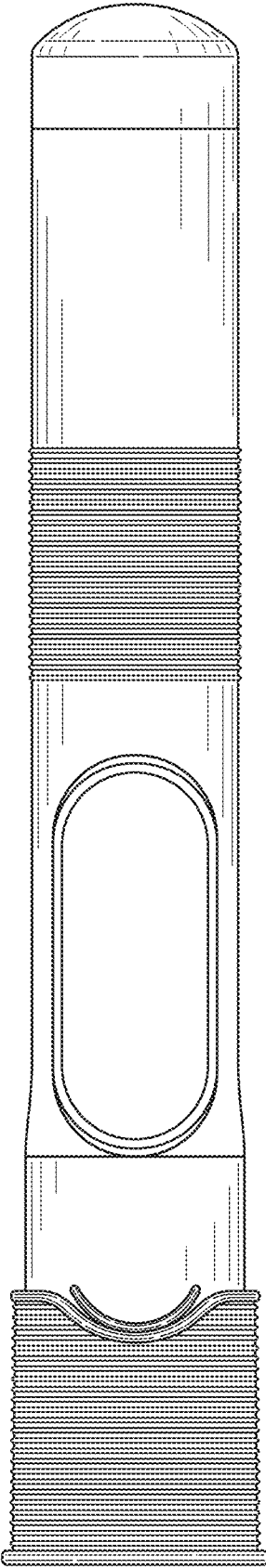

FIG. 6

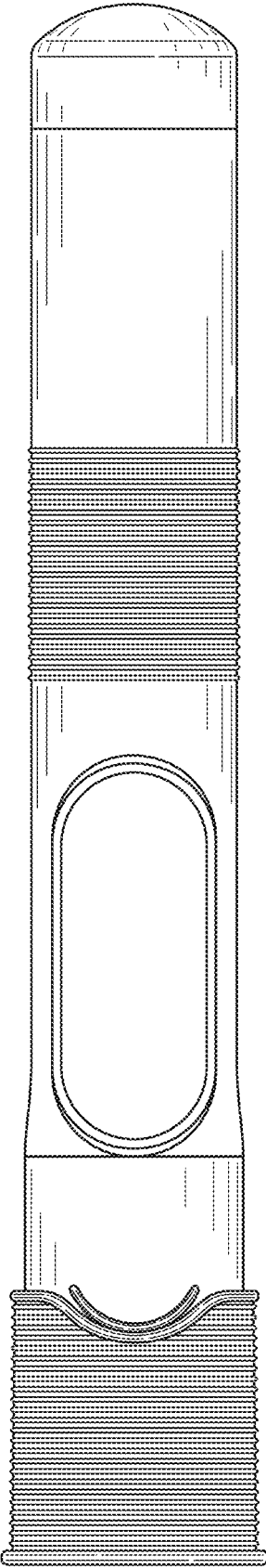

FIG. 7

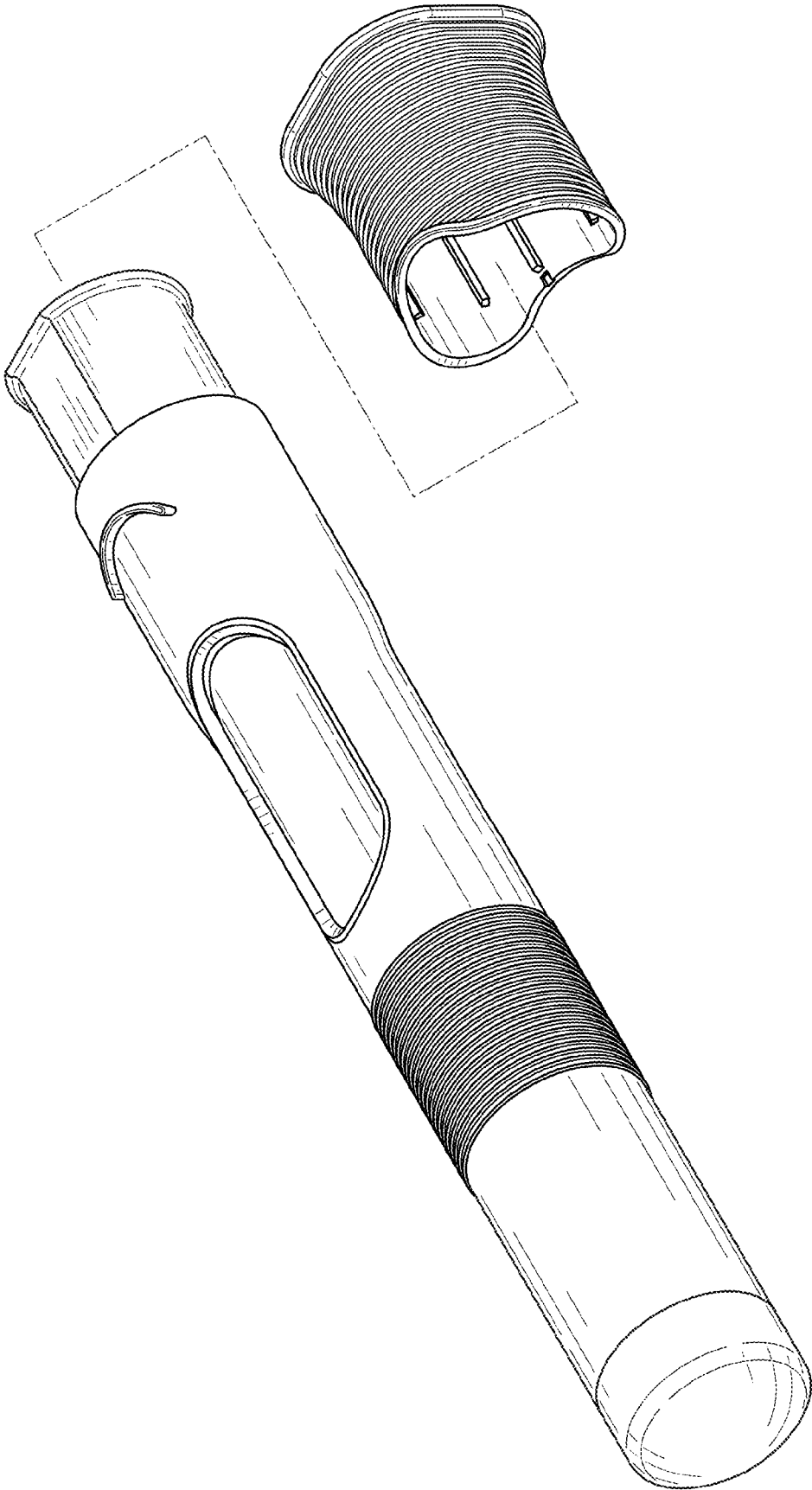

FIG. 8

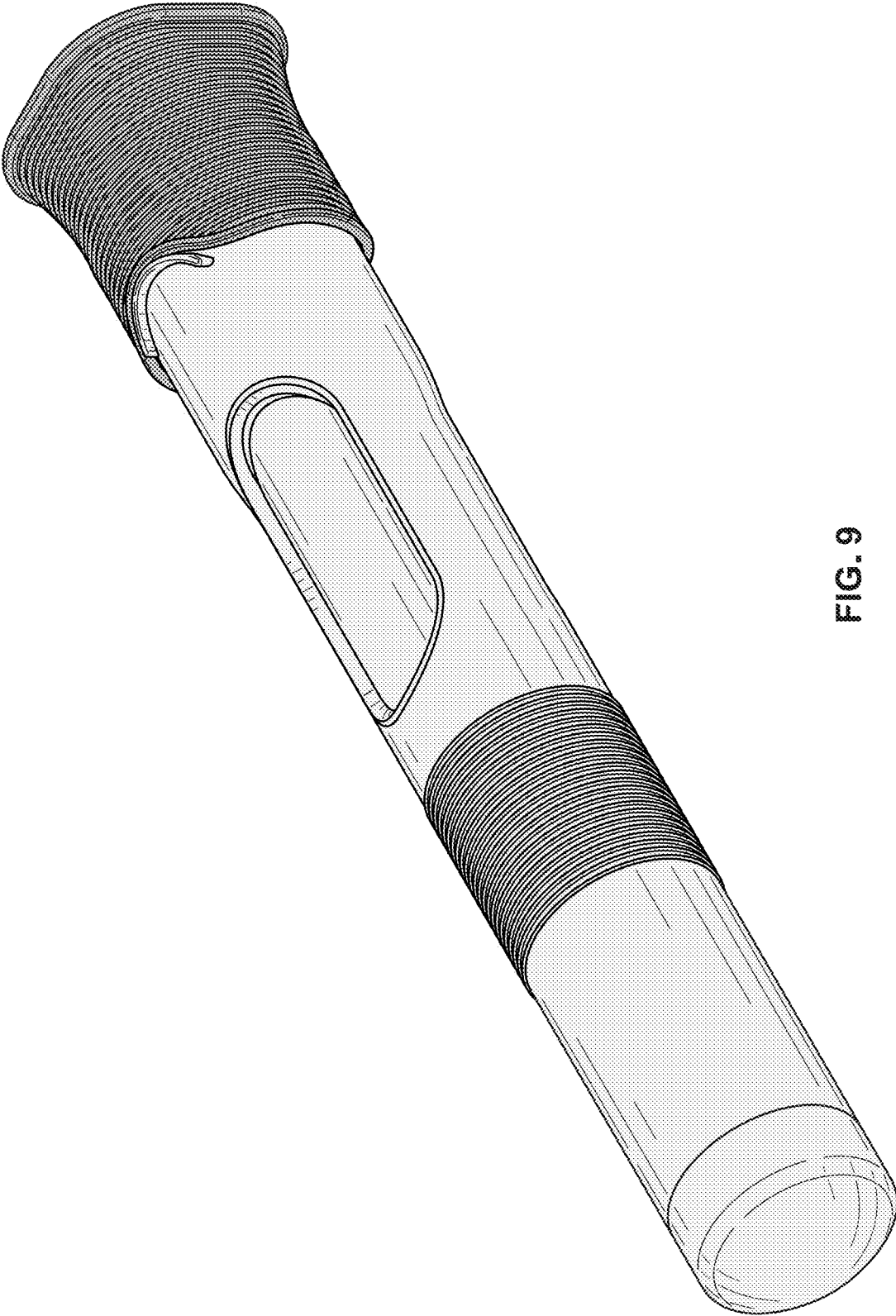

FIG. 9

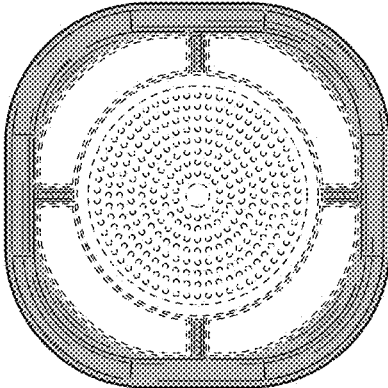

FIG. 10

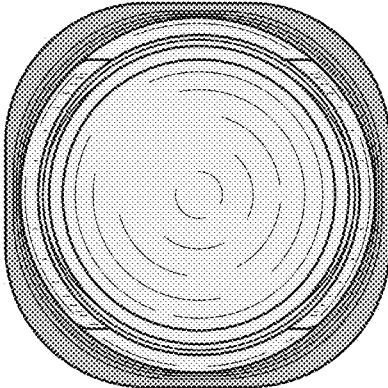

FIG. 11

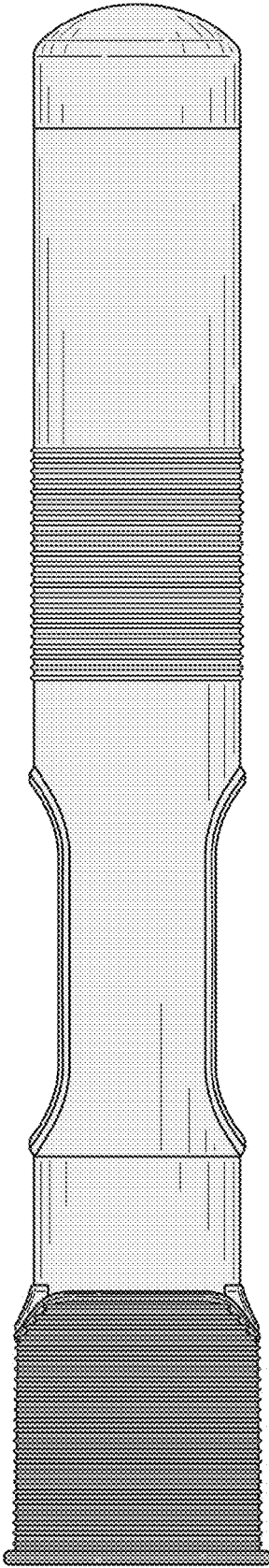

FIG. 12

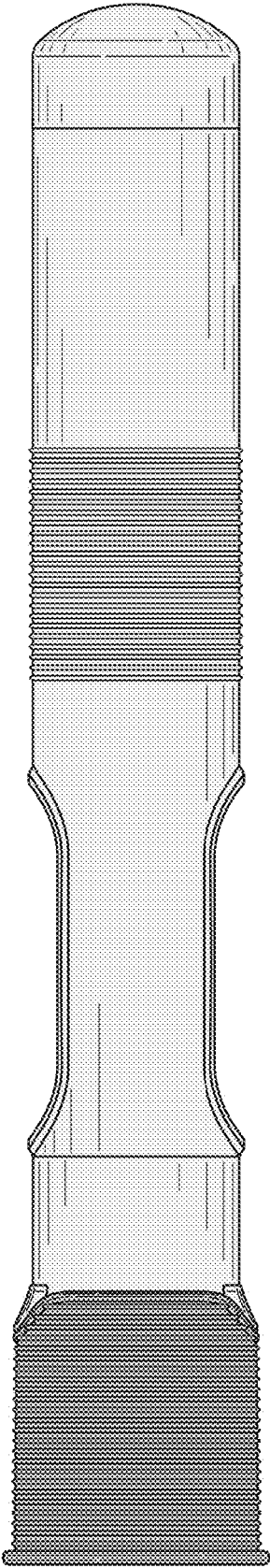

FIG. 13

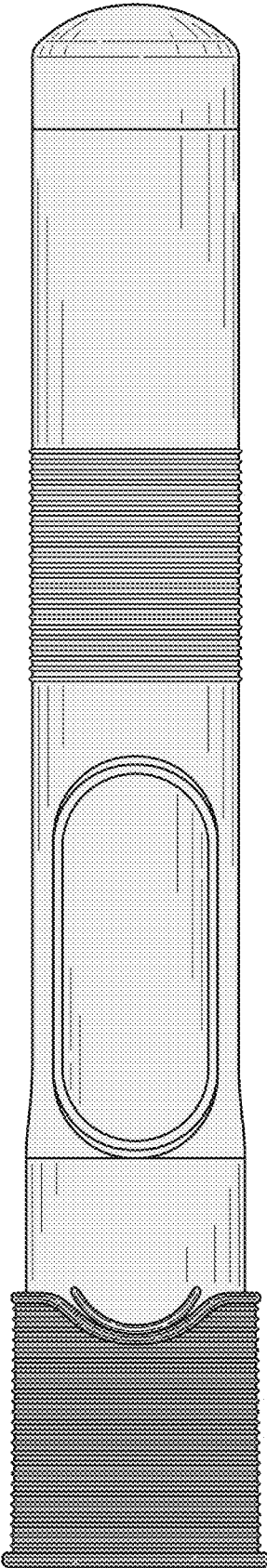

FIG. 14

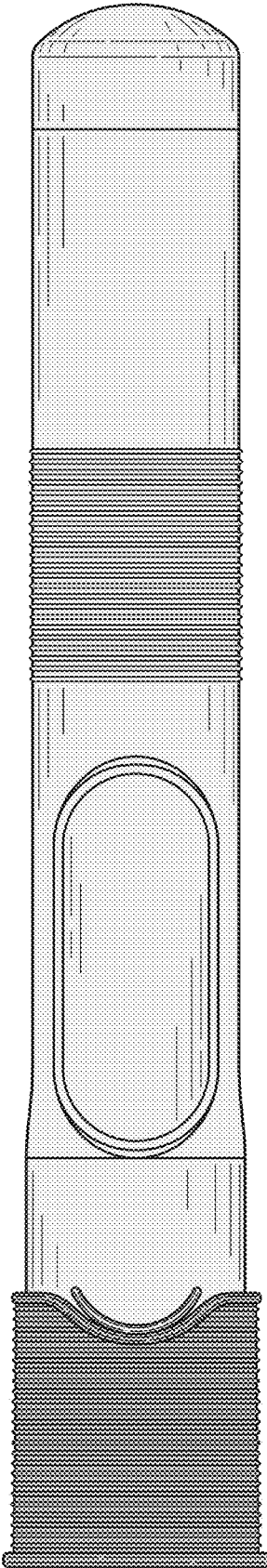

FIG. 15

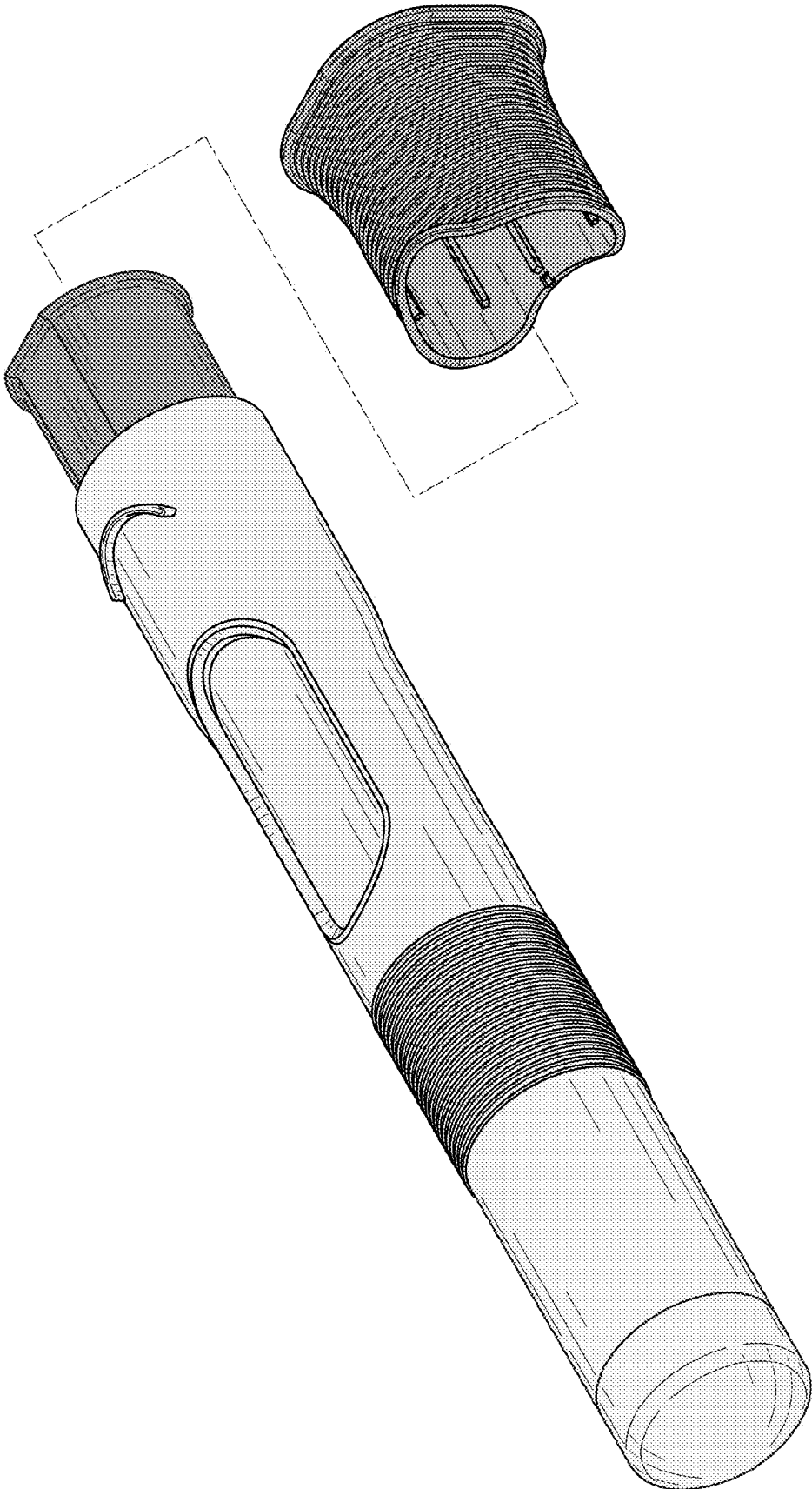

FIG. 16

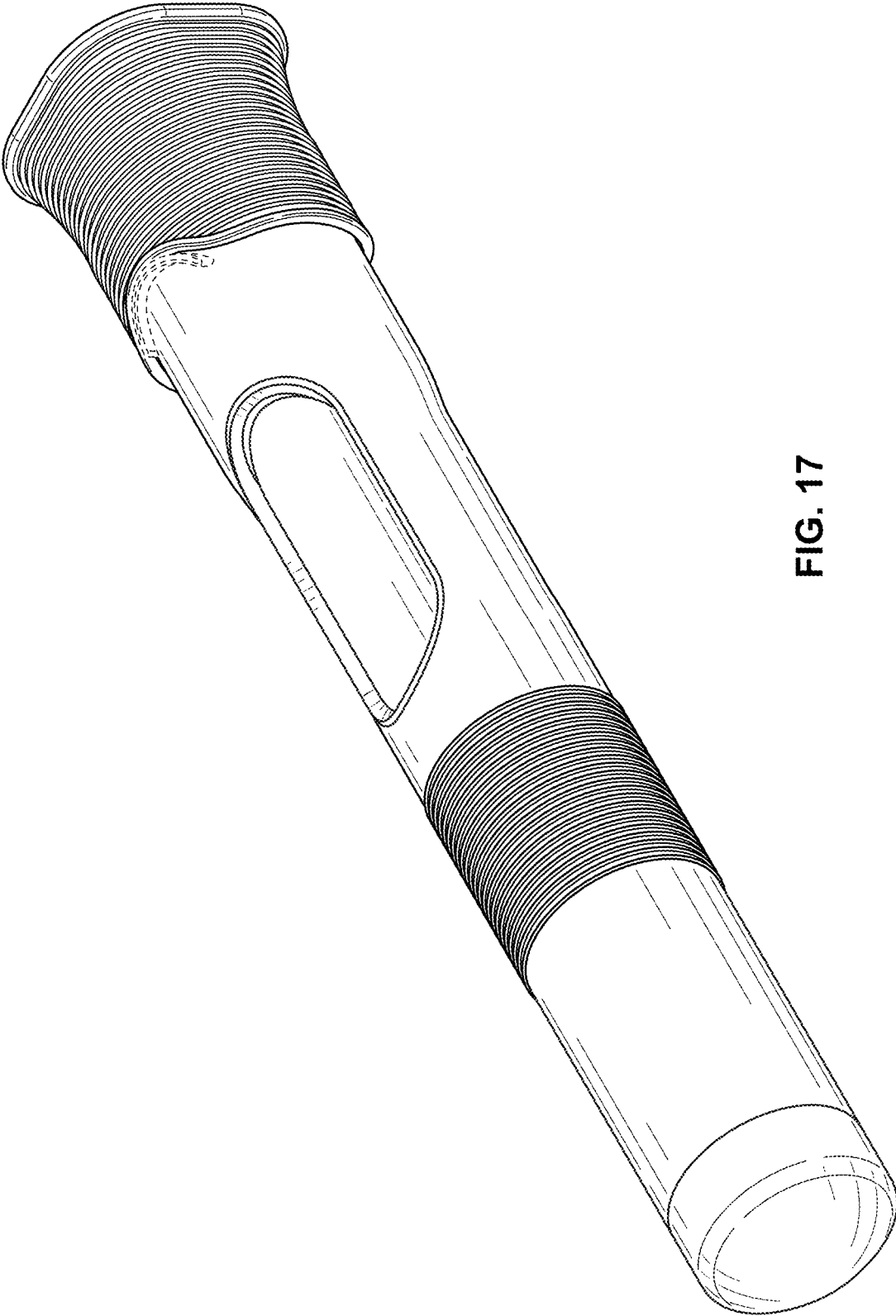

FIG. 17

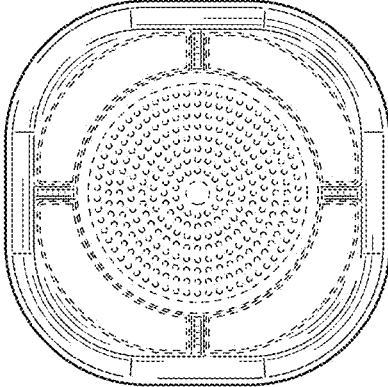

FIG. 18

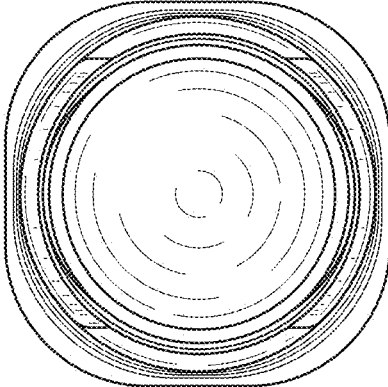

FIG. 19

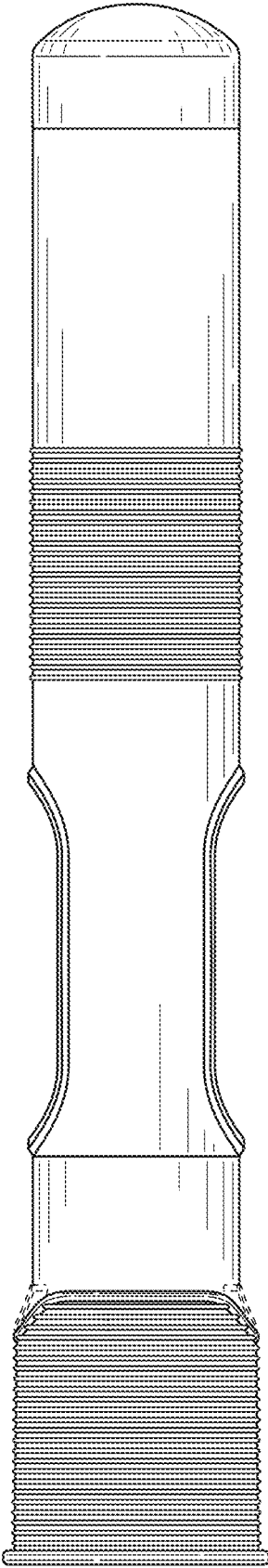

FIG. 20

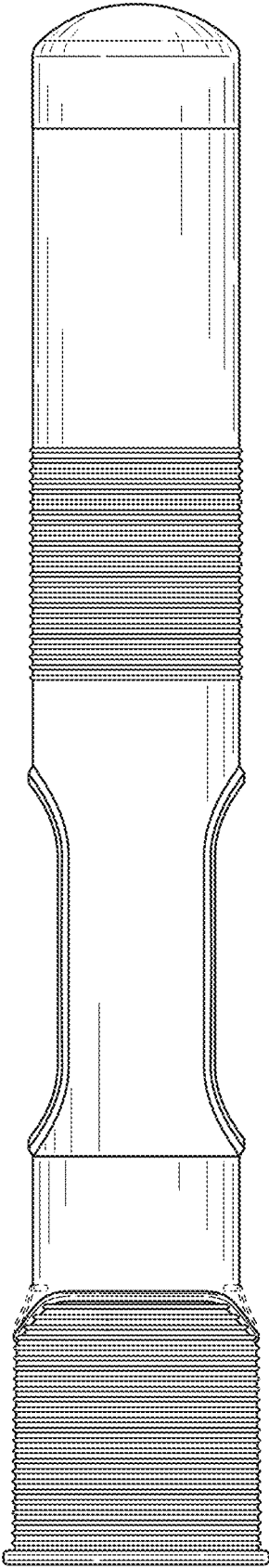

FIG. 21

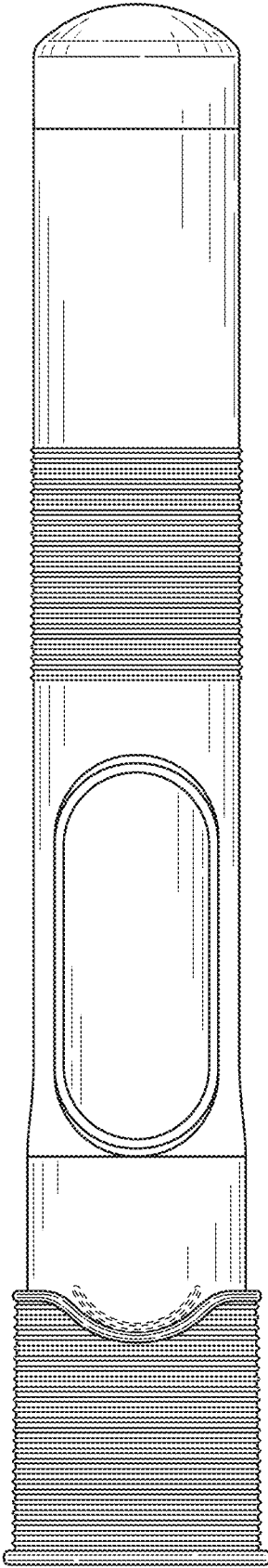

FIG. 22

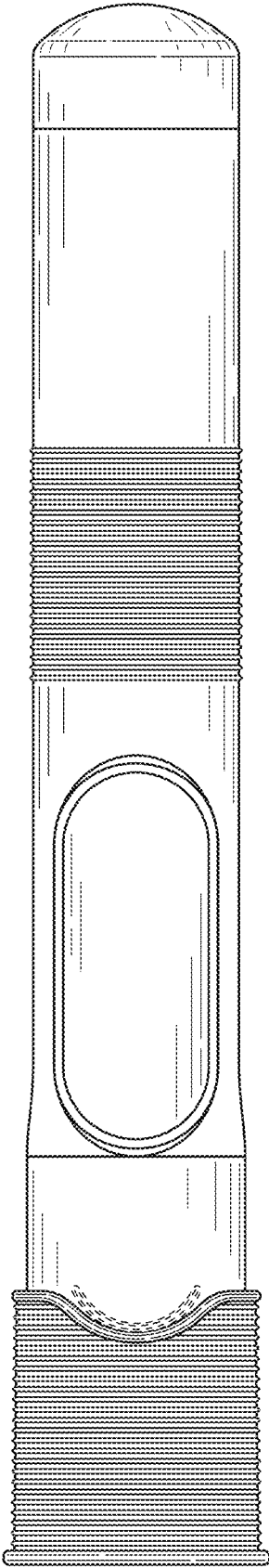

FIG. 23

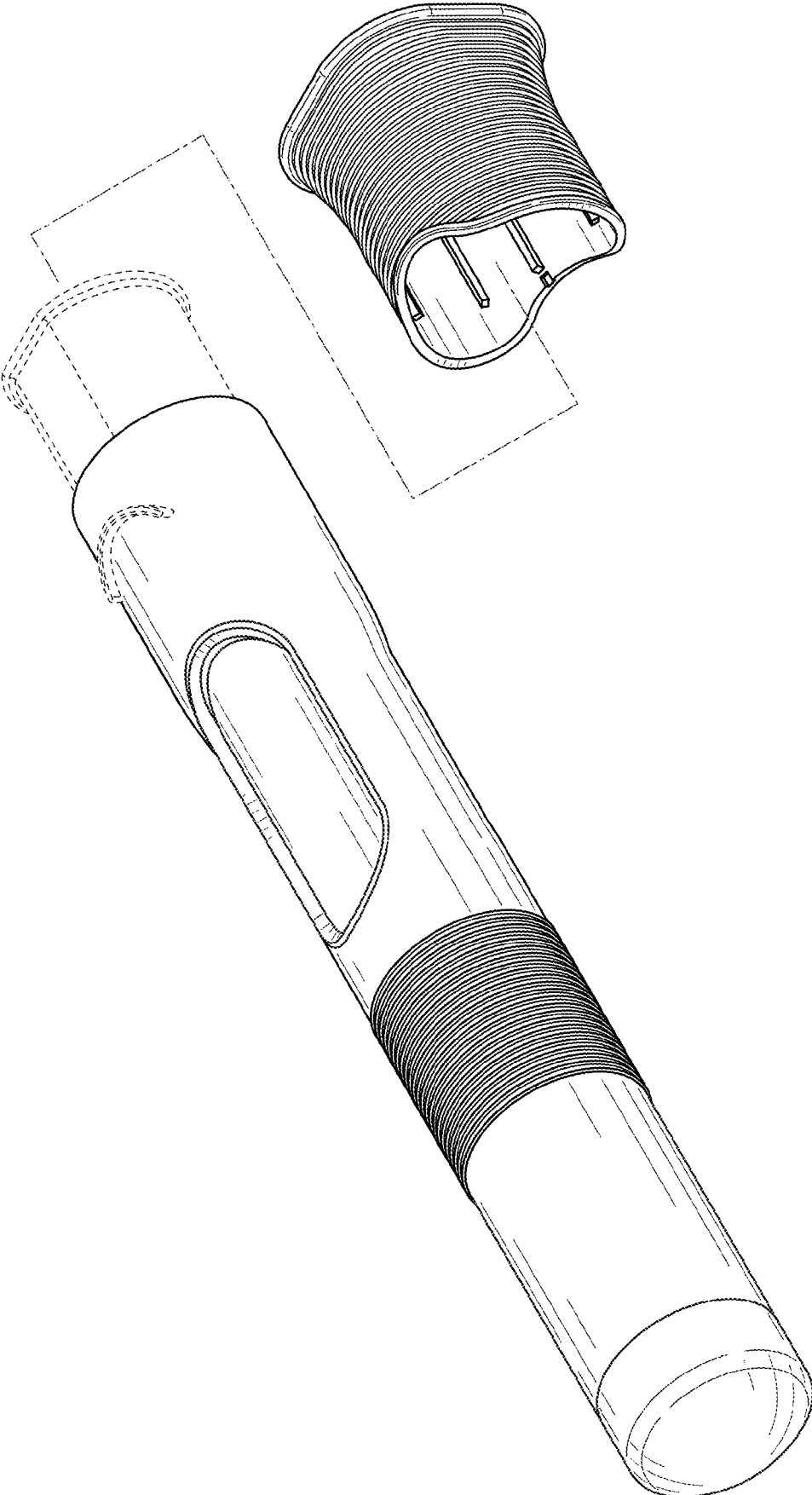

FIG. 24