



US 20140158144A1

(19) **United States**

(12) **Patent Application Publication**
Kaljura et al.

(10) **Pub. No.: US 2014/0158144 A1**
(43) **Pub. Date: Jun. 12, 2014**

(54) **SMOKING ARTICLE**

Publication Classification

(75) Inventors: **Karl Kaljura**, London (GB); **John Richardson**, London (GB); **Kevin Blick**, London (GB)

(51) **Int. Cl.**
A24D 3/04 (2006.01)
A24C 5/47 (2006.01)

(73) Assignee: **BRITISH AMERICAN TOBACCO (INVESTMENTS) LIMITED**, London (GB)

(52) **U.S. Cl.**
CPC .. *A24D 3/043* (2013.01); *A24C 5/47* (2013.01)
USPC **131/280**; 131/336

(21) Appl. No.: **14/233,707**

(57) **ABSTRACT**

(22) PCT Filed: **Jul. 17, 2012**

(86) PCT No.: **PCT/GB2012/051703**

§ 371 (c)(1),
(2), (4) Date: **Feb. 25, 2014**

(30) **Foreign Application Priority Data**

Jul. 20, 2011 (GB) 1112466.6

A smoking article **10** comprises a source of smokable material **11**, a filter **12**, a first layer **13** surrounding at least a part of the filter **12**, a second layer **14** surrounding at least a part of the first layer **13** and one or more paths **15** for ventilating air flow between the first and second layers **13, 14**. A part of the first layer **13** surrounds the source of smokable material **11** and is for attaching the filter **12** thereto.

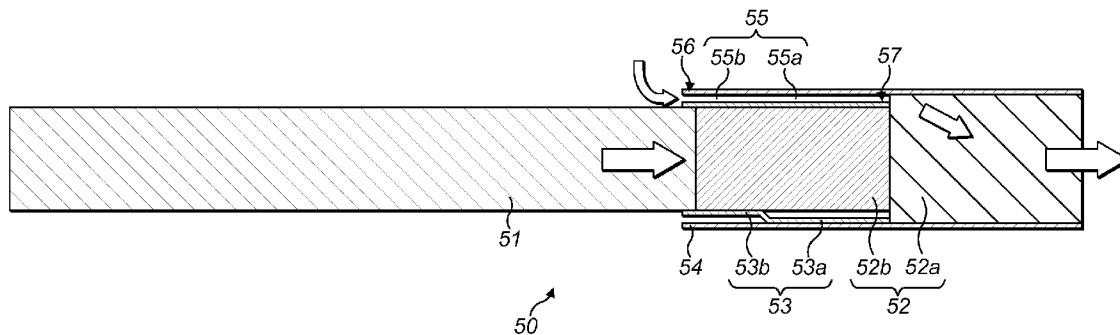

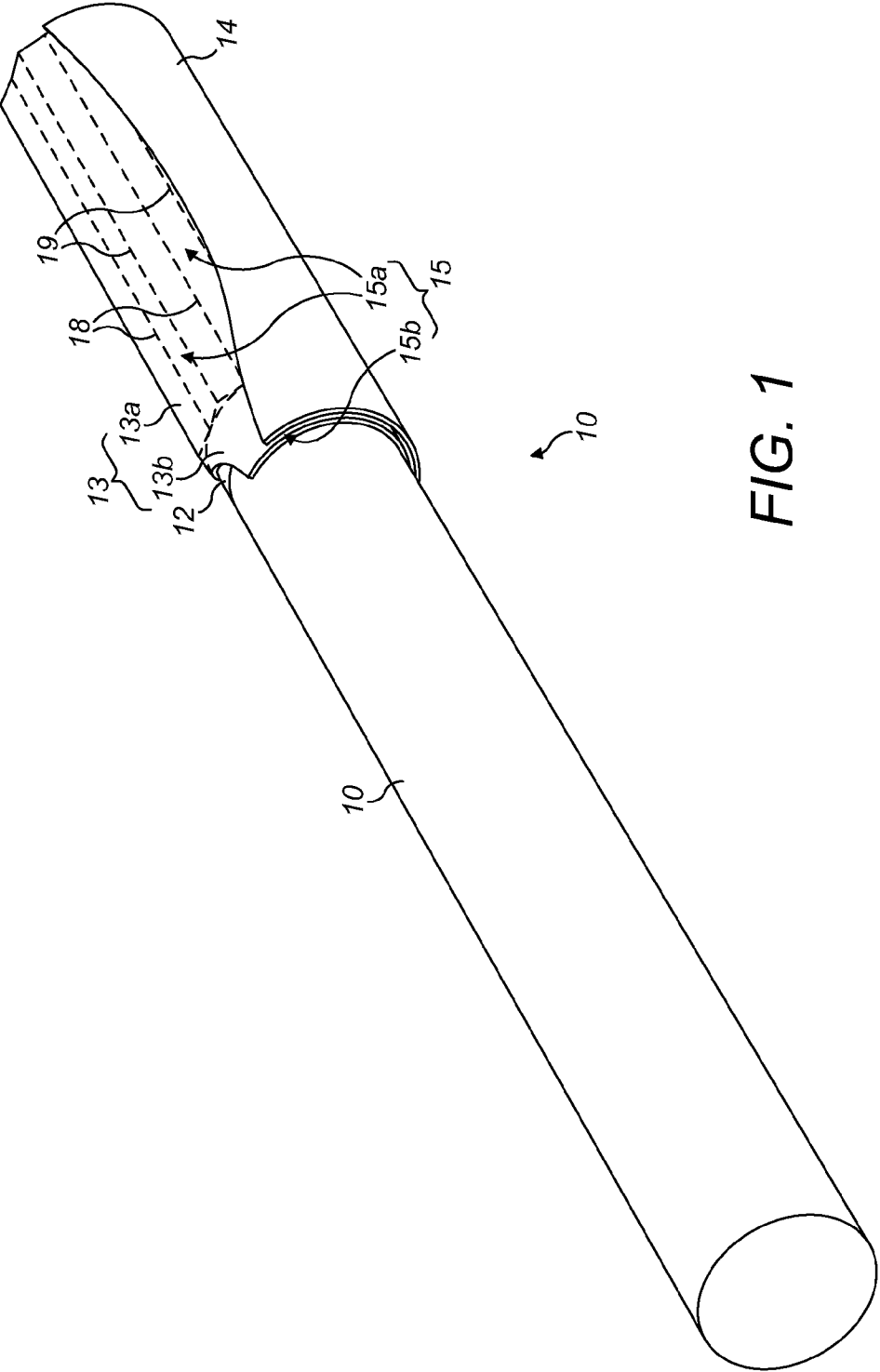

FIG. 1

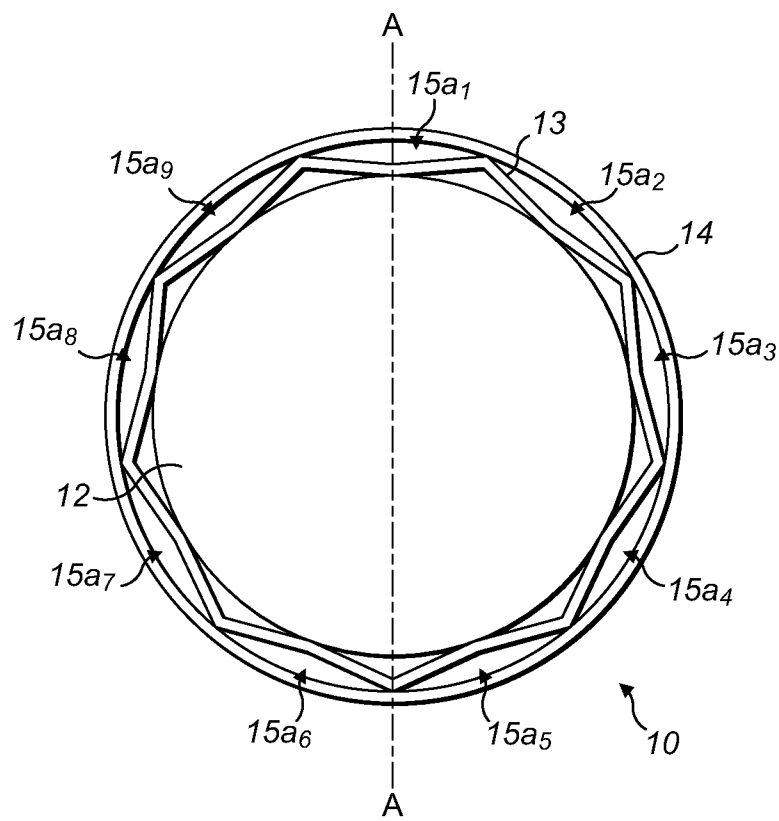

FIG. 2

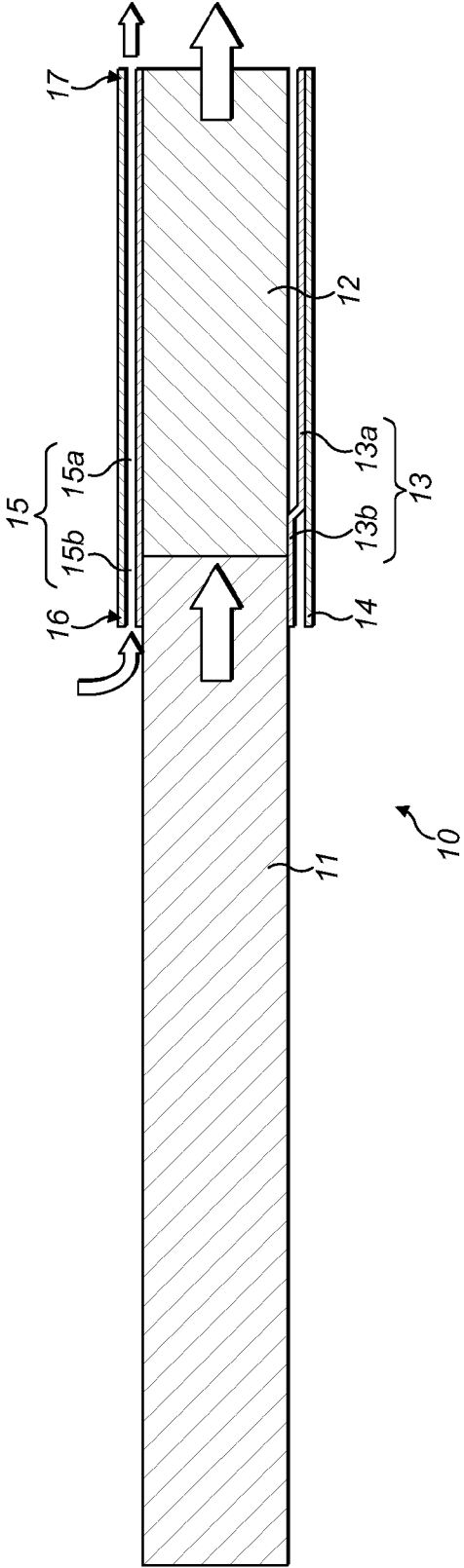

FIG. 3

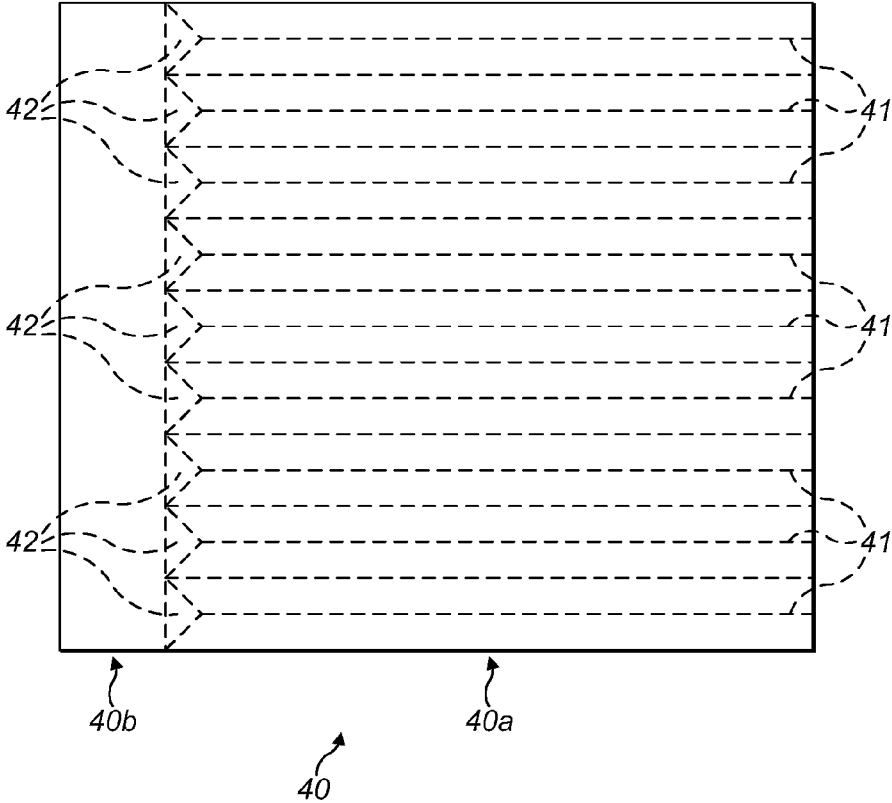

FIG. 4

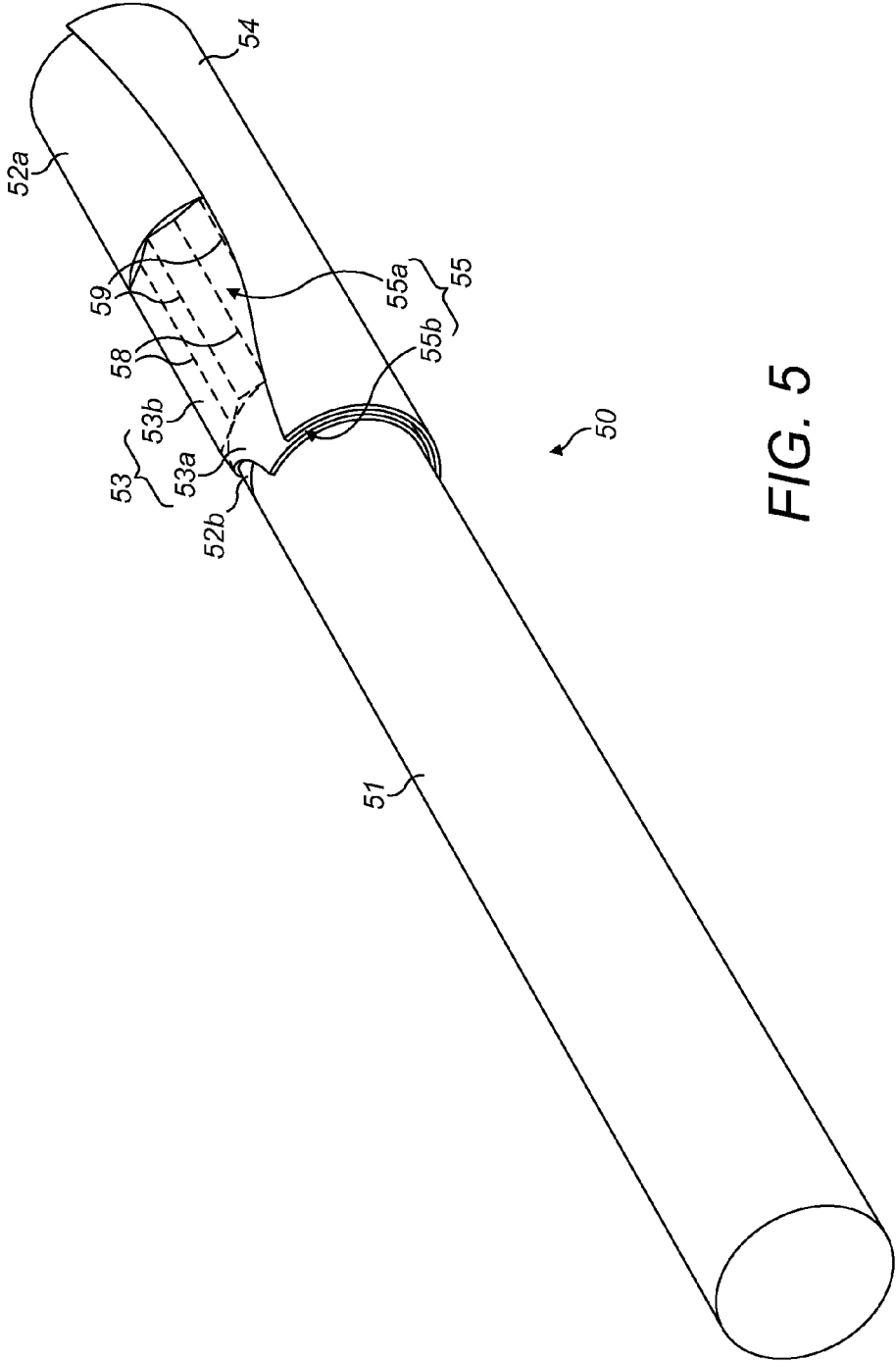

FIG. 5

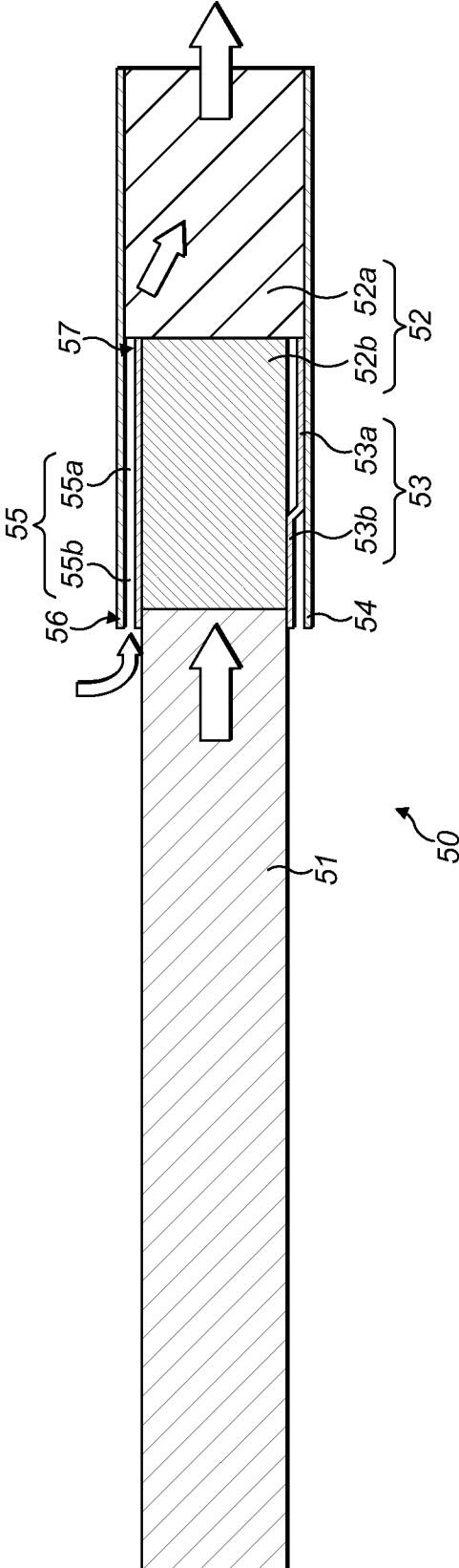

FIG. 6

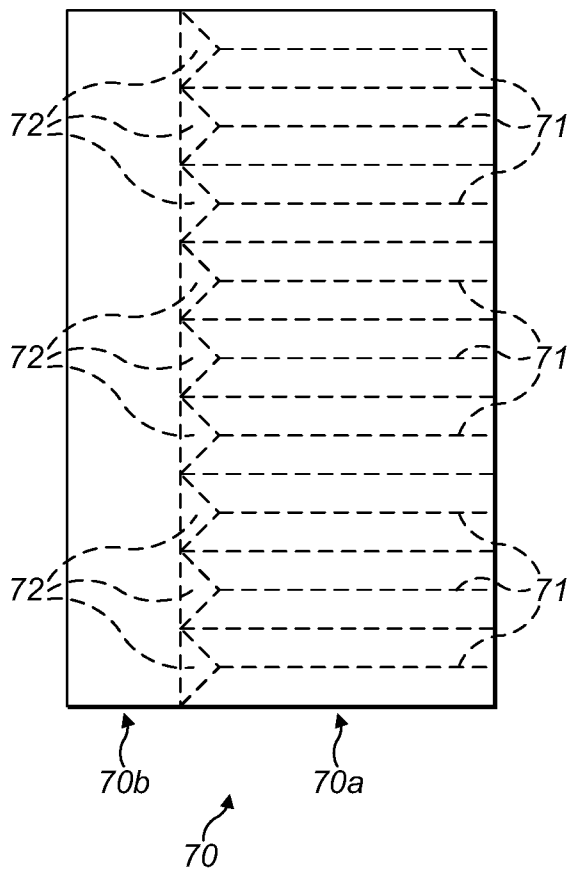

FIG. 7

SMOKING ARTICLE

FIELD

[0001] The invention relates to a smoking article and a method of manufacture of a smoking article.

BACKGROUND

[0002] As used herein, the term “smoking article” includes smokable products such as cigarettes, cigars and cigarillos whether based on tobacco, tobacco derivatives, expanded tobacco, reconstituted tobacco or tobacco substitutes and also heat-not-burn products (i.e. products in which flavour is generated from a smoking material by the application of heat without causing combustion of the material). Typically, smoking articles are provided with filters for removing constituents from the smoke.

[0003] It can be desirable to introduce ventilating air into the smoke. Known ways of doing so involve providing ventilation holes in the outside of the filter. The ventilation holes can be provided relatively straightforwardly but have various disadvantages including, for example, that they are prone to being accidentally blocked by the user’s fingers. It is also known to provide grooves in the filter for smoke or ventilating air flow. However, smoking articles including grooved filters can be complex and expensive to manufacture.

SUMMARY

[0004] The invention provides, in a first aspect, a smoking article comprising a source of smokable material, a filter, a first layer surrounding at least a part of the filter, a second layer surrounding at least a part of the first layer and one or more paths for ventilating air flow between the first and second layers, wherein a part of the first layer surrounds the source of smokable material and is for attaching the filter thereto.

[0005] Thus, the invention can provide an effective and efficient way of including paths for ventilating air flow in a smoking article, namely between a first layer, which is also for attaching the filter to the source of smoking material, and a surrounding second layer.

[0006] The invention provides, in a second aspect, a smoking article comprising a source of smokable material, a filter, a first layer surrounding at least a part of the filter, a second layer surrounding at least a part of the first layer and one or more paths for ventilating air flow between the first and second layers, wherein at least a part of the one or more paths is located further from an axis of the smoking article than any part of the filter or of the source of smokable material.

[0007] At least a part of the first layer may comprise an irregular outer surface that defines, together with the second layer, the one or more paths. The one or more paths may have one or more air outlets located near to the end of the filter furthest from the source of smokable material. The one or more paths may have one or more air outlets into the filter. The first layer and/or the second layer may be formed from a sheet material.

[0008] The invention provides, in a third aspect, a method of manufacturing a smoking article, the method comprising providing a source of smokable material, providing a filter, surrounding at least a part of the filter with a first layer, surrounding at least a part of the first layer with a second layer, and forming one or more paths for ventilating air flow between the first and second layers, wherein a part of the first

layer surrounds the source of smokable material and is for attaching the filter thereto, or wherein at least a part of the one or more paths is located further from an axis of the smoking article than any part of the filter or of the source of smokable material.

BRIEF DESCRIPTION OF THE DRAWINGS

[0009] Embodiments of the present invention will now be described, by way of example only, with reference to the accompanying drawings, in which:

[0010] FIG. 1 is a partially-cut-away perspective view of a smoking article according to a first embodiment of the invention;

[0011] FIG. 2 is an end view of the mouth end of the smoking article of FIG. 1;

[0012] FIG. 3 is a sectional view of the smoking article of FIG. 1 along the line A-A' of FIG. 2;

[0013] FIG. 4 is a plan view of an element used to form the inner covering layer of the smoking article of FIG. 1;

[0014] FIG. 5 is a partially-cut-away perspective view of a smoking article according to a second embodiment of the invention;

[0015] FIG. 6 is a sectional view of the smoking of FIG. 5;

[0016] FIG. 7 is a plan view of an element used to form the inner covering layer of the smoking article of FIG. 5.

DETAILED DESCRIPTION

First Embodiment

[0017] FIGS. 1, 2 and 3 show a smoking article 10 according to a first embodiment of the invention. The smoking article 10 includes a source of smokable material, which is preferably tobacco, in the form of a tobacco rod 11. The smoking article 10 further includes a filter 12 co-axially attached to the tobacco rod 11. An inner covering layer 13 is provided around the filter 12 and around a length of the tobacco rod 11. An outer covering layer 14 is provided around the inner covering layer 13. One or more channels 15 are formed between the inner and the outer covering layers 13, 14. The one or more channels 15 form one or more paths for the flow of ventilating air from the vicinity of the end of the filter 12 which is nearest to the tobacco rod 11 towards the other end of the filter 12. The end of the filter 12 nearest to the tobacco rod 11 will be referred to hereinafter as the “tobacco end” of the filter 12. The other end of the filter 12 will be referred to hereinafter as the “mouth end” of the filter 12.

[0018] The tobacco rod 11 and the filter 12 are preferably both cylindrical and preferably both have substantially the same outer diameter. The filter 12 includes filtration material, preferably surrounded by a sheet material, e.g. plugwrap (not shown). The plugwrap is preferably porous, i.e. permeable to fluid flow, but may be non-porous. The filtration material is preferably cellulose acetate tow, bonded together with a plasticiser. The filtration material is preferably homogeneous. The term “homogenous” is used to mean that the filtration material is substantially uniform throughout the filter 12. The filter 12 may include an additive such as a smoke modifying agent, e.g. activated charcoal. The filter 12 is preferably a standard filter but may be any other type of filter, e.g. a composite filter.

[0019] The inner covering layer 13 preferably encircles, at least once, the whole length of the filter 12 and a length of the tobacco rod 11 adjacent to the filter 12. The inner covering

layer 13 is preferably adhered to and/or secured around the filter 12 and the tobacco rod 11, as will be described in more detail below. The inner covering layer 13 is preferably formed from a sheet material, which is preferably a paper. In some embodiments, the sheet material is made of a non-porous plug wrap which has longer fibre lengths and is more resistant to cracking or splitting when embossed. Alternatively, the inner covering layer 13 may be formed from a relatively thick tipping paper or any type of tipping paper or any other suitable material, such as a plastics material, a metal foil or a metallized paper. The inner covering layer 13 is preferably substantially non-porous, i.e. impermeable to fluid flow.

[0020] The inner covering layer 13 preferably forms an elongate cylindrical tube which is longitudinally divided into an irregular portion 13a and a regular portion 13b. The portions 13a and 13b are preferably formed from a single piece of the sheet material.

[0021] The regular portion 13b of the inner covering layer 13 preferably encircles, at least once, a length of the filter 12 adjacent to the tobacco rod 11 and an adjacent length of the tobacco rod 11. The regular portion 13b is preferably adhered, at least in part, to the outer surfaces of the lengths of the filter 12 and the tobacco rod 11. The inner covering layer 13 is also preferably secured around the lengths of the filter 12 and the tobacco rod 11 by a longitudinal seam of adhesive joining opposite edges. Hence the regular portion 13b joins the filter 12 to the tobacco rod 11 and also helps to form a seal against ingress of external air into the tobacco end of the filter 12 during use, i.e. when the user draws on the smoking article 10. Since the inner surface of the regular portion 13b of the inner covering layer 13 and the outer surfaces of the filter 12 and the tobacco rod 11 are all preferably smooth, this can help to provide a good join and a good seal.

[0022] The irregular portion 13a of the inner covering layer 13 preferably encircles, at least once, the length of the filter 12 that is not encircled by the regular portion 13b. Hence the irregular portion 13a preferably extends to the mouth end of the filter 12. However, the irregular portion 13a need not extend to, or may extend beyond, the mouth end of the filter 12. The irregular portion 13a is preferably secured around the filter 12 by a longitudinal seam of adhesive joining opposite edges. The irregular portion 13a is also preferably adhered, at least in part, to the outer surface of the filter 12.

[0023] The irregular portion 13a of the inner covering layer 13 is shaped so as to define, in combination with the outer covering layer 14, the one or more channels 15.

[0024] The channels 15 are adapted to deliver ventilating air from near to the tobacco end of the filter 12 to near to the mouth end of the filter 12. The ventilating air is from the atmosphere around the smoking article 10. The ventilating air that is delivered to the mouth end of the filter 12 mixes with, and thus dilutes, the smoke which is drawn through the tobacco rod 11 and the filter 12. The mixing takes place outside the smoking article 10, e.g. in the user's mouth. The channels 15 preferably each have one or more air inlets 16 near to the tobacco end of the filter 12 and one or more air outlets 17 near to the mouth end of the filter 12.

[0025] The irregular portion 13a preferably has a corrugated outer surface, particularly a surface having one or more elongate grooves 18 separated by ridges 19. The ridges 19 are preferably raised in relation to the regular portion 13b of the inner covering layer 13.

[0026] The grooves 18 preferably all extend substantially parallel to each other and parallel to the longitudinal axis of

the filter 12. However, the grooves 18 may extend in one or more different directions. For example, they may follow one or more helical paths or one or more sinuous paths along the filter 12. Such paths can provide a way of increasing the path length and hence increasing the pressure drop along the path. The pressure drop along the path determines the ventilation properties, as will be described in more detail below.

[0027] The grooves 18 are preferably equally spaced around the circumference of the filter 12. There are preferably between eight and ten grooves 18 spaced around the circumference. However, there may be fewer grooves 18, e.g. one, two, or four grooves 18, or more grooves 18, e.g. eighteen or thirty-six grooves 18. The grooves 18 are preferably spaced around the whole circumference of the filter 12 but may be spaced around one or more parts of the circumference.

[0028] The ridges 19 and the grooves 18 preferably each have a pointed profile so as to form a triangular or sawtooth overall profile. However, the profile of the ridges 19 and/or the grooves 18 may be different. For example, the ridges 19 and the grooves 18 may both be curved, thereby forming a sinuous overall profile. The ridges 19 may be pointed and the grooves 18 may be curved or vice versa, thereby forming a fluted overall profile. The ridges 19 and/or the grooves 18 may include one or more substantially flat portions. For example, they may form a castellated overall profile. The ridges 19 and the grooves 18 preferably have a constant profile but may have a profile which varies along the length and/or around the circumference of the filter 12. For example, the width of the grooves 18 may increase or decrease gradually towards the mouth end of the filter 12.

[0029] The width of the grooves 18 and the height of the grooves 18 are preferably selected so as to provide the desired ventilation, as will be described in more detail below.

[0030] The outer covering layer 14 preferably encircles, at least once, the whole length of the inner covering layer 13. However, the outer covering layer 14 need not extend to, or may extend beyond, one or both ends of the inner covering layer 13. The outer covering layer 14 is preferably formed from a sheet material, which is preferably a standard tipping paper. However, the outer covering layer 14 may be formed from any suitable material, such as a plastics material, a metal foil or a metallized paper. The outer covering layer 14 is preferably substantially non-porous.

[0031] The outer covering layer 14, in combination with the inner covering layer 13, defines the one or more channels 15. The outer covering layer 14 preferably forms a substantially smooth cylindrical tube around the inner covering layer 13. In particular, the outer covering layer 14 preferably forms a substantially smooth cylindrical tube enveloping the ridges 19 (or other protrusions) provided on the irregular portion 13a of the inner covering layer. Thus, channels 15a₁, 15a₂, . . . , 15a_n, are formed in the spaces between the inner and the outer covering layers 13, 14, in the grooves 18 in the irregular portion 13a of the inner covering layer 13. An annular space 15b is also formed between the inner and the outer covering layers 13, 14 where the outer covering layer 14 extends over the regular portion 13b of the inner covering layer 13.

[0032] The channels 15a preferably have respective outlets 17 at their ends nearest to the mouth end of the filter 12. The inner and the outer covering layers 13, 14 preferably both extend to the end of the filter 12 and so the outlets 17 are preferably located at the end of the filter 12. However, the inner and/or the outer covering layers 13, 14 may have different extents, as described above, and so the outlets 17 may

have different locations. Nevertheless, the outlets **17** are preferably located such that, when the user places the smoking article **10** in the mouth, the outlets **17** will also be in the mouth. Thus, when the user draws on the smoking article **10**, ventilating air is drawn through the channels **15a**.

[0033] The annular space **15b** has an annular opening at its end away from the channels **15a**. This annular opening forms an inlet **16** for the ventilating air. The annular space **15b** is also in fluid communication with each of the channels **15a**. However, the outer covering layer **14** need not extend over the regular portion **13b** of the inner covering layer **13** and so there may be no annular space. In this case, the channels **15a** have respective inlets **16** for ventilating air which are located where the outer covering layer **14** ends.

[0034] The outer covering layer **14** is preferably secured around the inner covering layer **13** by a longitudinal seam of adhesive joining opposite edges. The outer covering layer **14** is also preferably adhered, at least in part, to the ridges **19** (or other protrusions) provided on the irregular portion **13a** of the inner covering layer **13**.

[0035] Instead of the corrugated outer surface described above, the irregular portion **13a** of the inner covering layer **13** may have any shape which, in combination with the outer covering layer **14**, forms the channels **15** between the inner and the outer covering layers **13**, **14**. For example, the irregular portion **13a** may include isolated protrusions upon which the outer covering layer **14** lies, thereby forming air flow paths in the regions between the protrusions.

[0036] In use, when the user draws on the smoking article **10**, smoke and air is drawn through the tobacco rod **11** and then the filter **12**, and ventilating air is drawn through the channels **15**.

[0037] The properties of the channels **15** are preferably selected so as to provide the desired ventilation. In particular, the draw resistance of the channels **15** is determined by, amongst other things, their number, cross-sectional area, length and shape. For example, a larger number of channels **15** and/or larger channels **15** will have a smaller resistance to the flow of air. This resistance is preferably selected, in relation to the flow resistance through the tobacco rod **11** and the filter **12**, so as to provide the desired ventilation. For example, if the resistance of the channels **15** is lower in relation to the resistance of the tobacco rod **11** and the filter **12**, then the amount of air drawn through the channels **15** in relation to the amount of smoke and air drawn through the filter **12** will be higher and so the smoke will be more diluted. Conversely, if the resistance of the channels **15** is higher in relation to the resistance of the tobacco rod **11** and the filter **12**, then the amount of air drawn through the channels **15** in relation to the amount of smoke and air drawn through the filter **12** will be lower and so the smoke will be less diluted.

[0038] The smoking article **10** can have the advantage that the inlets **16** for ventilating air are less likely to be occluded by the user's fingers. The inlets **16** are preferably positioned near to the tobacco end of the filter **12**, or even beyond the tobacco end of the filter **12**, and so are away from usual holding position of the user's fingers. Furthermore, the inlets **16** are preferably orientated such that they face longitudinally along the smoking article **10** and so, even if the fingers are positioned near to the inlets **16**, the fingers are still unlikely to occlude the inlets **16**. In contrast, known smoking article including a plurality of vent holes in the tipping paper can have the disadvantage that the vent holes can be relatively

easily occluded by the user's fingers. This can have a negative effect on the consistency of the smoke which is delivered to the user.

[0039] The smoking article **10** can also have the advantage of providing more effective filtration performance. This is because the ventilating air is mixed with the smoke outside the filter **12**. In contrast, known smoking articles in which the ventilating air is introduced into the filter **12** can have the disadvantage that the introduced ventilating air increases the flow rate towards the mouth end of the filter **12**, and therefore reduces the residence time of the smoke. This can have a negative effect on the filtering performance.

[0040] Because the filter **12** is preferably completely covered by the inner and the outer covering layers **13**, **14**, the smoking article **10** can also have the advantage that a reduced amount of smoke will come into contact with the user's fingers. This is because the inlets are away from usual holding position of the user's fingers. In contrast, in known smoking articles including a plurality of vent holes in the tipping paper, smoke can exit the vent holes and come into contact with the user's fingers, e.g. when the user is not drawing on the smoking article.

[0041] FIG. 4 shows a sheet **40** for forming the inner covering layer **13** of the smoking article **10**. The sheet is preferably formed from a standard tipping paper, as described above. The sheet is preferably rectangular and is divided into two rectangular portions, namely an irregular portion **40a** and a regular portion **40b**. The irregular portion **40a** corresponds to the irregular portion **13a** of the inner covering layer **13**. The regular portion **40b** corresponds to the regular portion **13b** of the inner covering layer **13**.

[0042] The irregular portion **40a** has a profile as described above in relation to the irregular portion **13a** of the inner covering layer. The profile preferably has a plurality of raised pointed ridges **41**, as described above. The raised pointed ridges **41** preferably each have an oblique, triangular side wall **42** at their ends nearest to the regular portion **40b** of the sheet **40**. However, the sidewall **42** may be substantially perpendicular to the regular portion **40b** of the sheet **40** and/or may have a different shape.

[0043] The profile of the irregular portion **40a** of the sheet **40** is preferably formed by embossing. The embossing is preferably carried out using methods which will be known per se to persons skilled in the art. However, the profile may be formed using a method other than embossing. For example, if the sheet **40** is formed from a plastics material, then this may be moulded to form the profile. The whole thickness of the sheet **40** is preferably formed into the corrugations or irregularities **41**. Hence the top and bottom surfaces of the sheet **40** will both have a similar, irregular profile. This is particularly suitable where the sheet **40** is formed from a tipping paper. However, the corrugations or irregularities **41** may be formed only towards the top surface of the sheet **40**, and the bottom surface of the sheet may be substantially smooth. This is particularly suitable where the sheet **40** is formed from a relatively thick material.

[0044] The smoking article **10** can be manufactured using a method in which the tobacco rod **11** is joined to the filter **12** by means of the inner covering layer **13**, which is preferably adhered to and/or secured around the filter **12** and the tobacco rod **11**, as described above. The sheet **40** for forming the inner covering layer **13** is preferably embossed (or otherwise shaped) prior to being wrapped around the filter **12** and the

tobacco rod **11**. The outer covering layer **14** is then preferably wrapped around and adhered to and/or secured around the inner covering layer **13**.

[0045] The smoking article **10** can also be manufactured using a method in which two tobacco rods **11** are simultaneously joined to each end of a double length of the filter **12** and the resulting article is then cut into two halves to form two smoking articles **10**. In this case, a double length of the sheet **40** for forming the inner covering layer **13** and a double length of a sheet for forming the outer covering layer **14** are preferably used. The double length of the sheet **40** for forming the inner covering layer **13** preferably has the regular portion **40b** at either end and an intermediate double length of the irregular portion **40a**.

[0046] A sheet having a symmetrical arrangement of regular and irregular portions is generally preferable since the sheet can be wrapped more effectively, for example without the slewing or creasing that can occur when a sheet having a non-symmetric arrangement is used.

[0047] The smoking article **10** can be manufactured efficiently because its formation preferably largely consists of wrapping layers of sheet material around the filter **12** and the tobacco rod **11** and because the wrapping processes themselves can be carried out efficiently. Furthermore, the smoking article **10** can be manufactured using methods and apparatuses which are based upon existing methods and apparatuses. The apparatus may include first and second tipping sections for providing the inner and outer covering layers **13**, **14** respectively.

Second Embodiment

[0048] FIGS. **5** and **6** show a smoking article **50** according to a second embodiment of the invention. The smoking article **50** includes a source of smokable material, which is preferably tobacco, in the form of a tobacco rod **51**. The smoking article **50** further includes a filter **52** co-axially attached to the tobacco rod **51**. The filter **52** is longitudinally divided into two filter parts, namely a mouth-end filter part **52a** and a tobacco-end filter part **52b**. An inner covering layer **53** is provided around the filter **52** and around a length of the tobacco rod **51**. An outer covering layer **54** is provided around the inner covering layer. One or more channels **55** are formed between the inner and the outer covering layers **53**, **54**. The one or more channels **55** form one or more paths for the flow of ventilating air from near to the tobacco end of the filter to one or more intermediate locations in the filter.

[0049] The tobacco rod **51** and the two filter parts **52a**, **52b** are preferably all cylindrical. The tobacco rod **51** and the tobacco-end filter part **52b** preferably have substantially the same outer diameter. The mouth-end filter part **52a** preferably has a slightly larger outer diameter than the tobacco-end filter part **52b**, as will be described in more detail below. The two filter parts **52a**, **52b** each include filtration material, preferably surrounded by a sheet material, e.g. plugwrap (not shown). The plugwrap is preferably porous, but may be non-porous. The plugwrap need not be included. The filtration material is preferably cellulose acetate tow, bonded together with a plasticiser. The filtration material is preferably homogeneous. The term "homogeneous" is used to mean that the filtration material is substantially uniform throughout the filter **52**. The mouth-end and/or tobacco-end filter parts **52a**, **52b** may include an additive such as a smoke modifying agent, e.g. activated charcoal. The two filter parts **52a**, **52b**

may include different filtration materials, may be surrounded by different materials and may include different additives.

[0050] The inner covering layer **53** preferably encircles, at least once, the whole length of the tobacco-end filter part **52b** and an adjacent length of the tobacco rod **51**. The inner covering layer **53** is preferably adhered to and/or secured around the tobacco-end filter part **52b** and the tobacco rod **51**, as will be described in more detail below. The inner covering layer **53** is preferably formed from a sheet material, which is preferably a paper. In some embodiments, the sheet material is made of a non-porous plug wrap which has longer fibre lengths and is more resistant to cracking or splitting when embossed. Alternatively, the inner covering layer **53** may be formed from a relatively thick tipping paper or any type of tipping paper or any other suitable material, such as a plastics material, a metal foil or a metallized paper. The inner covering layer **53** is preferably substantially non-porous.

[0051] The inner covering layer **53** preferably forms an elongate cylindrical tube which is longitudinally divided into an irregular portion **53a** and a regular portion **53b**. The portions **53a** and **53b** are preferably formed from a single piece of the sheet material.

[0052] The regular portion **53b** of the inner covering layer **53** preferably encircles, at least once, a length of the tobacco-end filter part **52b** adjacent to the tobacco rod **51** and an adjacent length of the tobacco rod **51**. The regular portion **53b** is preferably adhered, at least in part, to the outer surfaces of the lengths of the tobacco-end filter part **52b** and the tobacco rod **51**. The regular portion **53b** is also preferably secured around the lengths of the tobacco-end filter part **52b** and the tobacco rod **51** by a longitudinal seam of adhesive joining opposite edges. Hence the regular portion **53b** joins the tobacco-end filter part **52b** to the tobacco rod **51** and also helps to form a seal against ingress of external air into the tobacco end of the filter **52**. Since the inner surface of the regular portion **53b** of the inner covering layer **53** and the outer surfaces of the tobacco-end filter part **52b** and the tobacco rod **51** are all preferably smooth, this can help to provide a good join and a good seal.

[0053] The irregular portion **53a** of the inner covering layer **53** preferably encircles, at least once, the length of the tobacco-end filter part **52b** that is not encircled by the regular portion **53b**. The two filter parts **52a**, **52b** preferably have a similar length and hence the inner covering layer **53** preferably extends to around halfway between the tobacco end and the mouth end of the filter **52**. For example, the filter **52** may be 27 mm in length and the irregular portion **53a** may extend to a distance of 13 mm from the mouth end of the filter **52**. However, the mouth-end filter part **52a**, tobacco-end filter part **52b** and/or the irregular portion **53a** may have different lengths. Also, the edge of the irregular portion **53a** nearest to the mouth end of the filter **52** may be obliquely angled and/or non-straight and hence the extent of the irregular portion **53a** towards the mouth end of the filter **52** may vary around the circumference of the filter **52**. As will be described below, the extent of the irregular portion **53a** determines the extent of the channels **55** and hence the location(s) at which the ventilating air is introduced into the filter **52**. The irregular portion **53a** is preferably secured around the tobacco-end filter part **52b** by a longitudinal seam of adhesive joining opposite edges. The irregular portion **53a** is also preferably adhered, at least in part, to the outer surface of the tobacco-end filter part **52b**.

[0054] The irregular portion **53a** of the inner covering layer **53** is shaped so as to define, in combination with the outer covering layer **54**, the one or more channels **55**.

[0055] The channels **55** are adapted to deliver ventilating air from near to the tobacco end of the filter **52** to one or more intermediate locations in the filter **52**. The one or more intermediate locations are preferable in the vicinity of where the filter part **52a**, **52b** meet. The ventilating air that is delivered to the intermediate locations enters the filter **52** and mixes with, and thus dilutes, the smoke which is drawn through the tobacco rod **51** and the filter **52**. The mixing takes place mainly in the filter **52**. The channels **55** preferably each have one or more air inlets **56** near to the tobacco end of the filter **52** and one or more air outlets **57** at the intermediate locations in the filter **52**.

[0056] The irregular portion **53a** preferably has a corrugated outer surface, particularly a surface having one or more elongate grooves **58** separated by ridges **59**. The ridges **59** are preferably raised in relation to the regular portion **53b** of the inner covering layer **53**.

[0057] The grooves **58** preferably all extend substantially parallel to each other and parallel to the longitudinal axis of the filter **52**. However, the grooves **58** may extend in one or more different directions. For example, they may follow one or more helical paths or one or more sinuous paths along the filter **52**. Such paths can provide a way of increasing the path length and hence increasing the pressure drop along the path.

[0058] The grooves **58** are preferably equally spaced around the circumference of the filter **52**. There are preferably between eight and ten grooves **58** spaced around the circumference. However, there may be fewer grooves **58**, e.g. one, two, or four grooves **58**, or more grooves **58**, e.g. eighteen or thirty-six grooves **58**. The grooves **58** are preferably spaced around the whole circumference of the filter **52** but may be spaced around one or more parts of the circumference.

[0059] The ridges **59** and the grooves **58** preferably each have a pointed profile so as to form a triangular or sawtooth overall profile. However, the profile of the ridges **59** and/or the grooves **58** may be different. For example, the ridges **59** and the grooves **58** may both be curved, thereby forming a sinuous overall profile. The ridges **59** may be pointed and the grooves **58** may be curved or vice versa, thereby forming a fluted overall profile. The ridges **59** and/or the grooves **58** may include one or more substantially flat portions. For example, they may form a castellated overall profile. The ridges **59** and the grooves **58** preferably have a constant profile but may have a profile which varies along the length and/or around the circumference of the filter **52**. For example, the width of the grooves **58** may increase or decrease gradually towards one end.

[0060] The width of the grooves **58** and the height of the grooves **58** are preferably selected so as to provide the desired ventilation, as will be described in more detail below.

[0061] The outer covering layer **54** preferably encircles, at least once, the whole length of the inner covering layer **53** and the whole length of the mouth-end filter part **52**. Hence the outer covering layer **54** preferably extends to the mouth end of the filter **52**. However, the outer covering layer **54** may extend further or less than this. The outer covering layer **54** is preferably formed from a sheet material, which is preferably a tipping paper. However, the outer covering layer **54** may be formed from any suitable material, such as a plastics material, a metal foil or a metallized paper. The outer covering layer **54** is preferably substantially non-porous.

[0062] The outer covering layer **54**, in combination with the inner covering layer **53**, defines the one or more channels **55**. The outer covering layer **54** preferably forms a substantially smooth cylindrical tube around the inner covering layer **53** and the length of the filter **52** not encircled by the inner covering layer **53**. In particular, the outer covering layer **54** preferably forms a substantially smooth cylindrical tube enveloping the ridges **59** (or other protrusions) in the irregular portion **53a** of the inner covering layer. Thus, channels **55a₁**, **55a₂**, . . . , **55a_n**, are formed in the spaces between the inner and the outer covering layers **53**, **54**, in the grooves **58** in the irregular portion **53a** of the inner covering layer. An annular space **55b** is also formed between the inner and the outer covering layers **53**, **54** where the outer covering layer **54** extends over the regular portion **53b** of the inner covering layer **53**. The outer covering layer **54** also fits closely around the mouth-end filter part **52a**. The outer diameter of the mouth-end filter part **52a** is preferably substantially the same as the diameter of the cylinder that envelopes the irregular portion **53a** of the inner covering layer **53**. Thus, the outer covering layer **54** extends smoothly between the irregular portion **53a** of the inner covering layer **53** and the mouth-end filter part **52a**.

[0063] The extent of the channels **55a** towards the mouth end of the filter **52** is preferably determined by the extent of the irregular portion **53a** of the inner covering layer **53**, as described above. The irregular portion **53a** and hence the channels **55a** preferably end at one or more intermediate locations in the filter **52**, preferably in the vicinity of where the two filter parts **52a**, **52b** meet. The channels **55a** preferably have respective outlets **57** at their ends at the intermediate locations. Because the outer covering layer **54** fits closely around the length of the filter **52** not encircled by the inner covering layer **53**, ventilating air exiting the outlets **57** is directed into the interior of the filter **52** and, in particular, into the interior of the mouth-end filter part **52a**.

[0064] The annular space **55b** has an annular opening at its end towards the tobacco end of the filter **52**. This annular opening forms an inlet **56** for the ventilating air. The annular space **55b** is also in fluid communication with each of the channels **55a**. However, the outer covering layer **54** need not extend over the regular portion **53b** of the inner covering layer **53** and so there may be no annular space. In this case, the channels **55a** have respective inlets **56** for ventilating air which are located where the outer covering layer **54** ends.

[0065] The outer covering layer **54** is preferably secured around the inner covering layer **53** by a longitudinal seam of adhesive joining opposite edges. The outer covering layer **54** is also preferably adhered, at least in part, to the ridges **59** (or other protrusions) provided on the irregular portion **53a** of the inner covering layer **53**.

[0066] Instead of the corrugated outer surface described above, the irregular portion **53a** of the inner covering layer **53** may have any shape which, in combination with the outer covering layer **54**, forms the channel between the inner and the outer covering layers **53**, **54**. For example, the irregular portion **53a** may include isolated protrusions upon which the outer covering layer **54** lies, thereby forming air flow paths in the regions between the protrusions.

[0067] In use, when the user draws on the smoking article **50**, smoke and air is drawn through the tobacco rod **51** and then the filter **52**, and ventilating air is drawn through the channels **55** and then a length of the filter **52**.

[0068] The properties of the channels 55 are preferably selected so as to provide the desired ventilation. In particular, the draw resistance of the channels 55 is determined by, amongst other things, their number, cross-sectional area, length and shape. This resistance and hence the pressure drop is preferably chosen to provide the desired ventilation. The locations of the outlets 57 of the channels 55a, i.e., the distance from either end of the filter 52, can also be selected to provide desired characteristics for the filter 52, e.g. filtering and dilution characteristics.

[0069] The smoking article 50 can have the advantage that the inlets 56 for ventilating air are much less likely to be occluded by the user's fingers as described above in relation to the first embodiment.

[0070] FIG. 7 shows a sheet 70 for forming the inner covering layer 53 of the smoking article 50. The sheet 70 is preferably formed from a standard tipping paper, as described above. The sheet 70 is preferably rectangular and is divided into two rectangular portions, namely an irregular portion 70a and a regular portion 70b. The irregular portion 70a corresponds to the irregular portion 53a of the inner covering layer 53. The regular portion 70b corresponds to the regular portion 53b of the inner covering layer 53.

[0071] The irregular portion 70a has a profile as described above in relation to the irregular portion 53a of the inner covering layer. The profile preferably has a plurality of raised pointed ridges 71, as described above. The raised pointed ridges 71 preferably each have an oblique, triangular side wall 72 at their ends nearest to the regular portion 70b of the sheet 70. However, the sidewall 72 may be substantially perpendicular to the regular portion 70b of the sheet 70 and/or may have a different shape.

[0072] The profile of the irregular portion 70a of the sheet is preferably formed by embossing. The embossing is preferably carried out using methods which will be known per se to persons skilled in the art. However, the profile may be formed using a method other than embossing. For example, if the sheet 70 is formed from a plastics material, then this may be moulded to form the profile. The whole thickness of the sheet 70 is preferably formed into the corrugations or irregularities 71. Hence the top and bottom surfaces of the sheet 70 will both have a similar, irregular profile. This is particularly suitable where the sheet 70 is formed from a tipping paper. However, the corrugations or irregularities may be formed only towards the top surface of the sheet 70, and the bottom surface of the sheet 70 may be substantially smooth. This is particularly suitable where the sheet 70 is formed from a relatively thick material.

[0073] The smoking article 50 can be manufactured using a method in which the tobacco rod 51 is joined to the tobacco-end filter part 52b by means of the inner covering layer 53, which is preferably adhered to and/or secured around the tobacco-end filter part 52b and the tobacco rod 51, as described above. The sheet 70 for forming the inner covering layer 53 is preferably embossed (or otherwise shaped) prior to being wrapped around the filter 52 and the tobacco rod 51. The mouth-end filter part 52a is then joined to the tobacco-end filter part 52b and tobacco rod 51 by means of the outer covering layer 54, which is preferably wrapped around and adhered to and/or secured around the tobacco-end filter part 52a and the inner covering layer 53.

[0074] The smoking article 50 can be manufactured using a method in which two tobacco rods 51 are simultaneously joined to each end of a double length of the tobacco-end filter

part 52b. A double length of the sheet 70 for forming the inner covering layer 53 is preferably used. The sheet preferably has the regular portion 70b at either end and an intermediate double length of the irregular portion 70a. The resulting article is then cut into two halves. The tobacco-end filter part 52 may be joined to each half as described above. Alternatively, the two halves may be simultaneously joined to each end of a double length of the tobacco-end filter part 52a. A double length of a sheet for forming the outer covering layer 54 is preferably used. The resulting article is then cut into two halves to form two smoking articles 50.

[0075] The smoking article 50 can be manufactured efficiently because its formation preferably largely consists of wrapping layers of sheet material around the two filter parts 52a, 52b and the tobacco rod 51 and because the wrapping processes themselves can be carried out efficiently. Furthermore, the smoking article 50 can be manufactured using methods and apparatuses which are based upon existing methods and apparatuses. The apparatus may include first and second tipping sections for providing the inner and outer covering layers 53, 54 respectively. The two filter parts 52a, 52b and the separate wrapping thereof can allow the sheet 70 for forming the inner covering layer 53 to be positioned more easily and can also enable a double length of the sheet 70 to be used in the 'two-up' manufacturing method described above.

Further Embodiments

[0076] It should be realised that the hereinbefore described example embodiments should not be construed as limiting. Other variations and modifications will be apparent to persons skilled in the art upon reading the present application.

[0077] The regular portion 13b, 53b of the inner covering layer 13, 53 may only encircle a length of the tobacco rod 11, 51, rather than lengths of the filter 12, 52 and the tobacco rod 11, 51. The regular portion 13b, 53b is preferably adhered to and secured around the length of the tobacco rod 11, 51. This can still help to form a good seal against air ingress between the inner covering layer 13, 53 and the tobacco rod 11, 51. In this case, the irregular portion 13a, 53a of the inner covering layer 13, 53 is preferably adhered to the filter 12, 52 to join the filter 12, 52 to the tobacco rod 11, 51.

[0078] The inner covering layer 13, 53 need not include the regular portion 13b, 53b and so may consist of only the irregular portion 13a, 53a. In this case, the irregular portion 13a, 53a preferably joins together, and forms a seal between, the filter 12, 52 and the tobacco rod 11, 51. If the inner surface of the irregular portion 13a, 53a is smooth, then a good seal can be achieved by adhering and/or securing as described above in relation to the regular portion 13b, 53b. If the inner surface of the irregular portion 13a, 53a is not smooth, e.g. because the inner covering layer 13, 53 is formed from an embossed tipping paper, then further modifications may be needed to help to achieve a good seal. For example, a relatively thick layer of adhesive may be provided between the inner covering layer 13, 53 and the tobacco rod 11, 51 for bridging the spaces therebetween.

[0079] Instead of the smooth cylindrical shape described above, the filter 12, 52 may have a different shape.

[0080] For example, the outer surface of the filter 12, 52 may be provided with corrugations or irregularities to complement those provided on the inner surface of the irregular portion 13a, 53a of the inner covering layer 13, 53. Hence the filter 12, 52 substantially fills the volume inside the inner covering layer 13, 53. This can help to avoid there being any

smoke paths through the smoking article **10, 50** which do not pass through the filtration material.

[0081] Furthermore, in relation to the second embodiment only, the filter **52** may not be divided into the two filter parts **52a, 52b**. In this case, the filter **52** preferably has a length with an increased diameter at its mouth end. The length preferably starts where the irregular portion **53a** of inner covering layer **53** ends. The increased diameter is preferably substantially the same as the diameter of the cylinder that envelopes the irregular portion **53a** of the inner covering layer **53**. However, the filter **52** may have a uniform outer diameter instead. In this case, the outer covering layer **54** may be provided with a length with an increased thickness at its mouth end. Thus, the outer covering layer **54** can be wrapped around the inner covering layer **53** and the filter **52** with less mechanical stress in the filter **52** and the layers **53, 54**.

[0082] Instead of being substantially non-porous, the inner and/or the outer covering layers **13, 14, 53, 54** may be porous. For example, they may be formed of a porous material and/or they may be provided with ventilation holes. Thus, in addition to the flow along the whole length of the channels **15, 55**, ventilating air may also be able to enter the channels **15, 55** through the outer covering layer **14, 54** and/or exit the channels through the inner covering layer **13, 53** into the filter **12, 52**. The porosity of the inner and/or the outer covering layers **13, 14, 53, 54** can be selected to provide a smoking article **10, 50** having desired ventilation characteristics.

[0083] The inner covering layer **13, 53** need not encircle the tobacco rod **11, 51** and need not be for joining the filter **12, 52** to the tobacco rod **11, 51**. Instead, a further covering layer may be used to join the filter **12, 52** to the tobacco rod **11, 51**. For example, a further covering layer may be adhered to and/or secured around a length of the regular portion **13b, 53b** of inner wrapping layer **13, 53** and a length of the tobacco rod **11, 51**. Thus, in this case, the filter **12, 52** may be wrapped with the inner and the outer covering layers **13, 14, 53, 54** independently of the formation of the smoking article **10, 50**.

[0084] Instead of being a substantially smooth cylindrical tube, the outer covering layer **14, 54** may have a different shape.

[0085] For example, the outer covering layer **14, 54** may be provided with corrugations or other irregularities on its inner surface. These corrugations or irregularities may be provided instead of those in the inner covering layer **13, 53** so as to define the channels **15, 55**. In this case, the inner covering layer **13, 53** need not be provided with an irregular portion **13a, 53a**. Alternatively, the corrugations or irregularities in the outer covering layer **14, 54** may be adapted to co-operate with those in the inner covering layer **13, 53** so as to define the channels **15, 55**. For example, the inner and the outer covering layers **13, 14, 53, 54** may have a plurality of aligned grooves and ridges.

[0086] Furthermore, the outer covering layer **14, 54** may be provided with corrugations or other irregularities on its inner surface in the region where it encircles the regular portion **13a, 53a** of the inner covering layer **13, 53**. This can help to maintain the space between the inner and the outer covering layers **13, 14, 53, 54** in this region and so ensure that the flow of ventilating air into the channels **15a, 55a** is less likely to be blocked, e.g. by deformation of the outer covering layer **14, 54** during use.

[0087] Embodiments of the invention are configured to comply with applicable laws and/or regulations, such as, by

way of non-limiting example, regulations relating to flavours, additives, emissions, constituents, and/or the like.

[0088] Any of the features described in any embodiment may be used in combination with any other features of any other embodiment.

1. A smoking article comprising a source of smokable material, a filter, a first layer surrounding at least a part of the filter, a second layer surrounding at least a part of the first layer, and at least one path for ventilating air flow between the first and second layers, wherein a part of the first layer surrounds the source of smokable material and attaches the filter thereto.

2. A smoking article comprising a source of smokable material, a filter, a first layer surrounding at least a part of the filter, a second layer surrounding at least a part of the first layer, and at least one path for ventilating air flow between the first and second layers, wherein at least a part of the at least one path is located further from an axis of the smoking article than any part of the filter or of the source of smokable material.

3. The smoking article according to claim **1**, wherein at least a part of the first layer comprises an irregular outer surface that defines, together with the second layer, the at least one path.

4. The smoking article according to claim **3**, wherein the irregular outer surface comprises a plurality of elongate ridges extending generally along the filter, the at least one path being at least partially located between adjacent ridges.

5. The smoking article according to claim **1**, wherein the first layer comprises a part with a smooth inner surface that surrounds a part of the source of smokable material or surrounds adjacent parts of the source of smokable material and of the filter.

6. The smoking article according to claim **1**, wherein the at least one path has at least one air inlet that is located one of near to and beyond an end of the filter nearest to the source of smokable material, the at least one air inlet defined by extents of the first and the second layers one of towards and beyond the end of the filter.

7. The smoking article according to claim **1**, wherein the at least one path has at least one air outlet located near to an end of the filter furthest from the source of smokable material, the at least one air outlet defined by extents of the first and the second layers one of towards and beyond the end of the filter.

8. The smoking article according to claim **1**, wherein the at least one path has at least one air outlet into the filter, the at least one air outlet into the filter defined by an extent of the first covering layer towards an end of the filter furthest from the source of smokable material, and wherein the second layer extends one of to and near to the end of the filter.

9. The smoking article according to claim **8**, wherein the filter is longitudinally divided into first and second filter parts, the first layer extending one of to and near to the end of the first filter part furthest from the source of smokable material, and wherein the second layer extends one of to and near to the end of the second filter part furthest from the source of smokable material.

10. The smoking article according to claim **1**, wherein at least one of the first layer and the second layer is formed from a sheet material.

11. A method of manufacturing a smoking article, the method comprising providing a source of smokable material, providing a filter, surrounding at least a part of the filter with a first layer, surrounding at least a part of the first layer with a

second layer, and forming at least one path for ventilating air flow between the first and second layers, wherein a part of the first layer surrounds the source of smokable material and is configured to attach the filter thereto, or wherein at least a part of the one or more paths is located further from an axis of the smoking article than any part of the filter or of the source of smokable material.

12. The method according to claim **11**, further comprising forming an irregular outer surface on at least a part of the first layer, the irregular outer surface defining, together with the second layer, the at least one path.

13. The method according to claim **12**, wherein the first layer is formed from a sheet material, and wherein forming the irregular outer surface comprises embossing the sheet material.

14. The method according to claim **11**, comprising providing a first filter part, surrounding at least a part of the first filter part with the first layer, providing a second filter part adjacent to the first filter part, and surrounding at least a part of the first layer and at least a part of the second filter part with the second layer.

15. (canceled)

16. The smoking article according to claim **2**, wherein at least a part of the first layer comprises an irregular outer surface that defines, together with the second layer, the at least one path.

17. The smoking article according to claim **16**, wherein the irregular outer surface comprises a plurality of elongate ridges extending generally along the filter, the at least one path being at least partially located between adjacent ridges.

18. The smoking article according to claim **2**, wherein the first layer comprises a part with a smooth inner surface that

surrounds a part of the source of smokable material or surrounds adjacent parts of the source of smokable material and of the filter.

19. The smoking article according to claim **2**, wherein the at least one path has at least one air inlet that is located one of near to and beyond an end of the filter nearest to the source of smokable material, the at least one air inlet defined by extents of the first and the second layers one of towards and beyond the end of the filter.

20. The smoking article according to claim **2**, wherein the at least one path has at least one air outlet located near to an end of the filter furthest from the source of smokable material, the at least one air outlet defined by extents of the first and the second layers one of towards and beyond the end of the filter.

21. The smoking article according to claim **2**, wherein the at least one path has at least one air outlet into the filter, the at least one air outlet into the filter defined by an extent of the first covering layer towards an end of the filter furthest from the source of smokable material, and wherein the second layer extends one of to and near to the end of the filter.

22. The smoking article according to claim **21**, wherein the filter is longitudinally divided into first and second filter parts, the first layer extending one of to and near to the end of the first filter part furthest from the source of smokable material, and wherein the second layer extends one of to and near to the end of the second filter part furthest from the source of smokable material.

23. The smoking article according to claim **2**, wherein at least one of the first layer and the second layer is formed from a sheet material.

* * * * *