

Dec. 11, 1951

L. AHMANSON

2,578,029

TOY PISTOL

Filed Feb. 8, 1951

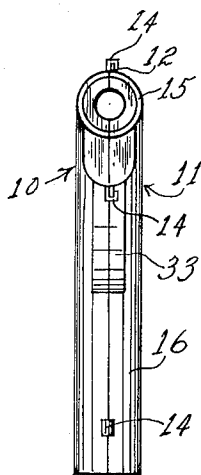
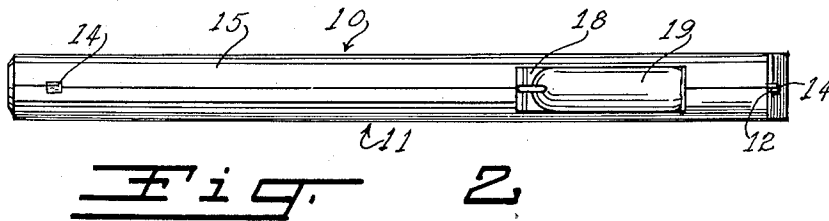
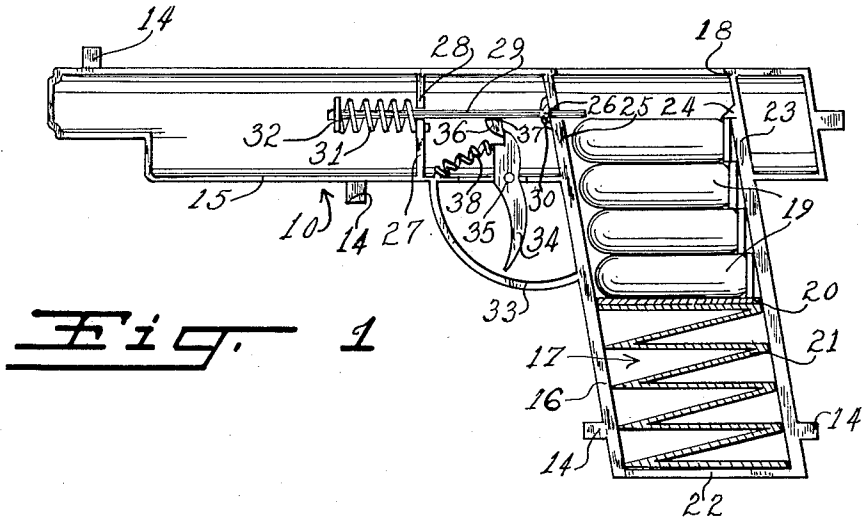

INVENTOR.  
Leonard Ahmanson  
BY  
Sherman Levy  
ATTORNEY

# UNITED STATES PATENT OFFICE

2,578,029

## TOY PISTOL

Leonard Ahmanson, Washington, D. C.

Application February 8, 1951, Serial No. 210,042

1 Claim. (Cl. 124-16)

1

2

This invention relates to a toy, and more particularly to a toy pistol.

The object of this invention is to provide a toy pistol which has a realistic appearance, and wherein dummy cartridges will be automatically ejected from the toy to simulate the firing or operation of a pistol.

Another object of the invention is to provide a toy pistol which can be manually actuated to cause a plurality of dummy cartridges to be ejected one at a time, the toy pistol of the present invention being adapted to receive and hold a plurality of the cartridges when the toy pistol is to be loaded, whereby a child or other person will be provided with a safe source of recreation or amusement.

A further object of the invention is to provide a toy pistol which is extremely simple and inexpensive to manufacture.

Other objects and advantages will be apparent during the course of the following description.

In the accompanying drawings forming a part of this application, and in which like numerals are used to designate like parts throughout the same:

Figure 1 is a longitudinal sectional view taken through the toy pistol constructed according to the present invention;

Figure 2 is a top plan view of the toy pistol constructed according to the present invention;

Figure 3 is a front elevational view of the toy pistol.

Referring in detail to the drawings, there is shown a toy pistol which may be fabricated of any suitable material such as metal or plastic. The toy pistol of the present invention includes a pair of similar sections 10 and 11. For maintaining these sections 10 and 11 connected together, suitable ears 12 project from the section 11, or are formed integrally therewith, and clips 14 extend from the other section 10. The clips 14 are adapted to be bent over the ears 12, whereby the parts will be maintained connected together. The toy pistol further includes a forwardly extending barrel 15 and a handle portion 16 which is adapted to be conveniently gripped in the user's hand. The handle portion 16 is hollow so as to provide a cartridge chamber 17 for a purpose to be later described. The pistol is further provided with an opening 18 through which the ejected cartridges are adapted to be discharged.

Arranged in the chamber or compartment 17 is a plurality of dummy cartridges 19 which may be fabricated of any suitable material. A plate

20 is slidably arranged in the chamber 17, and a spring member 21 is interposed between the plate 20 and the bottom wall 22. Thus, the spring member 21 normally urges the cartridges 19 and the plate 20 upwardly in the chamber 17.

The toy pistol further includes an inclined extension 23 which has a pointed tooth 24 projecting therefrom, Figure 1. Thus, as the dummy cartridges 19 move upwardly in the chamber 17, the rear ends of these cartridges will engage the tooth 24 so that the cartridges will be ejected and discharged rearwardly through the opening 18.

Arranged forwardly of the extension 23 is a wall member 25, and the wall member 25 is provided with an opening 26. Arranged in front of the wall member 25 and positioned in the barrel 15 is a partition 27 being provided with an opening 28 which is arranged in alignment with the opening 26. A rod 29 is slidably arranged in the barrel 15, and the rod 29 slidably projects through the openings 28 and 26. Formed integrally with the rod 29 or secured thereto is a shoulder 30, and the shoulder 30 is adapted to abut the extension 25 to limit rearward movement of the rod 29. A coil spring 31 is circumposed on the front end of the rod 29, and the coil spring 31 has one end connected to the partition 27, while the front end of the coil spring 31 is connected to a washer 32 which is arranged on the tip of the rod 29.

Extending between the bottom of the barrel 15 and the handle 16 is an arcuate trigger bar 33. A movable trigger 34 is pivotally connected to the barrel 15 by a pin 35, and the upper end of the trigger 34 is adapted to selectively engage a lug 36. The lug 36 is pivotally connected to the bottom of a rod 39 by means of a pivot pin 37. Extending between the barrel 15 and the trigger 34 and secured thereto is a coil spring 38.

In use, to load the toy pistol, the back end of the dummy-cartridge or shell 19 is inserted through the opening 18 so that it slips under the tooth or lip 24. The front end of the cartridge 19 is pushed down against the trigger pin or rod 29 with one hand, and then the trigger 34 is actuated or pivoted in a counterclockwise direction forcing the rod 29 forwardly and allowing the cartridge 19 to come down in place beneath the rear end of the rod 29, after it returns to its normal position. This is repeated until the chamber 17 is loaded with a plurality of the cartridges 19. Then, in operation, the trigger 34 is actuated to push the rod 29 forwardly so that the spring member 21 will cause one of the cartridges 19 to be ejected in a tumbling manner

3

to simulate the firing of a real gun, because of the tooth 24. As the trigger 34 is actuated, the rod 29 travels forwardly far enough to clear the nose of the cartridge 19 and then the top of the trigger 34 clears the lug 36. Then the rod 29 is snapped back into position because of the spring 31 so that only one cartridge 19 can be discharged at a time. Upon releasing the trigger, the lug 36 pivots so that the spring 38 will cause the trigger 34 to return to its normal position. Thus, there has been provided a toy pistol which is constructed so that dummy cartridges will be automatically ejected from the toy upon actuation thereof, to thereby simulate the firing of a real pistol.

What is claimed is:

A toy pistol comprising a pair of sections connected together to define a hollow handle having a cartridge chamber therein, a barrel projecting forwardly from said handle and connected thereto, an arcuate trigger guard connected to said barrel and handle, a plurality of cartridges arranged in superimposed relation in said chamber, a plate movably mounted in said chamber and engaging the lowermost of said cartridges, a spring member for normally urging said plate upwardly in said chamber, a pointed tooth secured in said chamber adjacent the upper end thereof for engaging the rear ends of said cartridges, there being an opening on the top side

4

of the pistol for the discharge therethrough of the ejected cartridges, there being a wall arranged rearwardly in said barrel and provided with an opening, a partition arranged in spaced relation forwardly of said wall and provided with an opening for registering with the opening in said wall, a rod slidably disposed in said openings and having the rear end thereof normally disposed in said chamber and above the cartridges for retaining said cartridges in said superimposed relation, said rod having a shoulder to abut against said wall to limit the rear movement of said rod, a coil spring circumposed on said rod and connected to the forward end thereof and to said partition for urging said rod to said normally disposed position, a lug pivotally connected to the bottom of said rod, a trigger pivotally connected to said barrel and having its upper end engaging said lug, and a coil spring having one end connected to said barrel and its other end connected to the upper front portion of said trigger.

LEONARD AHMANSON.

#### REFERENCES CITED

The following reference is of record in the file of this patent:

#### UNITED STATES PATENTS

Number	Name	Date
2,527,254	Hjelm	Oct. 24, 1950