

Aug. 5, 1969

F. J. HAGEMANN

3,459,022

ROLLER-EQUIPPED STRAIGHTENING MACHINE

Filed Dec. 22, 1966

2 Sheets-Sheet 1

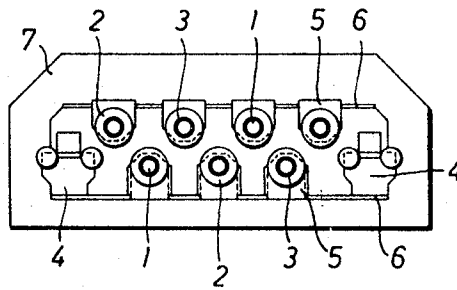

Fig. 1 *PRIOR ART*

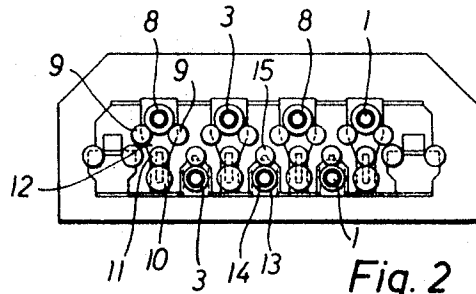

Fig. 2

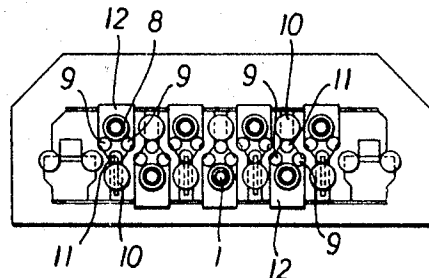

Fig. 3

Aug. 5, 1969

F. J. HAGEMANN

3,459,022

ROLLER-EQUIPPED STRAIGHTENING MACHINE

Filed Dec. 22, 1966

2 Sheets-Sheet 2

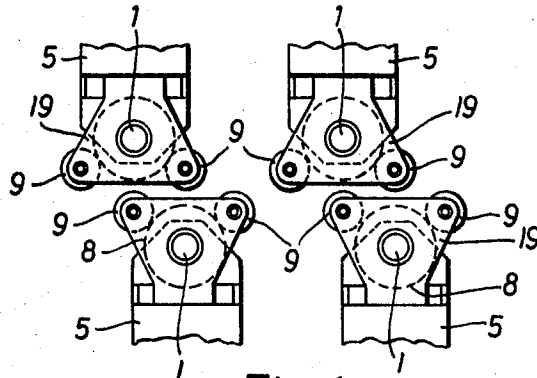

Fig. 4

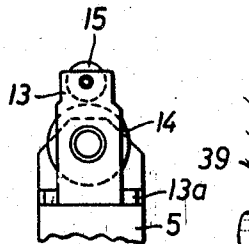

Fig. 5

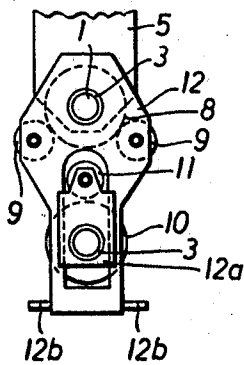

Fig. 6

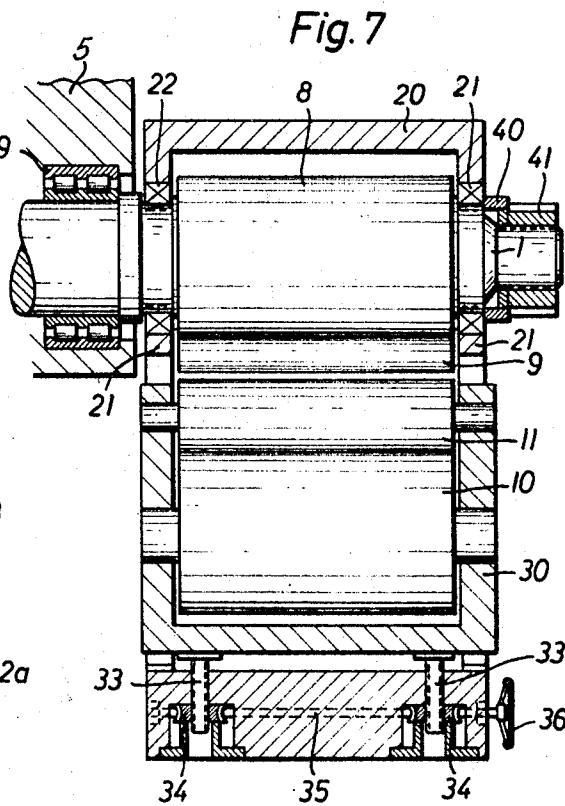

Fig. 7

1

3,459,022

ROLLER-EQUIPPED STRAIGHTENING MACHINE
 Franz Josef Hagemann, Erkelenz, Rhineland, Germany,
 assignor to Maschinen- und Bohrgerate-Fabrik Alfred
 Wirth & Co., Erkelenz, Rhineland, Germany, a company
 of Germany

Filed Dec. 22, 1966, Ser. No. 604,004

Claims priority, application Germany, Dec. 29, 1965,
 M 67,836

Int. Cl. B21d 1/02

U.S. Cl. 72-163

4 Claims

ABSTRACT OF THE DISCLOSURE

A machine for straightening material in which straightening axle journals are arranged in staggered relationship to each other in an overhung fashion and with each axle having a free end adapted to receive an exchangeable straightening roller thereby allowing an alteration of the roller distribution. Moreover, additional work rollers are capable of being carried by the free ends of the axle journals with such rollers being the original straightening rollers or support rollers exchanged therefor.

Background of the invention

The invention relates to a roller equipped straightening machine having straightening axle journals or the like arranged in staggered relationship to each other, with each of the journals receiving an exchangeable straightening roller, thereby affording the possibility of altering the roller distribution.

In rolling mill technique there are today numerous situations in which machines constructed in the known manner can no longer effectively accomplish the desired results because the material to be straightened is too different, with respect to its characteristics and dimensions. Recent devices permit a very wide program to be undertaken. For example, on a modern rolling-mill path, in what are called wide-flanged beam rolling mills, not only can beams of differing dimensions be rolled, but it is also possible to produce periodically on such paths flat billets or sheets.

For straightening the products associated with a wide-flanged beam program, for instance for beam dimensions of HEB ("Euro-Norm" designation for a wide-flanged beam of I profile) 100 to 400, a roller straightening machine with alterable or changeable roller spacing in the region of 1300 to 1800 mm. is necessary. With flat billets and the like, on the other hand, the straightening can be carried out with a greater number of straightening rollers only, which have a smaller roller spacing from each other, for instance 500 mm.

Known straightening machine offer no possibility of handling such widely contrasting products. Accordingly, for the adjustment of the machines, in addition to the suitable transport devices, at least one roller straightening machine for straightening section steel and a further straightening machine for straightening flat billets, sheets or the like, are necessary. In addition, for the last-men-

2

tioned products, a separate squaring shearer is required.

If, as is usually the case, in addition there is only one work line, the sheet straightening machine and the section steel straightening machine must be arranged so that they can travel opposite each other on rails transverse to the work direction, in order that they can be introduced selectively in the work line, and either section steel or billet steel or sheets can be straightened.

Summary of the invention

The problem of the invention is to overcome the difficulties existing in the above and similar situations, and to fulfill, with less expenditure on machines and less space requirement than was previously the case, the requirements arising from different work programs.

The solution of the invention comprises in equipping a straightening machine selectively with additional rollers, in order in this way, by altering the number and distribution of the rollers, to adapt the machine to the requirements of the situation at hand. Such additional work rollers can bear on the rollers resting on the straightening axle journals, with the second rollers mentioned being the original straightening rollers or support rollers in place thereof.

In this way compensation can be made for the most varied requirements as regards the material to be straightened. Only a single machine is required, which for instance can be used in the first place for the straightening of the section steel or the like, and in which connection, depending of the size of the section, comparatively great straightening axle spacings with a low number of rollers are necessary. In the second place, the machine, without particular difficulty, can be changed over for other conditioning factors, in order to handle products which require a greater number of rollers with a closer roller distribution. Considerable investment and working cost reductions result as compared with the previous conditions.

There are many possible variations with reference to the arrangement of the rollers. The machine can easily be adapted to the requirements as they arise and there can even be an arrangement in which both the upper and the lower rollers are associated in each situation with two work rollers.

The invention furthermore provides that each group of work rollers associated with a straightening axle journal has related thereto one or a plurality of counter-work rollers abutting on a support roller lying opposite the straightening axle journal. In this connection, the arrangement can be such that the support rollers for a part of the counter-work rollers are rollers resting on straightening axle journals, while for another part of the counter-work rollers, special support rollers are provided between the straightening axle journals.

In accordance with a further feature of the invention, the work rollers or counter-work rollers are at least in part pivotable about the axis of the associated support roller thus affording a further possibility for adjustment and adaptation.

There are fundamentally varying possibilities for the bearing or holding of the rollers. In an advantageous embodiment the invention provides a roller carrier which can in each situation be pushed on a straightening axle

journal, and in which carrier one or a plurality of the additional rollers are disposed. In a roller carrier of this type, as well as the work rollers associated with the straightening axle journal concerned, and in accordance with the desired roller arrangement, one or a plurality of counter-work rollers can also be arranged with the associated support rollers. One or a plurality of counter-work rollers can, in this connection, be arranged displaceably in the roller carrier together with the support roller. The roller carrier per se constitutes a frame which can take traction forces and the forces developing in the straightening process then occur reciprocally, and accordingly do not stress the straightening axle journal per se so as to cause such journal to bend.

By means of such roller carriers capable of being pushed on the straightening axle journal, the machine can be quickly and simply changed over from one method of operation to another.

Over and above the situations above expressly mentioned, the invention can be used for the whole sphere of section steel production, and in the production of rod steel and special profiling. The invention offers the possibility of obtaining the straightening range in each situation leading to an optimum straightening effect with a suitable distribution and number of rollers for the most varied requirements. The invention can find use both with straightening machines provided with fixed straightening axles as well as machines in which the spacing of the straightening axles can be altered.

Brief description of the drawings

The invention will now be described with reference to the accompanying drawings, which show various embodiments of the invention but in no restrictive sense.

FIGURE 1 is an elevational view of a roller straightening machine of customary construction (prior art).

FIGURE 2 is an elevational view of a roller straightening machine constructed in accordance with the invention;

FIGURE 3 is an elevational view of a further embodiment of a roller straightening machine of the invention;

FIGURE 4 is a fragmentary view in elevation of a possible construction and arrangement of roller carriers;

FIGURE 5 is a fragmentary view in elevation of another embodiment of a roller carrier;

FIGURE 6 is a fragmentary view in elevation of a further embodiment of a roller carrier; and

FIGURE 7 is a perpendicular central section through a roller carrier of the type shown in FIGURE 6.

Detailed description of the invention

FIGURE 1 discloses a roller straightening machine for straightening rod and section steel, with straightening being arranged in staggered relationship, and with seven main straightening rollers. The main straightening axles are carried in housings 5 and end in overhung straightening axle journals 1, on which straightening rollers 2 rest, braced by means of a bayonet type closure 3, with the straightening rollers being for instance section steel rollers for straightening wide-flanged beams. Between the rollers 6 and the driven straightening axle journals is provided an adjusting spring connection, for the rotating entrainment of the rollers. The housing 5 together with the straightening axles is displaceable inside machine supports 7 on slide ways 6, so that the roller distribution can be altered within certain limits. The smallest spacing of the rollers from each other amounts, for instance, to 1300 mm. The lower housings 5 can be equipped with means for vertically adjusting the straightening axles. Run-in and run-out blocks 4 are used for supplying and removing the material to be straightened.

In order to make such a machine usable for other straightening tasks, such as for straightening sheets, it is equipped, in accordance with the invention, with additional work rollers.

In the embodiment of FIGURE 2 each roller located on the upper straightening axle journals is associated with two work rollers 9 resting thereon. If the original straightening rollers 2 (FIGURE 1) are suitable for forming the support by reason of their shape, they can remain in place; otherwise they are exchanged for cylindrical support rollers 8, as is shown in FIGURE 2.

Midway under each pair of work rollers 9 there is arranged a work roller 11 running against a cylindrical support roller 10. In between and in each case there are provided further work rollers 15 which run on support rollers 14. The support rollers 14 rest on the three lower straightening axle journals 1. The lower straightening axles with the rollers 14, 15 are vertically adjustable like the rollers 10, 11 for applying the bending-through necessary for the straightening operation.

For the additional arrangement of the rollers, the invention provides in particular roller carriers of a frame-type construction, which can be pushed onto the rotatable straightening axle journals from the side as a complete unit, and are carried thereon by means of roller bearings. By this means, the machine can quickly be changed over from one to the other method of operation. Details of such a carrier which can be pushed onto the axle journals are set forth hereinafter.

FIGURE 6 illustrates in side elevation a roller carrier used in the embodiment of FIGURE 2 for receiving the rollers 8, 9 and 11. A roller carrier 12 is pushed onto an upper straightening axle journal 1 and secured with the bayonet type closure 3 and in it the work roller 11 together with the associated support roller 10 are carried thereby. The carrier also includes a part 12a that is vertically adjustable in a recess, and which part supports the work roller 11 with the associated support roller 10. As a result of the frame-type construction of the roller carrier 12, the straightening axle journal per se is required to take only the bending moment arising from the straightening. The straightening axle bearing per se is relieved, and carries only the roller carrier 12 with the rollers. Optionally for the roller carrier also a support can be provided. By means of guide strips or pressure pieces 12b, the roller carrier 12 can be fixed in the desired position. It should further be mentioned that in case of need, for instance, the work rollers 9 also can be arranged displaceably in the roller carrier.

In FIGURE 5 a roller carrier 13 is shown in which in the machine of FIGURE 2 is pushed onto a lower straightening axle journal 1, and contains the bearing for the work roller 15. Pressure pieces 13a provided on the housing 5 are used for adjusting or fixing the roller carrier 13 in the required position.

As this example shows, a roller straightening machine with, for instance, seven straightening rollers (FIGURE 1) can be changed over without difficulty into a straightening machine with fifteen straightening rollers in accordance with FIGURE 2. In this connection, the roller distribution can be reduced to for instance 450 mm. In this way, the invention makes it possible to extend the straightening range of a machine considerably, whether in relation to other profile dimensions or even for products of a different type.

A further possibility for the roller arrangement is shown in FIGURE 3. In this embodiment, with a straightening machine provided initially with seven straightening rollers, by pushing the roller carriers 12 on all seven straightening axle journals, a total number of twenty-one straightening rollers is obtained. This can be advantageous, for instance for straightening material of greater tensile strength and yield point values. Machines suitable for these purposes hitherto had to be specially manufactured with a determined number of rollers. Subsequent alteration of the machine in order to satisfy special requirements very frequently occurring, was not possible.

Finally, FIGURE 4 illustrates an embodiment in which roller carriers 19 are set onto the individual straightening axle journals, with each carrier supporting two work rollers 9, so that a doubling of the original number of straightening rollers results.

FIGURE 7 discloses roller carrier constructed as a frame of the type shown in FIGURE 6. The carrier includes a main frame 20 which can be pushed from the side onto a journal 1. In side walls 21 of the frame are arranged roller bearings 22, and a sleeve shown in dotted lines can be provided between the bearings and the journal. A roller 8 rests on the journal or on a sleeve of this type, which is entrained by the driven straightening axle as it rotates, for instance, by means of keys. Two work rollers 9 carried in the frame 20 abut on the roller 8, and only one of which can be seen in FIGURE 7.

In the lower part of the frame 20 a housing 30 is mounted for vertical displacement, and carries a lower work roller 11 together with the associated support roller 10. The bearing can be a journal bearing or a roller bearing. Adjustment of the straightening gap is effected by vertical displacement of the housing 30 by means of two spindles 33, worm wheels 34 and a worm shaft 35. The worm shaft 35 can be adjusted by means of a hand wheel 36, motor or by mechanical/hydraulic devices.

As well as other advantages, the frame-construction affords relief for an overhung main straightening axle bearing 39, because the reciprocally-directed forces which arise during the straightening operation are received by the side walls 21, and only the straightening axle piece located between the bearings 22 is subjected to bending stress.

As in FIGURE 6, a guide of the frame 20 can be constituted by displaceable guide strips, and this furthermore permits angular adjustment of the rollers associated with each other with the straightening axle journal as pivot point.

The roller carrier frame 20 is mounted by being pushed onto the straightening axle journal 1 and then secured by a bayonet closure ring 40 provided with a nut 41. The periphery of the nut 41 is formed with a plurality of spaced apart longitudinally extending grooves and the ring with a plurality of corresponding projections. Then the nut 41 is drawn up to a determined amount on the journal 1, the ring 40 can be pushed over the nut until it abuts against a portion of the frame 20 which has previously been pushed onto the straightening axle. The ring 40 can then be turned approximately 45° thereby effecting a displacement of the projections relative to the grooves of the nut thus locking the components. On dismantling the nut 41 is backed off by several turns, the ring rotated through approximately

45° and removed over the nut. It is then possible for the entire roller carrier frame to be removed over the nut 41.

It should be mentioned that it is possible, for instance, for accurate arrangement of the roller carriers in the work line, to adjust the roller carriers in the axial direction in each case in common with the associated axle, or optionally also on the same.

All the characteristics mentioned in the above description and illustrated in the drawing should, insofar as the known prior art permits, be regarded separately or in combination as important for the invention, even if they are not expressly mentioned in the claims.

I claim:

1. An auxiliary straightener to be mounted on a conventional machine for straightening material, including axle journals arranged in staggered relationship to each other in an overhung manner with respect to said machine, each axle journal having a free end, exchangeable support rollers received on the free ends, work rollers abutting said support rollers and between said support rollers and a material to be straightened and means connecting said work rollers to said journals.

2. The auxiliary straightener in accordance with claim 1, wherein said means connecting said work rollers to said journals constitutes frames spanning the lengths of said work rollers and said support rollers and means removable mounting said frames on the free ends.

3. The auxiliary straightener in accordance with claim 2, including additional work rollers and support rollers opposite the first mentioned work rollers and support rollers mounted in said frames,

4. The auxiliary straightener in accordance with claim 3, including means on said frames for adjustably positioning said additional work rollers and support rollers relative to said first mentioned work rollers and support rollers.

References Cited

UNITED STATES PATENTS

1,959,492	5/1934	Moses	72—165
2,501,087	3/1950	Picton et al.	72—164
2,592,948	4/1952	Peterson	72—160
2,720,242	10/1955	Siegerist	72—164
2,852,065	9/1958	Peterson	72—164
3,273,369	9/1966	Modder	72—164
3,309,907	3/1967	Steinhardt	72—164

MILTON S. MEHR, Primary Examiner

U.S. Cl. X.R.

72—164, 165