



US00D795202S

(12) **United States Design Patent** (10) **Patent No.:** **US D795,202 S**
Dimberg et al. (45) **Date of Patent:** **** Aug. 22, 2017**

(54) **TABLETOP REMOTE LOAD CONTROL DEVICE**

39/088; G08C 17/00; G08C 17/02; G08C 19/28; G08C 23/02; G08C 23/04
See application file for complete search history.

(71) Applicant: **Lutron Electronics Co., Inc.**,
Coopersburg, PA (US)

(56) **References Cited**

U.S. PATENT DOCUMENTS

(72) Inventors: **Chris Dimberg**, Easton, PA (US);
Elliot G. Jacoby, Glenside, PA (US);
Jason C. Killo, Emmaus, PA (US);
Brad M. Kreschollek, Bethlehem, PA
(US); **Matthew P. McDonald**,
Phoenixville, PA (US)

4,199,883 A * 4/1980 Cross A47G 1/141
40/735
D259,184 S * 5/1981 Francis D10/15
4,496,127 A * 1/1985 Nelson A47B 19/10
211/43
D278,109 S * 3/1985 Leeds D19/91
D329,609 S * 9/1992 Wolff D10/15
D348,481 S * 7/1994 Grant D19/21
D367,647 S * 3/1996 Faggard D14/387
D370,355 S * 6/1996 Kenney D6/310

(Continued)

(73) Assignee: **Lutron Electronics Co., Inc.**,
Coopersburg, PA (US)

Primary Examiner — Selina Sikder

(**) Term: **15 Years**

(74) *Attorney, Agent, or Firm* — Philip N. Smith; Mark
E. Rose; Glen R. Farbanish

(21) Appl. No.: **29/575,110**

(57) **CLAIM**

(22) Filed: **Aug. 22, 2016**

We claim the ornamental design for a tabletop remote load control device, as shown and described.

Related U.S. Application Data

DESCRIPTION

(62) Division of application No. 29/512,028, filed on Dec. 16, 2014, now Pat. No. Des. 767,508.

(51) **LOC (10) Cl.** **14-03**

(52) **U.S. Cl.**
USPC **D13/168**

(58) **Field of Classification Search**
USPC D13/164, 168; D10/104.12, 106.1;
D14/218

CPC H03J 1/0025; H03J 9/00; H03J 9/02; H03J 9/04; H03J 9/06; H01H 2009/187; H01H 9/02; H01H 9/0214; H01H 9/0242; H01H 9/18; H05B 37/02; H05B 37/0272; H05B

FIG. 1 is a perspective view of a tabletop remote load control device according to our new design.
FIG. 2 is a top view thereof.
FIG. 3 is a left side view thereof.
FIG. 4 is a right side view thereof.
FIG. 5 is a front view thereof.
FIG. 6 is a rear view thereof.
FIG. 7 is a bottom view thereof.
FIG. 8 is an alternate view thereof taken in a direction that is normal to the front surface of the angled portion of the tabletop remote load control device; and,
FIGS. 9-14 are enlarged views of the buttons of the tabletop remote load control taken in a direction that is normal to the front surface of the angled portion.

(Continued)

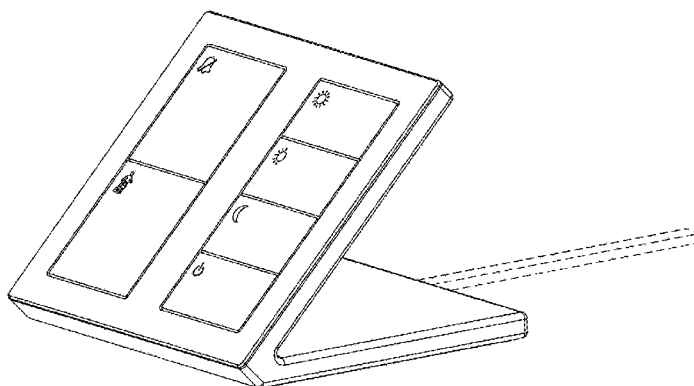

The broken lines showing portions of the tabletop remote load control device are for the purpose of illustrating environmental structure and form no part of the claimed design.

1 Claim, 10 Drawing Sheets

(56)

References Cited

U.S. PATENT DOCUMENTS

5,876,106 A 3/1999 Kordecki
 D416,284 S * 11/1999 O'Malley D19/20
 6,120,262 A 9/2000 McDonough et al.
 D440,542 S * 4/2001 Hawkins D14/346
 D496,335 S 9/2004 Spira
 D511,110 S * 11/2005 Rodela D10/40
 D537,046 S 2/2007 Blair et al.
 7,312,695 B2 12/2007 Lehmer et al.
 D559,559 S * 1/2008 Butcher D6/309
 D576,564 S 9/2008 Hewson et al.
 D626,092 S 10/2010 Clymer et al.

D627,307 S 11/2010 Petrillo et al.
 D631,855 S 2/2011 Blair et al.
 D633,874 S 3/2011 Feldstein et al.
 D636,739 S 4/2011 Petrillo et al.
 D647,066 S 10/2011 Jacoby et al.
 D649,123 S 11/2011 Jacoby et al.
 D658,594 S 5/2012 Felegy et al.
 D661,266 S * 6/2012 Laube D14/126
 D666,619 S * 9/2012 May D14/447
 D669,038 S 10/2012 Felegy, Jr. et al.
 8,469,204 B1 6/2013 Bradshaw
 D694,197 S 11/2013 Felegy, Jr. et al.
 D704,151 S 5/2014 Jacoby et al.
 D712,867 S * 9/2014 Vats D14/138 AB
 D718,724 S 12/2014 Clymer et al.
 D733,667 S 7/2015 Jacoby et al.
 D749,564 S * 2/2016 Cho D14/341
 D760,214 S * 6/2016 Kemper D14/253
 D767,508 S * 9/2016 Dimberg D13/168
 2002/0135974 A1 * 9/2002 Bell A47G 1/142
 361/679.41
 2012/0013450 A1 1/2012 Lee et al.

* cited by examiner

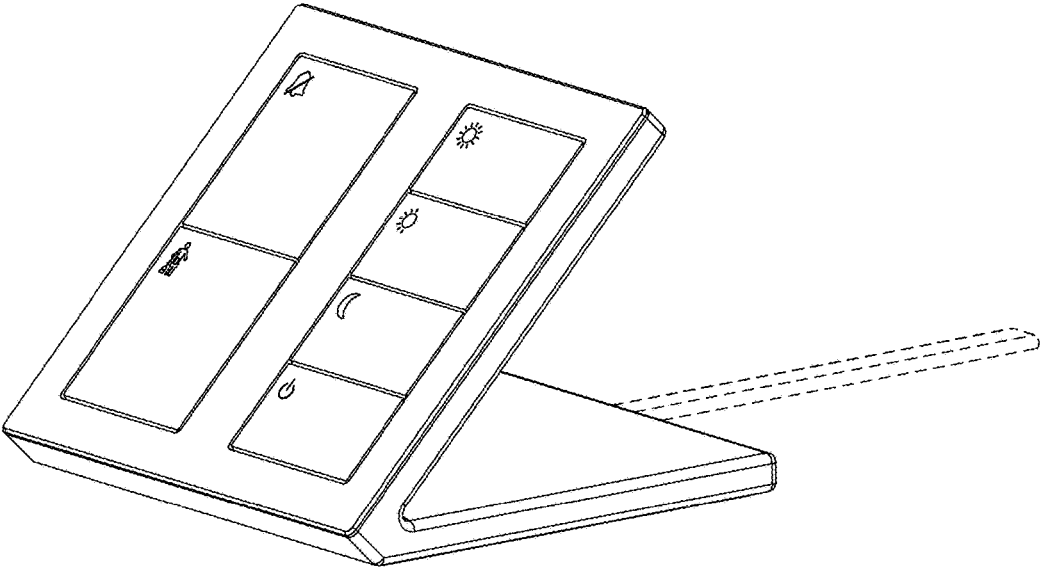

Fig. 1

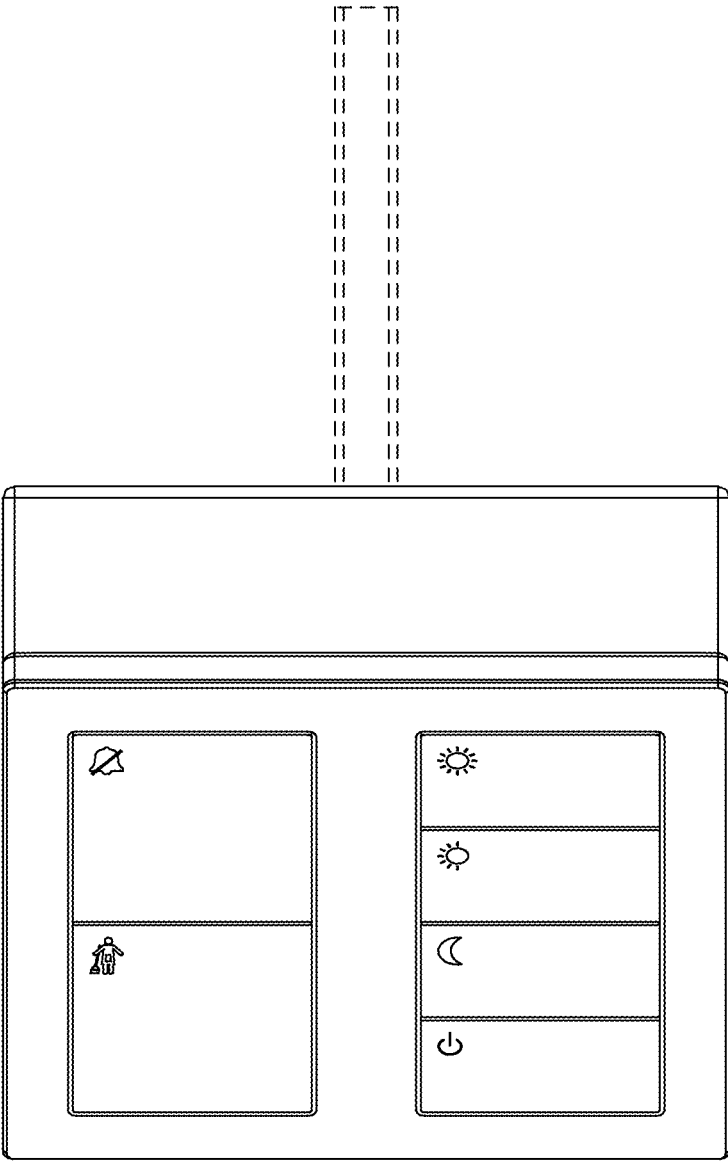

Fig. 2

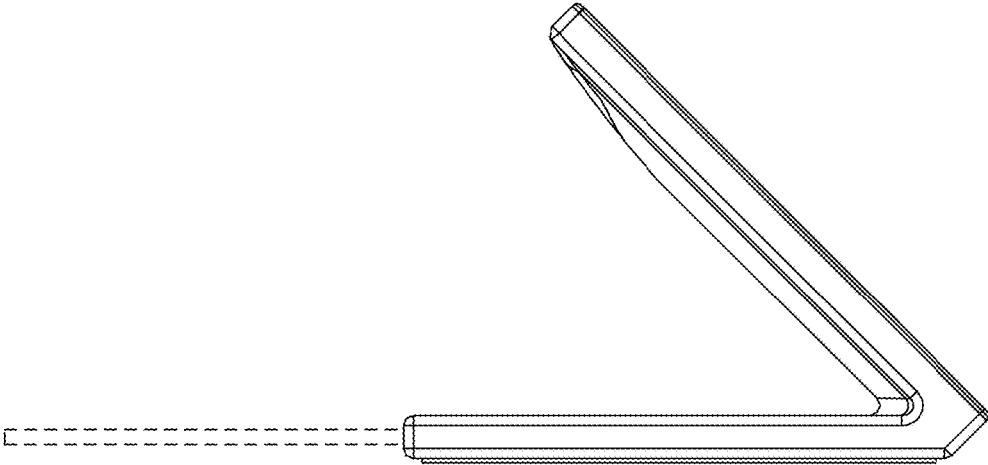

Fig. 3

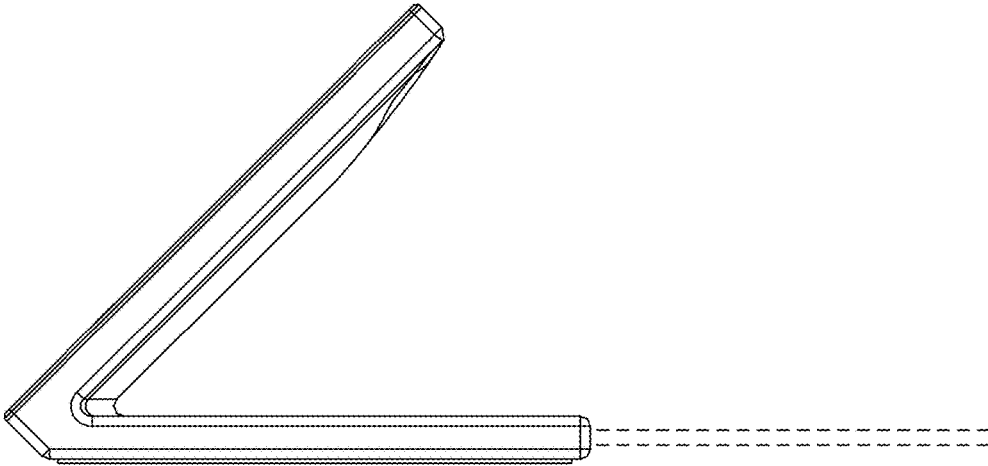

Fig. 4

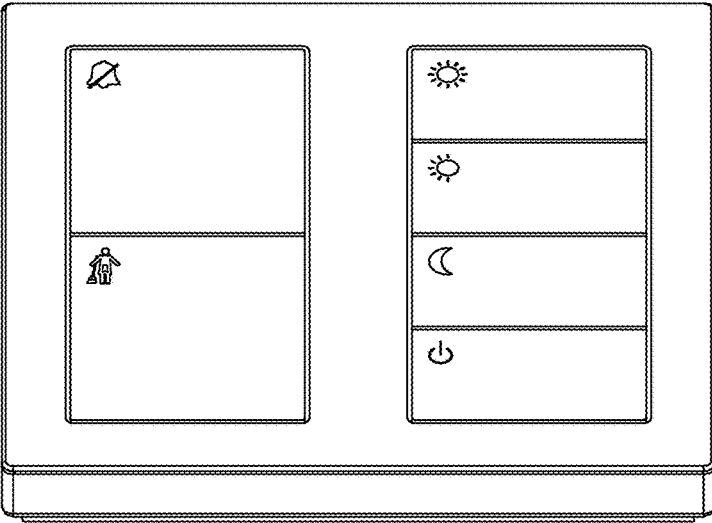

Fig. 5

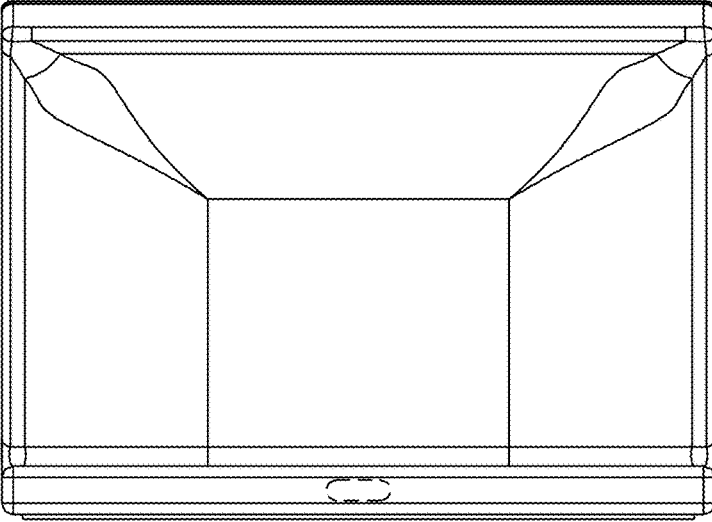

Fig. 6

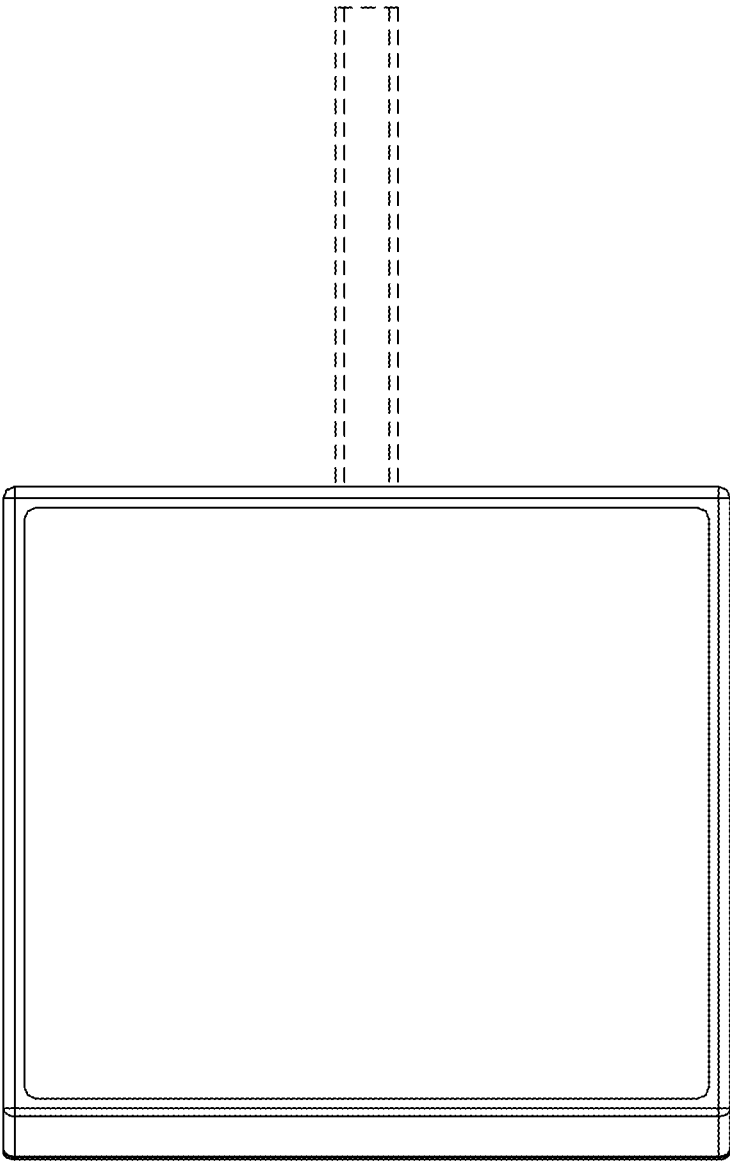

Fig. 7

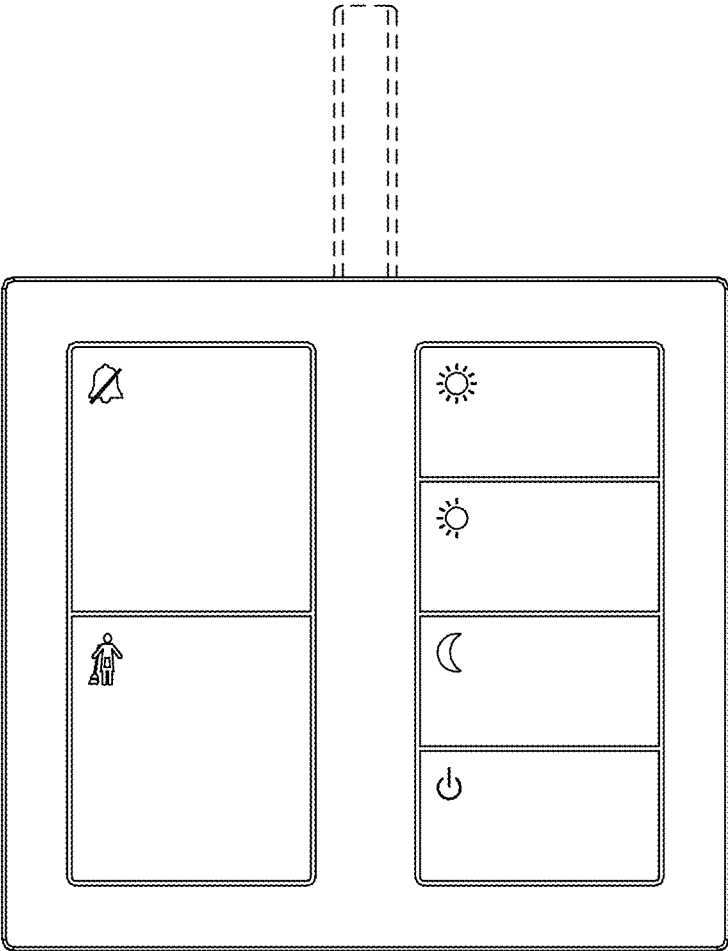

Fig. 8

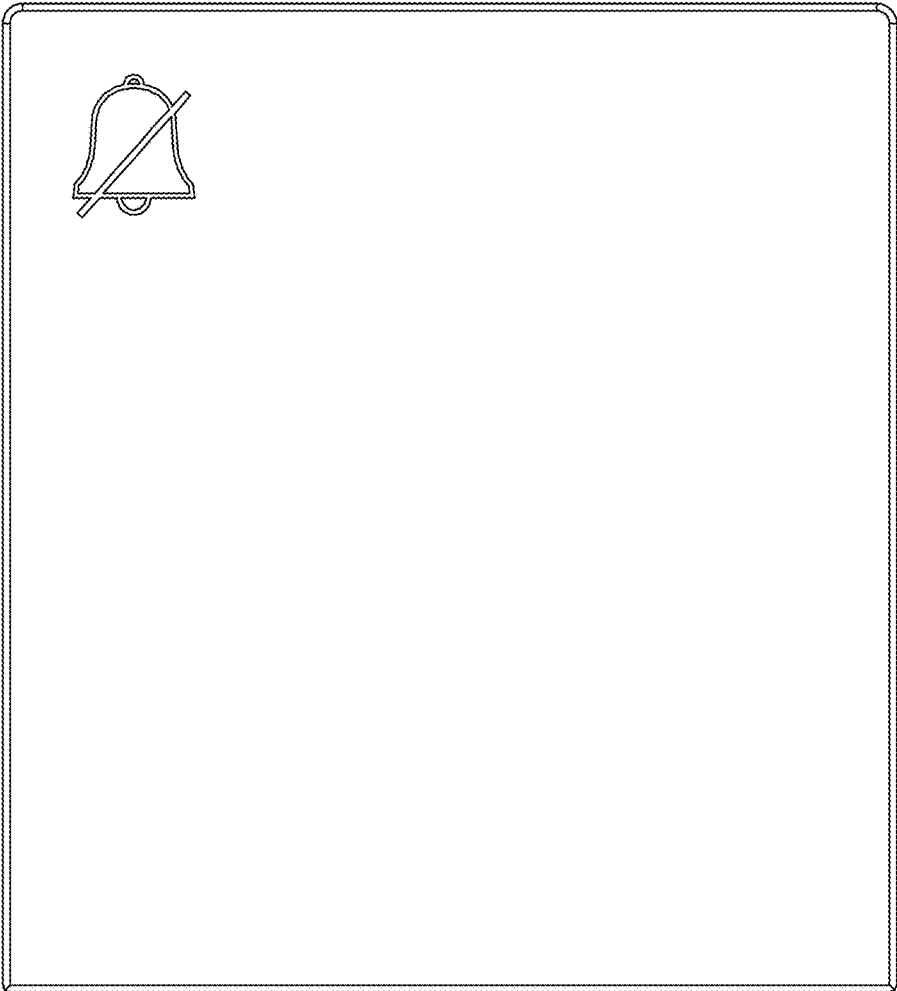

Fig. 9

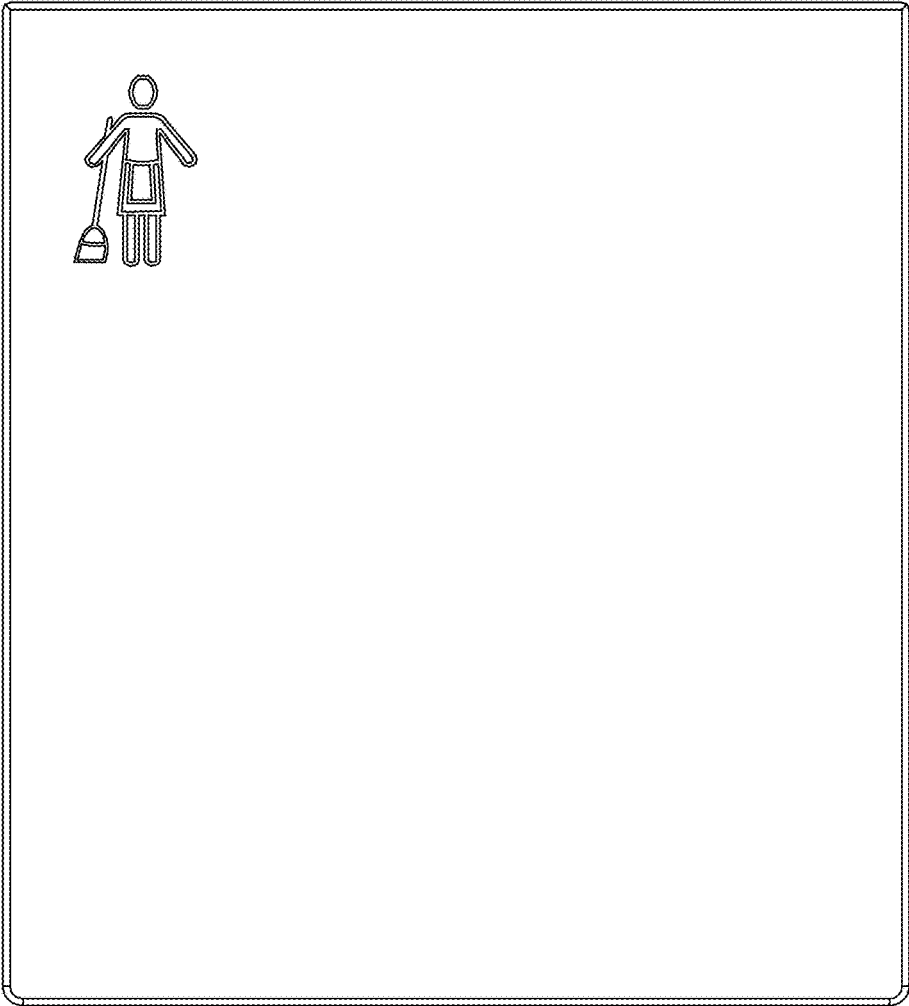

Fig. 10

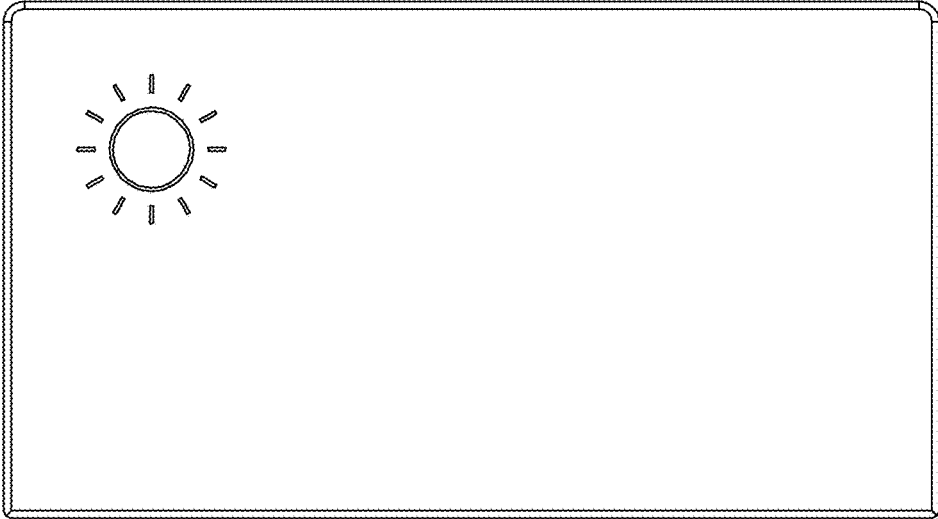

Fig. 11

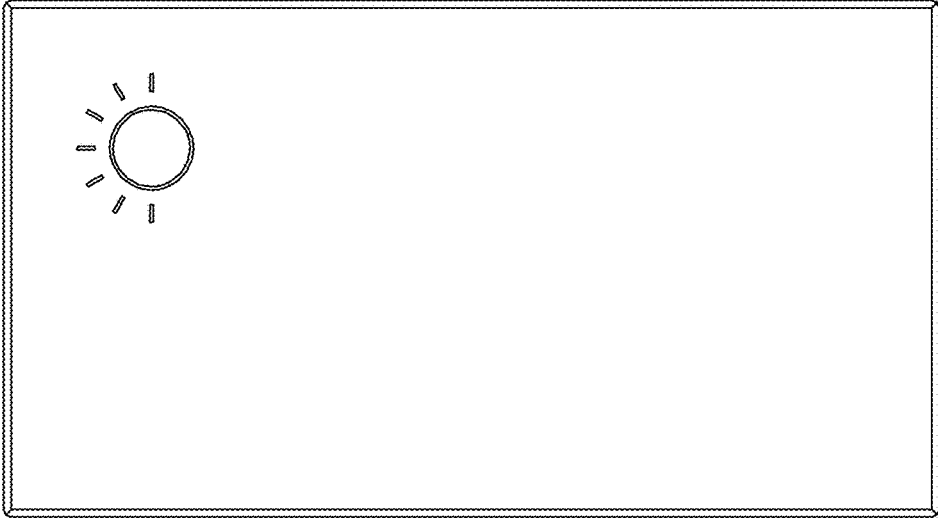

Fig. 12

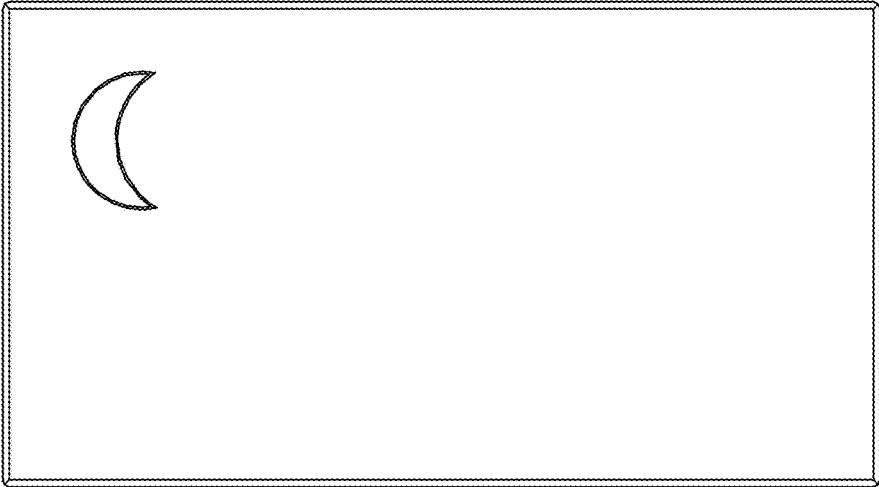

Fig. 13

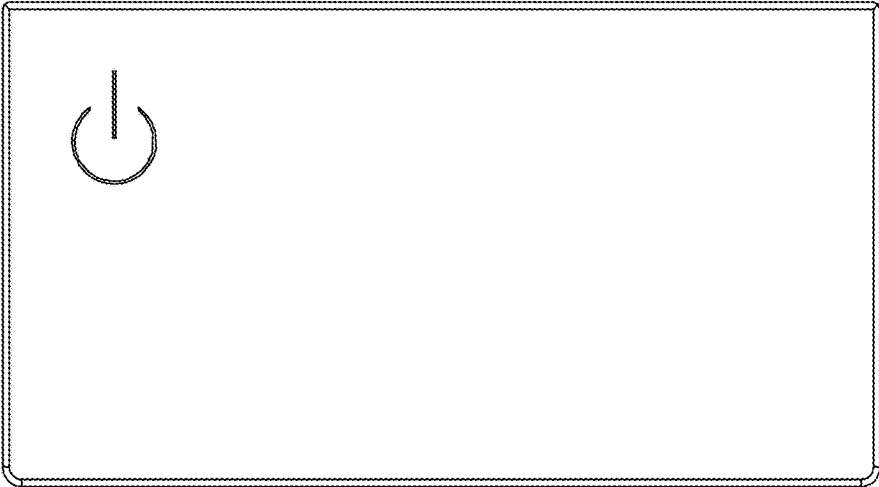

Fig. 14