



(86) Date de dépôt PCT/PCT Filing Date: 2012/11/09
 (87) Date publication PCT/PCT Publication Date: 2013/05/16
 (85) Entrée phase nationale/National Entry: 2014/04/14
 (86) N° demande PCT/PCT Application No.: EP 2012/072285
 (87) N° publication PCT/PCT Publication No.: 2013/068542
 (30) Priorités/Priorities: 2011/11/12 (EP11188915.0);
 2011/11/14 (US61/559,689)

(51) Cl.Int./Int.Cl. *A61F 2/24* (2006.01)
 (71) Demandeur/Applicant:
 MEDTENTIA INTERNATIONAL LTD OY, FI
 (72) Inventeurs/Inventors:
 KERANEN, OLLI, SE;
 ZERKOWSKI, HANS-REINHARD, CH
 (74) Agent: BENOIT & COTE INC.

(54) Titre : DISPOSITIF ET PROCEDE POUR AMELIORER LA FIXATION D'UN DISPOSITIF MEDICAL
 (54) Title: DEVICE AND METHOD FOR IMPROVING FIXATION OF A MEDICAL DEVICE

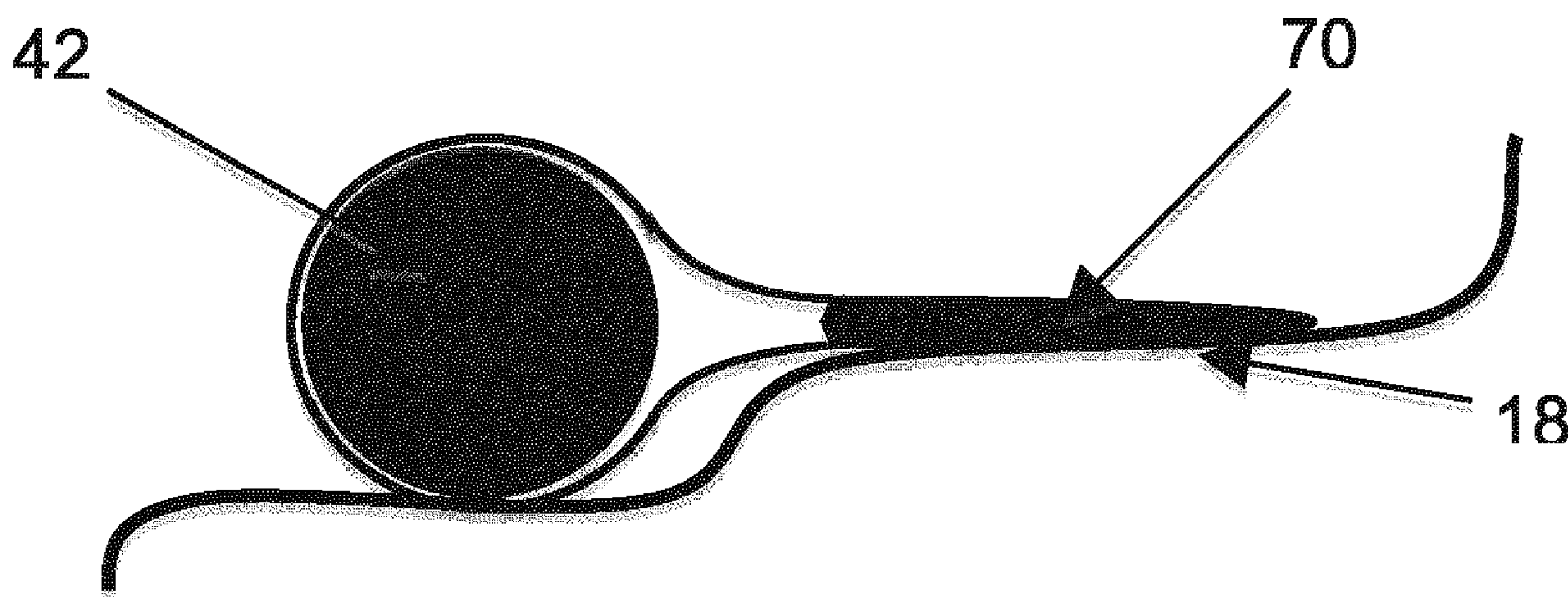

Fig. 18 b

(57) **Abrégé/Abstract:**

A device for improving the function of a heart valve comprises a first loop-shaped support, which is configured to abut a first side of the heart valve. A first flange unit is may be configured as a fabric sleeve covering the loop-shaped support. A portion of the fabric sleeve forms a flange that is attached to the annulus when said first loop-shaped support is abutting said heart valve. The flange is provideable by folding at least a portion of said sleeve over itself for forming a double layer of opposing fabrics thereof, such that said sleeve comprises a flange portion extending from said first loop-shaped support configured to overlap a surface of, and form a collar around, at least a portion of said annulus.



(12) INTERNATIONAL APPLICATION PUBLISHED UNDER THE PATENT COOPERATION TREATY (PCT)

(19) World Intellectual Property
Organization
International Bureau(43) International Publication Date
16 May 2013 (16.05.2013)(10) International Publication Number
WO 2013/068542 A1(51) International Patent Classification:
A61F 2/24 (2006.01)(21) International Application Number:
PCT/EP2012/072285(22) International Filing Date:
9 November 2012 (09.11.2012)

(25) Filing Language: English

(26) Publication Language: English

(30) Priority Data:
11188915.0 12 November 2011 (12.11.2011) EP
61/559,689 14 November 2011 (14.11.2011) US(71) Applicant: MEDTENTIA INTERNATIONAL LTD OY
[FI/FI]; Mäkelankatu 58-60 3rd Floor, FIN-00510 Helsinki
(FI).(72) Inventors: KERÄNEN, Olli; Anders Möllares väg 56, S-
237 41 Bjärred (SE). ZERKOWSKI, Hans-Reinhard;
Auf der Bischoffhohe, CH-4125 Riehen (CH).(74) Agent: KIPA AB; P O Box 1065, S-251 10 Helsingborg
(SE).(81) Designated States (unless otherwise indicated, for every
kind of national protection available): AE, AG, AL, AM,AO, AT, AU, AZ, BA, BB, BG, BH, BN, BR, BW, BY,
BZ, CA, CH, CL, CN, CO, CR, CU, CZ, DE, DK, DM,
DO, DZ, EC, EE, EG, ES, FI, GB, GD, GE, GH, GM, GT,
HN, HR, HU, ID, IL, IN, IS, JP, KE, KG, KM, KN, KP,
KR, KZ, LA, LC, LK, LR, LS, LT, LU, LY, MA, MD,
ME, MG, MK, MN, MW, MX, MY, MZ, NA, NG, NI,
NO, NZ, OM, PA, PE, PG, PH, PL, PT, QA, RO, RS, RU,
RW, SC, SD, SE, SG, SK, SL, SM, ST, SV, SY, TH, TJ,
TM, TN, TR, TT, TZ, UA, UG, US, UZ, VC, VN, ZA,
ZM, ZW.(84) Designated States (unless otherwise indicated, for every
kind of regional protection available): ARIPO (BW, GH,
GM, KE, LR, LS, MW, MZ, NA, RW, SD, SL, SZ, TZ,
UG, ZM, ZW), Eurasian (AM, AZ, BY, KG, KZ, RU, TJ,
TM), European (AL, AT, BE, BG, CH, CY, CZ, DE, DK,
EE, ES, FI, FR, GB, GR, HR, HU, IE, IS, IT, LT, LU, LV,
MC, MK, MT, NL, NO, PL, PT, RO, RS, SE, SI, SK, SM,
TR), OAPI (BF, BJ, CF, CG, CI, CM, GA, GN, GQ, GW,
ML, MR, NE, SN, TD, TG).

Declarations under Rule 4.17:

— of inventorship (Rule 4.17(iv))

Published:

— with international search report (Art. 21(3))

(54) Title: DEVICE AND METHOD FOR IMPROVING FIXATION OF A MEDICAL DEVICE

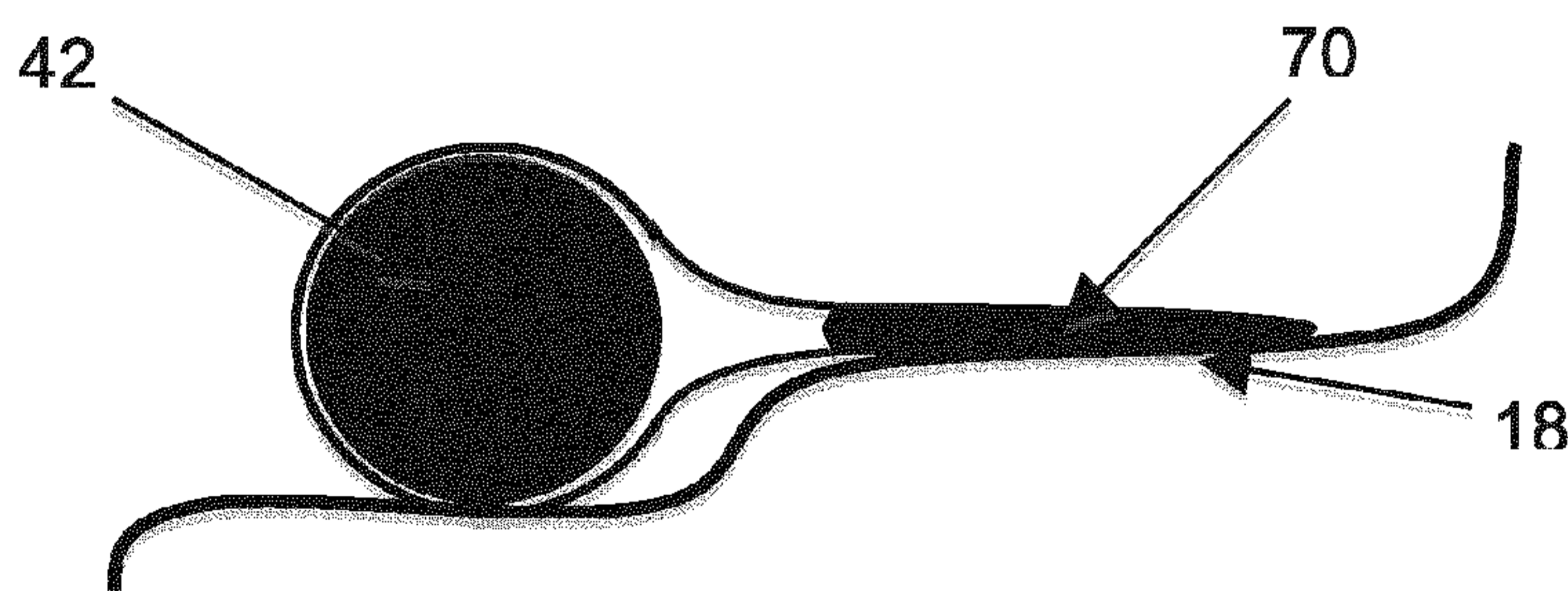

Fig. 18 b

(57) Abstract: A device for improving the function of a heart valve comprises a first loop-shaped support, which is configured to abut a first side of the heart valve. A first flange unit is may be configured as a fabric sleeve covering the loop-shaped support. A portion of the fabric sleeve forms a flange that is attached to the annulus when said first loop-shaped support is abutting said heart valve. The flange is provideable by folding at least a portion of said sleeve over itself for forming a double layer of opposing fabrics thereof, such that said sleeve comprises a flange portion extending from said first loop-shaped support configured to overlap a surface of, and form a collar around, at least a portion of said annulus.

WO 2013/068542 A1

TITLE

DEVICE AND METHOD FOR IMPROVING FIXATION OF A MEDICAL DEVICE

5 **Field of the Invention**

The present invention pertains in general to the field of fixation of medical devices, such as implants to body tissue at a patient. Some particular examples are related to repair or replacement of heart valves having various malformations and
10 dysfunctions. More specifically, some aspects of the invention relate to or are useful in heart valve repair techniques and/or medical procedures involving annuloplasty devices.

Background of the Invention

15 Medical devices frequently need to be fixated to body parts of a patient.

For instance, diseased mitral and tricuspid valves frequently need replacement or repair. The mitral and tricuspid valve leaflets or supporting chordae may degenerate and weaken
20 or the annulus may dilate leading to valve leak, i.e. an insufficiency of valve function. The leaflets and chords may become calcified and thickened rendering them stenotic, which implies obstructing a forward flow through the valve. Finally, the valve relies on insertion of the chordae inside the
25 ventricle. If the ventricle changes in shape, the valve support may become non-functional and the valve may leak. Mitral and tricuspid valve replacement and repair are traditionally performed with a suture technique.

During heart surgery, a premium is placed on reducing the
30 amount of time used to replace and repair valves as the heart is frequently arrested and without perfusion. In US 6,368,348, for example, an annulosplasty prosthesis is disclosed for supporting

an annulus of a heart valve. A biological tissue material covering may be provided tightly covering an interior carrier, preferably in its entirety (see e.g. claim 36 of 6,368,348). The prosthesis is devised to be stitched to the annulus of the heart
5 thus remodelling the same.

United States patent application no. US 2002/0173841 and United States Patent no. 6,419,696, which are assigned to the same assignee as the present application, disclose an annuloplasty device comprising a first and a second support
10 ring, which are connected to each other to form a coiled configuration. The first and second support rings are arranged to abut opposite sides of a valve annulus to trap valve tissue between them. This annuloplasty device may be easily applied to the valve by rotating the device into position on opposite sides
15 of the valve annulus. To ensure a proper and lasting fixation to the valve annulus such device can be fixated by barbs, retaining members, interlocking portions, fasteners or locking elements, all being integrated in the device. Fixation can also be accomplished by means of suturing. Paravalvular leakage is
20 another issue that is however not addressed in these disclosures.

United States Patent application no. US-2010-0145440-A1 of the same patent proprietor as the present disclosure discloses a device for improving the function of a heart valve that
25 comprises a first loop-shaped support, which is configured to abut a first side of the heart valve, and a first flange unit being connected to said first loop-shaped support. The flange unit is configured to be arranged against said annulus when said first loop-shaped support is abutting said heart valve. The
30 flange unit may provide sealing and deals thus with paravalvular leaks.

However, the prosthetic devices disclosed in the above mentioned documents might be further improved for a more convenient, faster positionable, and/or even more reliable device and method of valve repair and valve replacement. It is a
5 specific object of the invention to provide an alternative device, which allows for an easy and durable fixation to the valve annulus.

Furthermore, a desired improvement to be provided by improved devices and methods comprises allowing a prevention or
10 minimization of backflow of blood, e.g. passing by or underneath the prosthetic devices of the prior art.

Hence, an improved annuloplasty device and medical procedure would be advantageous, particularly one allowing for increased flexibility, cost-effectiveness, convenience and speed
15 of positioning, increased reliability and/or patient safety.

BRIEF SUMMARY OF THE INVENTION

An object of the invention is to provide an improved medical device and method of valve repair and valve replacement.
20 Another object of the invention may be to provide an annuloplasty device, which allows for an easy and durable fixation to the valve annulus.

Accordingly, embodiments of the present invention preferably seek to mitigate, alleviate or eliminate one or more
25 deficiencies, disadvantages or issues in the art, such as the above-identified, singly or in any combination by providing a medical device and a method according to the appended patent claims.

According to a first aspect of the invention, there is
30 provided a medical device for improving the function of a heart valve comprised of valve tissue including an annulus and a plurality of leaflets, the device comprising: a first loop-

shaped support, which is configured to abut a first side of the heart valve, and a fabric sleeve at least partly covering said first loop-shaped support, and which sleeve is sized to be folded over itself for forming at least a first flange unit.

5 This device may be used to perform annuloplasty, i.e. to reshape the valve annulus, in order to improve the function of the valve. The flange unit provides a well defined surface to be used when fixating the device against the annulus no matter if the device in use is positioned abutting the atrial or the
10 ventricle side of annulus. This implies that the device may easily be fixated to the annulus in a speedy manner. This is of importance since, during heart surgery, a premium is placed on minimizing time used to replace and repair valves as the heart is frequently arrested and without perfusion.

15 Also, the flange unit may provide for a sealing surface against said annulus allowing prevention of backflow of blood from the ventricle side to the atrial side.

In addition, the flange unit may be used for carrying or fixation of a prosthetic valve.

20 The sleeve may comprise a flange portion extending from said first loop-shaped support configured to overlap a surface of, and form a collar around, at least a portion of said annulus. The sleeve may comprise a casing portion configured to cover said first loop-shaped support and a flange portion extending
25 from said casing portion and configured to overlap a surface on the annulus.

The flange formed is in embodiments formed of a double layer of opposed fabrics of said sleeve.

In some embodiments, the flange is arranged radially outwards
30 from said loop-shaped support.

The device may further comprise a second loop-shaped support, which is configured to abut a second side of the heart

valve opposite to said first side, whereby a portion of the valve tissue is trapped between the first and second supports. The trapping of valve tissue between the first and second loop-shaped supports implies that the desired shape of the valve, whether natural or prosthetic, may be fixated. Further, the trapping implies that the device may temporarily be kept in correct position while fixating the device permanently to an annulus by means of e.g. sutures or clips.

The first loop-shaped support may be formed continuously with the second loop-shaped support to form a substantially coil-shaped body. This implies that the device and its coil-shape may be applied at a commissure between the leaflets of the heart valve and be rotated approximately 360° such that one loop-shaped support is inserted through the commissure to extend along one side of the valve and the other loop-shaped support is arranged along the opposite side of the valve. Thus, valve tissue will be trapped between the supports to fixate a desired shape of the valve. Depending on the extension of the flange means, the latter may provide an attachment surface on one of or on both sides of the annulus for fixation of the device.

The first flange unit may extend from the first loop-shaped support to the second loop-shaped support, whereby the flange unit may be configured to be arranged against the annulus on opposite sides of the valve tissue being trapped between the first and second supports. This implies that the flange unit may form a flange surface on both sides of the annulus or heart valve, which surface may provide for fixation, not only of the device but also of a prosthetic valve. Further, the flange unit may form a sealing surface that, depending on the position of the device, allows reduction or prevention of possible backflow of blood from the ventricle side to the atrial side.

The second loop-shaped support may comprise a second flange unit being connected thereto, which flange unit may be configured to be arranged against the annulus on a side thereof being opposite the first loop-shaped support when the second
5 loop-shaped support is abutting the heart valve. This allows prevention of paravalvular leakage.

At least one of the first and second flange units may be adapted to form a connection of at least one of the loop-shaped supports and a prosthetic valve against the annulus. This
10 implies a rapid fixation, which is of importance since during heart surgery a premium is placed on reducing the time required.

At least one of the first and second flange units may have an intermittent or continuous extension along the periphery of its corresponding loop-shaped support. By way of example, in
15 case of an intermittent extension, the flange unit may be formed by two local sections diametrically opposing each other, whereby the two sections, when the device is positioned in the heart valve, are abutting the commissures and form a sealing surface thereto.

At least one of the first and second flange units may be
20 made of a fabric material. The fabric material may be a woven material. A fabric has the advantage that it presents a rough surface enhancing ingrowth or anchoring of endothelia. Further, a fabric is easily penetrated by sutures or clips. Also, a
25 fabric allows the flange unit to be easily conformed to the annulus.

The fabric material may be impregnated with or integrate a pharmaceutical agent further improving embodiments of the devices and method. The pharmaceutical agent may for instance be
30 an anti inflammatory, stenosis preventing, or endothelialization promoting agent.

Further, at least one of the first and second flange units may comprise a reinforcing element. The reinforcing element provides an indication and definition of an area in which clips or sutures are to be put when fixating the medical device to the annulus. Further, the reinforcing element contributes to reducing the risk of pockets being formed along the circumferential surface. Also, the element prevents unthreading of the fabric in the flange.

At least one of the first and second flange unit may protrude or extend out from and form an angle α (see e.g. Fig. 5) of approximately 30-60°, such as e.g. approximately 40-50° below a diametric plane formed by one of the loop-shaped supports. By the flange unit initially extending below the diametric plane, the visibility during insertion is enhanced. In some embodiments, during insertion, the flange unit due to inherent flexibility may be folded, e.g. downwards in Fig. 5, even folded back over its point of fixation relative the diametric plane, or above the diametric plane with an outer edge of the flange unit. The point of fixation of at least one of the flange unit may be fixed in relation to the diametric plane, radially outward from at least one of the loop-shaped supports.

The flange unit may protrude with other angles, even in a fold back, i.e. more than 90°. This may be during or prior to a time of use or implantation thereof. The angle may be variable over time, e.g. to the herein described shape memory effect of some embodiments of the flange unit.

The flange unit may in some embodiments be arranged to change shape during insertion, e.g. by a resilient arrangement thereof. The flange unit may also be made of a shape memory material that returns to a pre-defined shape of form during insertion of the medical device, e.g. by a temperature triggered effect as known in the art of shape memory materials.

At least one of the first and second flange units extends radially inwards or outwards from its corresponding loop-shaped support. A radially inward extension provides a support for the valve leaflets, whereas a radially outward extension provides a support against the annulus. The first side of the heart valve is the atrial side and the second side is the ventricle side.

At least one of the first and second flange unit or a flange unit extending over first and second loop-shaped supports may be a sleeve covering the first and/or second loop-shaped support. The sleeve comprises a sealing fabric portion that can be drawn radially outward from the loop-shaped support and is configured to be squeezed or flattened to form a collar that is used to fixate (or attach) the device to the valve tissue. For example the sleeve may be drawn radially away from the loop-shaped support such that the fabric of the sleeve can be secured to the valve tissue by suturing or stapling the fabric of the sleeve to the valve tissue. The collar may also provide a seal that prevents leakage of blood between the two sides of the heart valve.

According to a second aspect of the invention there is provided a method for producing a medical device. The method comprises the steps of: providing a first loop-shaped support, which is configured to abut a first side of the heart valve, providing a fabric sleeve, at least partly covering said first loop-shaped support with said sleeve, and forming at least a first flange by folding at least a portion of said sleeve over itself for forming a double layer of opposing fabrics thereof.

According to a further aspect of the invention there is provided a method for repairing a heart valve comprised of valve tissue including an annulus and a plurality of leaflets for allowing and preventing blood flow, the method comprising: inserting a device comprising at least one loop-shaped support

and at least one flange unit being connected to the loop-shaped support to a heart valve, positioning the loop-shaped support such that it abuts a first side of the heart valve, positioning the flange unit such that it abuts the annulus, and fixating the device by attaching the flange unit to the annulus. The flange may comprise a fabric sleeve covering the loop-shaped support that is sutured, stapled, or otherwise attached to the annulus and thereby fix the device in place.

The method may comprise folding at least a portion of said sleeve over itself for forming a double layer of opposing fabrics thereof, such that said sleeve comprises a flange portion extending from said first loop-shaped support configured to overlap a surface of, and form a collar around, at least a portion of said annulus.

The method may further comprise the steps of: extending said flange portion of said sleeve away from said first loop-shaped support to form a flange overlapping a portion of said annulus and attaching said flange to said annulus.

The device may be inserted into the heart valve by using a catheter, whereupon the catheter is withdrawn leaving the device in said heart valve.

The method may further comprise the step of sealing said flange unit against said annulus with a sealing surface of said flange unit before securing the device. The sealing said flange unit against said annulus may reduce or eliminate paravalvular leakage from a ventricle side to said atrial side of said heart valve by said sealing.

The method may further comprising the step of reducing or preventing a backflow of blood from a ventricle side to said atrial side of said heart valve by said sealing.

The advantages provided by a device having a flange unit have previously been described hereinabove. The inventive method

for repairing a heart valve uses a corresponding device, whereby at least the same benefits are achieved.

The flange unit may be attached to the annulus by sutures or clips for a quick and easy fixation using well established
5 means. Alternatively, or in addition, barb elements or tissue adhesives may be used for the attachment to the annulus.

The provision of a flange unit implies that a smooth transition section may be formed between the outer periphery of the device and annulus. Further, the flange unit presents a well
10 defined and easy detectable surface for attachment of the clips or sutures. A smooth transition section as well as a well defined attachment surface allows for a smooth formation and growth of endothelia. Endothelia formation may further be improved by an endothelialization agent. For a flange unit
15 comprising a fabric sleeve, the endothelialization agent may be impregnated in or applied to a surface of all or a portion of the fabric and/or the fibers of the sleeve.

The flange unit may be conformed to the annulus before fixating the device. By conforming the flange unit, the
20 transition section may be additionally smoothed, further enhancing growth of endothelia.

The device may be inserted to the heart valve by using a catheter, whereupon the catheter is withdrawn leaving the device.

25 In the method the first side of the heart valve may be the atrial side.

Further, in another aspect, the invention provides a kit comprising a device for improving the function of a heart valve comprised of valve tissue including an annulus and a plurality
30 of leaflets, the device comprising: a first loop-shaped support, which is configured to abut a first side of the heart valve, and a first flange unit being connected to the first loop-shaped

support, and which is configured to be arranged against the annulus when the first loop-shaped support is abutting the heart valve, and an artificial valve.

This device may be used in a medical procedure to perform annuloplasty, i.e. to reshape the valve annulus, in order to improve the function of the valve. The flange unit provides a well defined surface to be used when fixating the device against the annulus. This implies that the device may be fixated to the annulus very easily and in a speedy manner. The latter is of importance since, during heart surgery, a premium is placed on reducing the amount of time used to replace and repair valves as the heart is frequently arrested and without perfusion. Also, the flange unit provides a sealing surface against the annulus allowing prevention of backflow of blood from the ventricle side to the atrial side. The number of steps and time required for valve replacement surgery are reduced by the device carrying an artificial prosthetic valve. Additionally, the positioning of the prosthetic valve in relation to the annulus is facilitated.

The device may further comprise a second loop-shaped support, which is configured to abut a second side of the heart valve opposite to the first side, whereby a portion of the valve tissue is trapped between the first and second supports. The trapping of valve tissue between the first and second loop-shaped supports implies that the desired shape of the valve may be fixated. Further, the trapping implies that the device may temporarily be kept in correct position while substantially fixating the device permanently to an annulus by means of e.g. sutures or clips.

The first loop-shaped support may be continuous with the second loop-shaped support to form a coil-shaped body. This implies that the device and its coil-shape may be applied at a commissure between the leaflets of the heart valve and be

rotated 360° such that one loop-shaped support is inserted through the commissure to extend along one side of the valve and the other loop-shaped support being arranged along the opposite side of the valve. Thus, valve tissue will be trapped between
5 the supports to fixate a desired shape of the valve. Depending on the extension of the flange means, the latter may provide an attachment surface on one of or on both sides of annulus for fixation of the device.

The first flange unit may extend from the first loop-shaped
10 support to the second loop-shaped support, whereby the flange unit may be configured to be arranged against the annulus on opposite sides of the valve tissue being trapped between the first and second supports. This implies that the flange unit may form a surface on both sides of the heart valve, which surface
15 may be used for fixation, not only of the device but also of a prosthetic valve. Further, the flange unit may form a sealing surface that, depending on the position of the device, allows prevention of possible backflow of blood from the ventricle side to the atrial side.

The second loop-shaped support may comprise a second flange
20 unit being connected thereto, which flange unit may be configured to be arranged against the annulus on a side thereof being opposite the first loop-shaped support when the second loop-shaped support is abutting the heart valve. This allows
25 prevention of paravalvular leakage.

At least one of the first and second flange units may have an intermittent or continuous extension along the periphery of its corresponding loop-shaped support. By way of example, in case of an intermittent extension the flange unit may be formed
30 by two local sections diametrically opposing each other, whereby the two sections, when the device is positioned in the heart

valve, are abutting the commissures forming a sealing surface thereto.

At least one of the first and second flange units may be made of a fabric material. A fabric has the advantage that it presents a rough surface enhancing growth of endothelia. Further, a fabric is easily penetrated by sutures or clips. Also, a fabric allows the flange unit to be easily conformed to the annulus.

Further, at least one of the first and second flange units may comprise a reinforcing element. The element provides an indication and definition of the area in which clips or sutures are to be put when fixating the device to the annulus. Further, the element reduces the risk of pockets being formed along the circumferential surface. Also, the element prevents unthreading of the fabric in the flange.

At least one of the first and second flange units may extend out from and form an angle of 30-60°, such as 40-50° below a diametric plane formed by one of the loop-shaped supports. By the flange unit initially extending below the diametric plane, the visibility during insertion is enhanced.

At least one of the first and second flange units may extend radially inwards or outwards from its corresponding loop-shaped support.

The artificial prosthetic valve may be arranged on one of the loop-shaped supports. In the case the device is intended to be inserted to the heart from the atrial side, the artificial valve is preferably arranged on the support intended to be positioned on the atrial side of annulus and vice versa.

Further, in another aspect, the invention may relate to a method for replacing a heart valve comprised of valve tissue including an annulus and a plurality of leaflets for allowing and preventing blood flow, the method comprising: inserting a

device comprising an artificial valve, at least a loop-shaped support and at least one flange unit being connected to the loop-shaped support to a heart valve, positioning the loop-shaped support such that it abuts a first side of the heart valve, positioning the flange unit such that it abuts the annulus, and fixating the device by attaching the flange unit to the annulus.

The advantages provided by a device having a flange unit and an artificial valve have previously been discussed above. The inventive method for replacing a heart valve uses a corresponding device, whereby the same benefits are achieved.

The flange unit may be attached to the annulus by using suitable fixation units, e.g. sutures or clips, which allows for a quick fixation using well established means.

The flange unit may be conformed to the annulus before fixating the device. By conforming the flange to the annulus, the surface to be covered by endothelia is reduced, allowing the growth to be enhanced and accelerated.

The device may be inserted to the heart valve by using a catheter, whereupon the catheter is withdrawn leaving the device.

In the method, the first side of the heart valve is preferably the atrial side.

The artificial valve may be arranged on one of said loop-shaped supports.

Further embodiments of the invention are defined in the dependent claims, wherein features for the second and subsequent aspects of the invention are as for the first aspect mutatis mutandis.

Some embodiments of the invention provide for a reduced amount of time used to repair and/or replace cardiac valves.

Some embodiments of the invention also provide for a reduced or prevented backflow of blood, e.g. by a smooth transition section formed between the outer periphery of the device and annulus.

5 Some embodiments of the invention provide for a more convenient repair, e.g. by means of a well defined surface for attachment of fixating means such as sutures or clips.

Some embodiments of the invention provide for a smooth formation and growth of endothelia.

10 It should be emphasized that the term "comprises/comprising" when used in this specification is taken to specify the presence of stated features, integers, steps or components but does not preclude the presence or addition of one or more other features, integers, steps, components or groups
15 thereof.

BRIEF DESCRIPTION OF THE DRAWINGS

These and other aspects, features and advantages of which embodiments of the invention are capable of will be apparent and
20 elucidated from the following description of embodiments of the present invention, reference being made to the accompanying drawings, in which

Fig.1a schematically illustrates a patient with a heart shown in cross-section and a device of an embodiment of the present
25 invention schematically illustrated as supporting the mitral valve;

Fig. 1b is a cross-sectional view of the left ventricle showing the mitral valve in perspective;

Fig. 2 is a perspective view of a body of a device according to
30 a first example of the invention;

Fig, 3 is a cross-sectional view of the body in Fig. 2;

Fig. 4 is a perspective view of the first example of the device comprising the body shown in Fig. 2;

Fig. 5 is a cross-sectional view of the device in Fig. 4;

Fig. 6 is a perspective view of a second example of the device;

5 Fig. 7 is a perspective view of a third example of the device;

Fig. 8 is a perspective view of a fourth example of the device;

Fig. 9a, 9b are perspective views that illustrate insertion of an example of the device;

Fig. 10 is a cross-sectional view showing an example of the
10 device inserted in a heart valve;

Fig. 11 and 12 are schematic illustrations that show a heart valve before and after remodelling by using the device;

Fig. 13 is a cross sectional view that shows the device fixed to the annulus;

15 Fig. 14a is a cross sectional view that shows a first example of the device comprising an artificial prosthetic heart valve;

Fig. 14b is a cross sectional view that shows a second example of the device comprising an artificial valve;

Fig. 15 is a cross-sectional view of an alternative device
20 having one loop-shaped support carrying the flange unit;

Fig. 16a, 16b are cross sectional views of examples involving a shape change; and

Fig. 17 is a cross sectional view schematically illustrating a flange unit having barb elements for affixing to tissue; and

25 Fig. 18a-b show cross-sectional views of embodiments comprising a fabric flange unit.

DETAILED DESCRIPTION OF THE INVENTION

Specific embodiments of the invention will now be described
30 with reference to the accompanying drawings. This invention may, however, be embodied in many different forms and should not be construed as limited to the embodiments set forth herein;

rather, these embodiments are provided so that this disclosure will be thorough and complete, and will fully convey the scope of the invention to those skilled in the art. The terminology used in the detailed description of the embodiments illustrated in the accompanying drawings is not intended to be limiting of the invention. In the drawings, like numbers refer to like elements.

Fig. 1A illustrates a patient **10** having a heart **12** shown in cross-section including a left ventricle **14** and a right ventricle **16**. The concepts of the present invention are suitable to be applied, for example, to a mitral valve **18**, which supplies blood into left ventricle **14**. Mitral valve **18**, as better shown in **Fig. 1B**, includes an annulus **20** and a pair of leaflets **22, 24** which selectively allow and prevent blood flow into left ventricle **14**. It will be appreciated that the term valve tissue is used extensively throughout this disclosure in reference to the drawings. The inventive principles are equally applicable when referring to any valve tissue such as annulus tissue, leaflet tissue or other attached vessel tissue. Leaflets **22, 24** are supported for coaptation by chordae tendinae or chords **26, 28** extending upwardly from respective papillary muscles **30, 32**. Blood enters left ventricle **14** through mitral valve **18** and is expelled during subsequent contraction of heart **12** through aortic valve **34**. It will be appreciated that the present invention is applicable to tricuspidal heart valves as well.

A body **41** comprised in a device **40** according to a first example of the present invention is shown in **Figs. 2 and 3**. The body **41** comprises a first and a second loop-shaped support **42, 44**.

As used herein, the term "loop-shaped" should be construed as a curved shape that may be closed, as at least a part of a ring with e.g. a circular, elliptic, or D-shaped form or any

other closed form which may fit the shape of the valve annulus. The term "loop-shaped" also includes a curved shape that is open forming an arcuate shape, such as a C-shape or U-shape, which includes an angular turn of at least 180° such that the support
5 may abut valve tissue along a major part of the annular valve shape. The term "loop-shaped" also includes a curved shape overlapping itself to form a portion of a coil. The term "loop-shaped" also includes three-dimensional curves.

The loop shape of at least a part of at least one of the
10 supports **42**, **44** may also in some embodiments be patient configured. The shape may be designed specifically to an anatomy of a patient. The patient specific loop shape may be virtually derived from 3D patient data, e.g. acquired by image modalities, such as Magnetic Resonance (MR) or Computer Tomography (CT)
15 Imaging.

In co-assigned US 6,419,696, US 6,730,121, US 6,964,684, and WO 2006/091163, which are incorporated by reference herein in their entirety for all purposes, devices are disclosed for repairing and replacing a heart valve in various embodiments.
20 The devices include at least first and second support rings connected together in loop-shaped configurations to abut opposite sides of a valve annulus. A replacement valve may be secured to the loop-shaped devices.

The first support **42** may be continuous and/or integral with
25 the second support **44** such that the supports **42**, **44** assume a coiled configuration in the form of a spiral or keyring-type configuration with two loops.

The second support **b** may have an outer boundary or extent which is greater in relation to the outer boundary of the first
30 support **42**. The supports **42**, **44** may in an embodiment have corresponding shapes with the second support **44** being in larger scale than the first support **42**. This is advantageous in

creating a pinch of the valve tissue between the first **42** and second supports **44**.

An end **45** of the second support **44**, which will lead the coil during insertion of the device at the valve, may in an embodiment have a greater pitch than the rest of the coil. This implies that the leading end **45** of the coil during rotation into position in the valve will project from immediate contact with the valve tissue and, therefore, the risk that the coil is caught by the chords is diminished.

10 The body **41** is shown in cross-section in **Fig. 3**. The body **41** has in an embodiment at least partly a round cross-sectional shape. In other embodiments, the cross section of the body **41** may be substantially flat, oval, flattened and/or have flattened edges. The opposed surfaces **46** provide a pinch to trap valve
15 tissue there between. A round cross-section is also advantageous in creating a pinch of the valve tissue which will not harm the leaflets in their movement during normal heart action.

The second loop-shaped support **44** is slightly displaced radially with respect to the first loop-shaped support **42**. This
20 implies that the first and second loop-shaped supports **42**, **44** are not arranged directly on top of each other in some embodiments. The pinch between the first **42** and second supports **44** is therefore not sharply defined in a radial direction of the valve. This implies that a pinching force between the supports
25 is not focussed to a specific radial position of the valve. As a result, the pinching force does not affect the movement of the leaflets during normal heart action and there is a diminished risk of rupture in the leaflets at the pinch.

The supports may in some embodiments be interrelated in
30 such manner that the outer boundary of the first support **42** has a diameter corresponding to a line through the centre of the second support **44**. Thus, the supports **42**, **44** may overlap

somewhat such that tissue is not allowed to move through the pinch and the shape of the valve is maintained advantageously.

Further, the cross-section of the supports **42**, **44** is substantially round, which also gives a soft contact between the supports and the valve tissue to further diminish the risk of rupture in the leaflets. The body **41** may be formed from a core of a rigid material, such as a metal, e.g., titanium, or plastic. Any suitable medical grade material(s) may be used.

The rigid material may provide a passive spring function such that the loops of the coil may be forced a small distance away from each other but will flex back towards each other when the force is released. The core of the body **41** may be coated by a softer layer, such as a textile.

The body **41** may alternatively be formed from a shape memory material. The body **41** will then assume a desired, programmed shape, when e.g. heated to a specific temperature. This allows the body **41** to be compressed or straightened of the form better suited for delivering during insertion and to assume a spiral shape when inserted at the heart valve. Also, the flange unit may be made of such a shape memory material, e.g. to provide a first, delivery shape and a second, delivered shape thereof.

A first example of the medical device **40** is disclosed in **Figs. 4 and 5**. The device **40** comprises a body **41** in accordance with that described above with reference to **Figs. 2 and 3**. The device **40** comprises a flange unit **50** being connected to the body **41** and more precisely to the first loop-shaped support **42**. The flange unit **50** has in an embodiment a continuous extension along the periphery of the first loop-shaped support **42**.

In some examples, the flange unit **50** may be integral with at least a portion of the body **41**, as e.g. shown in **Fig. 16a**.

In some embodiments the flange unit **50** is made of a tube shaped flexible material **52** being passed onto the first loop-shaped

support **42**, whereby a loose substantially co-axial connection between the loop-shaped support and the flange unit is achieved. The connection may also be fixed or rigid. The flexible material may by way of example be a fabric or woven structure made of
5 Polyethylene (PE) or polytetrafluoroethylene (PTFE). A fabric has the advantage that it presents a rough, holed or porous surface enhancing growth of and overgrowth of endothelia. Further, a fabric is easily penetrated by sutures or clips. In addition, the flexible material allows the flange unit **50** to be
10 conformed to the annulus.

The flange unit **50** does in the disclosed embodiment form a flange surface **54** extending downwards out from the body. More precisely the flange unit **50** forms in some embodiments and angle α to a horizontal, diametric plane formed by the first loop-
15 shaped support. The angle α is approximately between 30-60°, such as 40-50° to the diametric plane. Such angle improves the visibility during insertion of the device. In some embodiments, improved visibility may be provided during insertion of the device, whereupon the flange unit **50** changes shape to a position
20 facilitating fixation thereof to surrounding tissue. Thus, medical procedures for heart valve repair and/or replacement may be speeded up considerably.

In a practical embodiment the flange surface **54** has a width in the range of approximately 2-4 mm such as 2.5-3.5 mm. The
25 width of the flange radially outwards allows an indication for the surgeon of the area in which sutures or clips should be positioned when fixating the device to the annulus. This is further discussed below with reference to **Fig. 13**.

Initially, before inserted into the heart valve, the flange
30 surface **54** extends downwardly. When positioned in the atrial side of the heart valve, the device will be arranged abutting the annulus whereby the flange unit will be conformed to the

annulus, changing its angle from extending downwardly to extending upwardly. This ability to conform is a combination of the flexibility of the (fabric) material and the width of the flange means.

5 On its outer periphery, the flange unit **50** may comprise a reinforcing element **65**, which is schematically illustrated in **Fig. 4**. Such reinforcing element may by way of example have the form of a thread or a bead.

Figs 18a, 18b, and 18c show cross-sectional views of a
10 loop-shaped support and a flange unit comprising a fabric sleeve **70** that covers the looped-shaped support **42**.

The sleeve **70** can be positioned on an annuloplasty implant by sliding it onto one or more of loop-shaped supports **42, 44** from either end of the annuloplasty body. Alternatively, the sleeve
15 **70** may be made from a flat piece of fabric (not shown) that is folded over the annuloplasty implant along its longitudinal axis. The lateral ends of the thus folded fabric may be sewn together or otherwise suitably attached to each other. This may e.g. be done using integrated fastening means in them upon
20 longitudinally folding over, opposing fabric portions by fastening units. Fastening units may be of the hook and loop type fastening means allowing an easy assembly. This may be advantageous when the implant body has varying cross sections and the sleeve is only to be provided at a longitudinal portion
25 intermediate ends of the implant and at a section with reduced cross section. In this manner, the sleeve may also be prevented from sliding longitudinally along the implant body without the need for longitudinal fixation units.

The longitudinal folded over section with opposing fabric
30 sections may be provided as a pre-fabricated flange unit. That means the double layer of opposed fabrics may be provided as a

substantially flat sub-section extending radially outwardly from at least a longitudinal portion of the support **42** and/or **44**.

The sleeve **70** may be closed at one end and designed with a specified length such that the open end of the sleeve is positioned at a desired location on at least one of the supports **42, 44** when the sleeve is slid into place and fully extended along a length of the support. The inner cross-sectional diameter of the sleeve **70** is greater than the cross-sectional diameter of the support such that the sleeve loosely covers all or a portion of the support **42** and/or **44** with enough slack in the sleeve **70** to allow the fabric of the sleeve to overlap a surface of the annulus **18** (**FIG. 18b**) and form a collar around a portion or all of the circumference of the annulus.

The sleeve, in some embodiments, is thus oversized in relation to the outer cross section of the annuloplasty implant, namely one or more of the supports **42** and/or **44**. This may of illustrative reasons not be shown in all figures.

It should be noted that, even illustrations like Figs. 5, 10, 13, 14a, 14b, 15, 16a, 16b, and 17, where the reader might have the impression that the sleeve appears to be a single layer, like in Fig. 18c, should note that embodiments falling under the illustrations have a folded over, double layer, in particular formed from an oversized sleeve as shown in Figs. 18a-18b.

The loop-shaped support need not have a circular cross-sectional shape as shown in **FIGs. 18a-c** and may, for example have a cross-sectional shape as shown in **FIGs. 4 and 6-9**.

Different support element **42** and/or **44**.

Alternatively, or in addition, a longitudinal section of the oversized sleeve may be partly flattened radially outwardly.

Thus opposing fabric sections may be provided as a pre-fabricated flange unit allowing easy gripping, and an advantageous final shaping by the surgeon upon implantation. That means the double layer of opposed fabrics may with a fold over at the radial
5 perimeter. The pre-fabricated sleeve portion is still provided on an oversized sleeve covering the support **42** and/or **44**. The pre-fabricated sleeve portion may be provided as a substantially flat sub-section extending radially outwardly from at least a longitudinal portion of the support **42** and/or **44**. By giving the
10 at least first flange a final shaping upon implantation, it is possible to customize the medical device for different patients and thereby enable the provision of a medical device, which can fit well together with a larger variety of sizes of heart valves. Thus, a more flexible and versatile medical device has been
15 achieved.

During placement of the annuloplasty device, the sleeve may be drawn radially away from the loop-shaped support to overlap valve tissue of the annulus as shown in **FIG. 18b** to form a flange. In some cases, the sleeve **70** may be drawn radially
20 inward to overlap valve tissue in the annulus **18**. In other cases, the sleeve may be drawn away from the loop-shaped support **42** in more than one direction to form more than one flange, for example a flange along the outer edge of the looped shaped support and a flange along the inner edge of the loop-shaped
25 support **42**.

The fabric between the annulus and support may then be tensioned while the flange portion of the sleeve **70** is secured to valve tissue in the annulus by suturing, clamping, or stapling the fabric of the sleeve **70** to the valve tissue.
30 Securing the sleeve **70** to the valve tissue of the annulus fixes the annuloplasty device in place and may optionally provide a seal that prevents leakage of blood between the two sides of the heart valve. The outer edge of the fabric may optionally be

folded back over itself one or more times before being sutured or otherwise secured to the annulus **18**.

FIG. 18c shows an alternative embodiment in which the sleeve **70** may be configured to comprise a casing portion **71** that fits over the loop-shaped support such that the sleeve may easily be slipped onto the support **42** or **44** from either end of the body **41**. The casing may be closed at one end and designed with a specified length such that the open end of the casing portion is positioned at a desired location on at least one of the supports **42**, **44** when the sleeve is slid into place with the casing portion fully extended. The sleeve **70** comprises a fabric flange portion **72** extending, usually outward, from casing **71**. The fabric comprising flange portion **72** may have a single, constant thickness or a thickness that varies along the axial length of the sleeve and/or along the radial length from the loop-shaped support **42**.

During placement of the annuloplasty device, the flange portion **72** of the sleeve may be drawn radially away from the loop-shaped support to overlap valve tissue of the annulus **18** to form a flange. In some cases, the flange portion **72** may be drawn radially inward to overlap valve tissue in the annulus. The fabric between the annulus and support may then be tensioned while the flange portion **72** is secured to the annulus **18** by suturing, clamping, or stapling the fabric of the flange portion **72** to the valve tissue. Securing the flange portion **72** to the valve tissue of the annulus fixes the annuloplasty device in place and may optionally provide a seal that prevents leakage of blood between the two sides of the heart valve.

A flange unit comprising a sleeve **70** with or without a casing **71** and a flange portion **72** has the advantage of being easy to manufacture and provides the option of placing the flange unit onto the annuloplasty device immediately before

implantation. Additionally, the sleeve **70** or casing **71** fits loosely around the body of the annuloplasty device so that the tensioning of the fabric of sleeve **70** rotates the sleeve or casing around the loop-shaped support(s) **42, 44** and ensures that
5 the rotational orientation of the flange with respect to the annuloplasty device body is correct. The fabric of the flange unit may advantageously be impregnated with, or have incorporated within it, one or more drugs. The flange unit may also advantageously be used as a site of attachment for a
10 prosthetic heart valve to the annuloplasty device.

Now turning to **Fig. 6**, a variant of the device **40** is disclosed. The device differs from that disclosed in **Figs. 4 and 5** in that the flange unit **50** extends from the first loop-shaped support **42** to the second loop-shaped support **44**. The flange unit
15 **50** may be formed in one piece or be separated into a first and a second piece, wherein the first piece is connected to the first loop-shaped support and the second piece is connected to the second loop-shaped support. The connection may be a rigid connection or a loose connection. The latter may be achieved by
20 the flange unit being passed onto the loop-shaped support(s).

The flange unit may be continuous or intermittent along its extension. The example is suitable no matter if the device is to be used for repairing or replacing a valve.

Now turning to **Fig. 7**, a third embodiment of the device **40** is disclosed. The device **40** differs from that disclosed in **Figs. 4 and 5** in that the flange unit **50** extends along the second loop-shaped support **44**. When positioned in the heart valve, the second loop-shaped support **44** is intended to abut the ventricle
30 side of the heart valve, whereas the first loop-shaped support **42** is intended to abut the atrial side. The flange unit **50** may be continuous or intermittent along its extension. The device

may be suitable when used in valve replacement. An artificial, i.e. prosthetic valve may be carried by either the body or the flange means.

Fig. 8 shows another variant of the device **40**. The device **40** differs from that disclosed in **Figs. 4 and 5** in that the flange unit **50** extends along the second loop-shaped support **44** and forms two flange surfaces **54**, both being connected to the second loop-shaped support **44**. The flange surfaces **54** are so arranged on the loop-shaped support **44** that they overlap the commissures when the device is arranged in the heart valve abutting the annulus. Thereby the two flange surfaces form a sealing preventing possible leakage of blood from the ventricle side to the atrial side.

In the above discussed embodiments of the device, the flange unit has been disclosed as being either continuous or intermittent along its extension. The flange unit may further have a non-uniform width varying along its extension. By way of example the width may be larger in a region corresponding to a position overlapping the commissure when the device is arranged in the heart valve abutting the annulus.

Referring now to **Figs. 9-11**, a method for repairing a heart valve will be described.

First, access to the heart valve is achieved by conventional techniques, including arresting the heart and opening the chest. Alternatively, an intraluminal catheter based delivery technique may be applied. In **Fig. 9a**, the device **40** is shown when being inserted to the mitral valve **18** from the atrial side. The device **40** is being carried on a carrier or tool (not shown), which is connected to a stem for remote control of the positioning of the carrier. An end **56** of the second loop-shaped support **44** is brought to the opening of the mitral valve **18** at a commissure **60** between the leaflets **22, 24**, as shown in **Fig. 9b**.

The end **56** is led through the opening and the carrier is turned 360 degrees. Thus, the second support **44** will be rotated into place on one side of the valve **18**, whereas the first support **42** and the flange unit is placed on the opposite side of the valve **18**. During this rotational movement the flange unit **50** is deflected from its original direction forming an angle of 30-60° downwards from the diametric plane formed by the support **42** to a direction extending in an angle upwards from the diametric plane corresponding to the wall formed by the annulus **20**. The deflection allowed by the flexibility of the flange unit **50** results in a close abutment between the flange unit **50** and the atrial side of the annulus **20**. If necessary, the flange unit **50** may be additionally conformed to the annulus **20**. In this way, the device **40** is arranged in engagement with the valve **18**, as shown in **Fig. 10**.

Further, the supports **42**, **44** are placed on opposite sides of the valve **18** pinching valve tissue between them to maintain a shape of the valve **18**. The leaflets **22**, **24** may now be drawn towards each other through the pinch of the support rings **42**, **44** so as to remodel the shape of the valve **18**. The leaflets may be drawn through the pinch by means of a forceps instrument. The supports **42**, **44** may flex away from each other to allow drawing leaflets **22**, **24** through the pinch and towards each other for preventing the leaflets **22**, **24** to slip back. The valve annulus **20** may in this way be remodelled and the new shape is maintained by the supports **42**, **44**, see **Figs. 11 and 12** showing before and after remodelling. In **Fig. 11** a defective closure region **400** of the valve leaflets **22**, **24** is shown. The supports **42**, **44** may have roughened, opposed surfaces **46** to better keep the leaflets **22**, **24** from slipping through the pinch and to hold the valve annulus **20** in its reshaped form.

The device **40** may now be secured to the valve **18** for strengthening the fixation of the relative position between the supports **42, 44** and the valve tissue, see **Fig. 13**. The fixation may be made by clips or sutures **62** which are arranged through
5 the flange unit **50** and its circumferential flange surface **54**. By the latter being made of fabric it is easily penetrated. The clips or sutures **62** are preferably oriented and positioned in the circumferential direction of the flange unit **50**. The number of fixation points is arbitrary for the provision of a durable
10 fixation.

The flange unit **50** provides in some embodiments a better seat and prevents sliding of the device **40**. Thus, the device **40** is positioned more stable in the procedure, which is advantageous, especially for long-term performance of the device
15 after insertion.

As illustrated in **Fig. 10**, the second support **44** is slightly displaced radially with respect to the first support **42**. This implies that the first and second supports **42, 44** are not arranged directly on top of each other. The pinch between
20 the first and second supports is therefore not sharply defined in a radial direction of the valve. This implies that a pinching force between the supports is not focussed to a specific radial position of the valve. As a result, the pinching force does not affect the movement of the leaflets during normal heart action
25 and there is a diminished risk of rupture in the leaflets at the pinch. The supports are interrelated in such manner that the outer boundary of the first support **42** has a diameter corresponding to a line through the centre of the second support **44**. Thus, the supports **42, 44** overlap somewhat such that tissue
30 is not allowed to move through the pinch and the shape of the valve is maintained. Further, the cross-section of the supports **42, 44** is round, which also gives a soft contact between the

supports and the valve tissue to further diminish the risk of rupture in the leaflets.

The method described above is applicable no matter the shape, position or extension of the flange means. Further, the method is applicable no matter if the device is inserted from the atrial side or the ventricle side.

A device having a flange unit on the first, upper loop-shaped support is suitable when the device is to be positioned on the atrial side, providing a fixation surface to the atrial side of the annulus. Such device is also suitable when carrying an artificial valve. Further, a device having a flange unit on the second loop-shaped support is suitable when the second loop-shaped support is to be positioned on the ventricle side of the heart valve.

A device having a flange unit extending from the first to the second loop-shaped support is suitable no matter if the device is positioned on the atrial side or the ventricle side of the heart valve.

With reference to **Fig. 14a** and **Fig. 14b**, it is to be understood that the device may be used for replacement of heart valves as well. For that purpose the device 40 comprises in addition to a body **41** and a flange unit 50 an artificial valve **64**. The flange unit **50** may be carried by the first loop shaped support **42** as is shown in Fig. 14a. Alternatively, as is shown in **Fig. 14b**, the flange unit **50** may extend from the first **42** to the second **44** support. Although not shown, it is to be understood that each support **42**, **44** may carry its own flange unit **50**, or that the flange unit may be carried by the second support **44** only.

The method of inserting, positioning and fixation of the device is generally the same as that used when repairing a heart valve, whereby the method as such is not further discussed.

It should be emphasized that the preferred embodiments described herein are in no way limiting and that many alternative embodiments are possible within the scope of protection defined by the appended claims.

5 By way of example, the device **40** and its body **41** has been disclosed as having a first **42** and a second **44** loop-shaped support. The device **40** is applicable with only one loop-shaped support carrying the flange unit **50**. One such embodiment is disclosed in **Fig. 15**.

10 Further, the access to the heart valve may be achieved endoscopically, or transluminally, catheter based. In such case, the device **40** needs to be inserted through a narrow tube (endoscope or catheter). This implies that the device **40** will need to be compressed during insertion in order to pass through
15 the endoscope or catheter. The device **40** needs to assume its proper shape after having been passed through the endoscope. Therefore, using an endoscopic or catheter based approach, the body may advantageously be formed from a shape memory material. This allows the device **40** to be compressed and also to have a
20 stable shape when being applied to the heart valve. In an alternative, the access to the heart valve may be achieved through a catheter, which is passed through the vascular system to the heart. In this case, the supports may be formed from a shape-memory material, which during insertion extends along the
25 catheter in a flexible state and, when pushed out of the catheter at the heart valve, assumes a pre-stressed coil-shape in order to abut the heart valve on opposite sides.

The first and second loop-shaped supports may be connected to each other by means of a connecting part so as to form a
30 coil-shape. The coil-shape of the device is advantageous during insertion, since the device may then be rotated into position, as described above. However, the connecting part is detachable

from at least one of the supports. Thus, when the device has been inserted, the connecting part may be detached and removed from the opening of the valve.

The loop-shaped support(s) and the flange unit may be provided as separate parts. Further, it is to be understood that the flange means, or at least a wing part thereof, may form an arbitrary angle to its corresponding loop-shaped support.

Fig. 16a, 16b are cross sectional views of embodiments involving a shape change. In **Fig. 16a** the change of shape of a flange unit **50** is illustrated, e.g. for being out of a line of sight for a surgeon during insertion (dotted line) and, when in contact with body tissue, turning to a second shape (continuous line) for attaching to the tissue.

In **Fig. 16a** the change of shape of a flange unit **50** is illustrated in two steps or directions. Firstly the flange unit may shrink in a first direction, in order to eliminate any wrinkles or folds therein. Subsequently or concurrently, the flange unit **50** may change shape in a second direction, e.g. as described with reference to **Fig. 16a**.

Fig. 17 is a cross sectional view schematically illustrating a flange unit **50** having barb elements **500** for affixing the device **40** to tissue. The flange unit **50** may thus be a carrier for fixation elements. The flange unit **50** may thus be inserted into the body more effectively.

In some embodiments, different materials may be used for parts of the device **40**. For instance, the inner rings **42, 44** may be made of a stiffer more stable than a more flexible outer part, e.g. the flange unit **50**.

In addition, or alternatively, in some embodiments (not shown) the double layer flange unit may be folded over towards the center of the device. The flange unit may additionally be provided with reinforcement sections or units, such as disclosed

in European Application number EP11188656.0 and U.S. Provisional Patent Application Serial No. 61/558,787, both of the same inventor as the present disclosure, and entitled "A DEVICE AND A METHOD FOR IMPROVING THE FUNCTION OF A HEART VALVE", which are
5 incorporated herein by reference in their entirety for all purposes. The reinforcement sections or units comprise more particularly one or more flexible leaflet reinforcement patch(es). A flexible leaflet reinforcement patch may thus be provided as a double layer fabric, which is configured to
10 provide reinforcement to at least one of the leaflets.

While several embodiments of the present invention have been described and illustrated herein, those of ordinary skill in the art will readily envision a variety of other means and/or structures for performing the functions and/or obtaining the
15 results and/or one or more of the advantages described herein, and each of such variations and/or modifications is deemed to be within the scope of the present invention as defined by the enclosed claims. More generally, those skilled in the art will readily appreciate that all parameters, dimensions, materials,
20 and configurations described herein are meant to be exemplary and that the actual parameters, dimensions, materials, and/or configurations will depend upon the specific application or applications for which the teachings of the present invention is/are used.

Those skilled in the art will recognize, or be able to ascertain using no more than routine experimentation, many equivalents to the specific embodiments of the invention described herein. It is, therefore, to be understood that the
25 foregoing embodiments are presented by way of example only and that, within the scope of the appended claims and equivalents thereto, the invention may be practiced otherwise than as specifically described and claimed. The present invention is
30

directed to each individual feature, system, article, material, kit, and/or method described herein. In addition, any combination of two or more such features, systems, articles, materials, kits, and/or methods, if such features, systems, 5 articles, materials, kits, and/or methods are not mutually inconsistent, is included within the scope of the present invention as limited by the appended patent claims.

CLAIMS

1. A medical device for improving the function of a heart valve
5 comprised of valve tissue including an annulus (18) and a
plurality of leaflets (22, 24), the medical device comprising:
a first loop-shaped support (42), which is configured to
abut a first side of the heart valve, and
a fabric sleeve (70) at least partly covering said first
10 loop-shaped support (42), and which sleeve (70) is sized to be
folded over itself for forming at least a first flange (50), and
the medical device being characterized in that said first flange
(50) is reshapeable for a final shaping upon implantation.
- 15 2. The device of claim 1, wherein said sleeve (70) comprises a
flange (50) portion extending from said first loop-shaped
support (42) configured to overlap a surface of, and form a
collar around, at least a portion of said annulus (18).
- 20 3. The device of claim 2, wherein said sleeve (70) comprises a
casing portion configured to cover said first loop-shaped
support (42) and a flange (50) portion extending from said
casing portion and configured to overlap a surface on the
annulus (18).
- 25 4. The device of any of claims 1-3, comprising said flange (50)
formed of a double layer of opposed fabrics of said sleeve (70).
5. The device of any of claims 2-5, wherein said flange (50) is
30 arranged radially outwards from said loop-shaped support (42).

6. The device of any of claims 2-5, further comprising a second loop-shaped support (42), which is configured to abut a second side of the heart valve opposite to said first side, whereby a portion of the valve tissue is trapped between the first and second supports, wherein the first loop-shaped support (42) is optionally continuous with the second loop-shaped support (42) to form a coil-shaped body.

7. The device of claim 6, wherein said second loop-shaped support (42) comprises a second flange (50) being connected thereto,

wherein:

said second flange (50) is configured to be arranged against said annulus (18) on a side thereof being opposite the first loop-shaped support (42) when said second loop-shaped support (42) is abutting said heart valve;

said second flange (50) comprises a fabric sleeve (70) covering said first loop-shaped support (42) and

said sleeve (70) comprises a flange (50) portion extending from said first loop-shaped support (42) configured to overlap a surface of, and form a collar around, at least a portion of said annulus (18).

8. The device of claim 7, wherein at least one of said first and second flange (50)s is adapted to form a connection of at least one of the loop-shaped support (42)s and a prosthetic valve against said annulus (18).

9. The device of claim 7 or 8, wherein at least one of said first and second flanges (50) has an intermittent extension along the periphery of its corresponding loop-shaped support (42).

10. The device of claim 7 or 8, wherein at least one of said first and second flange (50) units has a continuous extension along the periphery of its corresponding loop-shaped support
5 (42).

11. The device of any of claims 7-10, wherein at least one of said first and second flange (50) units comprises a reinforcing element.
10

12. The device of any of claims 1-11, wherein said device is configured to carry an artificial prosthetic heart valve.

13. The device of any of claims 1-12, wherein at least one of said first and second flanges (50) is configured to provide a sealing surface.
15

14. The device of any of claims 1-12, wherein at least one of said first and second flanges (50) is conformed to said annulus
20 (18) before fixation of the device.

15. A kit for improving the function of a heart valve comprising a medical device according to any of claims 1-14 and an artificial prosthetic heart valve attachable or attached to said
25 medical device wherein:

said first flange (50) comprises said fabric sleeve (70) configured to cover said first loop-shaped support (42);

said sleeve (70) comprises a flange (50) portion extending from said first loop-shaped support (42) configured to overlap a
30 surface of, and form a collar around, at least a portion of said annulus (18).

16. A method of producing a medical device of any of claims 1-14, the method comprising:

providing a first loop-shaped support (42), which is configured to abut a first side of the heart valve,

5 providing a fabric sleeve (70),

at least partly covering said first loop-shaped support (42) with said sleeve (70),

forming at least a first flange (50) by folding at least a portion of said sleeve (70) over itself for forming a double
10 layer of opposing fabrics thereof.

17. A method for repairing a heart valve comprised of valve tissue including an annulus (18) and a plurality of leaflets (22, 24) for allowing and preventing blood flow, said method

15 comprising:

a) inserting a medical device into said heart valve, said medical device comprising at least one loop-shaped support (42) and at least one flange unit (50);

b) positioning said loop-shaped support (42) such that it abuts
20 a first side of the heart valve; wherein:

said first flange unit (50) comprises a fabric sleeve (70) covering said first loop-shaped support (42) and

c) folding at least a portion of said sleeve (70) over itself for forming a double layer of opposing fabrics thereof, such
25 that said sleeve (70) comprises a flange portion extending from said first loop-shaped support (42) configured to overlap a surface of, and form a collar around, at least a portion of said annulus, and being characterized by

d) positioning said flange unit (50) such that it abuts said
30 annulus; and

e) securing said device by attaching said flange unit (50) to said annulus.

18. The method of claim 17, wherein said first flange (50) is reshapeable for a final shaping upon implantation.

5 19. The method of claim 18, wherein securing the device comprises suturing, clipping, or stapling said flange unit (50) to said annulus.

20. The method of any of claims 18-19, further comprising:
10 extending said flange portion of said sleeve (70) away from said first loop-shaped support (42) to form a flange overlapping a portion of said annulus and attaching said flange to said annulus.

15 21. The method of any of claims 18-20, wherein the device is inserted into the heart valve by using a catheter, whereupon the catheter is withdrawn leaving the device in said heart valve.

22. The method of any of claims 18-21, further comprising:
20 sealing said flange unit (50) against said annulus with a sealing surface of said flange unit (50) before securing the device.

23. The method of any of claims 18-22, wherein said first side
25 of the heart valve is the atrial side.

24. The method according to claim 23, further comprising reducing or preventing a backflow of blood from a ventricle side to said atrial side of said heart valve by said sealing.

25. A medical device for improving the function of a heart valve comprised of valve tissue including an annulus (18) and a plurality of leaflets (22, 24), the medical device comprising:
a first loop-shaped support (42), which is configured
5 to abut a first side of the heart valve, and
a fabric sleeve (70) at least partly covering said first loop-shaped support (42), and which sleeve (70) is sized to be folded over itself for forming at least a first flange (50), and the medical device being characterized in that said at
10 least a first flange (50) is given a final shaping upon implantation.

26. A medical device for improving the function of a heart valve comprised of valve tissue including an annulus (18) and a
15 plurality of leaflets (22, 24), the medical device comprising:
a first loop-shaped support (42), which is configured to abut a first side of the heart valve, and
a fabric sleeve (70) at least partly covering said first loop-shaped support (42), and which sleeve (70) is sized
20 to be folded over itself for forming at least a first flange (50), and the medical device being characterized in that at said first flange (50) is conformed to said annulus (18) before fixation of the device.

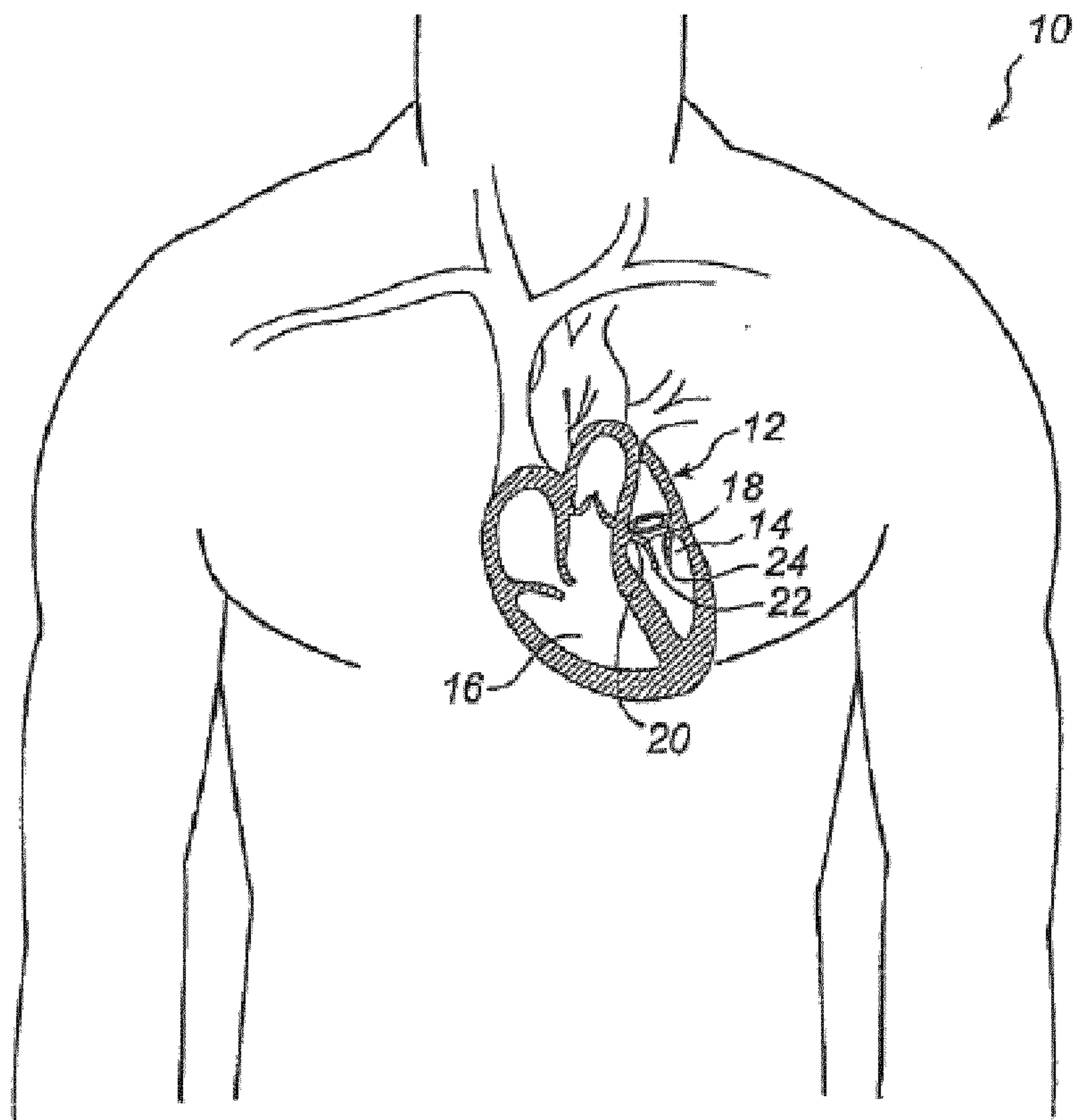

Fig. 1 a

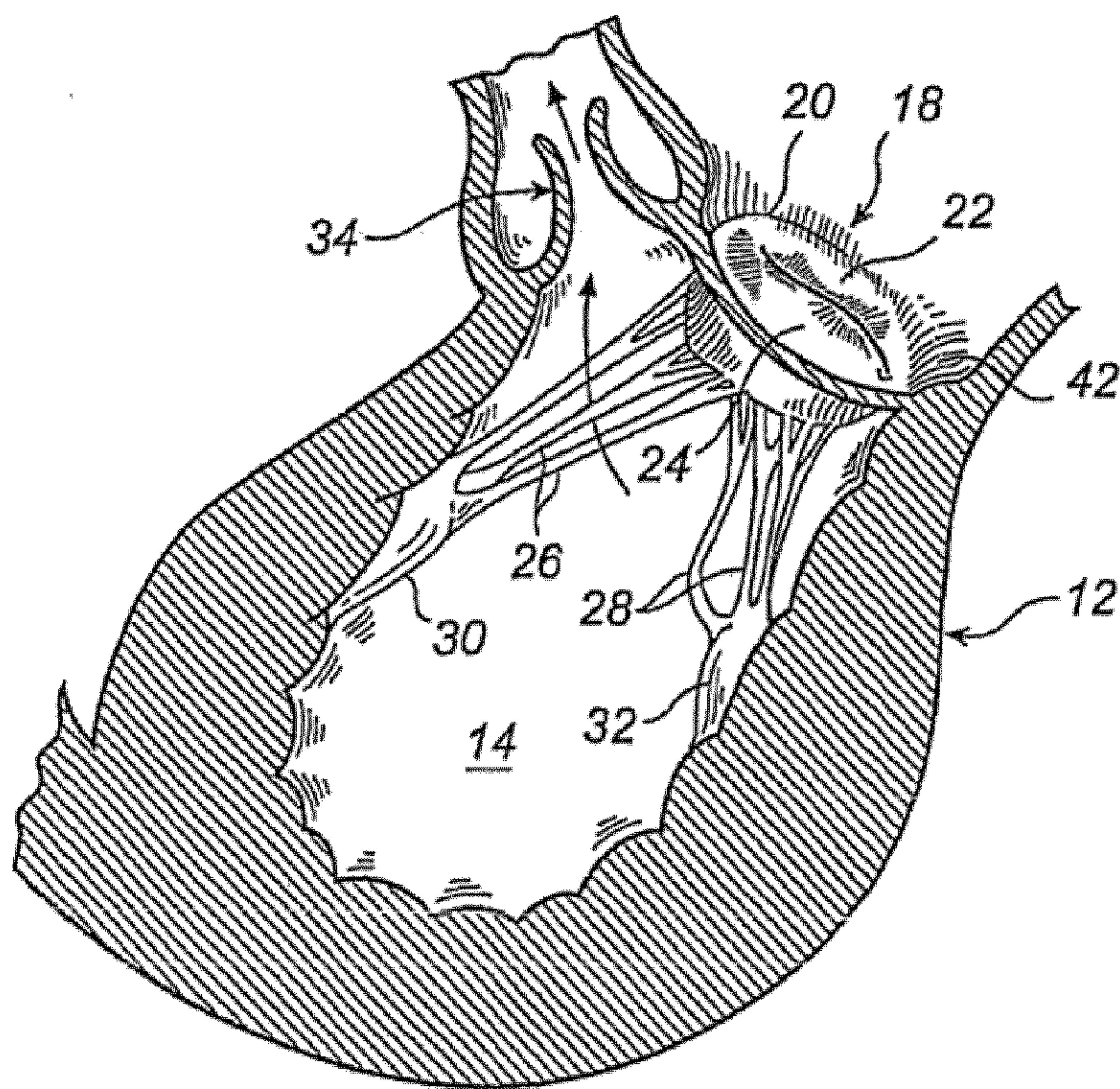

Fig. 1 b

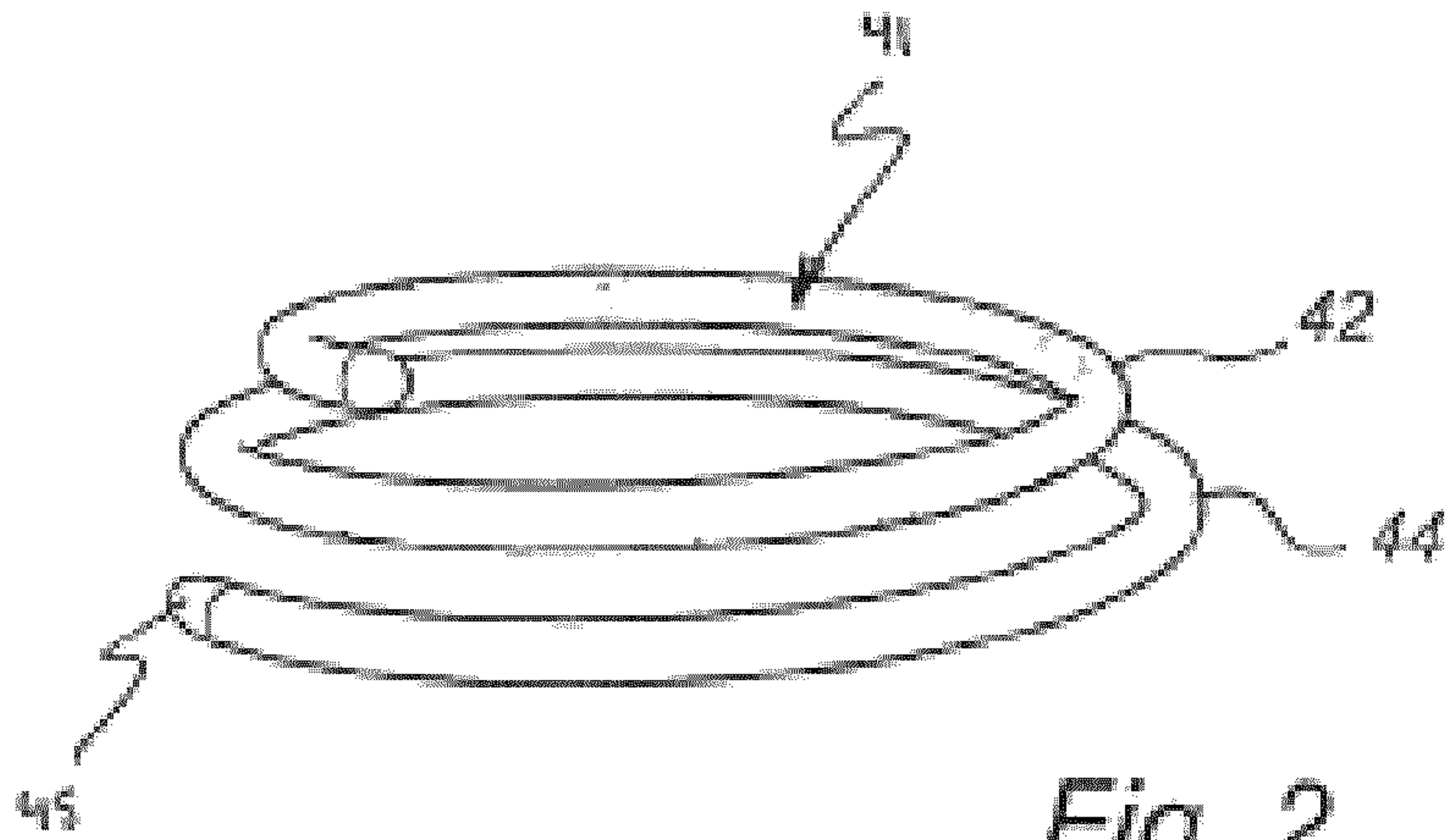

Fig. 2

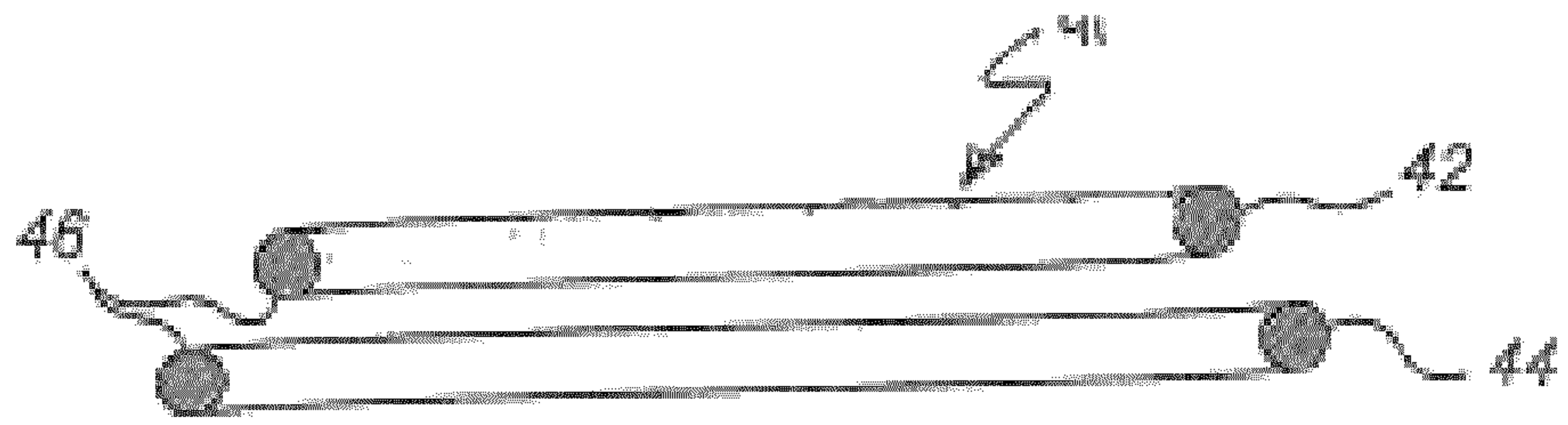

Fig. 3

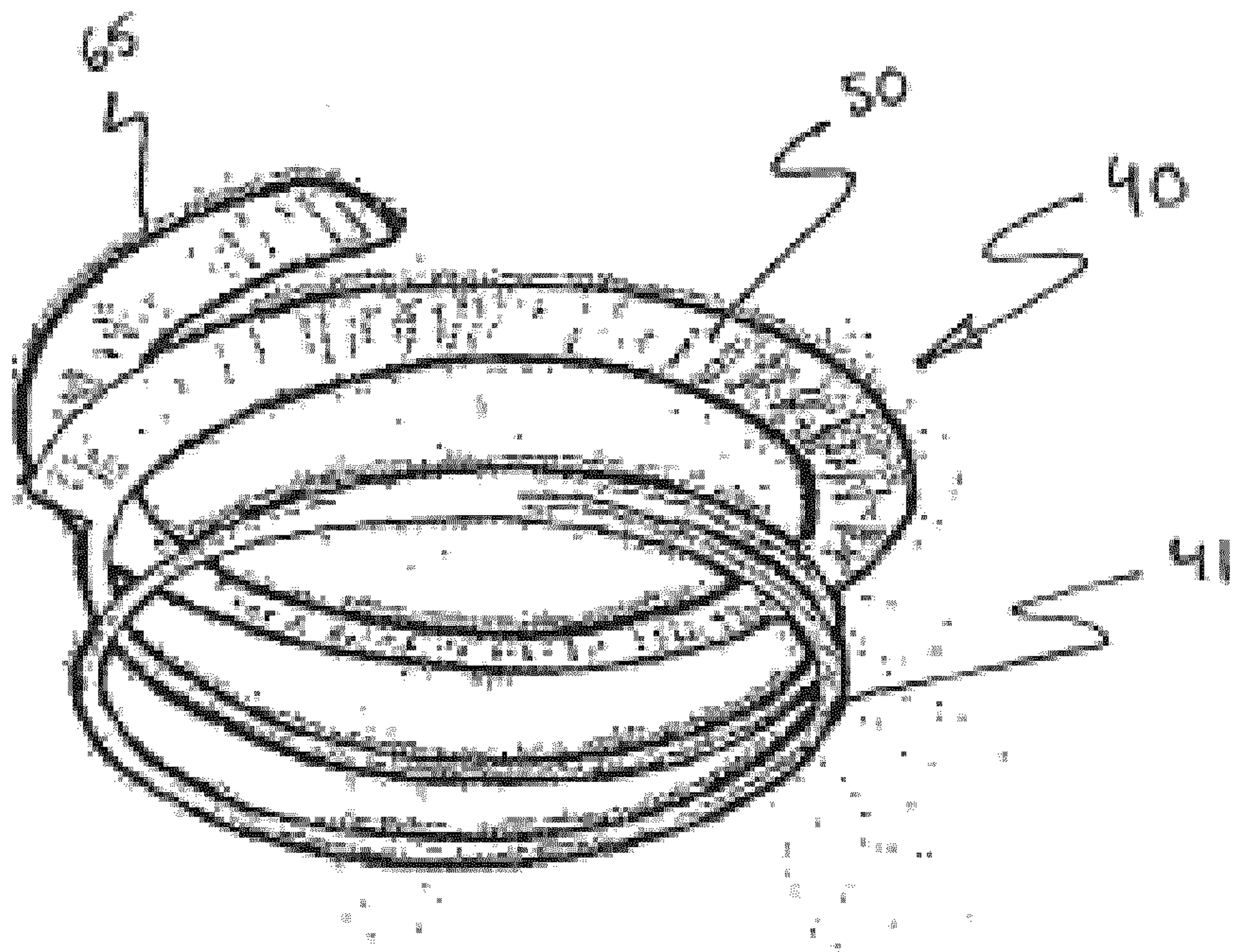

Fig. 4

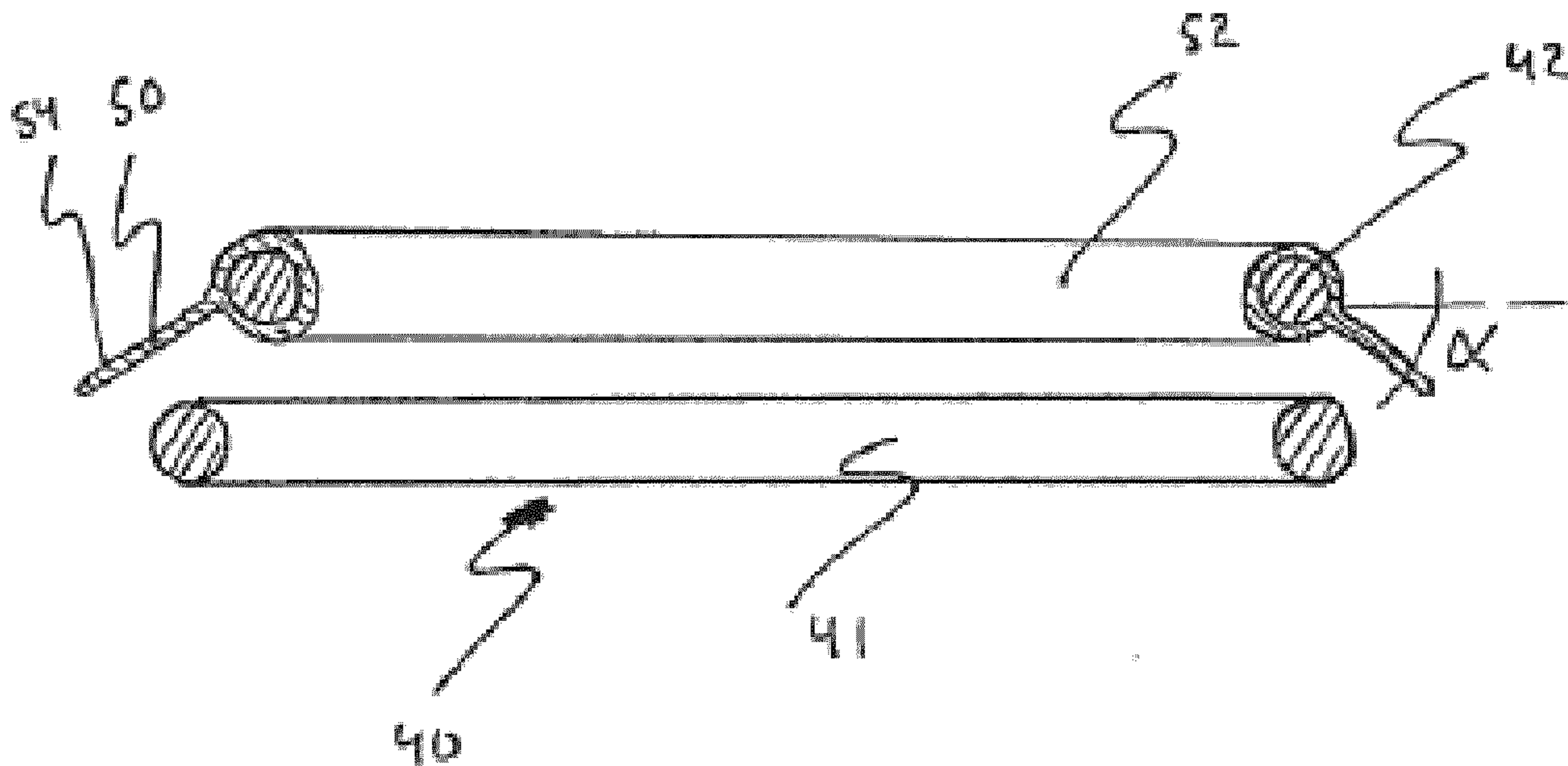

Fig. 5

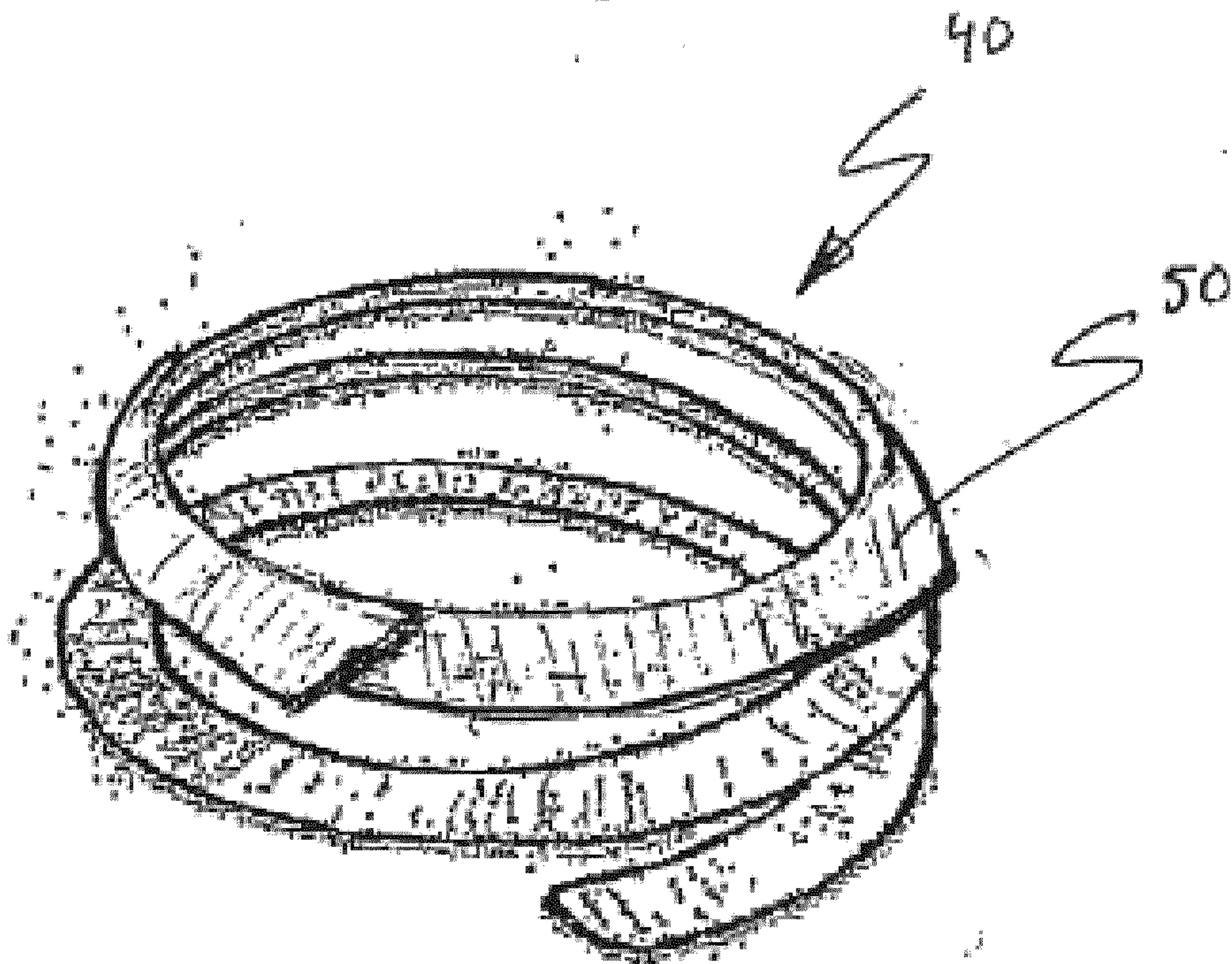

Fig. 6

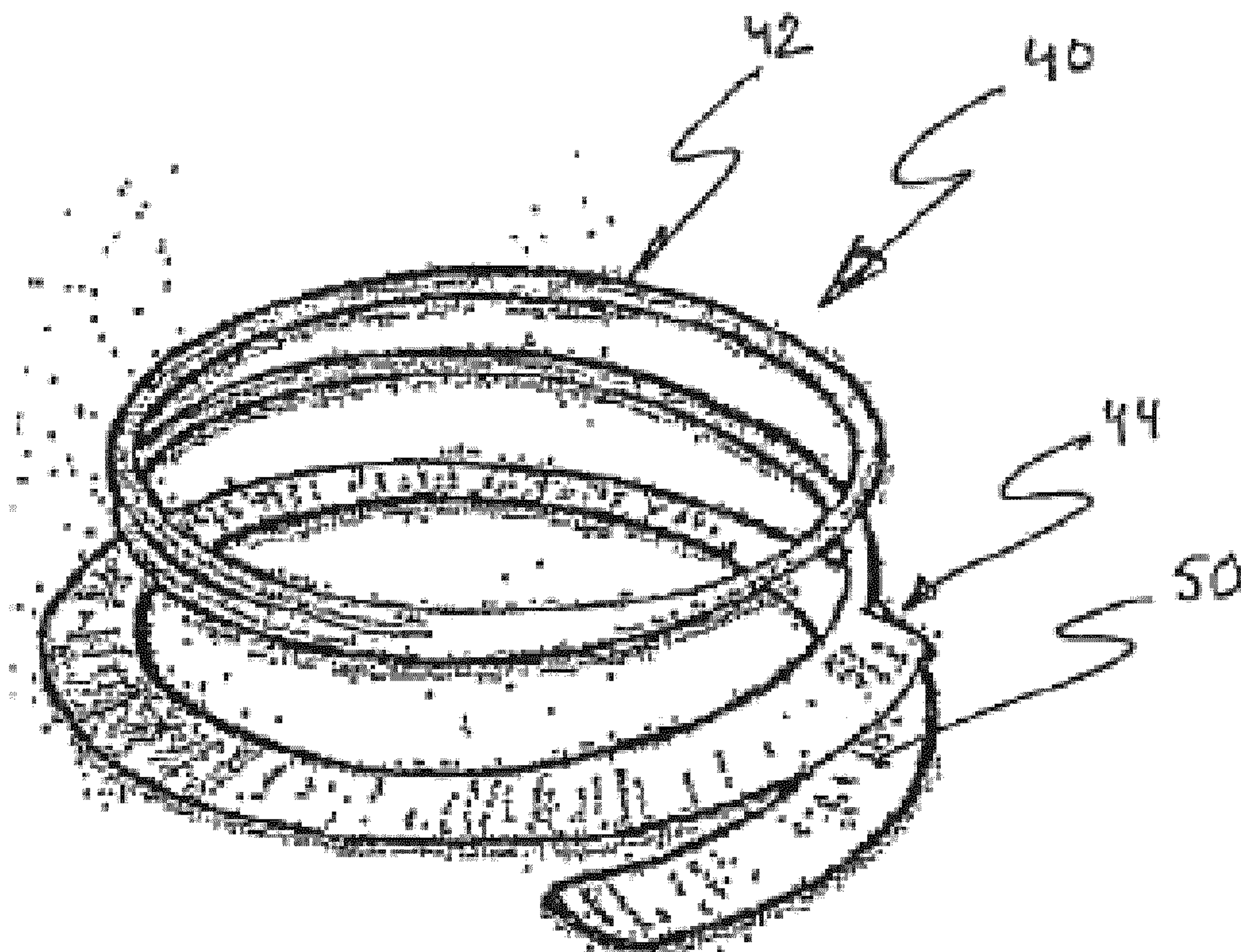

Fig. 7

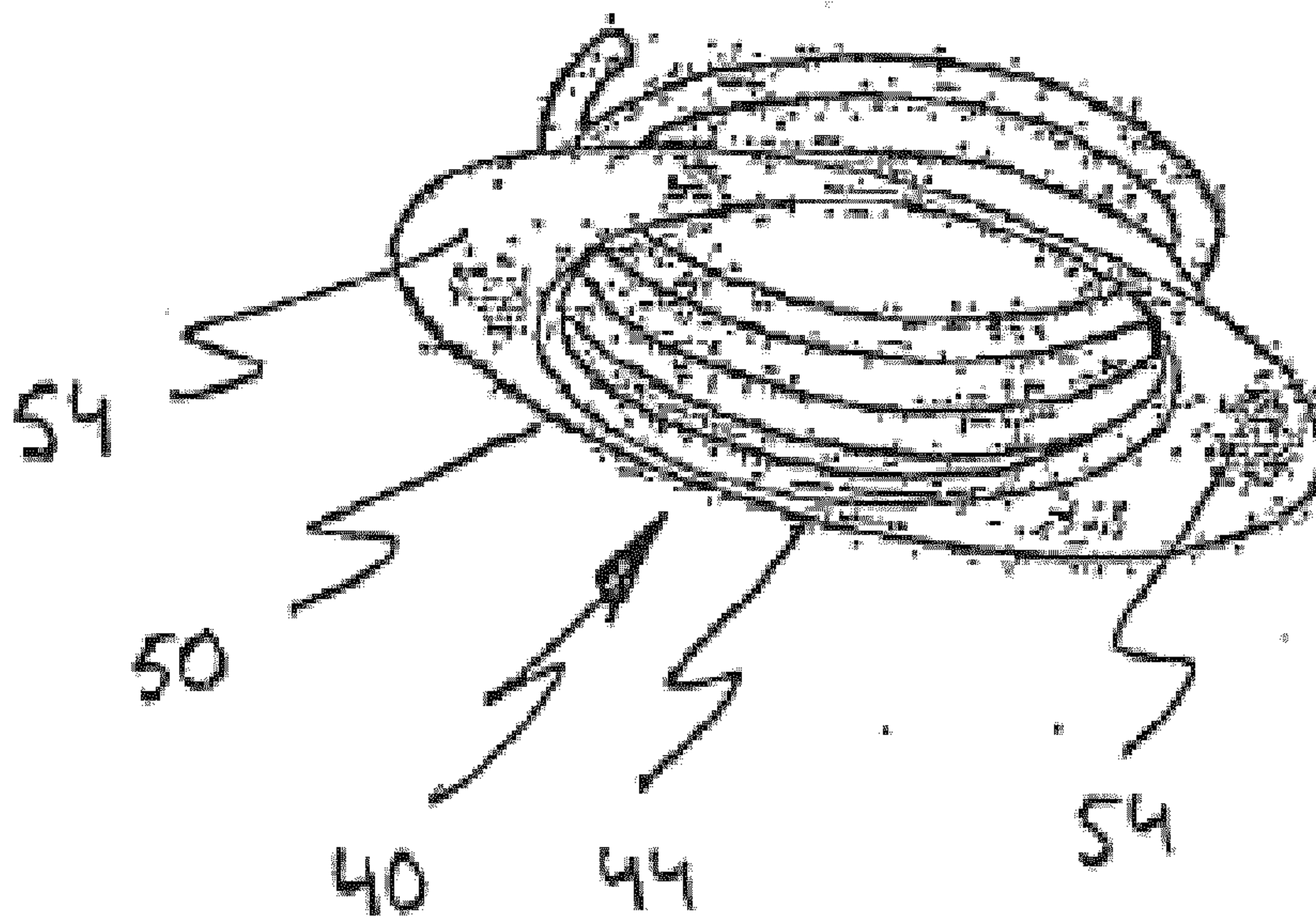

Fig. 8

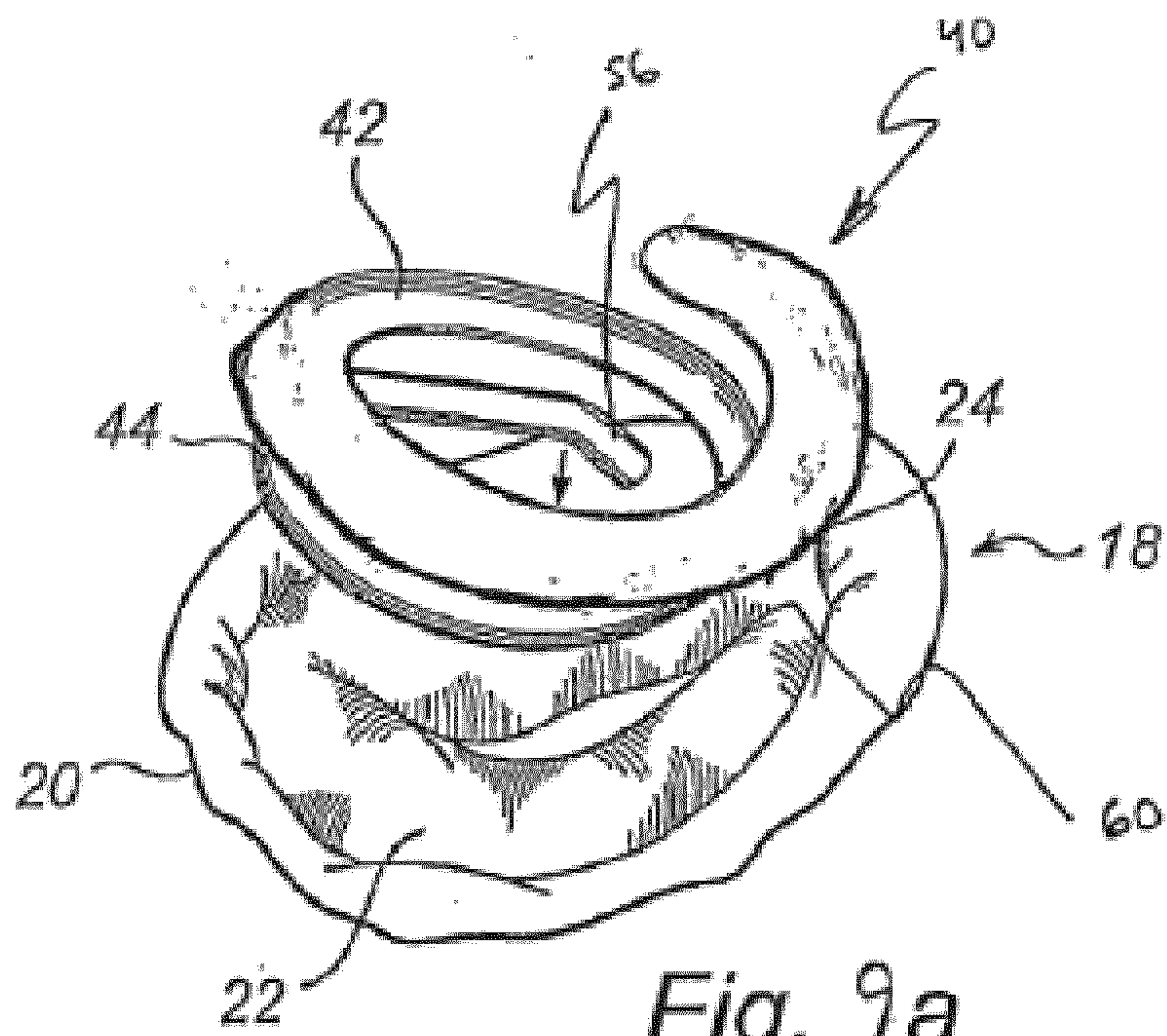

Fig. 9a

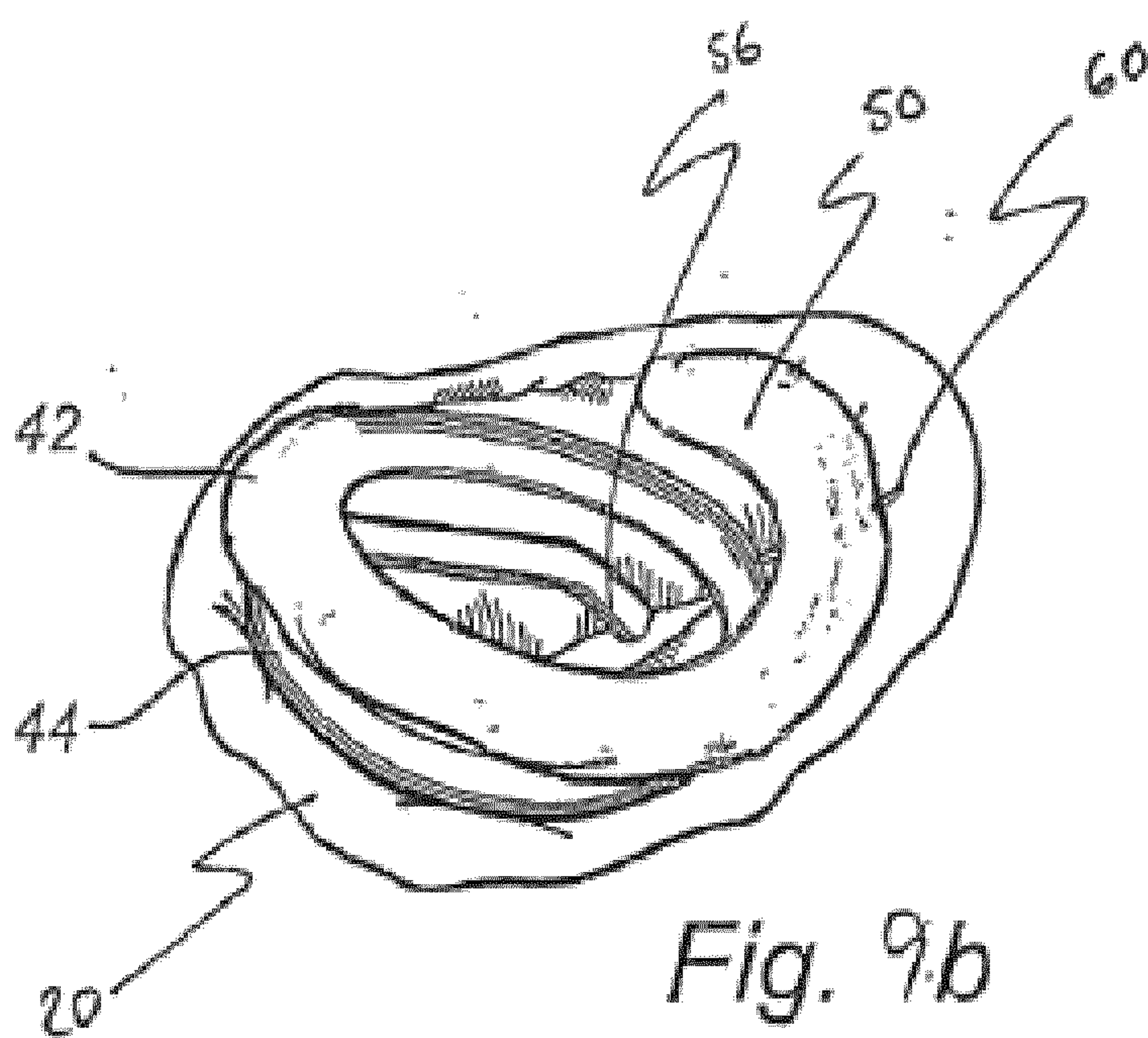

Fig. 9b

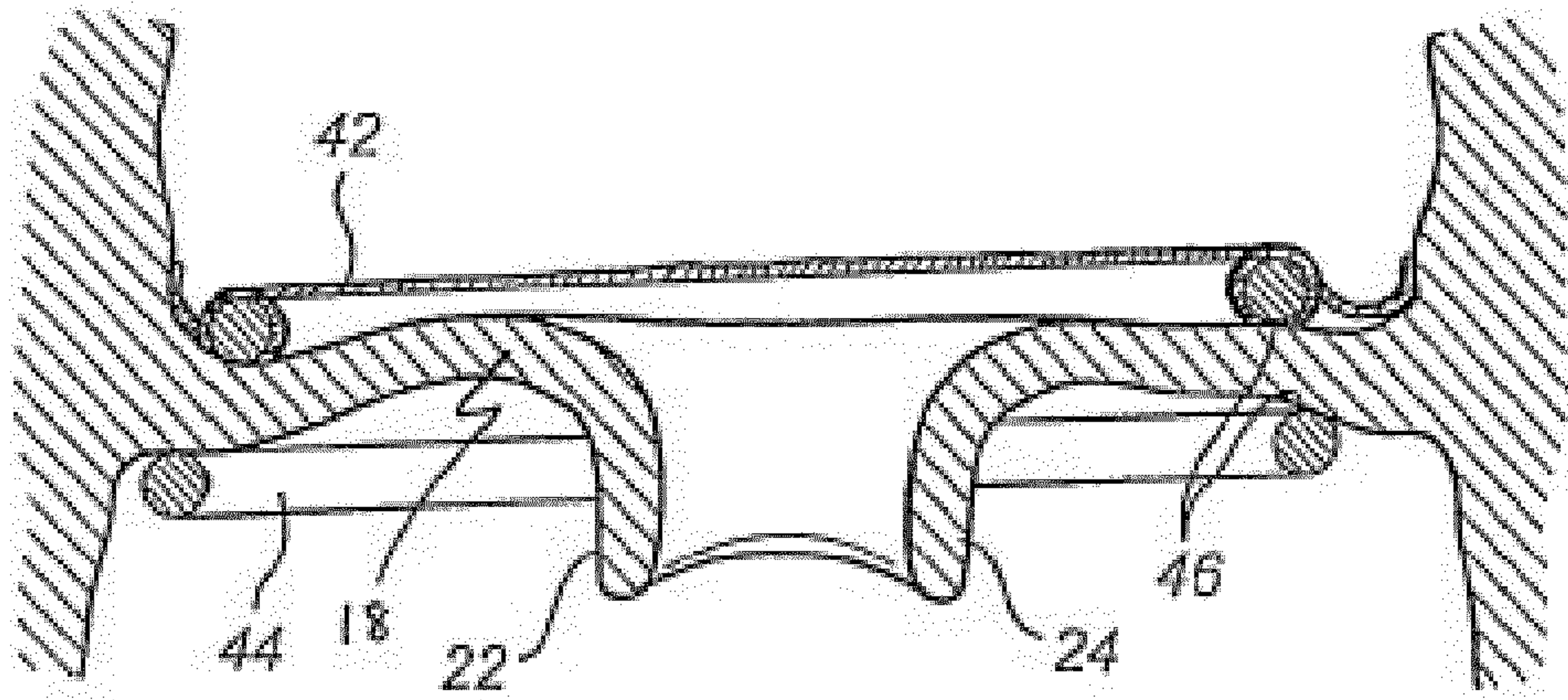

Fig. 10

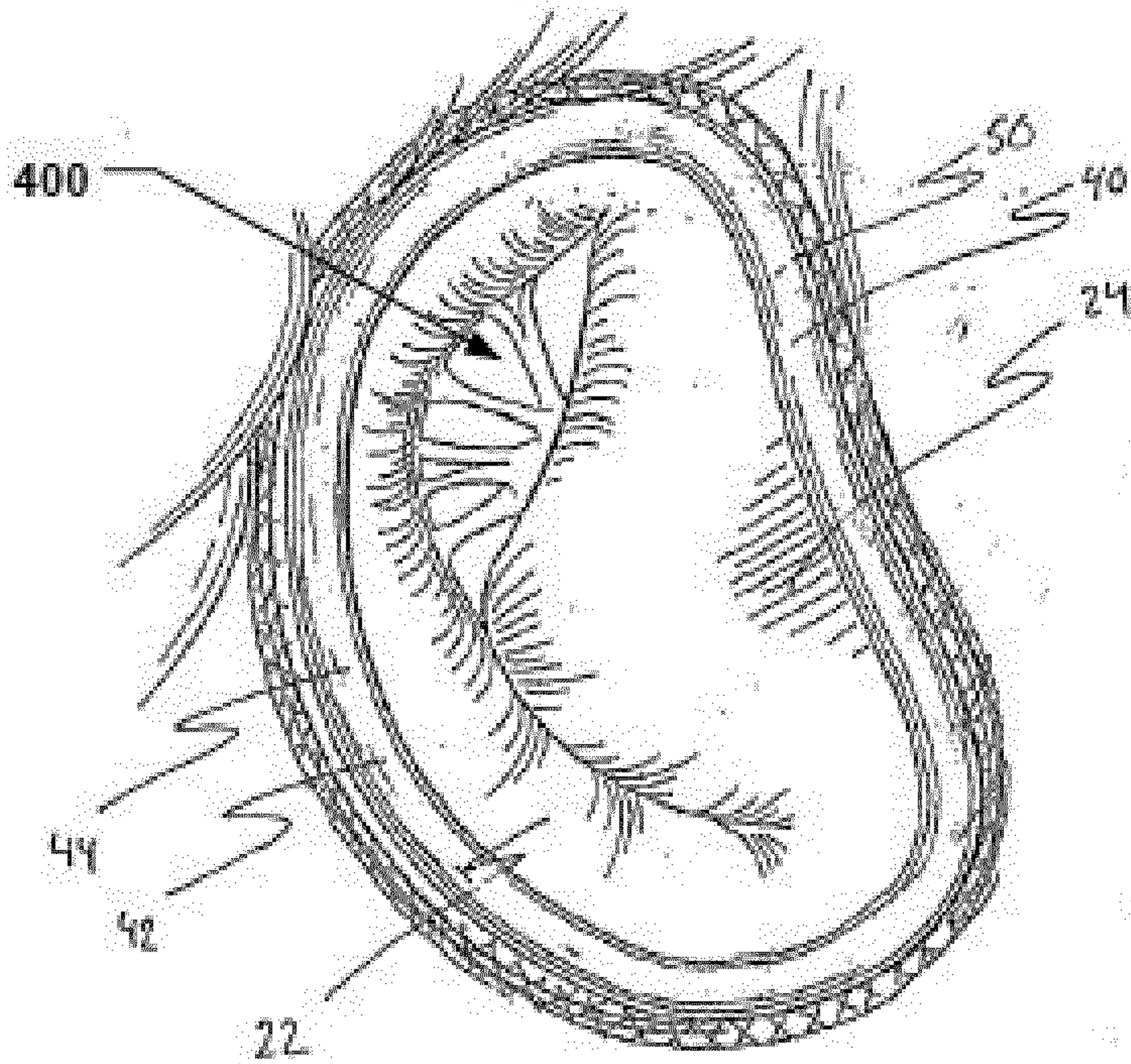

Fig. 11

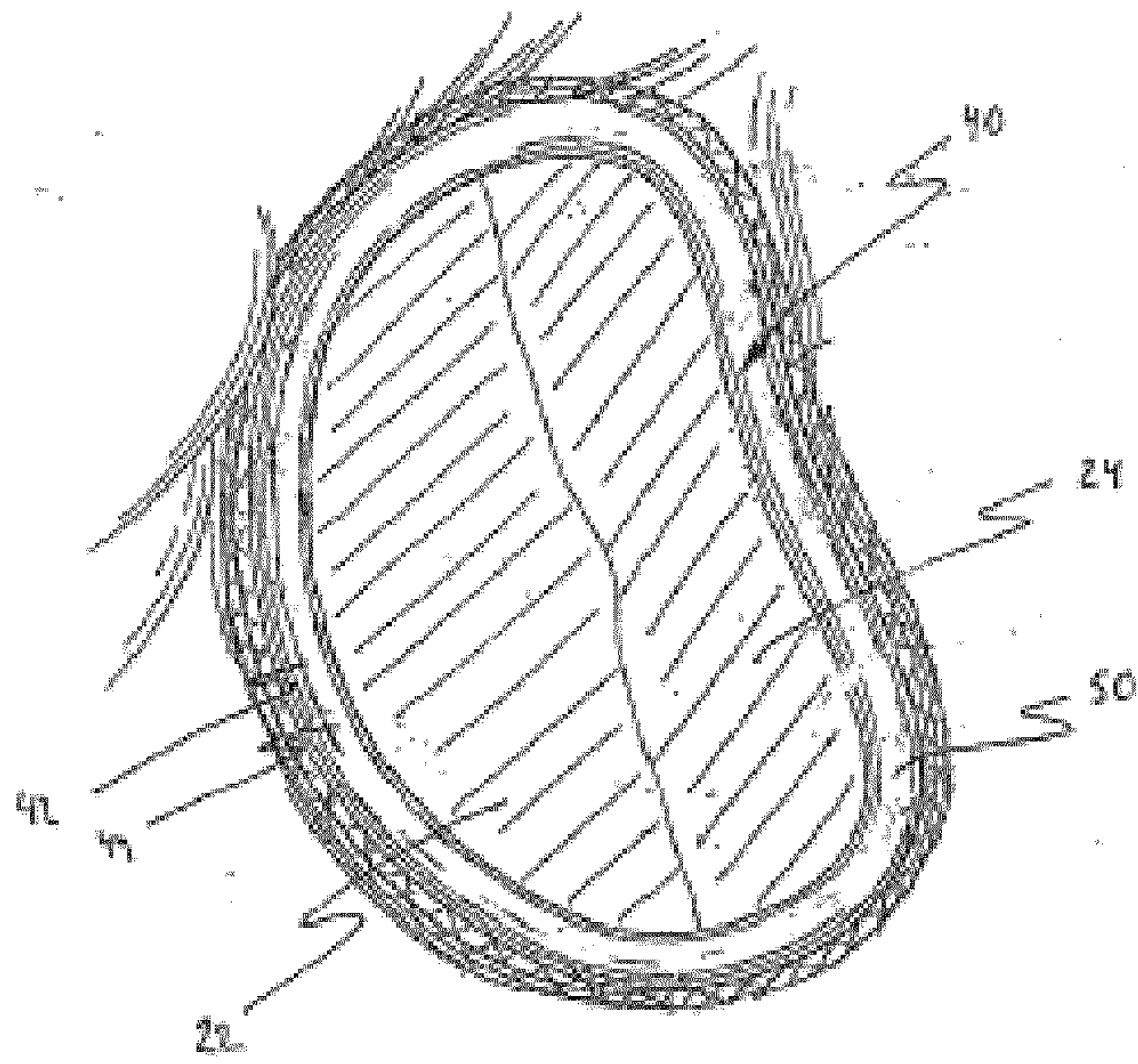

Fig. 12

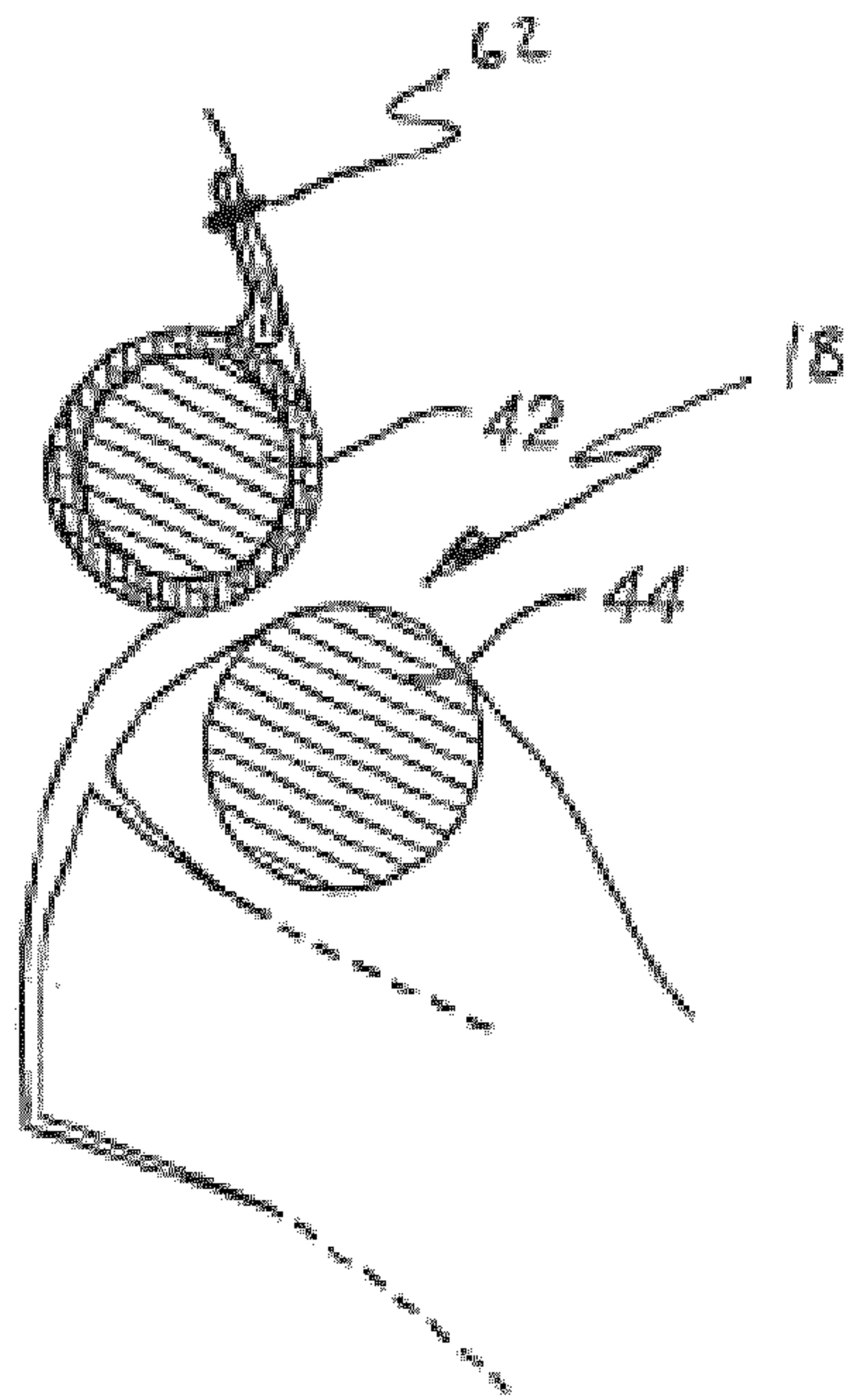

Fig. 13

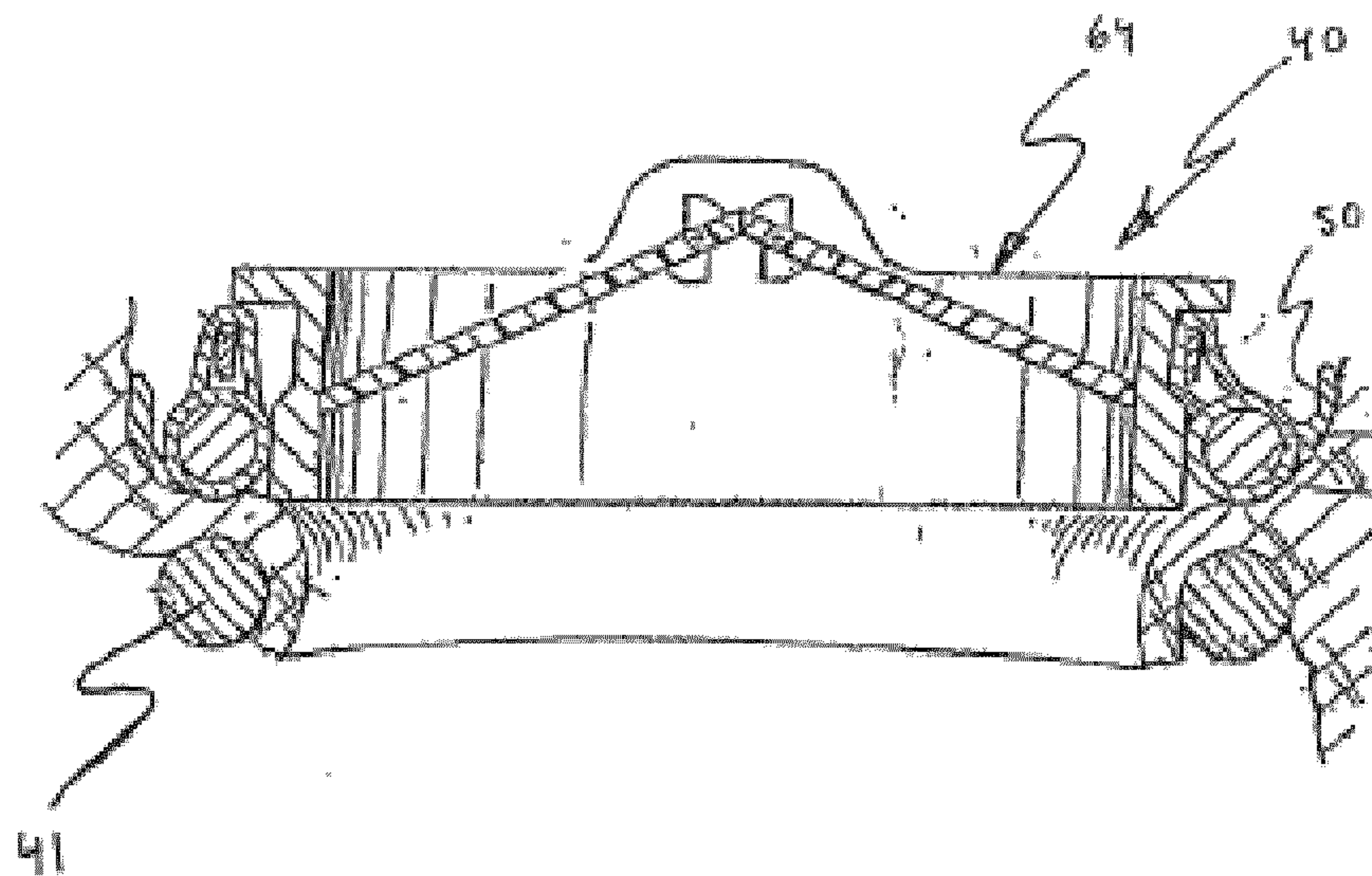

Fig. 14a

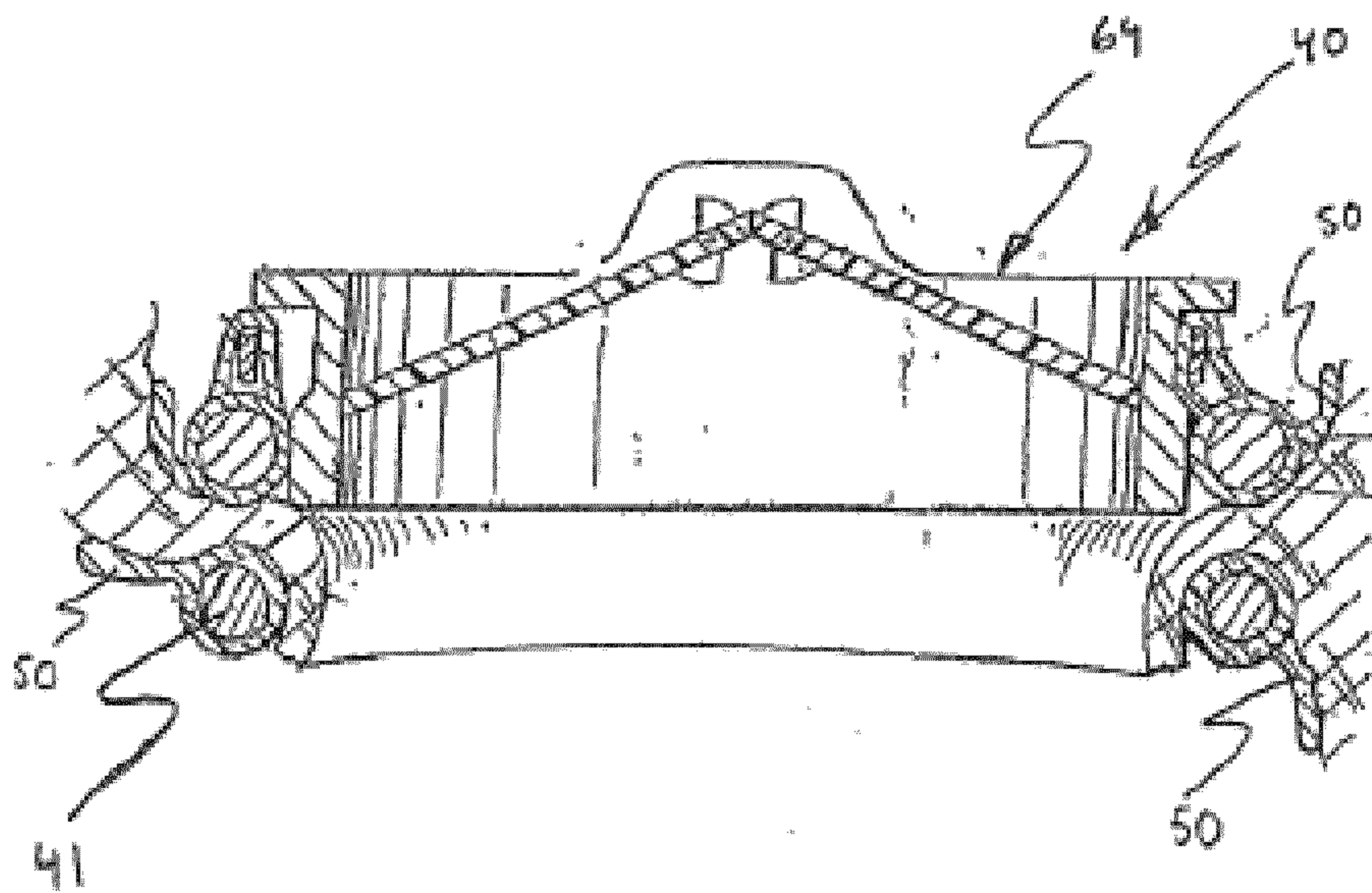

Fig. 14b

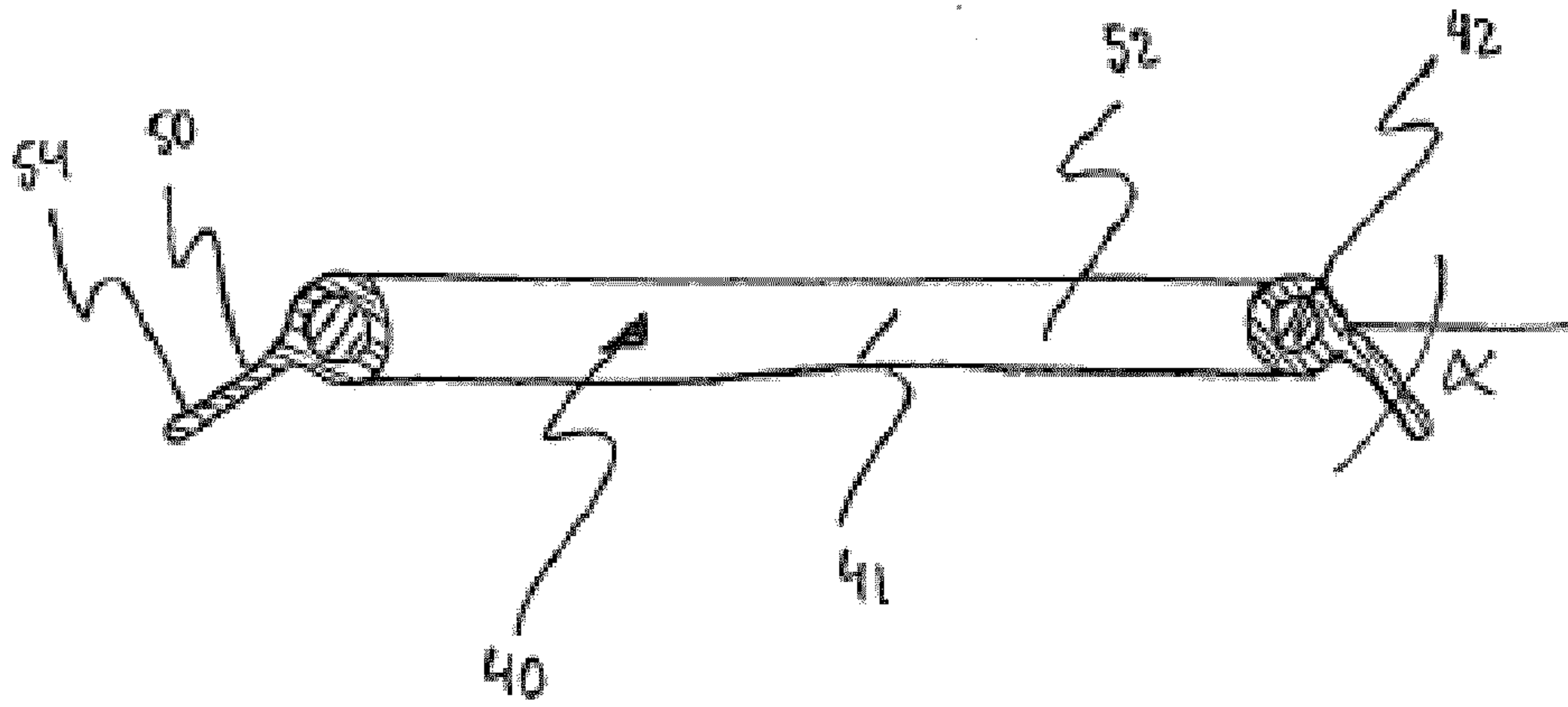

Fig. 15

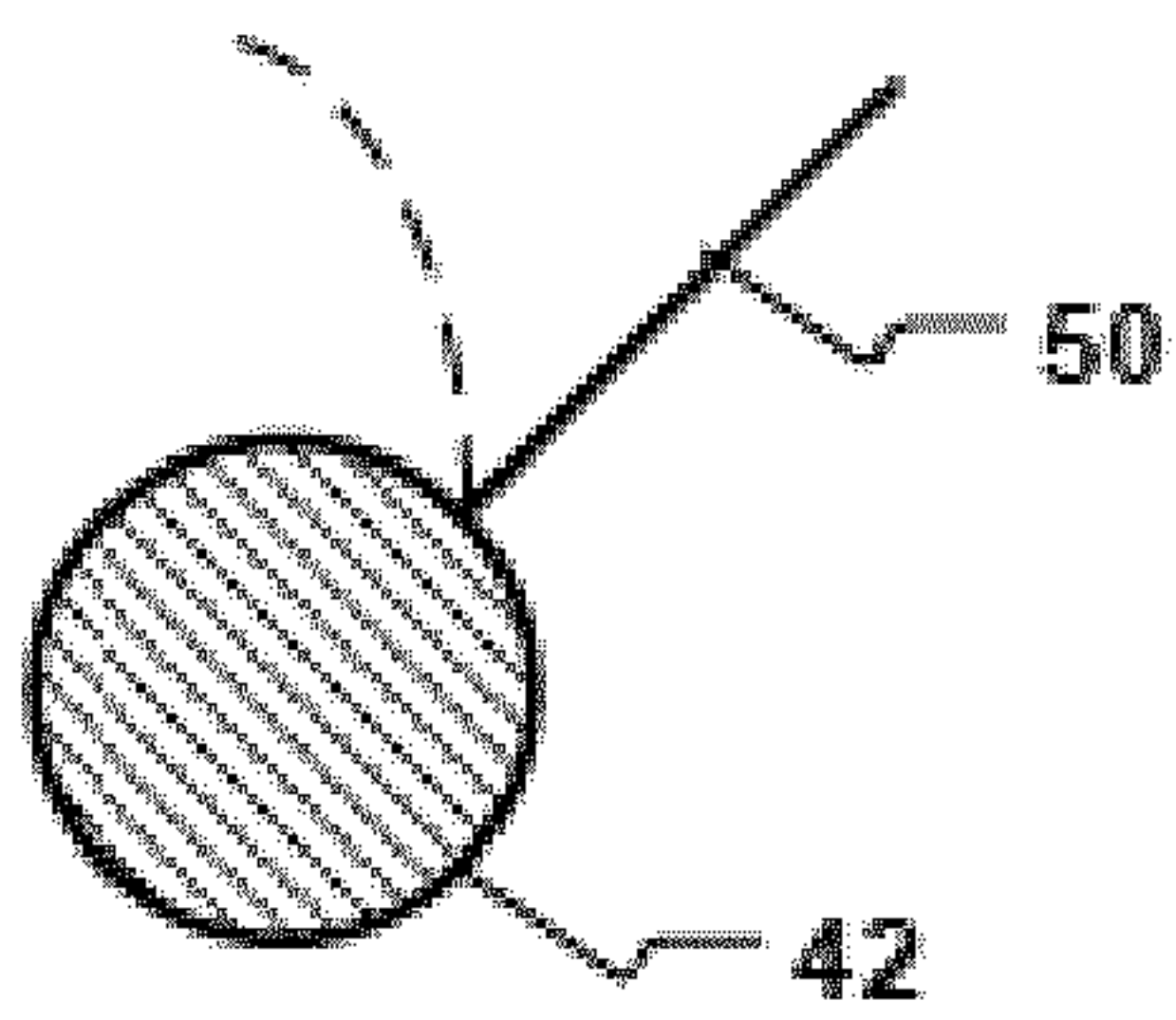

Fig. 16a

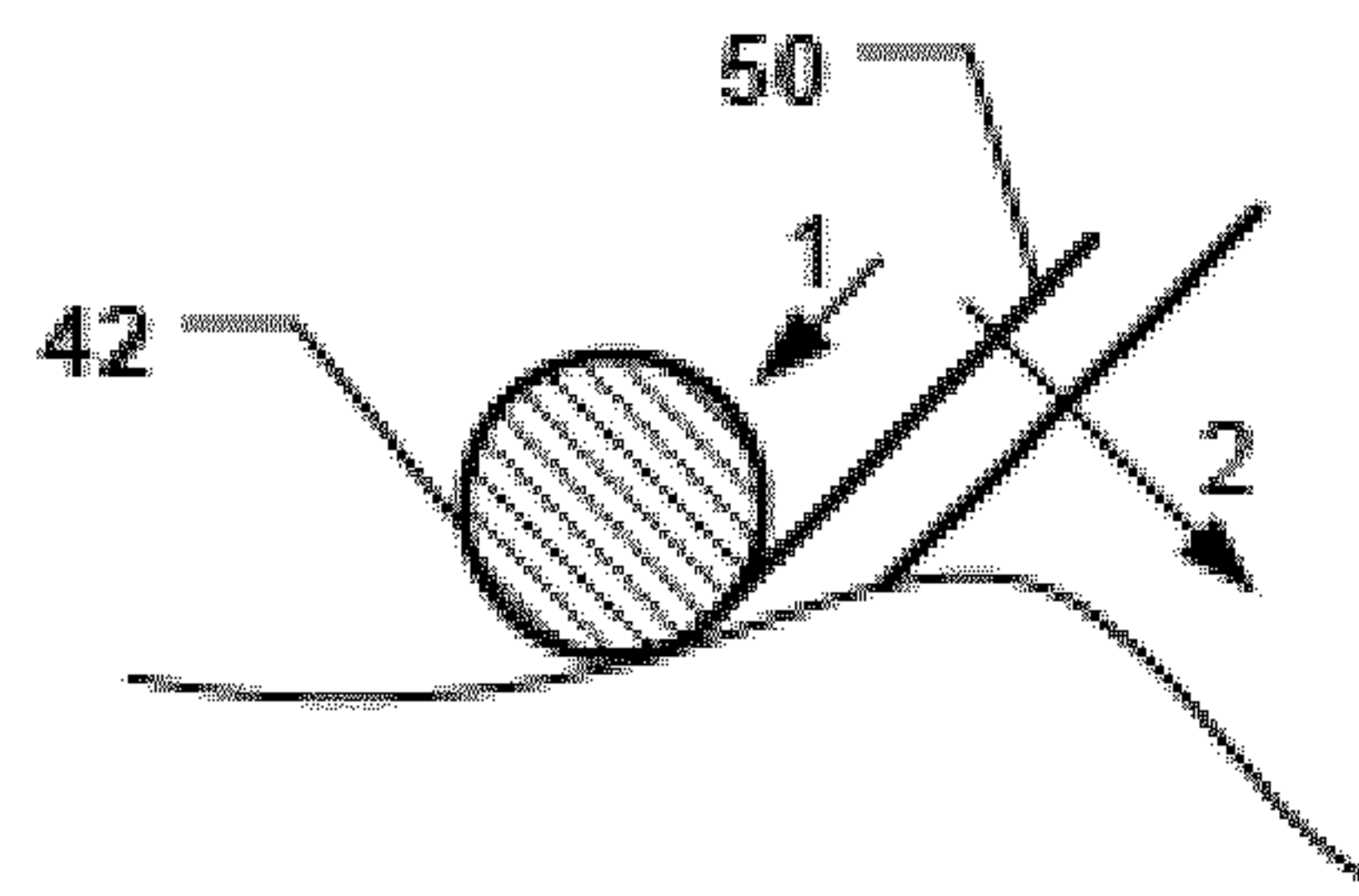

Fig. 16b

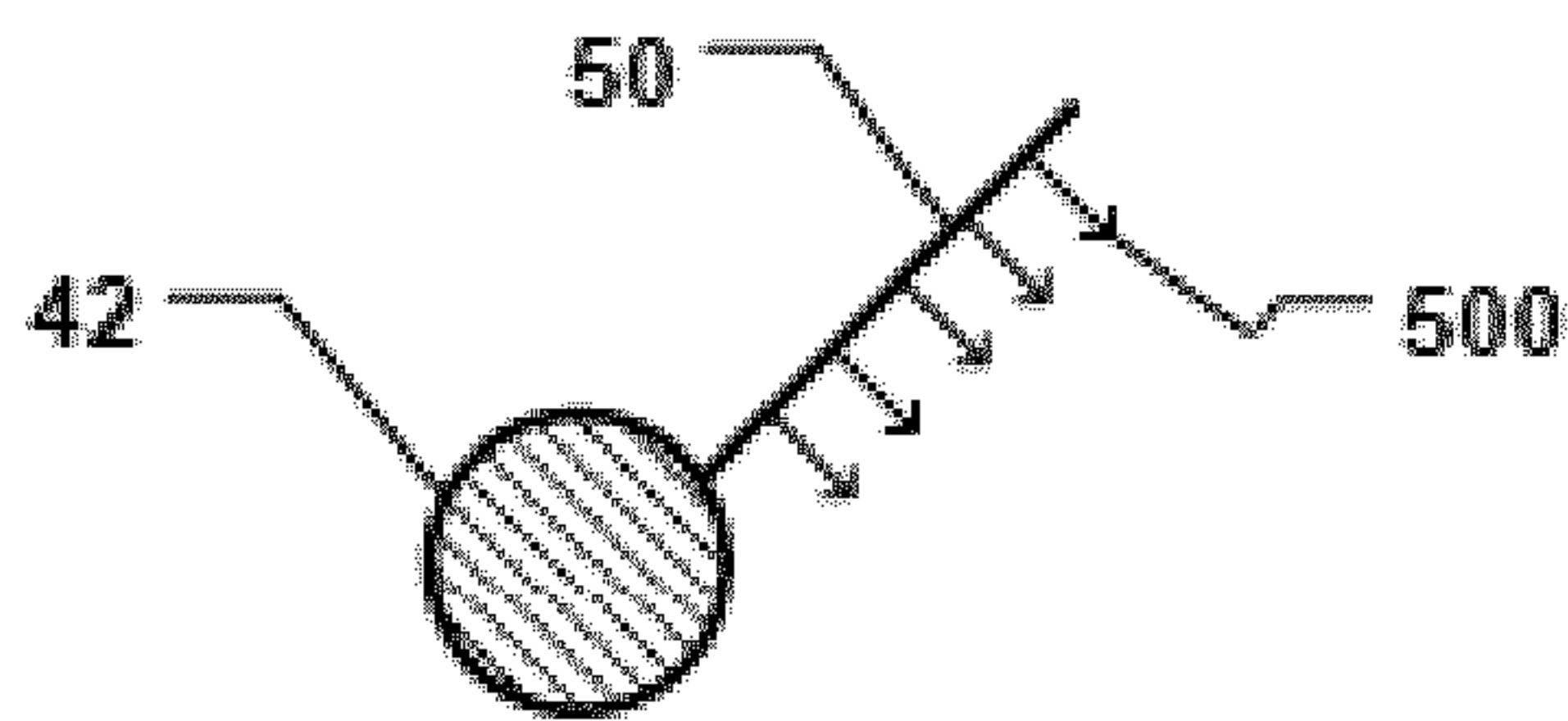

Fig. 17

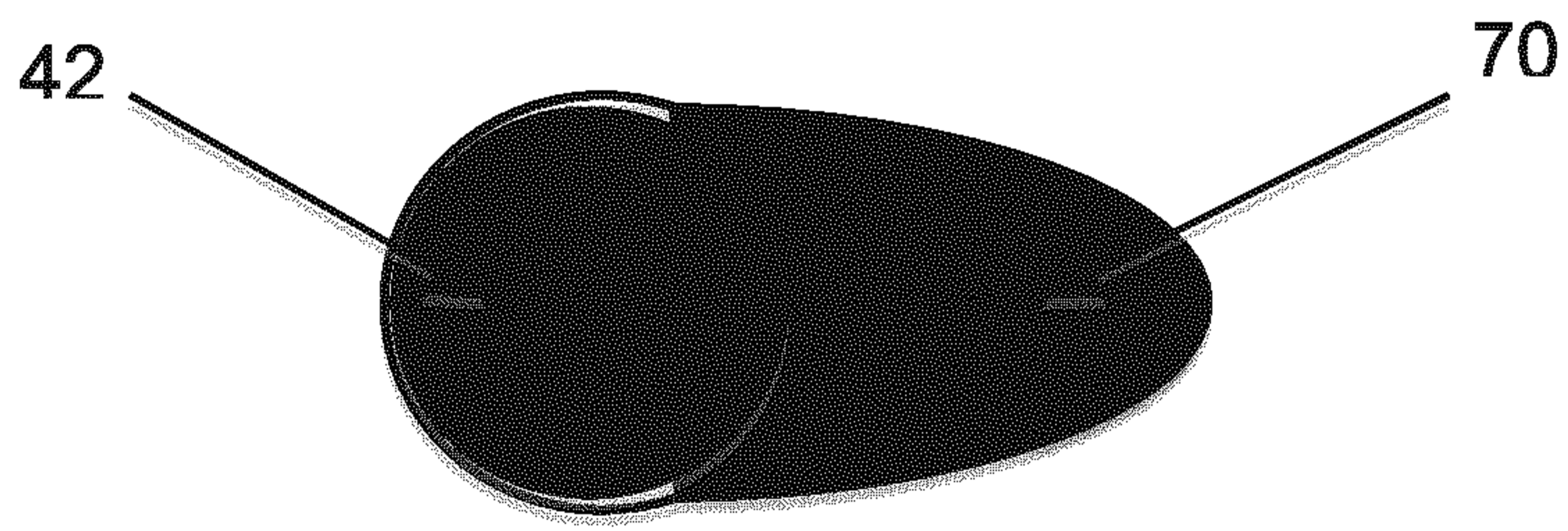

Fig. 18 a

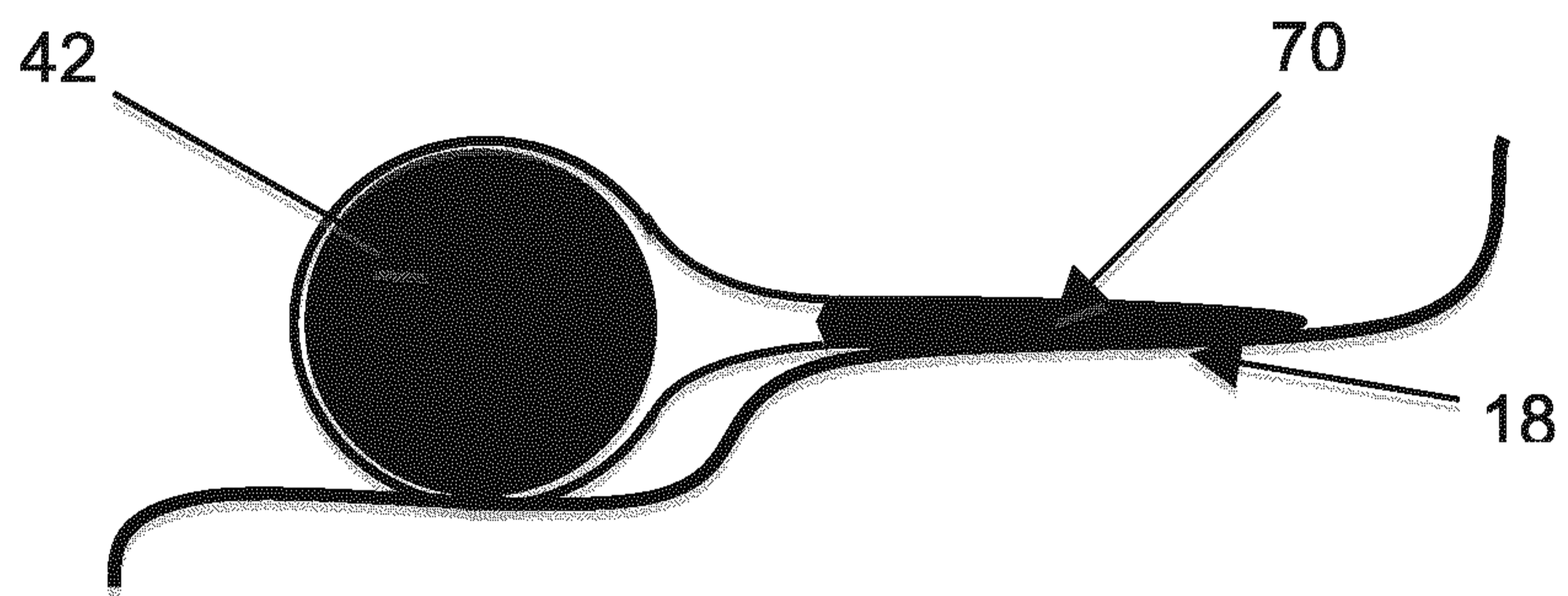

Fig. 18 b

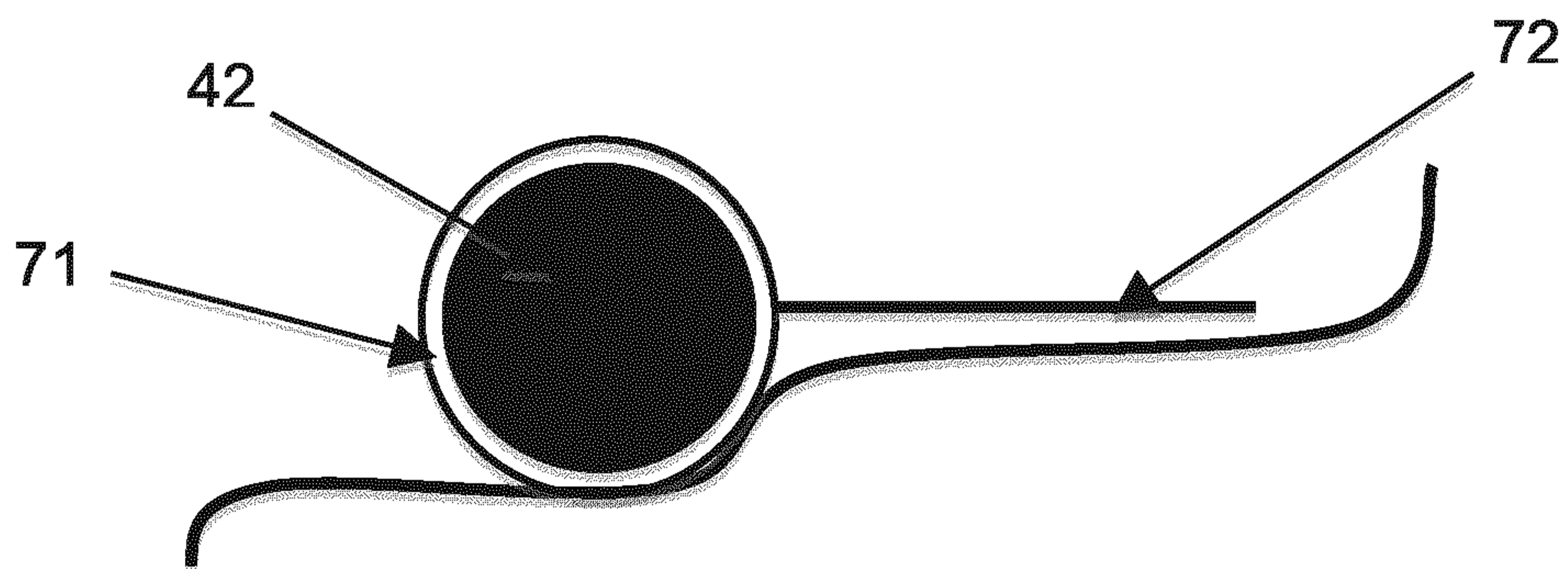

Fig. 18 c

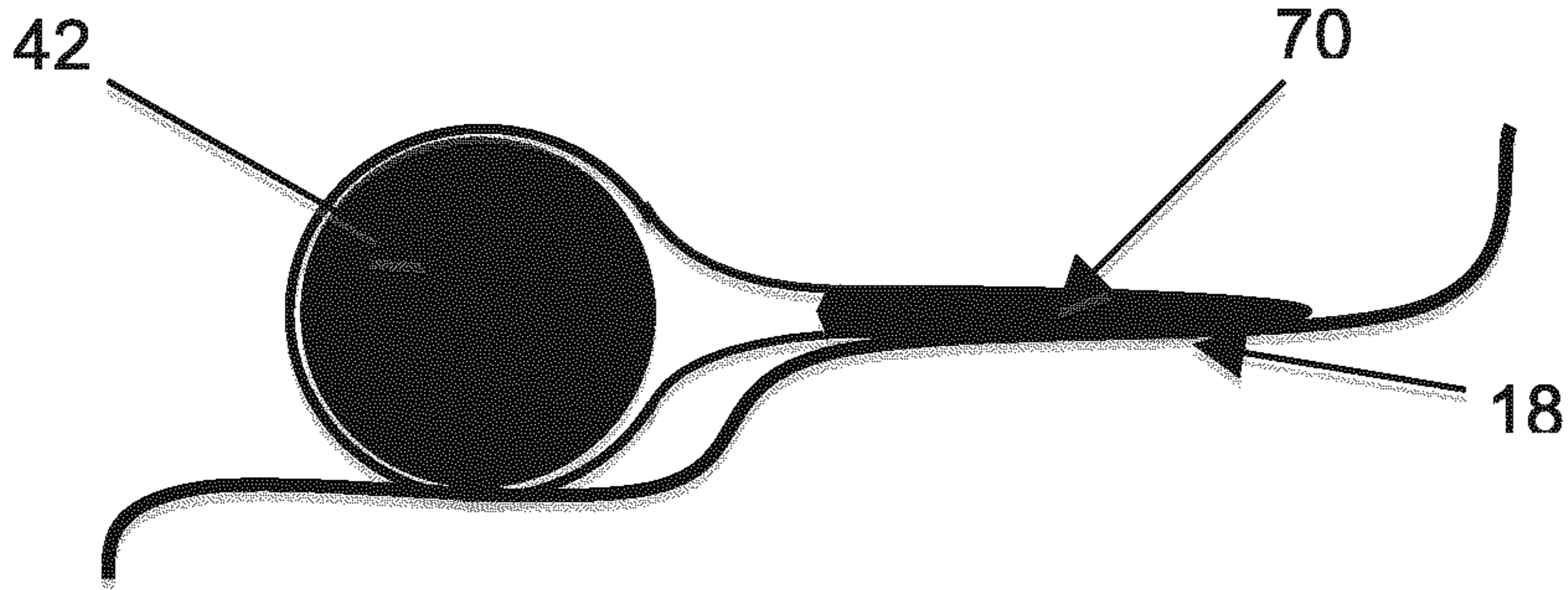

Fig. 18 b