

(12) STANDARD PATENT
(19) AUSTRALIAN PATENT OFFICE

(11) Application No. **AU 2005271005 B2**

(54) Title
Apparatus for dispensing beverages

(51) International Patent Classification(s)
B67D 1/08 (2006.01) **B67D 1/14** (2006.01)

(21) Application No: **2005271005** (22) Date of Filing: **2005.08.12**

(87) WIPO No: **WO06/016183**

(30) Priority Data

(31) Number (32) Date (33) Country
0418147.5 **2004.08.13** **GB**

(43) Publication Date: **2006.02.16**

(44) Accepted Journal Date: **2010.06.10**

(71) Applicant(s)
Scottish & Newcastle PLC.

(72) Inventor(s)
Robinson, Michael

(74) Agent / Attorney
FB Rice & Co, Level 23 44 Market Street, Sydney, NSW, 2000

(56) Related Art
GB 2327748 A
WO 2004/016545 A
AU 7904781 A

(19) World Intellectual Property Organization
International Bureau



(43) International Publication Date
16 February 2006 (16.02.2006)

PCT

(10) International Publication Number
WO 2006/016183 A1

(51) International Patent Classification⁷: **B67D 1/08**,
F28F 27/02, F28D 7/02, B67D 1/14

(21) International Application Number:
PCT/GB2005/003180

(22) International Filing Date: 12 August 2005 (12.08.2005)

(25) Filing Language: English

(26) Publication Language: English

(30) Priority Data:
0418147.5 13 August 2004 (13.08.2004) GB

(71) Applicant (for all designated States except US): **SCOTTISH & NEWCASTLE PLC.** [GB/GB]; 33 Ellersly Road, Edinburgh EH12 6HX (GB).

(72) Inventor; and

(75) Inventor/Applicant (for US only): **ROBINSON, Michael** [GB/GB]; Northside Farm, Sunnyside, Krook, Bishop Auckland, County Durham DL13 4LT (GB).

(74) Agents: **ALEXANDER, Thomas, Bruce** et al.; Boulton Wade Tennant, Verulam Gardens, 70 Gray's Inn Road, London WC1X 8BT (GB).

(81) Designated States (unless otherwise indicated, for every kind of national protection available): AE, AG, AL, AM,

AT, AU, AZ, BA, BB, BG, BR, BW, BY, BZ, CA, CH, CN, CO, CR, CU, CZ, DE, DK, DM, DZ, EC, EE, EG, ES, FI, GB, GD, GE, GH, GM, HR, HU, ID, IL, IN, IS, JP, KE, KG, KM, KP, KR, KZ, LC, LK, LR, LS, LT, LU, LV, MA, MD, MG, MK, MN, MW, MX, MZ, NA, NG, NI, NO, NZ, OM, PG, PH, PL, PT, RO, RU, SC, SD, SE, SG, SK, SL, SM, SY, TJ, TM, TN, TR, TT, TZ, UA, UG, US, UZ, VC, VN, YU, ZA, ZM, ZW.

(84) Designated States (unless otherwise indicated, for every kind of regional protection available): ARIPO (BW, GH, GM, KE, LS, MW, MZ, NA, SD, SL, SZ, TZ, UG, ZM, ZW), Eurasian (AM, AZ, BY, KG, KZ, MD, RU, TJ, TM), European (AT, BE, BG, CH, CY, CZ, DE, DK, EE, ES, FI, FR, GB, GR, HU, IE, IS, IT, LT, LU, LV, MC, NL, PL, PT, RO, SE, SI, SK, TR), OAPI (BF, BJ, CF, CG, CI, CM, GA, GN, GQ, GW, ML, MR, NE, SN, TD, TG).

Declarations under Rule 4.17:

— as to applicant's entitlement to apply for and be granted a patent (Rule 4.17(ii)) for the following designations AE, AG, AL, AM, AT, AU, AZ, BA, BB, BG, BR, BW, BY, BZ, CA, CH, CN, CO, CR, CU, CZ, DE, DK, DM, DZ, EC, EE, EG, ES, FI, GB, GD, GE, GH, GM, HR, HU, ID, IL, IN, IS, JP, KE, KG, KM, KP, KR, KZ, LC, LK, LR, LS, LT, LU, LV, MA, MD, MG, MK, MN, MW, MX, MZ, NA, NG, NI, NO, NZ, OM, PG, PH, PL, PT, RO, RU, SC, SD, SE, SG,

[Continued on next page]

(54) Title: COOLED BEVERAGE DISPENSER WITH A PYTHON AND AN ADDITIONAL CHILLER

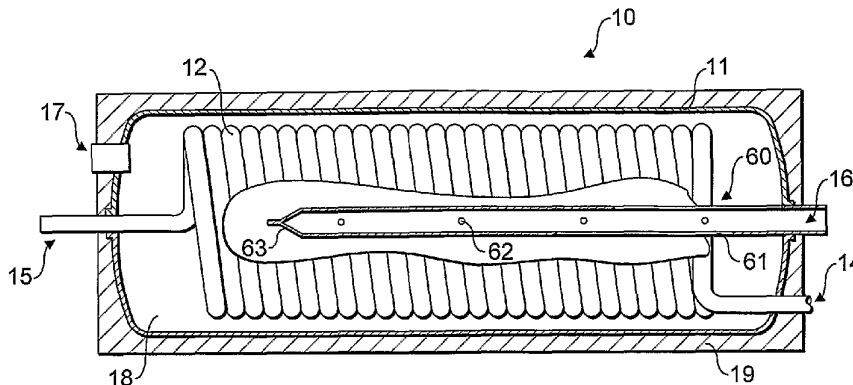

(57) Abstract: Apparatus for cooling draft beverages comprising: a beverage line (3, 33); a dispensation font (1) located at a dispensation site, the dispensation font comprising one or more taps (2); the beverage line extending to the dispensation font for transporting beverage to the one or more taps; the beverage line running to the dispensation site within a python (20); wherein the python comprises one or more cooling lines (21, 22) for transporting a cooling medium to and from the dispensation site. Wherein a cooling pod (10) is provided at the dispensation site. The cooling pod comprises a cooling chamber (18) through which the beverage line passes, the cooling chamber comprising an inlet (16) connected to the cooling line of the python for receiving the cooling medium and an outlet (17) connected to the cooling line of the python for discharging cooling medium back to the python. The cooling pod further comprises a cooling pipe connected to the inlet of the cooling chamber and comprising a plurality of apertures (62) through which, in use, the cooling medium passes into the cooling chamber in the form of a spray.



WO 2006/016183 A1



SK, SL, SM, SY, TJ, TM, TN, TR, TT, TZ, UA, UG, UZ, VC, VN, YU, ZA, ZM, ZW, ARIPO patent (BW, GH, GM, KE, LS, MW, MZ, NA, SD, SL, SZ, TZ, UG, ZM, ZW), Eurasian patent (AM, AZ, BY, KG, KZ, MD, RU, TJ, TM), European patent (AT, BE, BG, CH, CY, CZ, DE, DK, EE, ES, FI, FR, GB, GR, HU, IE, IS, IT, LT, LU, LV, MC, NL, PL, PT, RO, SE, SI, SK, TR), OAPI patent (BF, BJ, CF, CG, CI, CM, GA, GN, GQ, GW, ML, MR, NE, SN, TD, TG)

— of inventorship (Rule 4.17(iv)) for US only

Published:

— with international search report

For two-letter codes and other abbreviations, refer to the "Guidance Notes on Codes and Abbreviations" appearing at the beginning of each regular issue of the PCT Gazette.

APPARATUS FOR DISPENSING BEVERAGES

The present invention relates to apparatus for dispensing beverages. In particular, to apparatus useful
5 for dispensing beverages at low temperatures.

Many beverages, including beers, lagers, soft drinks, milk shakes, wines and spirits are beneficially served at low temperatures. If the temperature of the beverage is too high, the quality and taste of the beverage may be
10 affected adversely. In addition, recent consumer trends have increased the demand for beverages to be served at lower temperatures of, for example, around 3 degrees Celsius. In order to meet consumer expectations, it is desirable to dispense beverages at consistent
15 temperatures. A particular problem has been found in dispensing draft beverages at low and consistent temperatures. By draft beverages is meant beverages which are stored at a point remote from the point of dispensation and transferred on demand to the point of
20 dispensation through a beverage line. Typically the transfer is achieved using pumping mechanisms. For instance, it is common in public houses and bars for beverages to be stored in a cellar or a separate room and transferred to the bar area where dispensation occurs
25 using a mechanical pump or gas pressurised system. There are particular problems in dispensing beverages in these conditions. Firstly, the length of the beverage lines between the cellar and the dispensation site may be many metres and there is a tendency for beverage in the
30 beverage lines to increase in temperature during transit. Attempts have been made to overcome this problem.

It has previously been attempted to solve this problem by providing a cooler in the cellar to cool the beverage at

- 2 -

the remote location and then transport the beverage in an insulated and cooled conduit known as a "python" to the dispensation site. The python comprises one or more beverage lines running in parallel with a cooling circuit comprising one or more cooling lines through which cooling water flows. The cooling water is typically supplied by the cooler. The cooling circuit comprises an outward leg flowing from the cooler to the dispensation site and a return leg flowing from the dispensation site to the cooler. A problem found with this attempted solution is that variation in the temperature of the beverage when it reaches the dispensation site can still occur due to changes in demand on the separate beverage flow lines and in particular occurs where beverage is left standing in the beverage line between dispensing of beverages or where a large number of beverages are dispensed in a short period.

In addition, it has been found that such standard pythons used with a cooler in a cellar are unable to meet the present demands for colder beverages without marked increases in power demands which have a detrimental affect on the operation of the cooler. In a typical remote cooler used for cooling a number of beverage lines, the cooler comprises a water bath and an ice bank. The ice bank serves to cool the water bath and the water bath cools in turn the beverage lines that pass therethrough. In addition, the water bath of the cooler supplies the cooling water which flows in the cooling circuit of the python. It will be apparent that the cooling water returning from the dispensation site to the cooler will be at a higher temperature than the cooling water in the water bath. If the temperature of the returning cooling water is too high, the cooler becomes unable to maintain the temperature of the

- 3 -

cooling bath without the ice bank melting. Eventually, this leads to the cooler being unable to cool the beverage lines sufficiently to meet the specified dispense temperatures. For this reason, it is common practice to limit the

5 additional thermal loading applied to the cooling circuit of the cooler by items connected to the cooling circuit. For example, it is known to provide dispense fonts at the dispensation site with a feature known as a cooling loop wherein a portion of the cooling water flowing in the python

10 is diverted through pipework in the dispense font to cool the beverage flow lines in the locality of the dispense tap. Each dispense font of this type connected to the cooling circuit of the python adds a thermal load to the cooling circuit. A typical known cooling loop in a dispense font

15 adds 10 watts equivalent heating to the cooling circuit.

An alternative method of attempting to cool the beverage in the font and also to provide condensation on the outer surfaces of a font is to flood the font housing with a cooling medium such as water. However, such flooded fonts

20 typically add around 140 Watts of heating to the cooling circuit. It will be apparent that use of a number of these fonts can quickly overload the cooling capacity of the remote cooler.

A further problem in controlling dispensation

25 temperatures of beverages on draft is that in many public houses or bars the cooling circuit is used to cool beverages from more than one supplier who may have different dispense specifications or requirements. For this reason, it is common practice to require the total additional thermal

30 loading to be applied to the cooling circuit and hence the cooler to be less than 100 watts equivalent heating to ensure that the ice bank of the cooler is not melted in use.

- 4 -

In addition, it is a common requirement that the minimum flow rate of cooling water through the python and remote cooler is 4 litres/minute. In practice this limits the number and type of dispense fonts that can be connected to the cooling circuit and the temperatures of beverages dispensed from those dispense fonts. Typical achievable dispense temperatures range from 6 to 10 degrees Celsius.

It has also previously been proposed to solve this problem by transporting the beverage from the cellar to the dispensation site and then cooling the beverage locally at the dispensation site using a cooler known as a flash cooler. This arrangement does allow colder beverages to be dispensed down to around 3 degrees Celsius. However, it is necessary to provide a flash cooler at the dispensation site. If the bar or other dispensation site has a number of beverage lines then a number of flash coolers are required. This leads to increased expense in providing the flash coolers in the first place and in maintaining and repairing the coolers. Further, locating the flash coolers at the dispensation site leads to a lack of storage space for other items such as bottled beverages, glassware etc. Further, the flash coolers output a considerable amount of heat which can result in unpleasant working conditions for bar staff leading to the need for further air conditioning.

It is an object of the present invention to provide an apparatus for dispensing beverages which allows for space at the dispensation site to be reclaimed by allowing removal of bulky flash coolers from the dispensation site but still allow beverages to be dispensed at colder temperatures.

Accordingly, the present invention provides apparatus for cooling draft beverages comprising:

a beverage line;

a dispensation font located at a dispensation site, the dispensation font comprising one or more taps;

a cooling pod provided at the dispensation site;

the beverage line extending to the dispensation font
5 for transporting beverage to the one or more taps;

the beverage line running to the dispensation site within a python;

the python comprising one or more cooling lines for transporting a cooling medium to and from the dispensation
10 site;

the cooling pod comprising a cooling chamber through which the beverage line passes, the beverage line being coiled within the cooling chamber, the cooling chamber comprising an inlet connected to the cooling line of the
15 python for receiving the cooling medium and an outlet connected to the cooling line of the python for discharging cooling medium back to the python;

wherein the cooling pod further comprises a cooling pipe connected to the inlet of the cooling chamber and
20 extending within the coiled beverage line, the cooling pipe comprising a plurality of radially directed apertures through which, in use, the cooling medium can pass into the cooling chamber in the form of a jet, so as to impinge on an inwardly directed face of the coiled beverage line.

25 Advantageously, the apparatus of the present invention does not require the provision of a flash cooler for each beverage line or dispense font at the dispensation site. Instead, the primary cooling may be carried out at a remote site by a primary cooler. Local
30 cooling is carried out using the cooling pods which are provided at the dispensation site. The cooling pods may be provided either above or below bar level and may optionally form part of the dispense font itself. As a

result, extra space is freed up in the bar area and the degree of heat output by the cooling system is considerably reduced.

The beverage line in the cooling chamber is coiled.

5 Advantageously the cooling pipe is located within the coiled beverage line. Also advantageously the apertures in the cooling pipe are radially directed such that cooling medium passing therethrough impinges on an inwardly directed face of the coiled beverage line.

10 Preferably the cooling pod further comprises exterior insulation.

In one aspect the cooling pod may be connected in series with the cooling line of the python such that the entire flow of cooling medium in the cooling line of the
15 python passes through the cooling pod. By connecting the cooling pod in series with the cooling lines of the python, the efficiency of cooling of the pods is greatly increased. This allows for a cooling pod to be utilised in combination with a remote primary cooler rather than
20 requiring a flash cooler to be provided at the dispensation site.

The cooling pod may add less than 30 Watts equivalent heating to the apparatus.

The one or more taps may be adapted for dispensing
25 beverages with foamed heads by means of utilising separate flow paths for a bulk portion of the beverage to be dispensed and a foamed portion of the beverage to be dispensed, wherein the tap defines two beverage flow paths, wherein one of the beverage flow paths is provided
30 with a flow restriction for inducing turbulence in the beverage flow for producing foam and comprises an outlet angled at between 0 and 60 degrees to the horizontal so that foam

dispensed from the outlet does not fob an already dispensed bulk portion of the beverage.

The present invention also provides a cooling pod for use at the dispensation site of an apparatus for cooling draft beverages, the apparatus comprising:

a beverage line;

a dispensation font located at a dispensation site, the dispensation font comprising one or more taps;

the beverage line extending to the dispensation font for transporting beverage to the one or more taps;

the beverage line running to the dispensation site within a python;

the python comprising one or more cooling lines for transporting a cooling medium to and from the dispensation site,

wherein the cooling pod comprises a cooling chamber through which the beverage line passes, the beverage line being coiled within the cooling chamber, the cooling chamber comprising an inlet connected to the cooling line of the python for receiving the cooling medium and an outlet connected to the cooling line of the python for discharging cooling medium back to the python; and

wherein the cooling pod further comprises a cooling pipe connected to the inlet of the cooling chamber and extending within the coiled beverage line, the cooling pipe comprising a plurality of radially directed apertures through which, in use, the cooling medium can pass into the cooling chamber in the form of a jet, so as to impinge on an inwardly directed face of the coiled beverage line.

- 8 -

The invention will firstly be illustrated, as shown in Figures 1 to 4, in a system comprising a single dispense font 1, a cooling pod 10, a python 20, a remote primary cooler 23 and a secondary cooler 24. The font 1 is located at a dispensation site, such as a bar area of a public house. The primary cooler 23 is located at a remote site separated from the bar area, such as a cellar. The python 20 extends between the dispensation site and the remote site. The location of the cooling pod 10 and secondary cooler 24 will be described below.

The remote primary cooler 23 comprises a housing 40 in which are located a cooling mechanism and a pumping mechanism. The cooling mechanism comprises a water bath 41 through which one or more beverage supply line 33 passes. Preferably, the beverage supply lines are formed into a coiled configuration 42 within the water bath 41 to improve heat transfer between the water in the water bath and the beverage in the beverage supply lines. The water bath 41 is itself cooled by an ice bank (not shown) which is formed by a refrigeration mechanism of known type. Typically, the remote primary cooler 23 is sited in a cellar or back room.

The dispense font 1 comprises a housing 4 which is mountable to a bar or similar surface visible to the customer and on which is mounted a tap 2 of a type for dispensing draft beverages. The tap 2 is connected to a beverage line 3 which runs through an interior of the housing 4 and extends from the housing 4 for connection to an external supply.

According to the present invention the cooling pod 10, as shown in Figure 2, comprises a housing 11 defining a cooling chamber 18. The cooling chamber 18 is provided with a water inlet 16 and a water outlet 17 for accommodating

flow of water (or other cooling medium) through the cooling chamber 18. A cooling coil 12 is provided within the cooling chamber 18 and connects between a beverage inlet 14 and a beverage outlet 15. The beverage line 3 of the dispense font 1 connects to the beverage outlet 15 of the cooling pod 10. The cooling pod 10 includes an elongated pipe 60 connected to the water inlet 16. The pipe 60 has a closed end 63 at a distal end from the water inlet 16 and a number of holes 62 spaced along the length and around the circumference of the pipe 60. The pipe 60 is located within the cooling coil 12 such that water exiting the holes 62 impacts as a spray on the inside surface of the coil 12. The housing 11 is surrounded by insulation 19 to minimise heat transfer between the cooling pod 10 and the surroundings. The insulation 19 is an expanded foam insulation.

The cooling pod 10 is located at the dispensation site. It may be located above or below bar level and may optionally be incorporated into the housing 4 of the dispense font 1.

The python 20, as shown in Figure 4, comprises a conduit in which runs the one or more beverage supply lines 33 and cooling lines 21, 22. The cooling lines comprise an outward cooling line 21 and a return cooling line 22. An insulated sheath 25 of the python provides the python with structural integrity and also helps prevent heat transfer between the interior of the python 20 and the surroundings. As shown in Figure 4, the python 20 contains sixteen beverage supply lines 33. The number of beverage supply lines 33 within the python 20 can be varied depending on the number of dispense fonts 1 that require connection. In the embodiment shown in Figure 1, for the sake of clarity, only a single beverage supply line 33 is shown.

As shown in Figure 1, the python 20 extends from the remote primary cooler 23 to the dispensation site. The outward cooling line 21 extends from the water bath 41 and connects to the water inlet 16 of the cooling pod 10. The beverage supply line 33 runs from the primary cooler 23 and connects to the beverage inlet 14 of the cooling pod 10.

Traditionally, the beverage supply lines 33 of pythons are 9.5mm (3/8") pipes. In addition, in previous cooling loop design it is usual to use 9.5mm (3/8") pipes. The standard cooling line pipe in a python is 15mm diameter. In the present invention, the cooling coil 12 of the cooling pod 10 is a 8mm (5/16") pipe which is connected to the 9.5mm (3/8") beverage supply line 33 at the beverage inlet 14 by means of a coupling 13.

The cooling lines 21, 22 of the python 20 and the cooling pod 10 together form a cooling circuit through which the cooling water flows continuously.

The dispense font 1, as shown in Figure 3, is further provided with a cooling loop 5 which comprises a font cooling line 9 which is connected to the water outlet 17 of the cooling pod 10. The font cooling line 9 runs within the font housing 4 in close proximity to the beverage line 3. As shown in Figure 1, the cooling loop further comprises a condensation mechanism 6 located at or near a front face of the housing 4. By 'front face' is meant the face of the dispense font 1 facing the customer in use.

The condensation mechanism 6, as shown in Figure 3, comprises a portion 8 of the cooling loop 5 and a condensation plate 50 in thermal contact with one another. The thermal contact is achieved by the provision of bridge structures (not shown) spanning between the portion 8 of the cooling loop 5 and a rearward, interior surface of the condensation plate 50. Preferably, the bridge structures

- 11 -

comprise raised portions of the rear face of the condensation plate which rest against the cooling loop portion 8. The raised portions are shaped with a dished semi-circular cross-section to form a close interface with
5 the rounded portion 8 of the cooling loop pipework. The bridge structures, like the condensation plate are formed from a thermally conductive material, such as metal. Preferably the bridge structures are formed as a single piece with the rest of the condensation plate 50 by means
10 of, for example, a casting process. The portion 8 of the cooling loop 5 is encompassed in an insulator 52 such as expanded polyurethane foam. The insulator 52 is also formed in contact with the interior surface of the condensation plate 50 except for the locations of the bridge structures.
15 The insulator 52 also acts to compress the bridge structures of the condensation plate 50 and the portion 8 of the cooling loop 5 together to maintain a good thermal contact. Optionally, the insulator 52 can fill the entire void space of the housing 4 of the dispense font 1.

20 The cooling loop 5, comprising the font cooling line 9 and the portion 8 of the cooling loop 5 in thermal contact with the condensation plate 50, is preferably a single length of pipework such that a single continuous flow of water passes through the cooling loop 5 to effect cooling of
25 the beverage line 3 and condensation on the condensation plate 50. In other words, the font cooling line 9 and the condensation mechanism 6 are cooled in series by the same cooling water. Optionally, as shown in Figure 3, the font cooling line 9 may also form a portion, or the whole of, the
30 portion 8 in thermal contact with the condensation plate 50. Also, optionally, the beverage line 3 may be cooled by more than one length of the cooling loop 5. For example, as shown

in Figure 3, the beverage line 3 is cooled by inward and outward legs of the cooling loop 5.

The cooling loop 5 is preferably formed from 15mm pipes which are the same diameter as the cooling lines 21, 22 of the python 20. The use of 15mm lines in the font 1 maximises the cooling effect of the cooling loop 5 and minimises flow restrictions, thus helping to ensure that the overall flow rate of cooling water through the cooling circuit is maintained above the required minimum level of 4 litres/minute.

The cooling loop 5 forms a part of the cooling circuit and is connected in series with the outward cooling line 21 and the return cooling line 22. The cooling loop pipework extends from the dispense font 1 and connects to the return cooling line 22 of the python 20. The entire flow of cooling water in the cooling circuit passes sequentially through the outward cooling line 21, cooling pod 10, cooling loop 5 and return cooling line 22.

The secondary cooler 24 is preferably a flash cooler as known in the art. However, the secondary cooler 24 in the present apparatus is used to cool the return cooling line 22 rather than the beverage supply line 33. As shown in Figure 1, the return cooling line 22 passes through the secondary cooler 24 before reaching the primary cooler 23. The secondary cooler 24 is a flash cooler type comprising a 15cc compressor and a 10 kg ice bank to ensure that it has sufficient capacity to cool the water in the return cooling line 22. The cooling coil in the secondary cooler 24 is preferably 6 metres in length and 12.7 mm (1/2 inch) diameter.

It should be noted that for clarity, the structure of the python 20 is not shown in Figure 1 as extending the entire way between the primary cooler 23 and the

- 13 -

dispensation site. In practice, the python 20 would extend for the whole distance between the primary cooler and the dispensation site. In addition, the overall python 20 may comprise separate lengths spanning between components of the apparatus. For example, one length of the python 20 could extend from the primary cooler 23 to the cooling pod 10. A separate length of python may be utilised to span any gap between the dispense font 1 and the secondary cooler 24. Either a portion of the python, or separate insulation may be used to insulate the lines as they extend from the cooling pod 10 to the dispense font 1. As will be understood, a single length of python is preferably to cover the distance between the remote location and the dispensation site. However, one or more sections of python may be required at the dispensation site to properly insulate individual lines and connections.

In use, operation of the tap 2 causes beverage to be dispensed. The beverage is dispensed by means of a gas-pressurised system (not shown) or alternatively by a pumping mechanism located in the cellar. Beverage is passed from a storage keg (or similar container) in the cellar along the beverage supply line 33. The beverage passes through the cooling coil 42 in primary cooler 23 where it is cooled by action of the water bath. Typically, beverage entering the primary cooler will be at a temperature or around 12 degrees Celsius. On leaving the primary cooler 23 the temperature will typically be between 5 and 7 degrees Celsius.

The beverage flows through the python 20 to the dispensation site and is fed into the cooling pod 10 via coupling 13. At the point of reaching the cooling pod the beverage will typically have risen in temperature by around

1 to 2 degrees Celsius or so - and as a result be at a temperature of between 6 and 10 degrees Celsius.

The beverage flows through the cooling coil 12 where it is cooled by the cooling water in the surrounding cooling chamber 18. On leaving the beverage outlet 15 of the cooling pod 10 the beverage temperature of between 3 and 5 degrees Celsius dependant on the entry temperature of the beverage, the flow rate of the beverage and the dispense rate of beverage (i.e. the number of beverages dispensed in a set time period).

The beverage then flows through the beverage line 3 to the tap 2 where it is dispensed. Between the cooling pod 10 and the tap 2 the beverage temperature is maintained by thermal contact with the font cooling line 9 of the cooling loop 5.

As a result, the temperature of the beverage when dispensed from the tap 2 is typically between 3 and 5 degrees Celsius. Advantageously, as can be seen, the temperature of the beverage between the cooling pod 10 and the tap 2 is substantially unchanged.

The pumping mechanism of the remote cooler 23 operates to pump cooling water from the water bath 41 of the primary cooler 23 through the cooling circuit of the outward cooling line 21, cooling chamber 18 of the cooling pod 10, cooling loop 5, and return cooling line 22. All of the cooling water in the outward cooling line 21 passes through the cooling chamber 18 of the cooling pod 10 and is then diverted through the cooling loop 5 before returning to the primary cooler 23 via the return cooling line 22. The cooling water enters the cooling pod 10 via the elongate pipe 60. Since the pipe is closed at the distal end 63 the water is forced out radially in the form of a jet through

holes 62 onto the cooling coil 12. Forming the cooling water into a jet in this way helps to minimise the pressure drop in the cooling circuit whilst maximising the cooling effect of the water. In addition, the use of a jet
5 minimises the effect of the cooling pod's presence on the overall flow rate in the cooling circuit. Finally, the use of a jet invokes turbulence in the water within the cooling chamber 18 which prevents the formation of air locks or temperature layers within the chamber which would
10 impair the cooling effect.

As indicated above, the cooling loop 5 serves the purpose of maintaining the temperature of the beverage in the beverage line 3 whilst in the dispense font 1 and before being dispensed by tap 2. In addition, the cooling
15 loop 5 comprises the condensation mechanism 6. Flow of the cooling water through the pipework 8 of the condensation mechanism 6 cools the pipework 8 and in turn the condensation plate 50 via the thermal contact between the pipework 8 and the condensation plate 50 by means of the
20 bridge structures. Cooling of the condensation plate 50 causes condensation to form on the exterior face of the condensation plate 50 where water vapour in the atmosphere at the dispensation site condenses on the relatively cold surface of the condensation plate 50.

25 The return cooling line 22 is passed via the secondary cooler 24 on its way to the primary cooler 23. The temperature of the cooling water in the return cooling line 22 is reduced from between 4 and 2 degrees Celsius to between 2 and 1 degrees Celsius.

30 An example of the results of using the present apparatus are shown in Figure 6. Figure 6 shows a graph of dispensation temperature in degrees Celsius versus the

- 16 -

number of beverages dispensed. In the illustrated test, beverage at an initial temperature of 8 degrees Celsius on entering the cooling pod 10 was dispensed at a volume flow rate of 15 seconds per pint. Drink numbers 1 to 9 were
5 dispensed at an interval rate of one pint per minute. Drink numbers 10 to 19 were dispensed at an interval rate of two pints per minute. Cooling water was pumped through the cooling circuit at a flow rate of 5 litres per minute. As can be seen, the dispensation temperature of the first nine
10 beverages was between 4.5 and 4.3 degrees Celsius. The dispensation temperature of the second nine beverages was between 4.3 and 4.7 degrees Celsius.

Figure 5 illustrates a second embodiment of apparatus according to the present invention in which a plurality of
15 dispense fonts 1 are connected to the primary cooler and the secondary cooler 24. In the illustrated embodiment three dispense fonts 1a, 1b and 1c are connected. However, the apparatus may be used for two, three or more dispense fonts.

Like components in the second embodiment to those
20 described above in respect of the first embodiment have been referenced by like numerals. The python 20 comprises an outward cooling line 21 and a return cooling line 22 as in the first embodiment and also a plurality of beverage supply lines 33a, 33b, 33c. Each beverage supply line 33 feeds an
25 individual cooling pod 10a, 10b, 10c, each of which are connected to a respective dispense font. As will be seen from Figure 5, the outward cooling line 21 feeds the first cooling pod 10a to supply cooling water in the manner described above. Cooling water leaving the cooling pod 10a
30 passes via the cooling loop 5a and passes back to the python 20. Thereafter, the same cooling water is passed to the second cooling pod 10b and then through the second cooling

- 17 -

loop 5b and so on down the line of dispense fonts. After leaving the terminal dispense font 1c, the cooling water flows via the return cooling line 22 to the primary cooler via the secondary cooler 24 in the manner described above with reference to the first embodiment. It will be apparent that the cooling pods 10a, 10b and 10c and the cooling loops 5a, 5b and 5c are connected in series such that the entire flow of cooling water in the outward cooling line 29 passes through the cooling pods and cooling loops in turn before being returned to the primary cooler via the return cooling line 22.

An advantage of the present invention is its ability to maintain good uniformity of beverage dispense temperature between multiple dispense fonts are connected to a single python by installing a cooling pod 10 at one or more of the dispense font 1 locations. Figure 7 shows a comparative test of dispense temperatures from ten dispense fonts connected and supplied by a single python. In the test illustrated each dispense font in test A comprised a cooling pod 10 and cooling loop 5 as described above. In test B the dispense fonts at positions 1, 3, 5, 7 and 9 have no cooling mechanism and the dispense fonts at positions 2, 4, 6, 8 and 10 are provided with a cooling loop as known in the art. As can be clearly seen the apparatus of the present invention is able to maintain a higher uniformity and overall lower dispense temperatures than prior systems.

Figure 8 illustrates a third embodiment of apparatus embodying the present invention. Like components in the third embodiment to those described above in respect of the above embodiments have been referenced by like numerals.

The third embodiment differs from the previous embodiments in that the cooling loop 5 is not formed in

- 18 -

series with the cooling pod 10 and condensation mechanism 6. Instead the cooling loop 5 is formed as a branch off the cooling circuit of the python 20. As shown, the cooling loop branch-off point is located downstream of the cooling pod 10 and the condensation mechanism 6. In use, the cooling medium, typically water, flows through the cooling circuit of the python with the entire flow first passing through the cooling pod 10 and then the condensation mechanism 6. The cooling medium then returns to the python. At least a portion, but not necessarily all, of the cooling medium is subsequently diverted off into the cooling loop 5 where it aids maintenance of the beverage temperature in the beverage line 3.

Figure 9 illustrates a fourth embodiment of apparatus embodying the present invention. Like components in the fourth embodiment to those described above in respect of the above embodiments have been referenced by like numerals.

As with the third embodiment described above, the cooling loop 5 of the fourth embodiment is formed as a branch. In addition, the fourth embodiment differs from the third embodiment in that the condensation mechanism 6 is separate from the primary cooling circuit of the python. As shown, the condensation mechanism comprises pipework 88 connected to a secondary cooling circuit comprising a dedicated cooler 90 for cooling a glycol cooling medium. The outlet from the cooling pod 10 is directed immediately back to the python rather than entering the font housing 4.

In use glycol from the cooler 90 at a temperature of around -7 degrees Celsius is pumped through the pipework 88 and consequently the condensation plate 50 is subject to a high degree of cooling which results in the formation of ice and/or a frosting effect on the exterior of the plate 50.

- 19 -

A potential disadvantage of using glycol in a beverage font is that the low temperature of the glycol can lead to freezing of liquids in the beverage line 3. This is particularly the case when the beverage line is subjected to cleaning cycles using water. Advantageously, the present font provides insulation between the cooling circuit used for the glycol, and the beverage line 3. Within the font housing the insulation 52 surrounding the condensation pipework helps to prevent heat transfer from the beverage line 3. In addition, advantageously, the cooling water can be circulated within the cooling loop 5 at the same time as glycol is circulated in the secondary cooling circuit. The cooling water, typically at around 2 degrees Celsius helps to maintain the cleaning water in the beverage line 3 at above its freezing point. As a result it is possible to clean the beverage line 3 without having to first switch off the glycol circulation or the cooling water circulation.

Advantageously, it will be understood that the same beverage font housing 4 and internal pipework may be utilised for carrying out the modes of operation described with reference to Figures 8 and 9 simply by altering the external connections. In particular, the condensation plate 50, pipework 8/88, insulation 52, cooling loop 5 and tap 2 may be unchanged. By suitably altering the external connections the font may quickly and easily be turned from a condensating font into a font which produces a frozen ice effect. In addition, the font may work as a standard non-condensing font wherein the cooling loop 5 and pipework 8/88 are not connected to external sources of cooling medium. Thus, a single design of font can readily achieve a number of desired dispense effects and temperature profiles.

- 20 -

The embodiments described above have been given as examples only of the present invention. Variations may be made without departing from the scope of the following claims. For example, the taps 2 mounted to the dispense fonts 1 may be any suitable tap for dispensing draft beverage. In particular, the taps 2 may be of the type described in the applicant's European patent EP 1138628 which are particularly suitable for dispensing beverages with foamed heads by means of utilising separate flow paths for the bulk portion of the beverage to be dispensed and the foamed portion of the beverage to be dispensed. The tap defines two beverage flow paths, wherein one of the beverage flow paths is provided with a flow restriction for inducing turbulence in the beverage flow for producing foam and comprises an outlet angled at between 0 and 60 degrees to the horizontal so that foam dispensed from the outlet does not fob an already dispensed bulk portion of the beverage.

Optionally the beverage flow path direction at the outlet may be substantially horizontal.

Two taps may be provided, each defining one of the beverage flow paths. Alternatively, a single tap may be provided comprising a housing comprising two chambers defining the two beverage flow paths.

A valve may be provided upstream of the chambers movable from a first position in which an inlet to the chamber containing the flow restriction is closed and an inlet to the other chamber is open, to a second position in which the inlet to the chamber containing the flow restriction is open and the inlet to the other chamber is closed.

The flow restriction may be an orifice plate.

- 21 -

Advantageously, this tap is particularly suitable for use with the cooling systems of the present invention since it is able to dispense good quality, stable heads on beverages at low temperatures. Previously, formation of heads on cold beverages has been difficult.

The fonts 1 may also be provided with means for illuminating the electrical supply for illuminating fonts may be incorporated into the python 20 or may be provided by separate electrical supply provided locally at the dispensation site.

The fonts 1 may be provided each with a single dispense tap 2 or may have multiple dispense taps 2 provided. For example, a dispense font 1 may be in the form of a T-bar font known in the art. The fonts 1 may be free flow fonts where control of the quantity dispensed is determined by the length of time that the tap 2 is opened or alternatively the fonts may be metered fonts whereby control of the volume of beverage dispensed is controlled by electronic means to allow for semi-automatic operation of dispensing.

The secondary cooler 24 may be located at the dispensation site or alternatively may be located at the remote site such that the return cooling line 23 is cooled immediately prior to the line connecting to the primary cooler 23. Where the secondary cooler 24 is located at the dispensation site, the secondary cooler 24 may be located after the terminal dispense font in the run of dispense fonts or may be positioned part way along the run of the dispense fonts, for example between fonts 1b and 1c as shown in Figure 5.

The present invention has been described by way of example with the cooling medium passing through the primary

- 22 -

cooling circuit of the python 20 being water. However other cooling mediums may be used.

CLAIMS

1. Apparatus for cooling draft beverages comprising:
 - a beverage line;
 - 5 a dispensation font located at a dispensation site, the dispensation font comprising one or more taps;
 - a cooling pod provided at the dispensation site;
 - the beverage line extending to the dispensation font for transporting beverage to the one or more taps;
 - 10 the beverage line running to the dispensation site within a python;
 - the python comprising one or more cooling lines for transporting a cooling medium to and from the dispensation site;
 - 15 the cooling pod comprising a cooling chamber through which the beverage line passes, the beverage line being coiled within the cooling chamber, the cooling chamber comprising an inlet connected to the cooling line of the python for receiving the cooling medium and an outlet
 - 20 connected to the cooling line of the python for discharging cooling medium back to the python;
 - wherein the cooling pod further comprises a cooling pipe connected to the inlet of the cooling chamber and extending within the coiled beverage line, the cooling
 - 25 pipe comprising a plurality of radially directed apertures through which, in use, the cooling medium can pass into the cooling chamber in the form of a jet, so as to impinge on an inwardly directed face of the coiled beverage line.
- 30 2. Apparatus as claimed in claim 1 wherein the cooling pod further comprises exterior insulation.

3. Apparatus as claimed in claim 1 or 2 wherein the cooling pod is connected in series with the cooling line of the python such that the entire flow of cooling medium in the cooling line of the python passes through the
5 cooling pod.

4. Apparatus as claimed in any one of the claims 1 to 3 wherein the cooling pod adds less than 30 Watts equivalent heating to the apparatus.
10

5. Apparatus as claimed in any one of the preceding claims wherein the one or more taps are adapted for dispensing beverages with foamed heads by means of utilizing separate flow paths for a bulk portion of the
15 beverage to be dispensed and a foamed portion of the beverage to be dispensed, wherein the tap defines two beverage flow paths, wherein one of the beverage flow paths is provided with a flow restriction for inducing turbulence in the beverage flow for producing foam and
20 comprises an outlet angled and between 0 and 60 degrees to the horizontal so that the foam dispensed from the outlet does not fob an already dispensed bulk portion of the beverage.

25 6. A cooling pod for use at the dispensation site of an apparatus for cooling draft beverages, the apparatus comprising:

- a beverage line;
- a dispensation font located at a dispensation site,
30 the dispensation font comprising one or more taps;
- the beverage line extending to the dispensation font for transporting beverage to the one or more taps;
- the beverage line running to the dispensation site within a python;

the python comprising one or more cooling lines for transporting a cooling medium to and from the dispensation site,

5 wherein the cooling pod comprises a cooling chamber through which the beverage line passes, the beverage line being coiled within the cooling chamber, the cooling chamber comprising an inlet connected to the cooling line of the python for receiving the cooling medium and an outlet connected to the cooling line of the python for discharging cooling medium back to the python; and

10 wherein the cooling pod further comprises a cooling pipe connected to the inlet of the cooling chamber and extending within the coiled beverage line, the cooling pipe comprising a plurality of radially directed apertures through which, in use, the cooling medium can pass into the cooling chamber in the form
15 of a jet, so as to impinge on an inwardly directed face of the coiled beverage line.

7. A cooling pod for use at the dispensation site of an apparatus for cooling draft beverages, the apparatus comprising:

20 a beverage line;

a dispensation font located at a dispensation site, the dispensation font comprising one or more taps;

the beverage line extending to the dispensation font for transporting beverage to the one or more taps;

25 the beverage line running to the dispensation site within a python;

the python comprising one or more cooling lines for transporting a cooling medium to and from the dispensation site;

30 wherein the cooling pod is substantially as hereinbefore described with reference to or as shown in Figure 2 of the accompanying drawings.

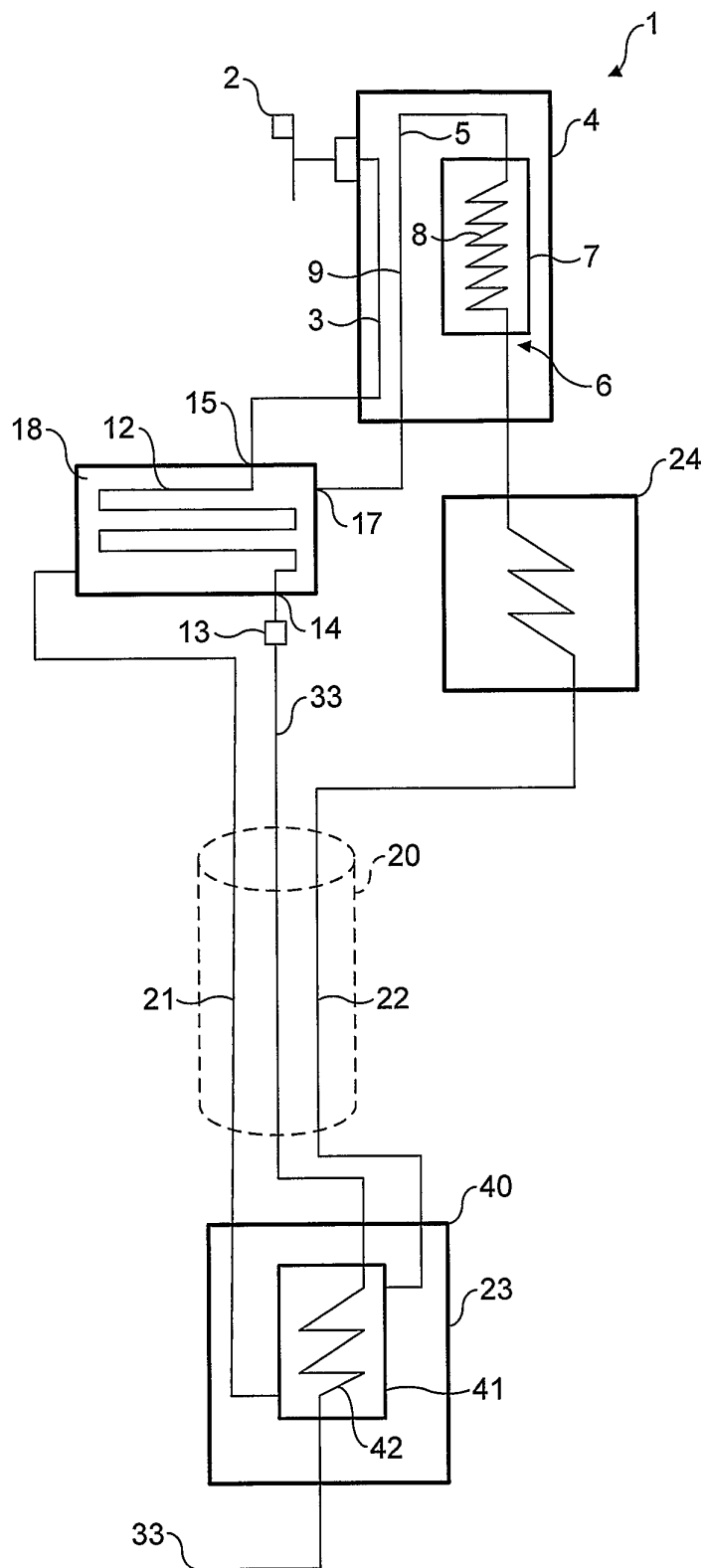

FIG. 1

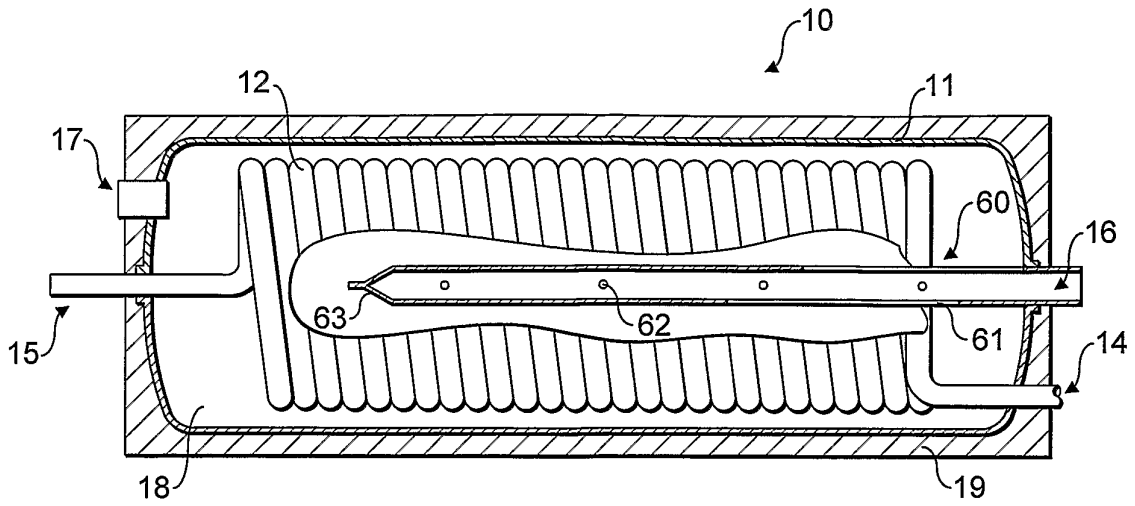

FIG. 2

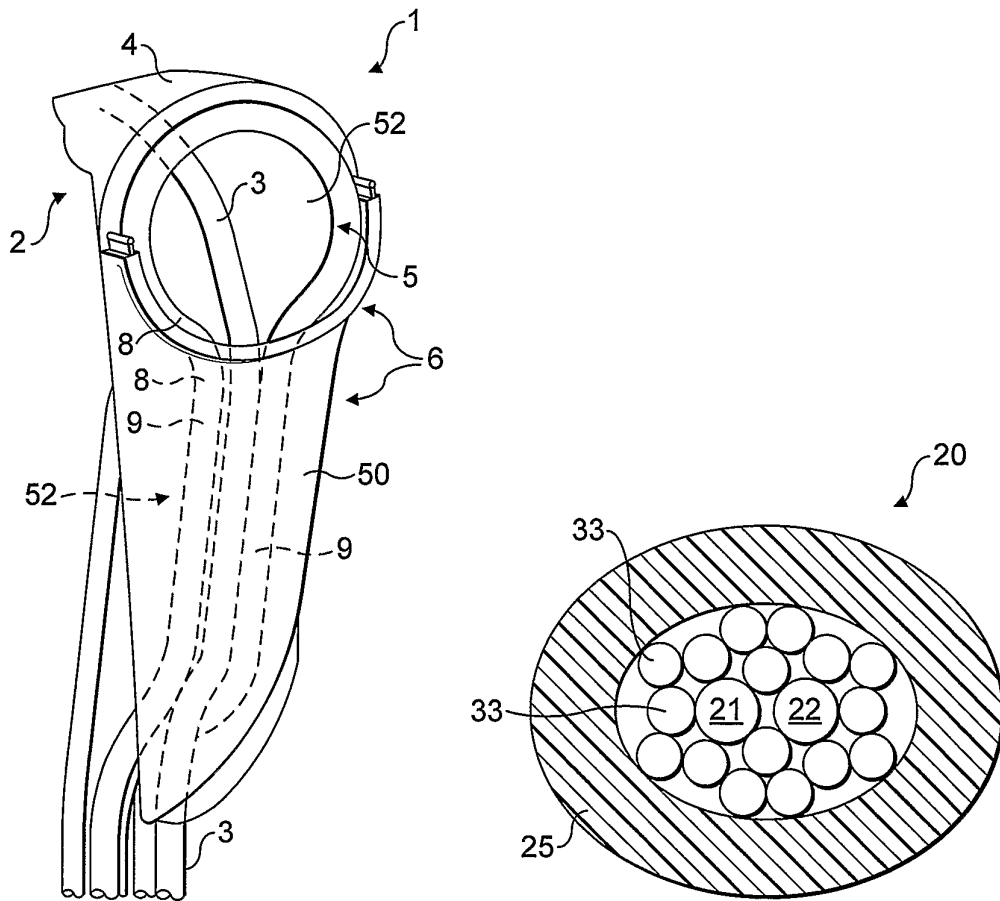

FIG. 3

FIG. 4

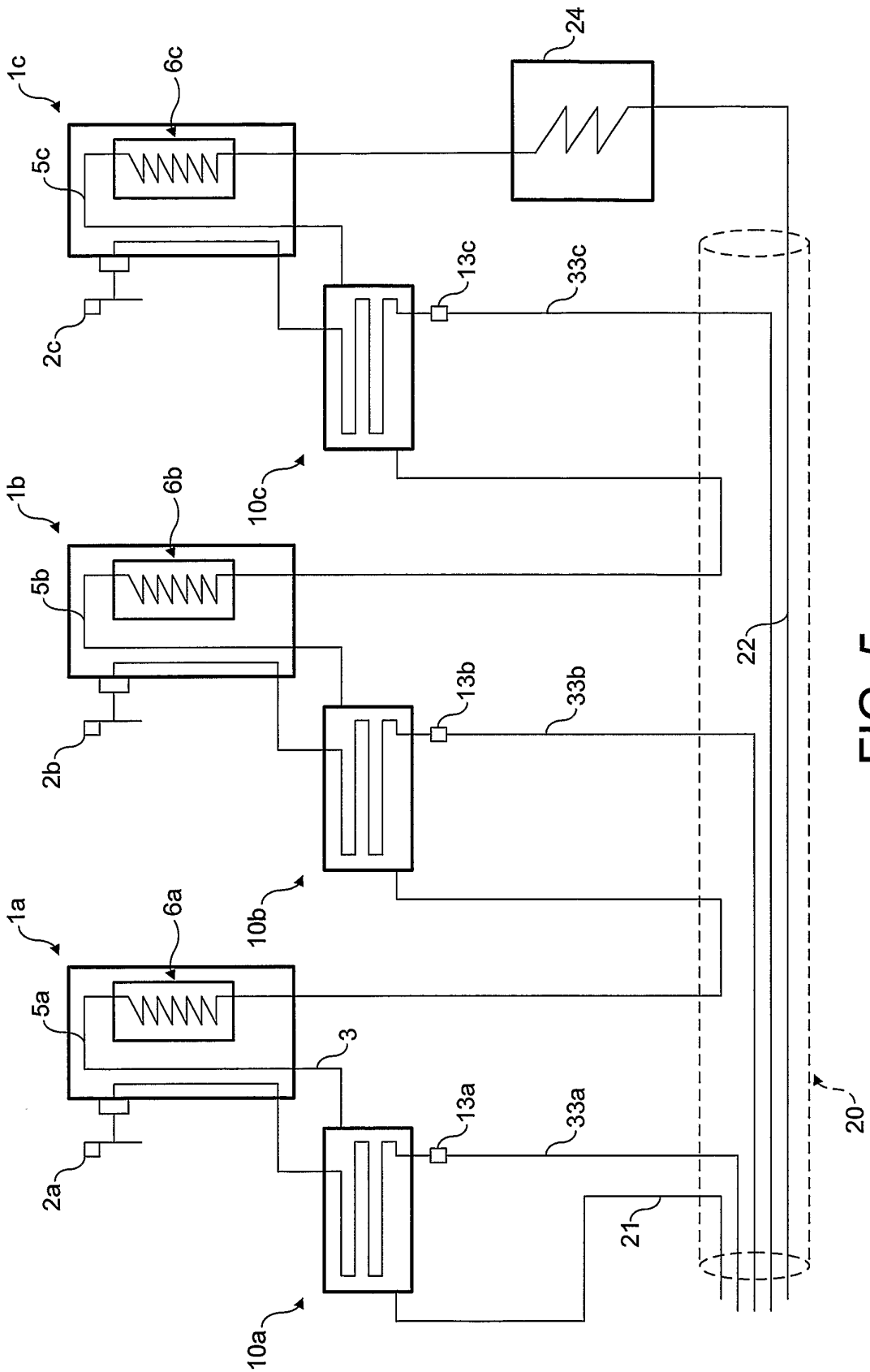

FIG. 5

Drink No	Temp deg.c
1	4.5 (pint/min)
2	4.4
3	4.4
4	4.4
5	4.4
6	4.4
7	4.3
8	4.4
9	4.3
10	4.3 (2pints/min)
11	4.4
12	4.6
13	4.5
14	4.7
15	4.7
16	4.7
17	4.7
18	4.7

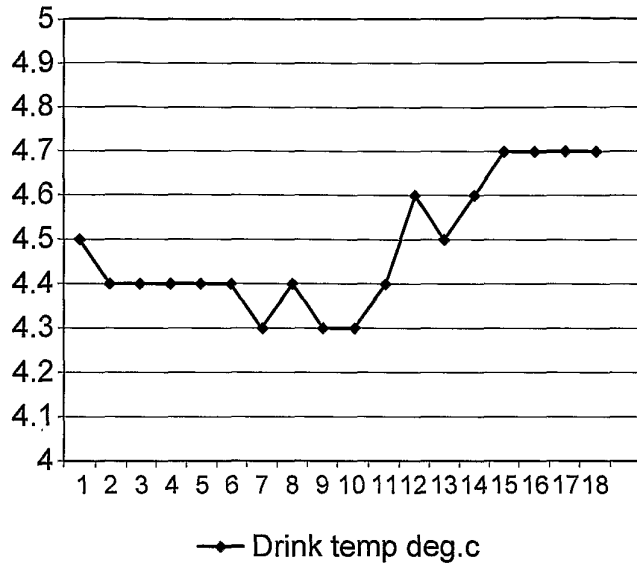

FIG. 6

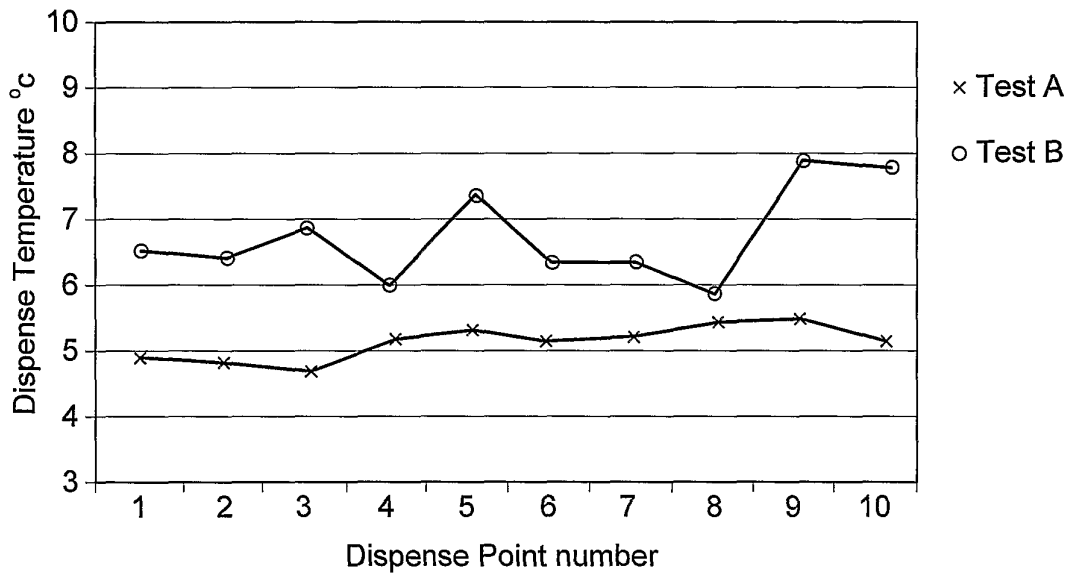

FIG. 7

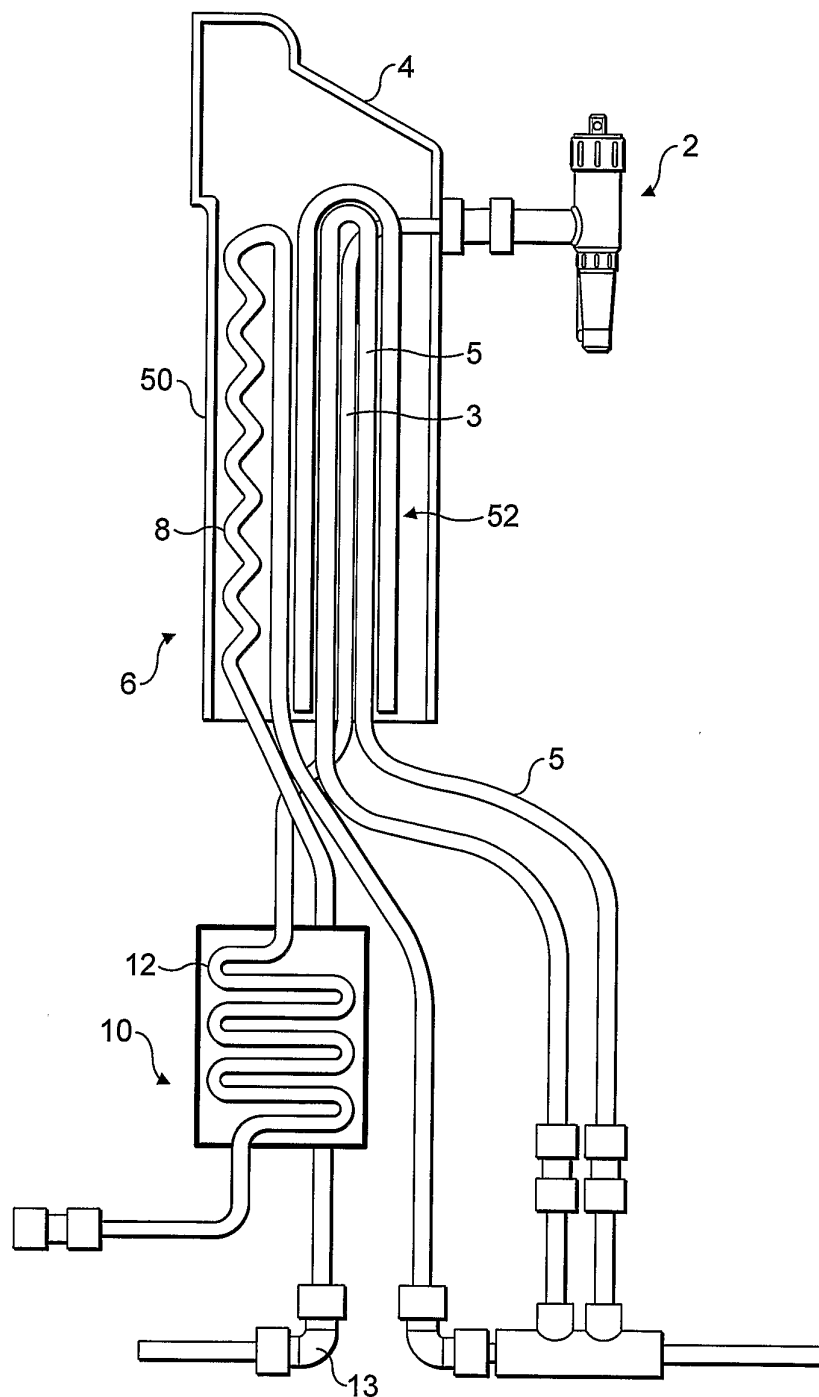

FIG. 8

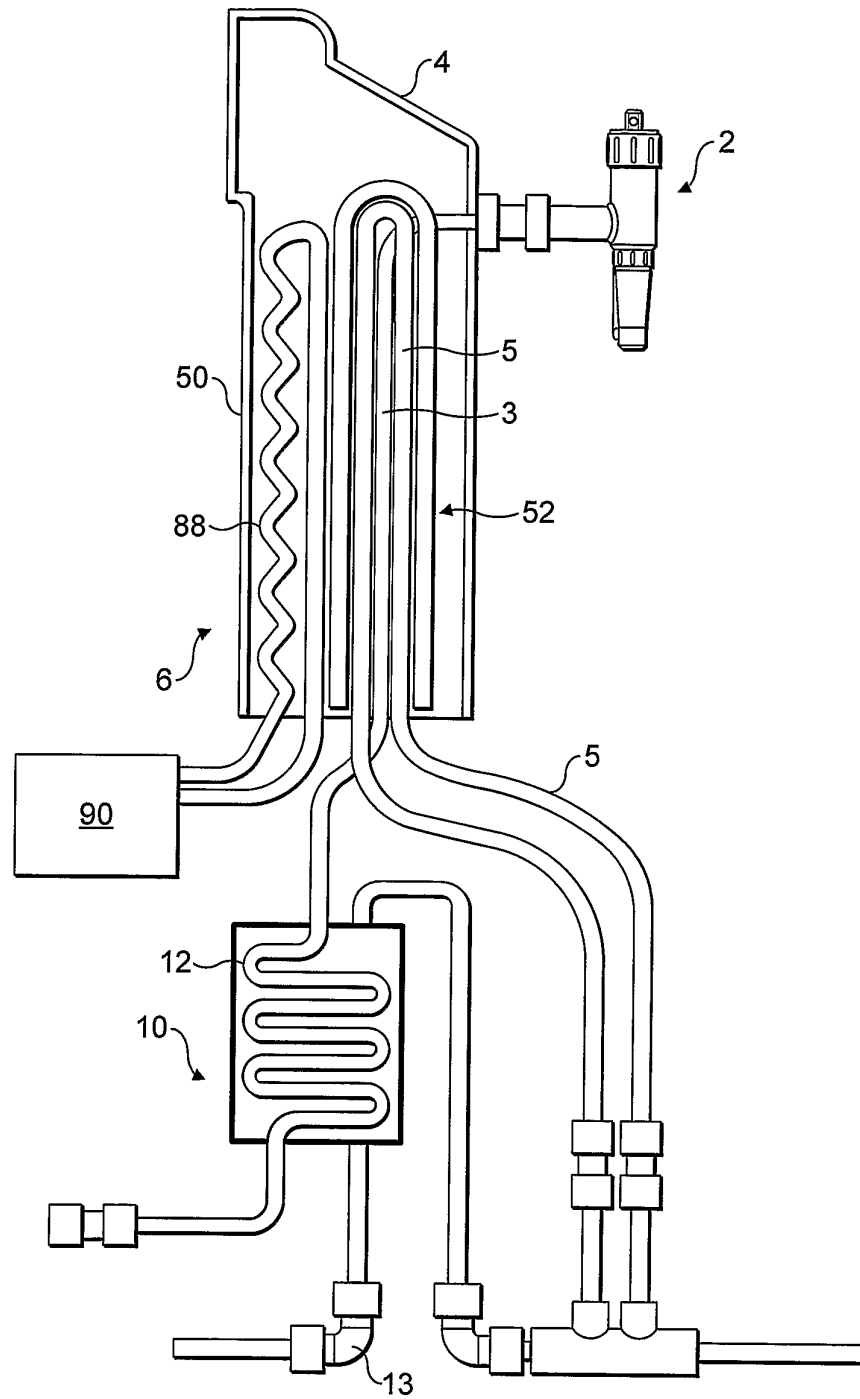

FIG. 9