



(12) **PATENT**

(11) **342779**

(13) **B1**

NORWAY

(19) NO

(51) Int Cl.

E21B 47/16 (2006.01)

E21B 47/117 (2012.01)

Norwegian Industrial Property Office

(21)	Application nr.	20160180	(86)	International Filing Date and Application Number
(22)	Date of Filing	2016.02.03	(85)	Date of Entry into National Phase
(24)	Date of Effect	2016.02.03	(30)	Priority
(41)	Publicly Available	2017.08.04		
(45)	Granted	2018.08.06		
(73)	Proprietor	INDUSTRIAL CONTROLS AS, Midtbergveien 2, 4313 SANDNES, Norge		
(72)	Inventor	Kåre Olav Krogenes, Fjæragata 6, 5521 HAUGESUND, Norge Jan Erik Skjold, Tordenskjolds gate 80, 4009 STAVANGER, Norge		
(74)	Agent or Attorney	HÅMSØ PATENTBYRÅ AS, Postboks 171, 4301 SANDNES, Norge		

(54)	Title	Apparatus and method for transferring information acoustically
(56)	References	
	Cited:	US 2005/0121253 A1, US 2015/0159480 A1, US 2004/0246141 A1
(57)	Abstract	

Apparatus (1, 1') for transferring information acoustically via a tubular (20) comprising at least one signal generator (131-133, 13'), at least one energy source (4, 4'), and means for intrusion into a tubular wall (101, 101') in a desired location, wherein the at least one signal generator (131-133, 13') is arranged to generate signals with a P-wave direction substantially approximating the axial direction of said tubular (20) at said desired location, and the means for intrusion into a tubular wall (101, 101') are adapted for transferring acoustic signals from the apparatus (1, 1') into the tubular (20).

Method for transferring information acoustically via a tubular (20) by means of an apparatus (1, 1') according to claim 1, by establishing an intrusion into the tubular (20) wall by use of the means for intrusion into a tubular (20) wall at a desired location, generating acoustic signals by use of the at least one signal generator (131-133, 13'), and transferring generated acoustic signals from the at least one signal generator (131-133, 13') into the tubular (20) wall via the means for intrusion into the tubular wall (101, 101'), wherein the acoustic signals are generated with a P-wave direction that substantially approximates the axial direction of the tubular (20) at said desired location.

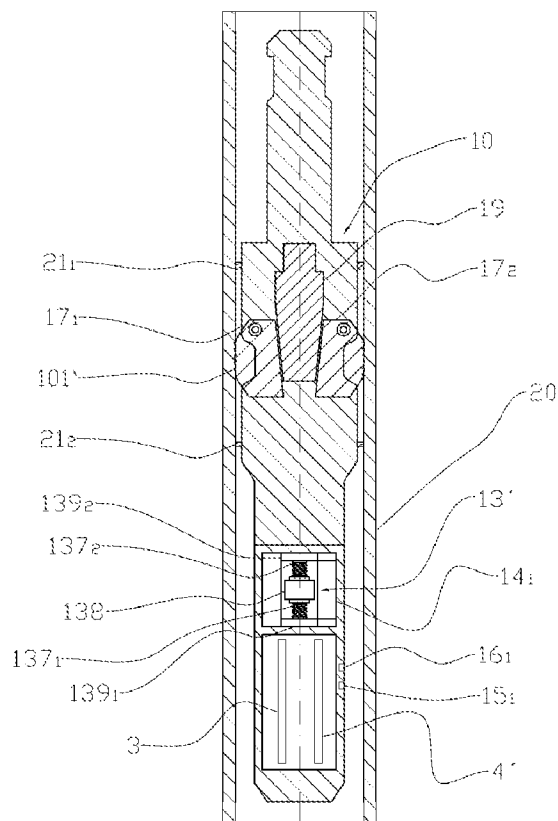

APPARATUS AND METHOD FOR TRANSFERRING INFORMATION ACOUSTICALLY

The invention relates to an apparatus and method for transferring information acoustically. More specifically the invention relates to an apparatus and method for transferring information from a borehole acoustically via a tubular.

5 Gathering information about well conditions is something that is of vital importance in the oil and gas industry, and well known. However, gathering and transferring information from below barriers in a borehole, such as below plugs or valves, can be challenging.

Solutions to the problem exist. US7301472B2 proposes to transfer signals past obstructions in a borehole acoustically by use of a tubing string.

10 US6912177B2 describes transmitting data in a borehole past an obstruction by sending sonic signals along an elongated tubular member, by sending it from a first side of a physical obstruction to a second side of the obstruction, where the second side is located a short distance from the first side. The signal will be received by a receiver on the second side of the obstruction, where it will be stored for later retrieval.

15 Both the referenced patents relate to transmission of signals along an elongate tubular member, such as a drill string, with particular adaptations made to the tubular member prior to lowering into a borehole. Neither of the referenced patents provide a solution for transferring signals past a barrier set in a tubular permanently fixed to the surroundings where such adaptations may not be possible.

20 An acoustic signal may propagate either as a body wave or as a surface wave in an elastic medium with rigidity, such as iron or steel. Surface waves contain little energy and are quickly absorbed by the body's surroundings and are therefore of little use to propagate a signal over a useful distance. Surface waves are often used in ultrasonic inspection equipment.

Body waves are of two types: Primary waves (also called P-waves or pressure waves) and Secondary waves (S-waves or shear waves).

25 In a body wave, the acoustic energy is transferred as a longitudinal wave (P-wave) or as a transverse wave (S-wave) through an elastic medium with rigidity. P-waves may also propagate in liquid or gaseous materials, where S-waves only propagate in solid materials, as shear forces.

A P-wave is a body wave that moves particles within the body back and forth in the same direction and in the opposite direction as the direction the wave is forming and is formed by alternating compressions and rarefactions. An S-wave is a body wave that shakes the body back and forth perpendicular to the direction the wave is moving. The S-wave's energy thus quickly dissipates to the surroundings.

US2005/0121253A1 discloses a telemetry system having: a pipe; a SCADA box acoustically coupled to the pipe; and a gauge inserted in the pipe. The gauge comprises: an acoustic wave generator; a coupler mechanically connected to the acoustic wave generator. The coupler is engageable and disengageable with the pipe, and the coupler defines an acoustic transmission path between the acoustic wave generator and the pipe when engaged with the pipe. The gauge further comprises a signal controller in communication with the acoustic wave generator. Further is disclosed a method for communicating information in a wellbore from a downhole location to the surface, the method having the following steps: running a downhole gauge into a pipe within the wellbore, wherein the downhole gauge comprise an acoustic wave generator; setting the downhole gauge in the pipe; and communicating an acoustic signal between the downhole gauge and the pipe.

The invention has for its object to remedy or to reduce at least one of the drawbacks of the prior art, or at least provide a useful alternative to prior art.

The object is achieved through features, which are specified in the description below and in the claims that follow.

The invention is defined by the independent patent claims. The dependent claims define advantageous embodiments of the invention.

In a first aspect, the invention relates more particularly to an apparatus for transferring information acoustically, the apparatus comprising at least one signal generator, at least one energy source, and means for intrusion into a tubular wall. The signal generator is arranged for the acoustic signals to be generated such that the P-waves of the acoustic signals will have a direction that substantially approximates the axial direction of the tubular. The apparatus is arranged for the acoustic signals to be transferred into the tubular by use of the means for intrusion into the tubular wall.

The apparatus comprises a plug comprising fastening means for anchoring into a tubular wall. The plug's fastening means constitutes the apparatus' means for intrusion into a tubular wall. The plug may be a mechanical tubular plug.

The means for intrusion into a tubular wall may be a single metallic tooth or a set of metallic teeth that can be pushed by force into the tubular wall. Any mechanism suitable for the purpose of forcing the means for intrusion into the tubular wall may be applied, such as a jarring mechanism or a hydraulic system.

The means for intrusion into a tubular wall may be arranged such that at least one of the sides of the means for intrusion into a tubular upon intruding into a tubular wall are substantially perpendicular to the axial direction of the tubular at the point of intrusion. The means for intrusion into a tubular wall may be formed such that both an upper and a lower side of the means for intrusion
5 may be perpendicular to the axial direction of a tubular at a point of intrusion. By upper and lower in this context is meant the position of the sides when intruding into a vertical tubular. Arranging the means for intrusion to be perpendicular to the axial direction of the tubular at the point of intrusion will aid in retaining the direction of the P-waves of the acoustic signals upon transferring the signals from the apparatus into the tubular.

10 Directing the signals' P-waves in the axial direction of the tubular is significantly more efficient than if the P-waves were angled relative to the axial direction, as the signal will travel a shorter distance to reach a receiver a certain distance along the tubular away, and less or no reflections will be needed to reach the receiver. A shorter path with fewer reflections along the way means that the minimum energy cost of producing a signal that will be readable by a receiver a certain distance
15 away from the signal generator producing the signal will be lower.

Any combination of means and method suitable for anchoring the apparatus to a tubular known to a person skilled in the art may be used for the purpose. As these combinations of means and methods for anchoring the apparatus to a tubular are known, they will not be discussed in detail in this text, nor explained or shown in detail in the embodiment descriptions.

20 The apparatus may further comprise at least one signal receiver, for receiving acoustic signals. The signal receiver may be an accelerometer. By comprising a signal receiver, the apparatus may have increased functionality, such that it may be remotely controlled, and that it may be used to relay information from an external source to an external receiver. The apparatus comprising a receiver, placed in a first position in a borehole, may receive and relay information from a second, similar
25 apparatus placed in a second position in the borehole, to a third, similar apparatus, or to another receiver, placed in a third position.

Furthermore, the apparatus comprising a signal generator may communicate with a signal receiver located outside the bore. The apparatus comprising a signal receiver may receive signals from a signal generator located outside the bore. The signal generator and/or signal receiver located outside the bore may typically be located on a wellhead or production tree. A preferred location for the
30 signal generator and/or signal receiver located outside the bore would be at the cap surrounding a tubular end or any geometry protruding from the wellhead or production tree at a right angle relative to the axial direction of the tubular through which acoustic signals would be transferred.

The apparatus may further comprise at least one sensor and/or transmitter and/or transducer. The
35 at least one sensor and/or transmitter and/or transducer may gather information about the conditions in a borehole where the apparatus may be placed. The at least one sensor and/or transmitter

and/or transducer may be a pressure transmitter, a temperature sensor, a conductivity transducer, or other instruments that may gather information about fluid characteristics or other relevant data from the borehole.

5 The apparatus may further comprise at least one logic solver for processing data. The at least one logic solver may be used to process data, such as handling data gathered from sensors, transducers and/or transmitters, translating said data into signals more adapted for transferring by acoustic means, or handling data received from an external source.

10 The apparatus may further comprise a physical barrier, separating a first section and a second section of the apparatus. The barrier may separate a defined volume in a borehole from a non-defined volume in a borehole. The apparatus may further comprise at least two sets of instruments, at least one set of instruments placed in each section of the apparatus, a first set of instruments arranged to measure borehole conditions in the non-defined volume in the borehole and a second set of instruments arranged to measure borehole conditions in the defined volume in the borehole. Each set of instruments may comprise a sensor and/or transmitter and/or transducer, a signal generator, a logic solver, a receiver for receiving acoustic signals, and an energy source.

15 The apparatus comprising a physical barrier with at least two sets of instruments and at least one set of instruments placed on each side of the physical barrier may allow for comparing the conditions in the non-defined volume of the borehole to those of the defined volume.

20 The physical barrier may be adapted to satisfy industry requirements and/or national and international standards for the apparatus to act as a primary or secondary well barrier.

25 Furthermore, the apparatus may comprise a boundary fluid reservoir. The apparatus may be adapted to be placed in a defined volume in a borehole, and to release a boundary fluid into said defined volume. The boundary fluid reservoir may be an integrated part of the apparatus to be placed in the borehole, or it may be remotely placed comprising means for transferring boundary fluid from the remotely placed boundary fluid reservoir to the defined volume. Said means for transferring boundary fluid from the remotely placed boundary fluid reservoir to the defined volume may be a tube.

The defined volume in a borehole will typically be a region between two plugs and a tubular wall of the borehole, and will comprise one or more borehole fluids.

30 The apparatus may comprise one or more openings through which to release boundary fluid. The apparatus may further comprise one or more further openings, through which borehole fluids may flow into the apparatus to refill the boundary fluid reservoir as boundary fluid is released into the defined volume of the borehole.

The apparatus may further comprise at least one valve, such as a piston valve, for closing or open-

ing for fluid flow through the openings in the apparatus.

Furthermore, the apparatus may comprise a piston that aids in forcing boundary fluid from the boundary fluid reservoir to the defined volume. The same piston may also aid in the intake of borehole fluid into the boundary fluid reservoir. The apparatus may comprise other systems for transferring fluid from the boundary fluid reservoir to the defined volume of the borehole, such as a pump-based system or a bladder-type reservoir.

The boundary fluid may be designed and/or chosen based on specific gravity. Its specific gravity may preferably be different from that of present and/or potentially present borehole fluids in the defined volume. Potentially present borehole fluids are fluids that may occur in a borehole naturally, such as reservoir fluids from the formations surrounding the borehole, or it may be fluids that may occur in the borehole as a consequence of human activities, such as fluids that are injected directly into the well or into surrounding formations. The boundary fluid is not to be seen as a fluid covered by the term potentially occurring borehole fluid.

Furthermore, the boundary fluid may preferably be a liquid that is immiscible, or partially miscible, with liquids present and/or potentially present in the defined volume of the borehole. Two liquids are defined as partially miscible if, when two volumes of the partially miscible liquids are shaken together, a meniscus will be visible between two layers of resulting liquid, and the two layers' volumes differ from that of the two volumes originally added. Immiscible liquids will, if shaken together, result in two layers of liquid, separated by a meniscus, wherein the two volumes of the two layers are identical to the two volumes of liquids shaken.

In a volume comprising different immiscible fluids, gravitational forces will organize them by their specific gravity, with the lightest fluid in the volume's upper portion and the heaviest fluid in the volume's lowest portion. As partially miscible fluids will also form layers, the same organization will apply to partially miscible fluids too. This principle may be taken advantage of by the invention.

By introducing a boundary fluid with a specific gravity different from that of present and/or possibly occurring borehole fluids in the defined volume, gravitational forces will ensure that the boundary fluid at any time is arranged according to how its specific gravity compares to that of the other fluids present.

In a possible embodiment of the invention, the at least one sensor, transducer and/or transmitter may comprise a plurality of means of detecting fluid characteristics, wherein the means of detecting fluid characteristics may be placed in such a way as to arrange for monitoring fluids in an upper portion of the defined borehole volume. In this embodiment, a boundary fluid will be chosen that has a specific gravity lower than that of any present or potentially present borehole liquid, and higher than that of any present or potentially present borehole gas. Thus, if there is one borehole liquid and one borehole gas present in the defined volume, and the boundary fluid is added, gravi-

tational forces will ensure that the borehole gas sits atop the boundary fluid, which in turn sits atop the borehole liquid.

In a typical case where the apparatus is used, it is not known whether there is gas in the defined borehole volume, neither is it known whether there is a leak e.g. in a plug defining said volume's upper border. By using the apparatus, arranged with the means for detecting fluid characteristics covering an upper portion of said volume, it will be possible to determine if there is a gas present and if there is a leakage in the plug.

If no gas is present, and there is no leak in the plug, the fluid characteristics detected will be consistent with those of the boundary fluid.

If a gas is present and there is no leak in the plug, the boundary fluid will be displaced downwards, and the fluid characteristics of the gas will be detected.

If there is a leak in the plug, the boundary fluid will move upwards, out of the defined volume, and the fluid characteristics detected will be those of a heavier borehole liquid.

The boundary fluid may be miscible with present and/or potentially present borehole fluids. If fluid characteristics data is gathered from the fluids present in a defined volume in a well, it is possible to calculate how the characteristics should change by introducing a miscible boundary fluid with known characteristics into the defined volume. By measuring how characteristics actually does change over time after release of a miscible borehole fluid with known characteristics into a defined volume containing one or more fluids with known characteristics, and compare the measured data with calculated expectations, it will be possible to make deductions regarding the conditions in the defined volume, such as if there is a leak or if there is gas present in the defined volume.

In a second aspect, the invention relates to a method for transferring data from a borehole by means of the apparatus according to the first aspect of the invention, wherein the method comprises transferring information acoustically by use of a tubular, wherein signals are produced by the signal generator and transferred to the tubular via the means for intrusion into a tubular wall.

The method may comprise anchoring the apparatus to a tubular wall.

The method may further comprise producing acoustic signals such that the direction of their P-waves substantially approximates the axial direction of a tubular in which the apparatus is set. Furthermore, the method may comprise transferring acoustic signals via the means for intrusion into a tubular wall in such a way that the direction of the P-waves relative to the axial direction of the tubular is retained.

The method may further comprise gathering information about conditions in a borehole by use of one or more sensors, transmitter and/or transducers, and it may comprise releasing a boundary

fluid into a defined volume in a borehole.

The method may further comprise receiving acoustic information from a source.

In the following is described examples of preferred embodiments illustrated in the accompanying drawings, wherein:

- 5 Fig. 1 shows the apparatus for transferring information acoustically anchored to a tubular;
- Fig. 2 shows an enhanced view of the means for intrusion into a tubular wall intruding into a tubular wall;
- Fig. 3 shows the apparatus for transferring information acoustically in an embodiment comprising a plug, a barrier separating a first section of the apparatus from a second section and separating a non-defined volume in a borehole from a defined volume in the borehole, a boundary fluid reservoir and means for monitoring conditions both in the defined volume and in the non-defined volume; and
- 10 Fig. 4 shows a schematic illustrating how the angle of an incoming acoustic signal into a material affects the reflection and refraction of the signal from and into the material.

15 Figure 1 illustrates the apparatus 1', comprising a plug 10, anchored to a tubular wall by use of means for intrusion into a tubular wall 101'. The apparatus 1' comprises a signal generator 13', the signal generator comprising two anvils 139₁, 139₂, two bolts 137₁ and 137₂ and a coil 138. The apparatus further comprises a signal receiver 14₁, a temperature transmitter 16₁ and a pressure transmitter 15₁. Furthermore, the apparatus comprises a battery 4' and a logic solver 3. The plug

20 10 comprises two locking dogs 17₁ and 17₂, each locking dog 17₁ and 17₂ comprising a set of teeth, the set of teeth constituting the apparatus' 1' means for intrusion into a tubular wall 101'. The plug 10 further comprises a locking bolt 19, an upper pressure seal 21₁ and a lower pressure seal 21₂.

By use of the temperature transmitter 15₁ and the pressure transmitter 16₁, the apparatus 1' can

25 obtain information about conditions in the volume between the apparatus 1' and the tubular wall. The information may be processed by the logic solver 3. The processed information may then be sent as acoustic signals along the tubular wall to a remote receiver. The apparatus 1' is arranged such that the signal generator 13' may produce acoustic signals with a P-wave direction substantially approximating the axial direction of the tubular 20 at the point where the means for intrusion

30 into a tubular wall 101' intrudes into the tubular wall.

Figure 2 shows the means for intrusion into a tubular wall 101', as comprised by the apparatus 1', intruding into a tubular wall. The upper sides of the means for intrusion into a tubular wall 101' are arranged such that they are perpendicular to the axial direction of the tubular 20 upon intrusion.

The purpose of the perpendicular intrusion is to ensure a signal transfer into the tubular wall that retains the direction of the P-waves; that the P-waves of the acoustic signals retains a direction substantially approximating the axial direction of the tubular 20.

Figure 3 shows the apparatus 1 anchored to a tubular 20. The apparatus 1 comprises means for intrusion into a tubular wall 101 intruding into the tubular 20. The means for intrusion into a tubular wall 101 works as the apparatus' 1 anchoring mechanism. The apparatus 1 further comprises a signal generator 13₁, comprising a coil 137, two coils 137₁, 137₂, and two anvils 139₁, 139₂. The apparatus 1 further comprises a receiver.

Figure 3 shows the apparatus 1 for transferring information acoustically, comprising a plug 10, a barrier 9, and means for monitoring conditions (13₁-13₃, 15₁, 15₂, 16₁, 16₂) placed in a defined volume V in a borehole. The defined volume V is limited on one end by the plug 10, on the opposite end by other means not shown in the illustration, e.g. the bottom end of the borehole, and radially by a tubular 20.

The plug 10 comprises a locking bolt 19, an upper pressure seal 21₁, a lower pressure seal 21₂, and two locking dogs 17₁ and 17₂. Each locking dog comprises a set of teeth, constituting the apparatus' 1 means for intrusion into a tubular wall 101. The set of teeth intrudes into the tubular wall, where they acts as means for transferring acoustic signals from the apparatus 1 into the tubular 20, and from the tubular 20 to the apparatus 1.

The apparatus comprises a plurality of signal generators 13₁-13₃ for producing acoustic signals. The signal generators 13₁-13₃ are arranged to produce signals such that the P-waves have a direction that substantially approximates the axial direction of the tubular 20. The apparatus 1, the plug 10 and the plug's teeth, the means for intrusion into a tubular wall 101, are arranged to transfer the acoustic signals efficiently from the signal generators 13₁-13₃ into the tubular.

The apparatus 1 comprises a physical, barrier element 9. The element 9 separates a first section 1₁ from a second section 1₂ of the apparatus 1, and a non-defined volume V' in the borehole from the defined volume V.

The first section 1₁ of the apparatus 1 comprises a battery 4', for providing power to any parts on the first section 1₁ of the apparatus 1 requiring energy. The first section 1₁ further comprises a logic solver 3', for processing data, a receiver 14₂, for receiving acoustic data, the signal generator 13₃, for generating acoustic signals, a temperature transmitter 16₂, for monitoring temperature in the non-defined volume V', and a pressure transmitter 15₂, for monitoring pressure in the non-defined volume V'.

In the second section 1₂ of the apparatus 1, the apparatus further comprises a boundary fluid reservoir 6, and an actuator 18 that controls a piston valve 8. Furthermore, the second section 1₂ comprises holes 2₁, 2₂, 7₁ and 7₂. If the piston valve is open, the holes 2₂ and 7₂ will be open,

which will allow for fluid to flow into and out from the boundary fluid reservoir 6. In a typical situation, where an immiscible boundary fluid has a lower specific gravity than the borehole fluid present in the borehole surrounding the apparatus 1, and the piston valve is open, gravitational forces will make the heavier borehole fluid flow into the boundary fluid reservoir 6 through holes 7₁ and 7₂, and displace the lighter boundary fluid from the boundary fluid reservoir 6 into the borehole through holes 2₂ and 2₁.

The apparatus' 1 second section 1₂ further comprises a range of sensors 5₁ – 5₁₀, arranged to monitor fluid characteristics in a portion of the defined volume V, and a battery pack 4, comprising five batteries, to provide energy to the sensors 5₁ – 5₁₀ and any other parts on the second section 1₂ of the apparatus 1 that requires energy.

Furthermore, the second section 1₂ of the apparatus 1 comprises a temperature transmitter 16₁, for monitoring temperature in the defined volume, and a pressure transmitter 15₁, for monitoring pressure in the defined volume. The second section 1₂ of the apparatus 1 further comprises a logic solver 3, for processing data.

The second section 1₂ of the apparatus 1 further comprises signal generators 13₁-13₂ for generating acoustic signals, and receiver 14₁ for receiving acoustic data. By use of one or more the signal generators 13₁-13₂ and the receiver 14₁, and the signal generator 13₃ and the receiver 14₂, the two sections of the apparatus 1 can communicate with each other. The signal generators 13₁-13₃ and the receivers 14₁-14₂ further facilitates for communication to and/or from the apparatus 1 to and/or from other sources.

Figure 4 illustrates how an acoustic signal may propagate in a material. Arrow B_I represents an incident beam, an acoustic signal directed towards a left border 99 of a tubular wall. Angle A_I is the angle of the incident beam B_I relative to the left border 99 of the tubular wall. B' represents a reflected signal, B_{RP} a refracted P-wave, B_{RS} a refracted S-wave, and A_R an angle of the refracted P-wave of the acoustic signal. By reducing the incident beam angle A_I, the angle of the refracted P-wave A_R will be reduced. Reduction of the angle of the refracted P-wave A_R will allow for a more energy efficient route of transport for the acoustic signal.

By having means for intrusion into a tubular wall 101' through which acoustic signal is transferred into a tubular 20 that are arranged with an upper side approximately perpendicular to the axial direction of the tubular, the acoustic signals may have an incident angle A_I of approximately 0°, and thus a refracted P-wave angle A_R of approximately 0°.

It should be noted that the above-mentioned embodiments illustrate rather than limit the invention, and that those skilled in the art will be able to design many alternative embodiments without departing from the scope of the appended claims. In the claims, any reference signs placed between parentheses shall not be construed as limiting the claim. Use of the verb "comprise" and its conju-

gations does not exclude the presence of elements or steps other than those stated in a claim. The article "a" or "an" preceding an element does not exclude the presence of a plurality of such elements. It should also be noted that the various features in the figures are not necessarily drawn to scale.

C l a i m s

1. Apparatus (1, 1') for transferring information acoustically via a tubular (20), the apparatus (1, 1') comprising:
 - at least one signal generator (13₁-13₃);
 - 5 - at least one energy source (4, 4'); and
 - means for intrusion into a tubular wall (101, 101') at a desired location, wherein
 - the at least one signal generator (13₁-13₃, 13') is arranged to generate signals with a P-wave direction substantially approximating the axial direction of said tubular (20) at said
 - 10 desired location; and wherein
 - the means for intrusion into a tubular wall (101, 101') are adapted for transferring acoustic signals from the apparatus (1, 1') into the tubular (20),

c h a r a c t e r i s e d i n t h a t t h e a p p a r a t u s (1 , 1 ') f u r t h e r c o m p r i s e s a m e c h a n i c a l p l u g (1 0) , t h e p l u g c o m p r i s i n g f a s t e n i n g m e a n s f o r a n c h o r i n g i n t o a t u b u l a r w a l l (1 0 1 , 1 0 1 ') , w h e r e i n t h e p l u g s f a s t e n i n g m e a n s (1 0 1 , 1 0 1 ') c o n s t i t u t e s t h e a p p a r a t u s ' (1) m e a n s f o r i n t r u s i o n i n t o a t u b u l a r w a l l (1 0 1 , 1 0 1 ') .
2. The apparatus (1, 1') according to claim 1, wherein the means for intrusion into a tubular wall (101, 101') are arranged such that at least one of the sides of the means for intrusion into a tubular wall (101, 101') upon intruding into a tubular wall are substantially perpendicular to the axial direction of the tubular (20) at the point of intrusion.
3. The apparatus (1, 1') according to claim 1 or 2, wherein the mechanical plug (10) is a barrier plug (10).
4. The apparatus (1, 1') according to any one of the previous claims, wherein the apparatus (1, 1') comprises at least one sensor, transducer and/or transmitter (5₁-5₁₀, 15₁, 15₂, 16₁, 16₂) for measuring conditions in a well, such as temperature and pressure.
5. The apparatus (1, 1') according to any one of the previous claims, wherein the apparatus (1, 1') comprises at least one signal receiver (14₁, 14₂), for receiving acoustic signals.
6. The apparatus (1, 1') according to any one of the previous claims, wherein the apparatus (1, 1') comprises at least one logic solver (3, 3'), for processing data.
7. The apparatus (1, 1') according to any one of the previous claims, wherein the apparatus (1, 1') comprises at least two sets of instruments, each set comprising at least one signal generator (13₁-13₃, 13'), at least one sensor, transmitter or transducer (5₁-5₁₀, 15₁, 15₂, 16₁, 16₂), at least one energy source (4, 4'), at least one logic solver (3, 3') and at least one receiver (14₁, 14₂), wherein at least one set is positioned on each side of a physical

barrier (9), for measuring conditions on each side of the barrier and communicating through the barrier.

8. The apparatus (1, 1') according to any one of the previous claims, comprising a reservoir (6) for storing a boundary fluid.
- 5 9. The apparatus (1, 1') according to claim 8, wherein the apparatus is adapted to release the boundary fluid into a defined volume (V) in a borehole in which the apparatus (1, 1') is placed.
10. The apparatus (1, 1') according to any one of the previous claims, comprising a plurality of sensors, transducers and/or transmitters (5₁-5₁₀) arranged for monitoring fluid characteristics in a portion of a defined volume (V) in a borehole.
10
11. Method for transferring information acoustically via a tubular (20) by means of an apparatus (1, 1') according to claim 1, the method comprising the steps of:
 - establishing an intrusion into the tubular (20) wall by use of the means for intrusion into a tubular wall (101, 101') at a desired location;
 - 15 - generating acoustic signals by use of the at least one signal generator (13₁-13₃, 13');
and
 - transferring generated acoustic signals from the at least one signal generator (13₁-13₃, 13') into the tubular (20) wall via the means for intrusion into the tubular wall (101, 101'),
the method characterised in that the method further includes the
20 following step:
 - generating acoustic signals with a P-wave direction that substantially approximates the axial direction of the tubular (20) at said desired location.

P a t e n t k r a v

1. Apparat (1, 1') for å overføre informasjon akustisk via et rør (20), idet apparatet (1, 1') omfatter:
 - minst én signalgenerator (13₁–13₃);
 - 5 - minst én energikilde (4, 4'); og
 - midler for inntrengning inn i en rørvegg (101, 101') ved et ønsket punkt, hvor
 - den minst ene signalgeneratoren (13₁–13₃, 13') er innrettet for å generere signaler med en P-bølgeretning som hovedsakelig approksimerer den aksiale retningen til nevnte rør
 - 10 (20) ved nevnte ønskede punkt; og hvor
 - midlene for inntrengning inn i en rørvegg (101, 101') er tilpasset for å overføre akustiske signaler fra apparatet (1, 1') inn i røret (20),
 - k a r a k t e r i s e r t v e d at apparatet (1, 1') videre omfatter en mekanisk plugg (10), idet pluggen omfatter festemidler for å festes i en rørvegg (101, 101'), hvor
 - 15 pluggens festemidler (101, 101') utgjør apparatets (1) midler for inntrengning inn i en rørvegg (101, 101').
2. Apparatet (1, 1') ifølge krav 1, hvor midlene for inntrengning inn i en rørvegg (101, 101') er innrettet slik at minst én av sidene til midlene for inntrengning inn i en rørvegg (101, 101') ved inntrengning inn i en rørvegg er hovedsakelig loddrett i forhold til den aksiale
- 20 retningen til røret (20) ved punktet for inntrengning.
3. Apparatet (1, 1') ifølge krav 1 eller 2, hvor den mekaniske pluggen (10) er en barriereplugg (10).
4. Apparatet (1, 1') ifølge hvilket som helst av de foregående kravene, hvor apparatet (1, 1') omfatter minst én sensor, transduser og/eller transmitter (5₁–5₁₀, 15₁, 15₂, 16₁, 16₂) for å
- 25 måle tilstander i en brønn, slik som temperatur og trykk.
5. Apparatet (1, 1') ifølge hvilket som helst av de foregående kravene, hvor apparatet (1, 1') omfatter minst én signalmottaker (14₁, 14₂) for å motta akustiske signaler.
6. Apparatet (1, 1') ifølge hvilket som helst av de foregående kravene, hvor apparatet (1, 1') omfatter minst én logikkløser (3, 3') for å behandle data.
- 30 7. Apparatet (1, 1') ifølge hvilket som helst av de foregående kravene, hvor apparatet (1, 1') omfatter minst to sett instrumenter, idet hvert sett omfatter minst én signalgenerator (13₁–13₃, 13'), minst én sensor, transmitter eller transduser (5₁–5₁₀, 15₁, 15₂, 16₁, 16₂), minst én energikilde (4, 4'), minst én logikkløser (3, 3') og minst én mottaker (14₁, 14₂), hvor
- 35 minst ett sett er posisjonert på hver side av en fysisk barriere (9) for å måle tilstander på hver side av barrieren og kommunisere gjennom barrieren.

8. Apparatet (1, 1') ifølge hvilket som helst av de foregående kravene, som omfatter et reservoar (6) for å oppbevare et grensefluid.
9. Apparatet (1, 1') ifølge krav 8, hvor apparatet er tilpasset til å frigi grensefluidet inn i et definert volum (V) i et borehull som apparatet (1, 1') er plassert i.
- 5 10. Apparatet (1, 1') ifølge hvilket som helst av de foregående kravene, som omfatter en flershet av sensorer, transdusere og/eller transmittere (5₁–5₁₀) innrettet for å overvåke fluidkjenntegn i en del av et definert volum (V) i et borehull.
11. Fremgangsmåte for å overføre informasjon akustisk via et rør (20) ved bruk av et apparat (1, 1') ifølge krav 1, idet fremgangsmåten omfatter trinnene å:
- 10 - etablere en inntrengning inn i veggen til røret (20) ved bruk av midlene for inntrengning inn i en rørvegg (101, 101') ved et ønsket punkt;
- generere akustiske signaler ved bruk av den minst ene signalgeneratoren (13₁–13₃, 13');
og
- 15 - overføre genererte akustiske signaler fra den minst ene signalgeneratoren (13₁–13₃, 13') inn i veggen til røret (20) via midlene for inntrengning inn i rørveggen (101, 101'), idet fremgangsmåten er k a r a k t e r i s e r t v e d at fremgangsmåten videre inkluderer følgende trinn:
- 20 - generere akustiske signaler med en P-bølgeretning som hovedsakelig approksimerer den aksiale retningen til røret (20) ved nevnte ønskede punkt.

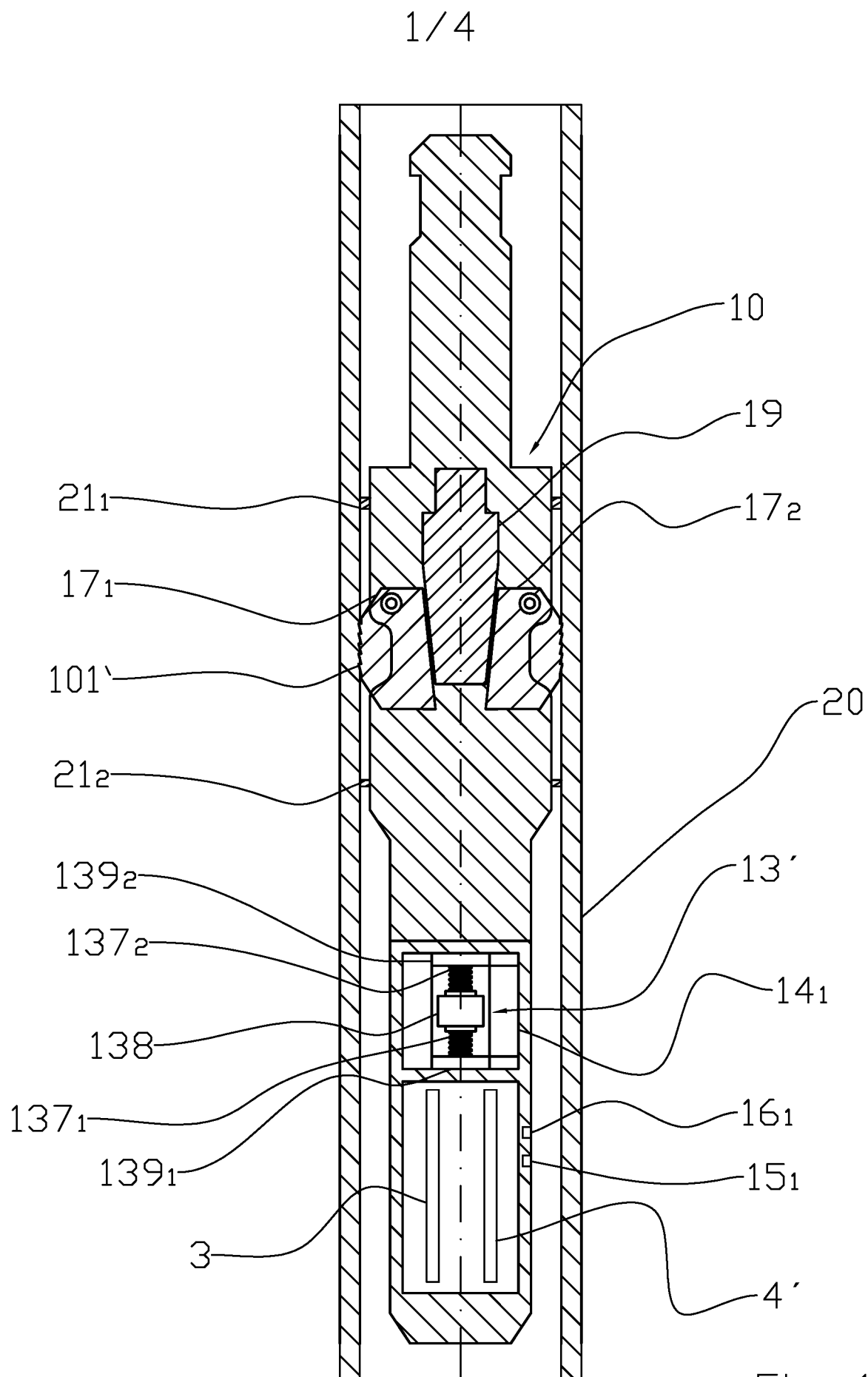

Fig. 1

2/4

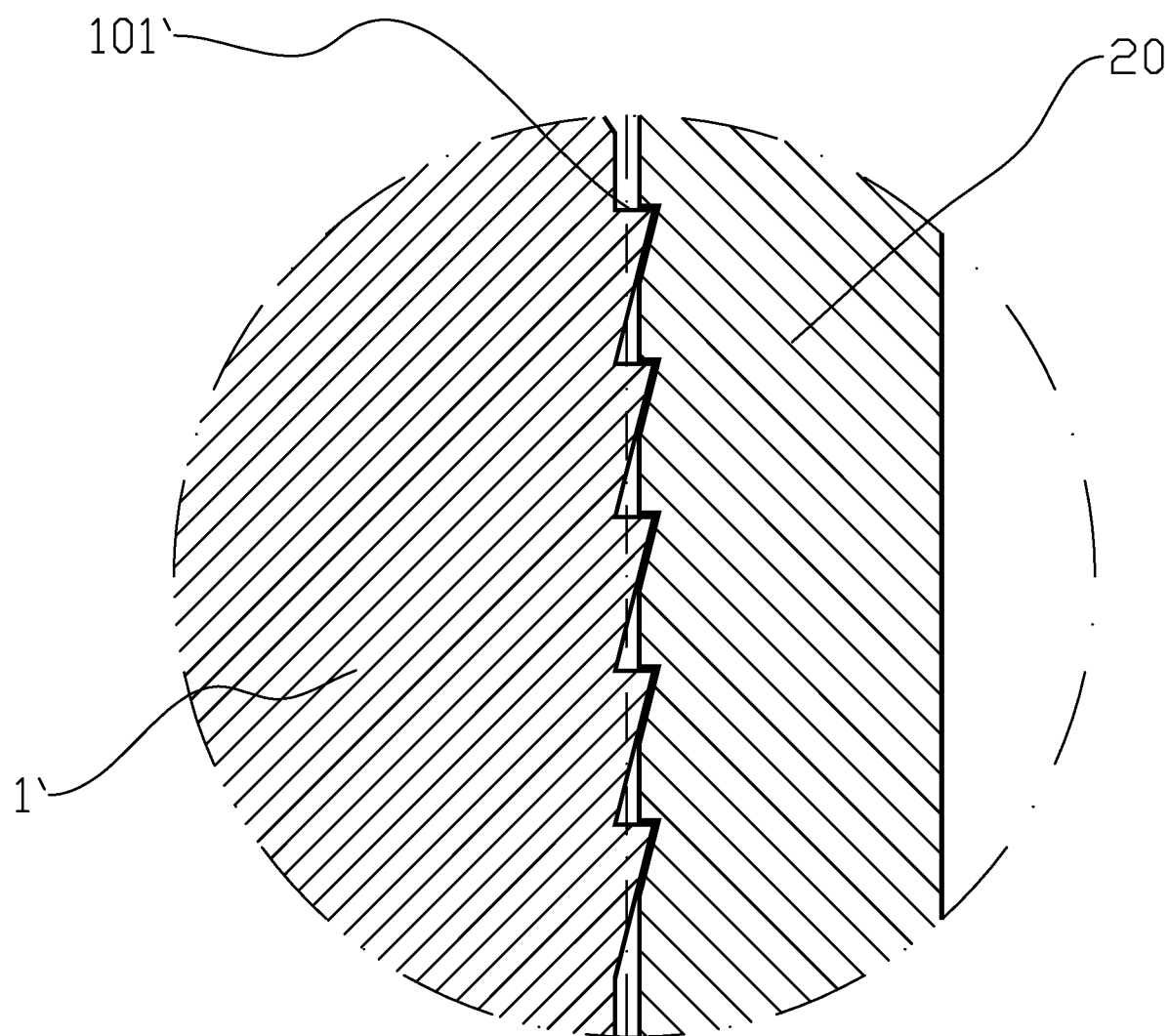

Fig. 2

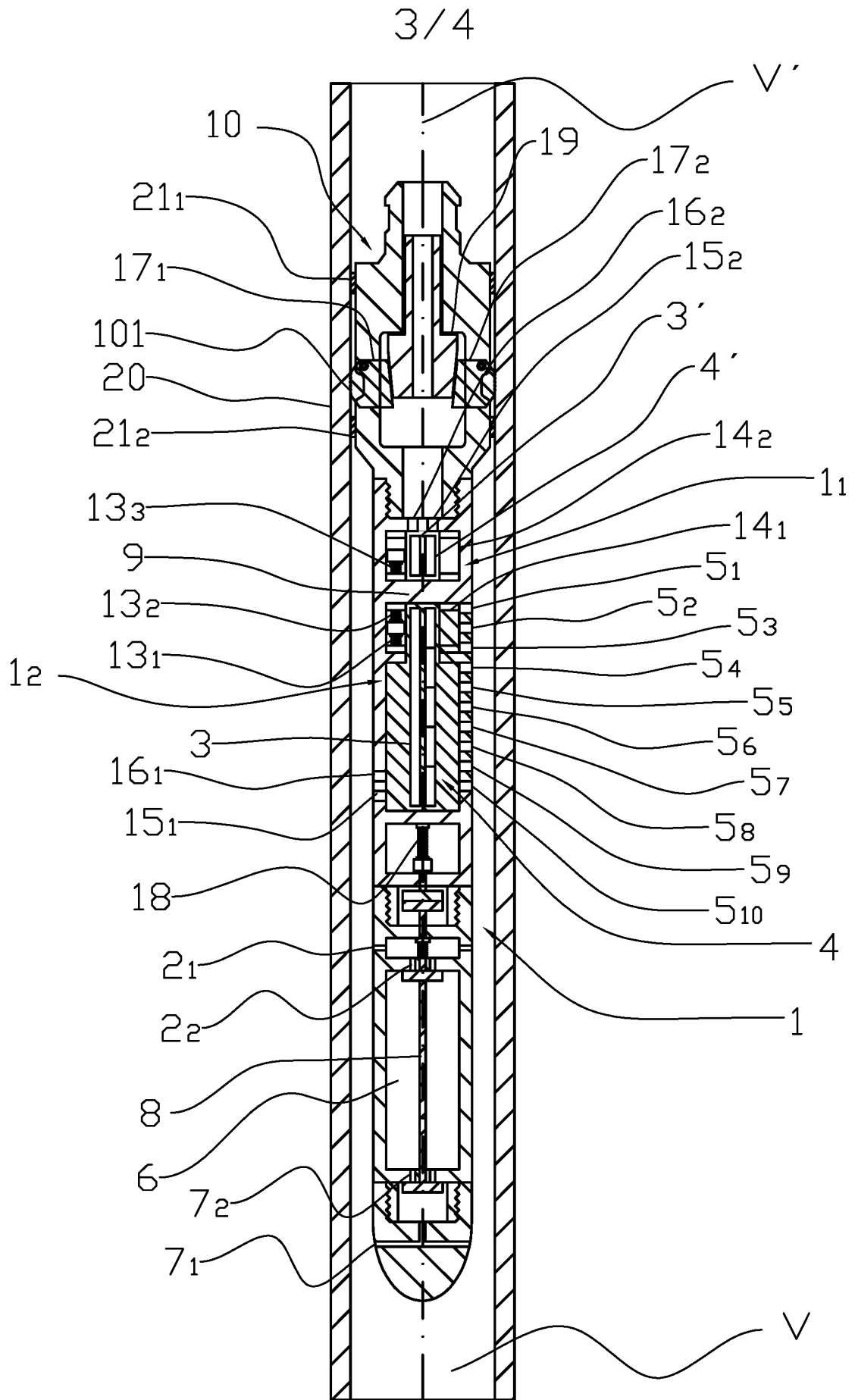

Fig. 3

4/4

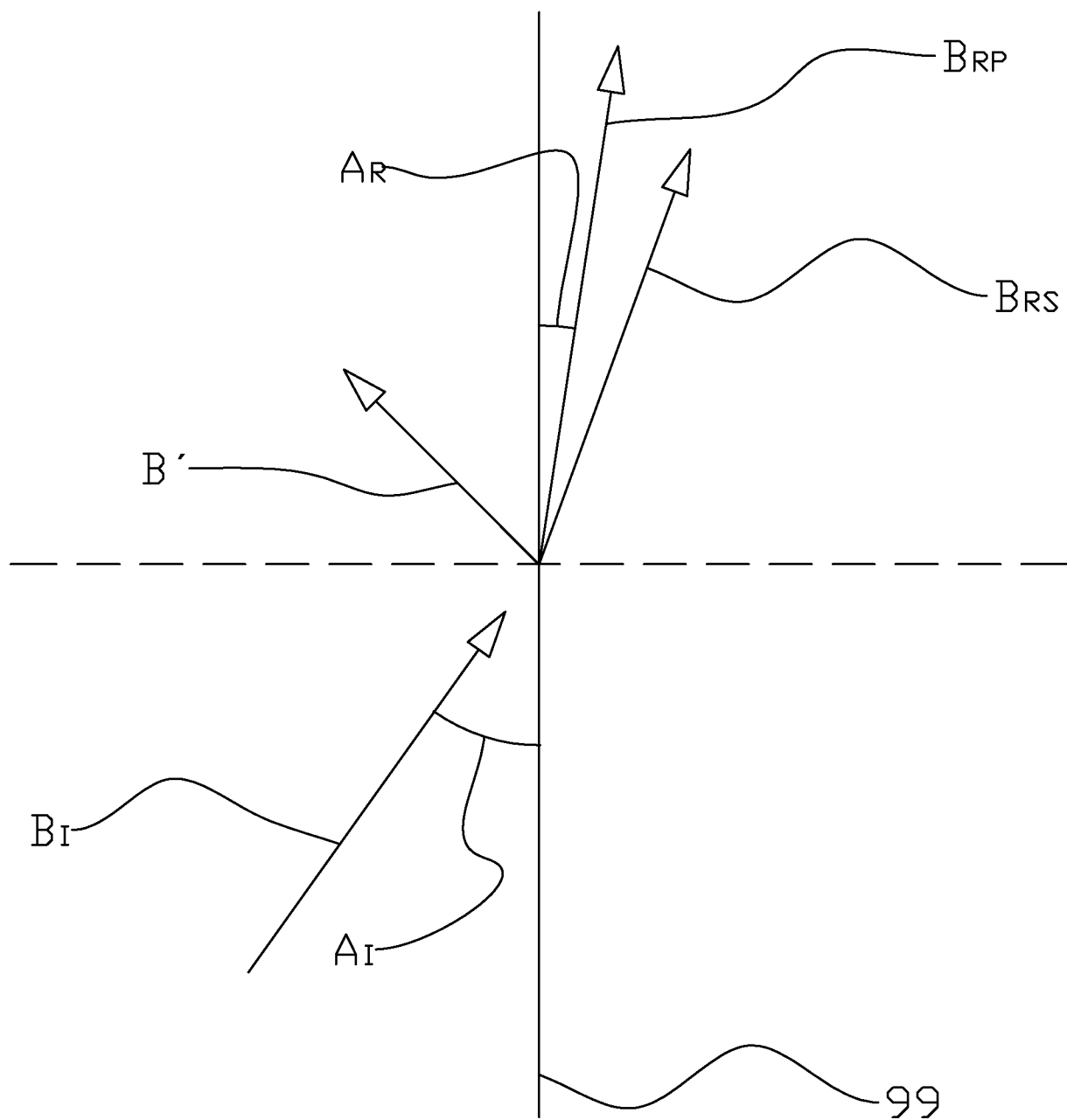

Fig. 4