

(12) **UK Patent Application** (19) **GB** (11) **2 302 058** (13) **A**

(43) Date of A Publication **08.01.1997**

(21) Application No **9511878.2**

(22) Date of Filing **12.06.1995**

(71) Applicant(s)
Black & Decker Inc.

(Incorporated in USA - Delaware)

**Drummond Plaza Office Park, 1423 Kirkwood
Highway, Newark, Delaware 19711,
United States of America**

(72) Inventor(s)
Daniel Bone

(74) Agent and/or Address for Service
Darrin Shaya et al
**Black & Decker, Patent Department, 177 Walsall Road,
BIRMINGHAM, B42 1BP, United Kingdom**

(51) INT CL⁶
B27B 9/02

(52) UK CL (Edition O)
B5L LAP L102

(56) Documents Cited
GB 2196898 A **US 4221051 A**

(58) Field of Search
UK CL (Edition N) **B5L**
INT CL⁶ **B27B 9/02**

(54) **Hand-held circular saw.**

(57) The saw includes a base plate (24) comprising first and second plates (26, 28). The plates (26, 28) pivot about mutually orthogonal axes to adjust the depth of cut and bevel angle of the saw respectively. Adjustment of the angles of the plates (26, 28) is affected by means of rotatable actuators (34, 36). Each actuator (34, 36) comprises a rack and pinion mechanism and a lockable clamp (44, 42). Each actuator (34, 36) is operable by only one hand of the user.

The saw includes a motor (6) whose axis of rotation is in line with the plane of rotation of the saw blade (10). A handle (18) extends between a region adjacent the saw blade (10) and the motor (2).

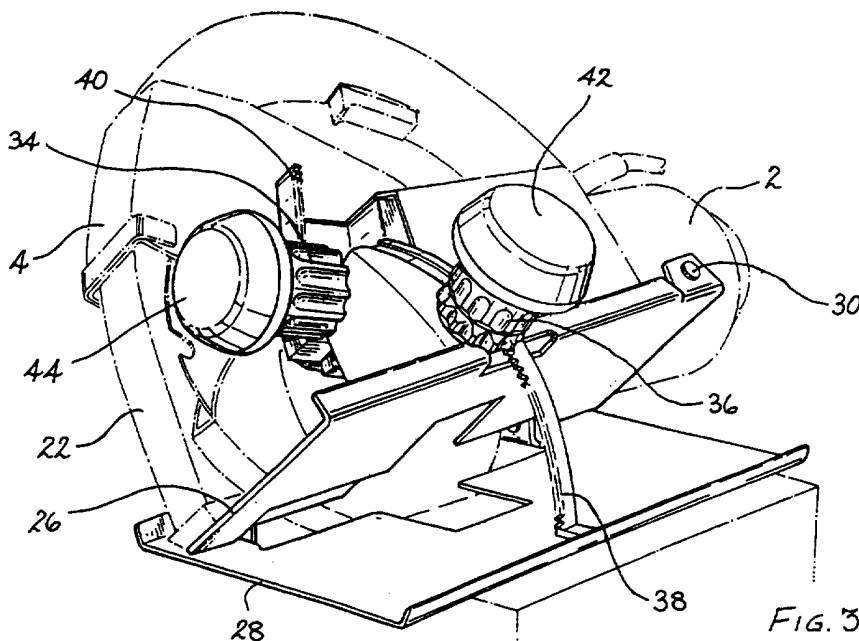

GB 2 302 058 A

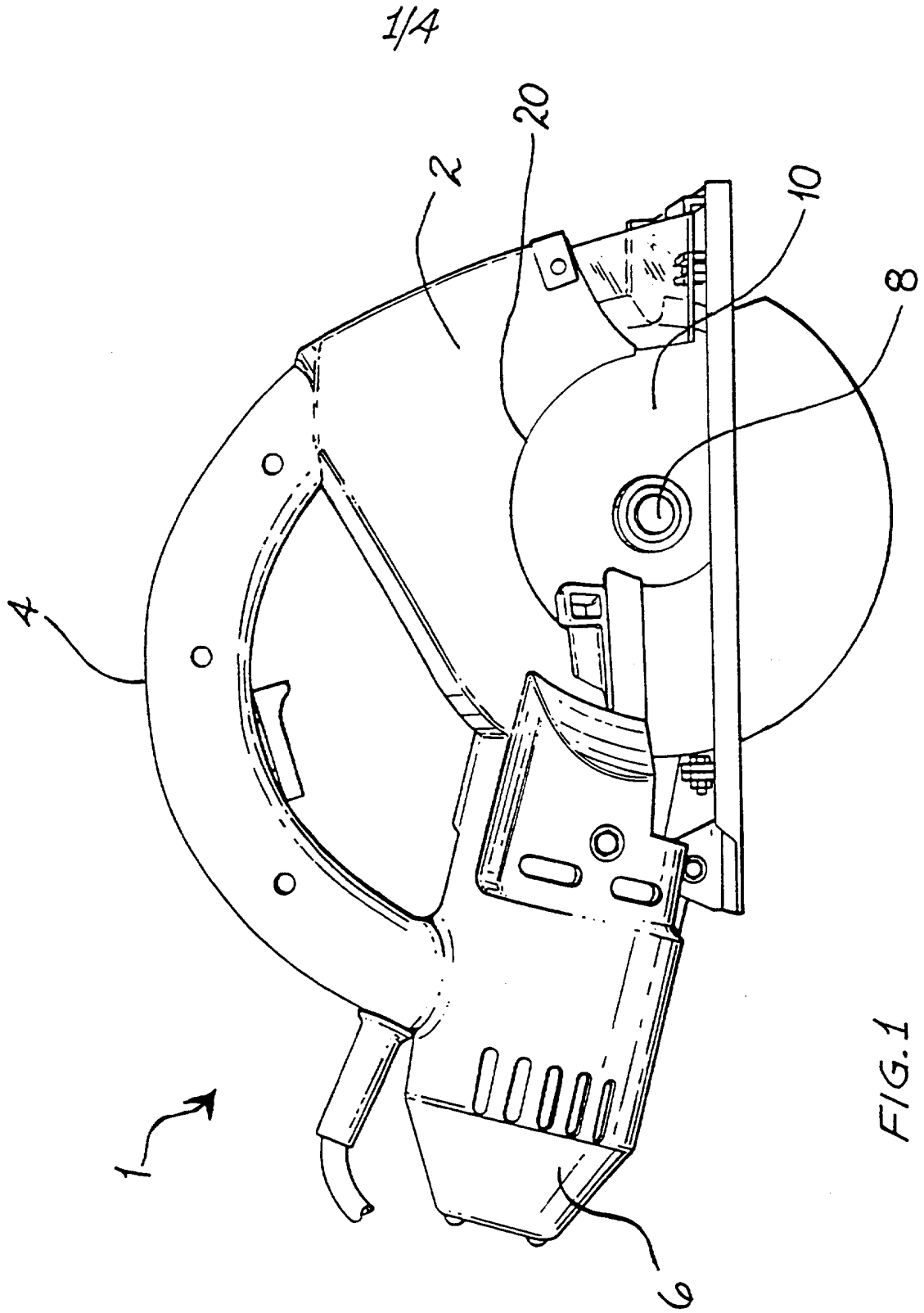

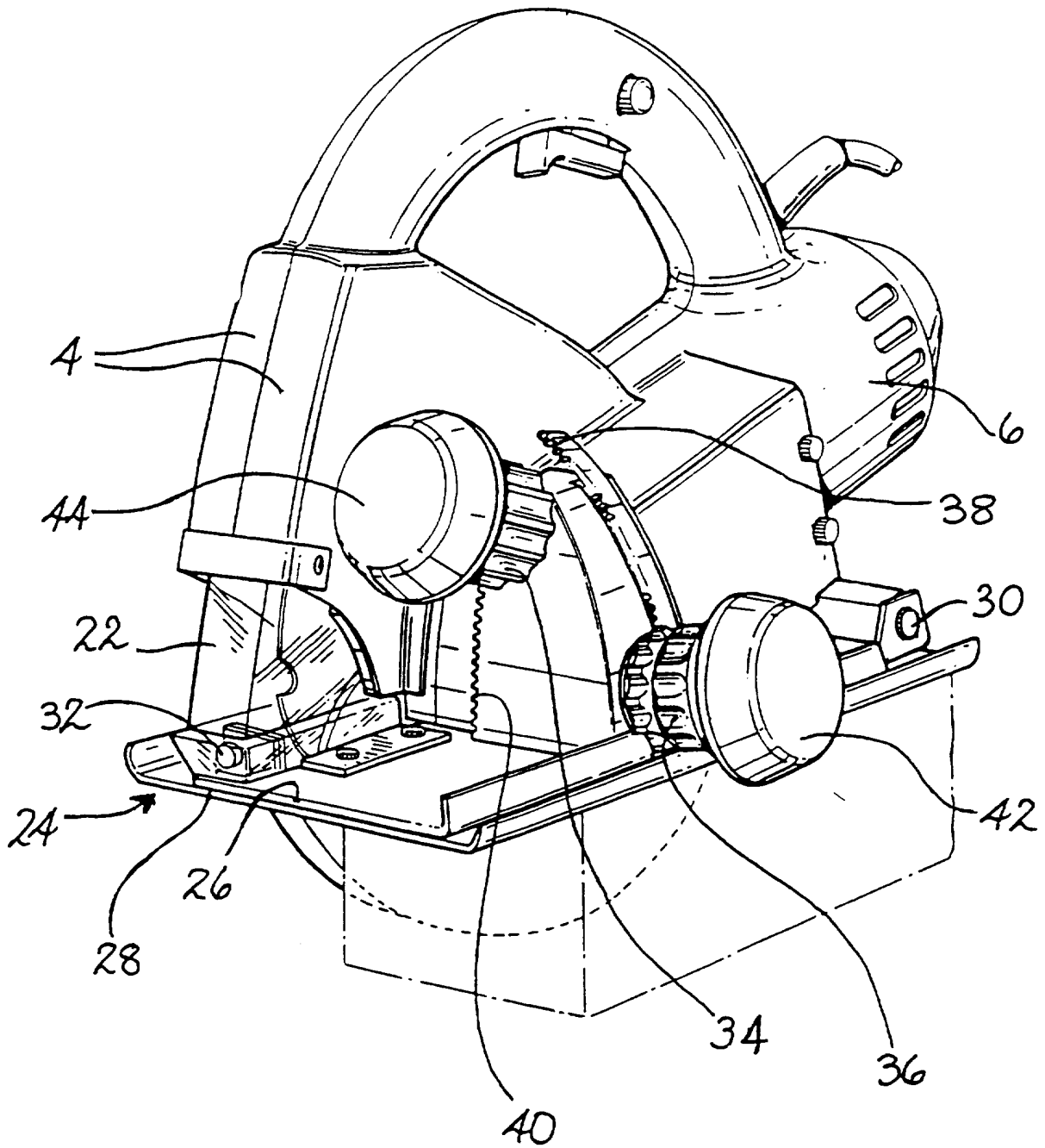

FIG. 2

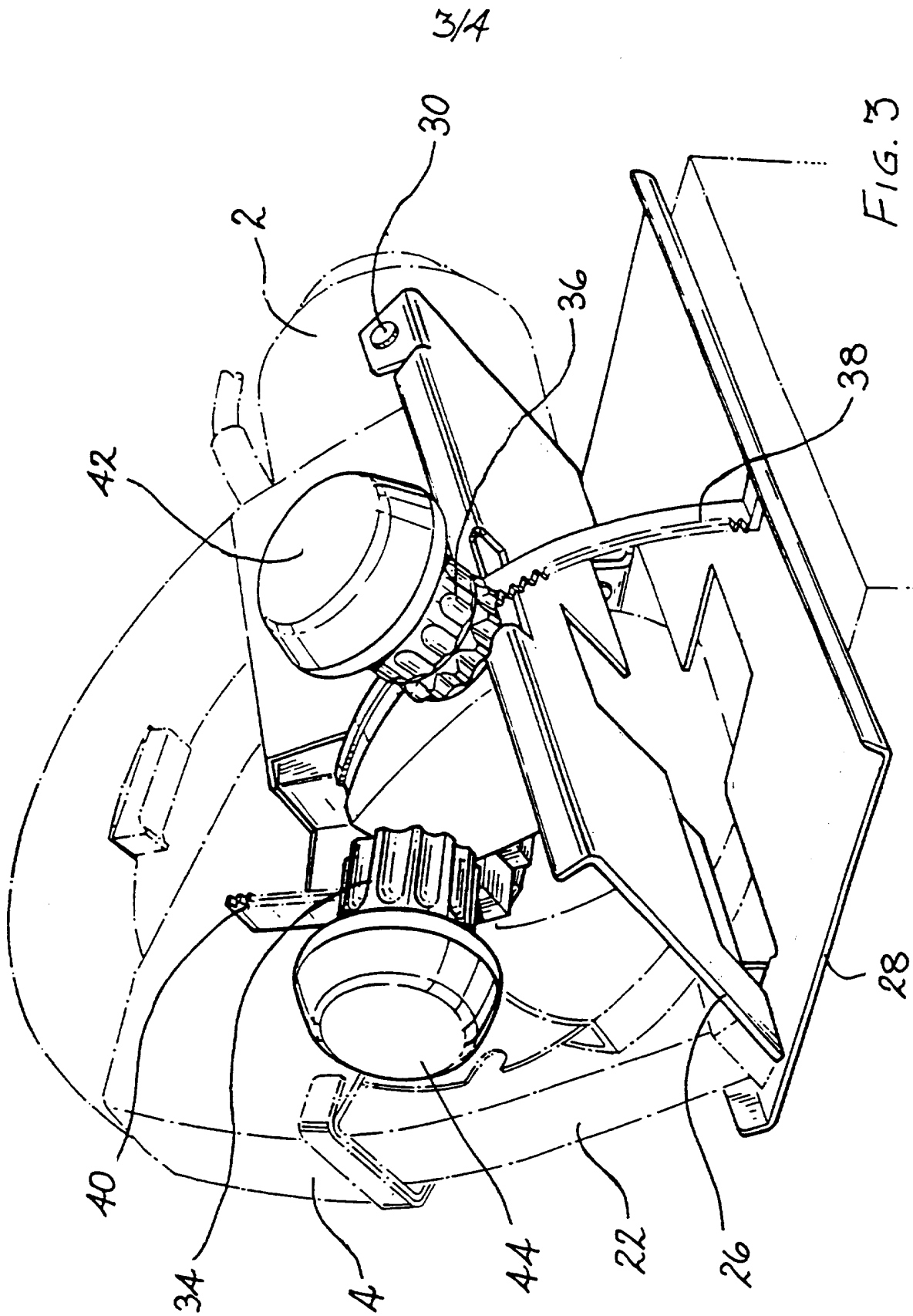

FIG. 3

3/4

42

2

30

36

38

40

34

4

44

22

26

28

4/4

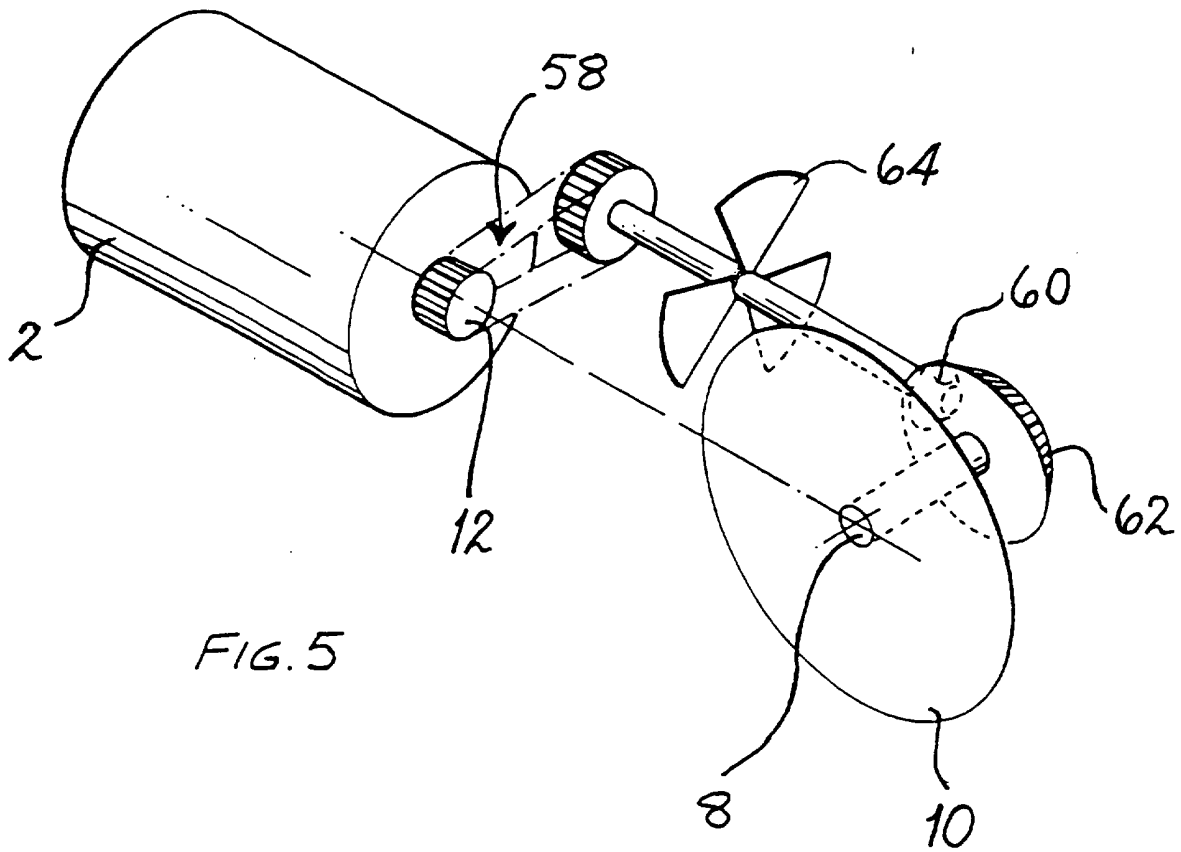
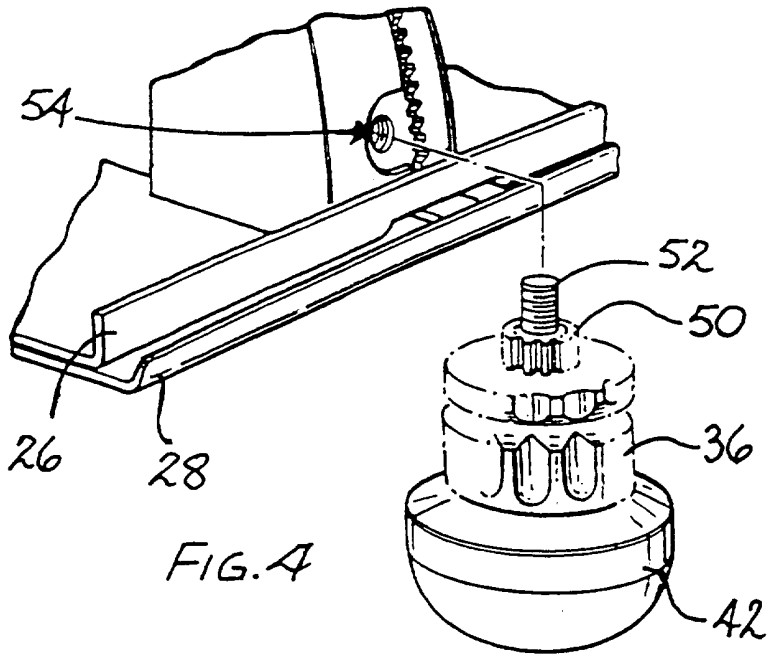

HAND-HELD CIRCULAR SAW

The present invention relates to a hand-held circular saw and has particular, although not exclusive relevance to a circular saw as maybe used by professional workmen for cutting wood.

- 5 Conventional circular saws comprise an electric motor having an output spindle which is directly coupled to a circular saw blade. When the electric motor is energised the circular saw blade rotates and this may be pushed into engagement with a workpiece to be cut. The circular saw also comprises a blade guard which generally
- 10 surrounds the blade such that the user is not in danger of either being cut by the blade or by being in the path of debris by the workpiece during use of the blade. The blade is positioned relative to the workpiece by means of a shoe or base plate connected to the body of the circular saw.
- 15 In use of the device the user will rest the base plate against the workpiece and push this along the workpiece such that the saw blade bites into the workpiece thereby achieving cutting.

In such conventional saw blades it is known to provide adjustment means whereby the angle of the plane of the blade with respect to

20 the plane of the workpiece (known in the art as bevel) maybe altered. Such adjustment means generally comprises a pivot point on the base plate and a release mechanism. When the release

- mechanism is undone the base plate may pivot about the point thereby to alter the bevel angle of the saw blade. Such release mechanisms however, tend to be difficult to operate because the user needs to have two hands free. One hand needs to release the
- 5 clamping mechanism which prevents pivoting of the base plate and the other hand of the user then needs to move the base plate about the pivot point to the desired angular position. Such complicated movements add time to the sawing operation and are also inconvenient for the user.
- 10 In such known saws there is generally also a mechanism for adjusting the depth of cut of the saw blade. This mechanism also includes a pivot point on the base plate whereby the amount of the saw blade which protrudes beyond the base plate onto the workpiece is altered. The mechanism for achieving this alteration or depth of
- 15 cut is similar to that described above for altering bevel angle in that a releasable catch needs to be undone in order to enable the user then to move the saw blade about the pivot point on the base plate in order to adjust the depth of cut. This too requires two handed operation and is generally inconvenient for the user.
- 20 Conventional circular saws also tend to be rather cumbersome to use because the axis of rotation of the motor for driving the saw blade is orthogonal to the plane of rotation of the saw blade itself. This means that when in use the saw blade is not particularly well balanced about its mid-point. Generally the handle for operating the

saw blade is about the mid-point and so a degree of imbalance occurs. Furthermore, because the motor is arranged orthogonal to the plane of rotation of the saw blade the handle for using the circular saw tends to be rather small and therefore can often present
5 problems with grip for the user.

It is therefore an object of the present invention to provide a circular saw which offers certain advantages to the user which will become apparent here below.

According to the present invention there is provided a hand-held circular saw comprising a housing accommodating a motor for driving a saw blade, a base plate pivotably attached to the housing for adjusting the depth of cut or the angle of cut of the saw blade;
5 and means for controlling the angle of the base plate relative to the housing, wherein the control means comprising a rotatable actuator designed to be operated with one hand which, when rotated, drives the base plate relative to the housing. This provides the advantage that the user is able to adjust the attitude of the base plate with
10 respect to the housing with only one hand thereby making adjustment of the saw blade easy during use.

Preferably the actuator is lockable to prevent said relative movement. Additionally or alternatively the actuator includes a clamp effective to inhibit rotation of the actuator. This provides the
15 advantage that in a single actuator unit a locking facility is available without the need for separate such features.

maintained at the same attitude with respect to the rest of the users arm and therefore a more comfortable user position is obtained.

The present invention will now be described by way of example only and with reference to the following drawings of which;

5 Figure 1 shows a side view of a circular saw according to the present invention;

Figure 2 shows a side view of a circular saw according to the present invention from the opposite side to that of figure 1;

10 Figure 3 shows a front view of the bevelling arrangement with a minimum depth of cut for a circular saw in accordance with the present invention;

Figure 4 illustrates schematically a partially dismantled actuator in accordance with the present invention and;

15 Figure 5 shows a schematic view of the motor and drive mechanism for a circular saw in accordance with the present invention.

Referring firstly to figures 1 and 2, it will be seen that a circular saw shown generally as 1 in accordance with the present invention comprises a housing (2), in this case clamshell arrangement (4) within which housing is mounted a motor (6) effective to drive a
20 drive spindle (8) upon which a circular saw blade (10) may be

an output which is a rotatable shaft (12) which shaft (12) lies in the plane of rotation of the saw blade (10) mounted on the drive spindle (8). This "in-line" arrangement of the motor with the rotated saw blade means that the circular saw in accordance with the present invention is well-balanced in use. Furthermore, this means that the clamshell (4) may be formed from only two portions (14, 16) which are brought together to form the single clamshell unit (4) within which are encased the motor (6), the rotatable shaft (12) and the drive spindle (10). By enabling such a clamshell arrangement to occur, this in-line motor and saw blade system means that construction of the saw is generally cheaper than with conventional units wherein more than 2 half portions are necessary to encapsulate all the working mechanisms of the device.

Furthermore, this in-line arrangement permits the clamshell (4) to define a handle (18) which extends from the region adjacent to the motor (6) to a region adjacent to the spindle (8), the handle extending parallel to the plane of rotation of the saw blade (10). The handle therefore is of much longer length than with conventional circular saws wherein the motor is adjacent the rotating saw blade, this providing a great deal of stability for the user of the circular saw. As can be seen particularly from figures 1 and 2 the handle (18) forms an arc. This means that, regardless of the attitude of the circular saw to the work piece when the depth of cut is altered the user may maintain the same attitude of his wrist or hand regardless of the attitude of the saw for the selected depth of cut.

As can be seen from figure 1 the clamshell (4) is formed so as to define a blade guard (20). Forming the guard from the clamshell itself obviates the need to have a separate blade guard. Furthermore, the blade guard includes a window (22) formed of transparent plastics material. This enables the user of the saw to be able to accurately see where on the work piece the sawblade (10) will cut.

Referring now particularly to figures 2 and 3 it can be seen that the saw (2) includes a base plate (24) for adjusting the depth of cut and the bevel angle of the saw (2). The base plate (24) comprises a first plate (26) for adjusting the depth of cut and a second plate (28) for adjusting the bevel angle. The first plate (26) is pivotally connected to the housing (2) via pivot point (30) and the second plate (28) is pivotally connected to the first plate (26) via a pivot point (32).

It can be seen that the axes of the respective pivot (30 and 32) are substantially perpendicular. This allows the first pivot (30) and its corresponding plate (26) to enable depth of cut to be adjusted and the second pivot (32) and its corresponding plate (28) to enable bevel angle to be adjusted.

It can be seen from the drawings that the adjustment of the angular position of the component plates (26, 28) of the base plate (24) are controlled by means of respective actuators (34, 36). The actuators in this example comprise a rotatable pinion (or tooth gear)

mechanism which co-operates with a respective rack mechanism.

Rotation of the actuator causes relative movement between itself and its respective rack thereby to move either of the plates (26 or 28) in order to adjust their angular position with respect to the housing (2).

5 For example figure 3 illustrates the maximum bevel angle being achieved by actuator (36) causing its rack (38) to be fully extended whereas the actuator (34) controlling the depth of cut is at the very other extreme of its rack (40) travel thereby achieving maximum
10 depth of cut (because the saw blade (10) protrudes through the base plate (24) to its maximum possible depth).

Formed co-axial with each of the actuators (34 and 36) and having a screw thread passing all the way therethrough are respective clamps (42 and 44). Each of the clamps is rotatable to either prevent further rotation of the actuator or release the actuator for rotation. This
15 operation is achieved because the screw thread of the respective clamp (42 or 44) tends to draw the clamp towards the actuator and restrain it between the clamp and the respective mount (46, 48) on which the actuator is held.

Figure 4 shows more clearly the actuator and clamp mechanism. It
20 can be seen that the actuator (36) carries a toothed ring (pinion, 50) and through the centre axis of the actuator passes a screw thread (52) of the clamp (42), which screw thread engages with a corresponding screw thread hole (54) in the mount (46). When the clamp is not fully tightened the actuator (36) may be turned thereby

to cause the teeth of the pinion (50) to engage with teeth in its respective rack (38) thereby to move the plate (28) about its pivot point (32) in order to alter the bevel angle of the saw blade (10). However, when the clamp (42) is fully tightened the actuator (36) is held between the clamp (42) and the mount (46) thereby to lock the base plate at whatever angle it is at that time.

It will be appreciated that the present actuator mechanism enables adjustment of either of the plates (26, 28) with only one hand of the user. This provides significant advantage over hitherto known circular saw adjustment mechanisms.

Considering now figure 5 it can be seen that the motor (6), which is housed within the clamshell (4), has an output which is a rotatable shaft (12). The rotatable shaft (12) co-operates with a gear mechanism. The gear mechanism includes a gear shaft (56) coupled to the rotatable shaft (12) via an electrically insulated belt (58). The end of the gear shaft (56) remote from the motor (6) carries a first bevel gear (60). It can be seen that the gear shaft (56) is axially parallel with, although displaced from, the axis of the rotatable shaft (12). The first bevel gear (60) on the gear shaft (56) co-operates with a corresponding bevel gear (62) formed on the drive spindle (8). It can also be seen that the axis of the drive spindle (8) is orthogonal to the axis of both the gear shaft (56) and the rotatable shaft (12).

It will also be seen from figure 5 that the gear shaft (12) carries a fan (64). The fan is arranged to draw air (and therefore any material caught up in the air flow such as debris from the workpiece being cut) from the end of the gear shaft (56) adjacent the saw blade (10).

5 Such drawn material may then be ejected from the saw (2) via a port (not shown) in the clamshell (4). This facility allows for dust removal and will be apparent to those skilled in the art and so not further described herein.

10 It will be understood by those skilled in the art that the housing (2) may be formed integrally with the plastics material of the clamshell (4) or both the housing (2) and the clamshell (4) maybe separate items.

15 It will be seen from the above and the enclosed drawings that in this example the rack mechanisms are contrate, but this is not imperative, as any rack mechanism will suffice.

CLAIM

- 1 A hand-held circular saw comprising a housing accommodating
a motor for driving a saw blade, a base plate pivotally attached to the
housing for adjusting the depth of cut or the angle of cut of the saw
5 blade; and means for controlling the angle of the base plate relative
to the housing, wherein the control means comprises a rotatable
actuator designed to be operated with one hand which, when rotated,
drives the base plate relative to the housing.
- 2 A hand-held circular saw according to claim 1 wherein the
10 actuator is lockable to prevent said relative movement.
- 3 A hand-held circular saw according to claim 1 or claim 2
wherein the actuator includes a clamp effective to inhibit rotation of
the actuator.
- 4 A hand-held circular saw according to claim 3 wherein the
15 clamp is tightened, to inhibit rotation of the actuator, by means of
rotation of the clamp.
- 5 A hand-held circular saw according to any one of the preceding
claims wherein the actuator includes a toothed wheel which engages
a rack to drive the base plate relative to the housing.

6 A hand-held circular saw according to claim 5 where in the
rack is mounted on the housing and the actuator is mounted on the
base plate.

7 A hand-held circular saw according to any one of the preceding
5 claims wherein a second plate is pivotally attached to the base plate,
the position of the second plate relative to the base plate being
controlled by a second rotatable actuator designed to be operated
with one hand which, when rotated, drives the second plate relative
to the base plate.

10 8 A hand-held circular saw according to claim 7, wherein the
base plate pivots relative to the housing to define the depth of cut of
the saw blade and the second plate pivots relative to the base plate to
define the angle of cut of the saw blade.

9 A hand-held circular saw according to either one of claim 7 or
15 claim 8 wherein the second rotatable actuator includes a toothed
wheel which engages a rack to drive the base plate relative to the
housing.

10 A hand-held circular saw according to any one of claim 5, 7 to
9, wherein the rack is mounted on the housing and the actuator is
20 mounted on the base plate.

11 A hand-held circular saw substantially as herein before described with reference to the accompanying drawings.

Relevant Technical Fields

- (i) UK Cl (Ed.N) B5L
- (ii) Int Cl (Ed.6) B27B 9/02

Search Examiner
R B LUCK

Date of completion of Search
15 SEPTEMBER 1995

Databases (see below)

(i) UK Patent Office collections of GB, EP, WO and US patent specifications.

Documents considered relevant following a search in respect of Claims :-
1-11

(ii)

Categories of documents

- X:** Document indicating lack of novelty or of inventive step.
- Y:** Document indicating lack of inventive step if combined with one or more other documents of the same category.
- A:** Document indicating technological background and/or state of the art.
- P:** Document published on or after the declared priority date but before the filing date of the present application.
- E:** Patent document published on or after, but with priority date earlier than, the filing date of the present application.
- &:** Member of the same patent family; corresponding document.

Category	Identity of document and relevant passages	Relevant to claim(s)
X	GB 2196898 (ROBERT BOSCH)	Claim 1 at least
X	US 4221051 (SINGER CO)	Claim 1 at least

Databases: The UK Patent Office database comprises classified collections of GB, EP, WO and US patent specifications as outlined periodically in the Official Journal (Patents). The on-line databases considered for search are also listed periodically in the Official Journal (Patents).