

[54] CONTROL VALVE

2,436,617 2/1948 Svet..... 239/416.4

[76] Inventor: Ernst Sussman, 634 Stefko Blvd., Bethlehem, Pa. 18016

Primary Examiner—Robert G. Nilson

Attorney—Sherman Levy

[22] Filed: Sept. 22, 1972

[21] Appl. No.: 291,382

Related U.S. Application Data

[62] Division of Ser. No. 151,065, June 8, 1971, Pat. No. 3,726,363.

[57] ABSTRACT

[52] U.S. Cl..... 137/556.6, 137/606, 251/345

A coolant spider assembly that serves to selectively feed coolant to the spindles of a turret type drilling machine, and wherein there is provided a valve means for controlling the flow of coolant, and wherein there is also provided a sealing arrangement for the spider assembly.

[51] Int. Cl..... F16k 19/00

[58] Field of Search..... 239/413, 416.1, 416.4; 251/340, 345; 137/606, 594, 556.6

[56] References Cited

UNITED STATES PATENTS

453,109 /1891 Dreisorner..... 251/345 X

1 Claim, 8 Drawing Figures

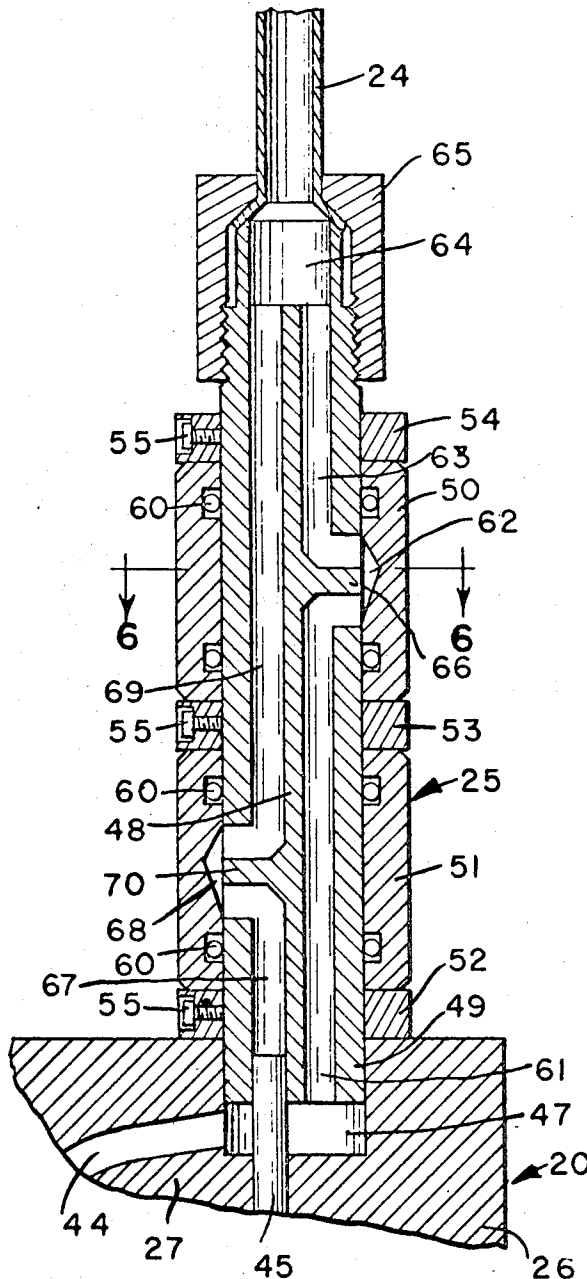

FIG. 1

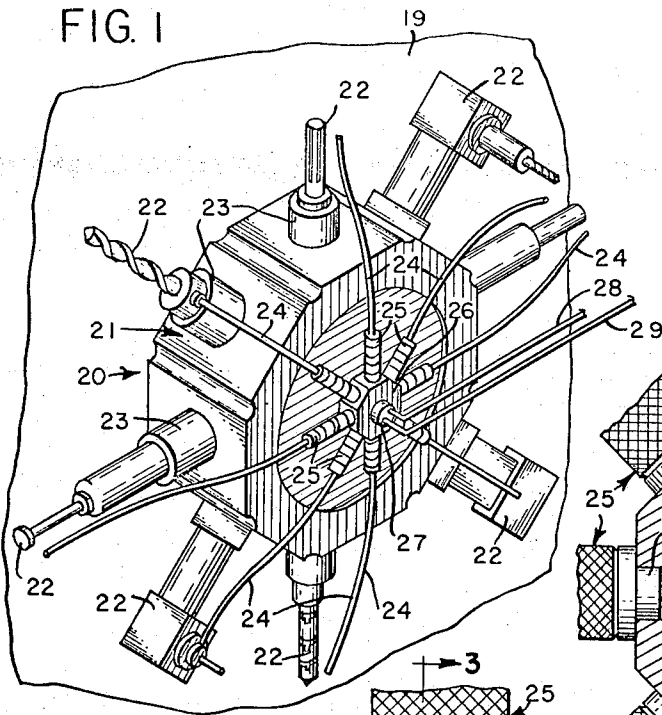

FIG. 3

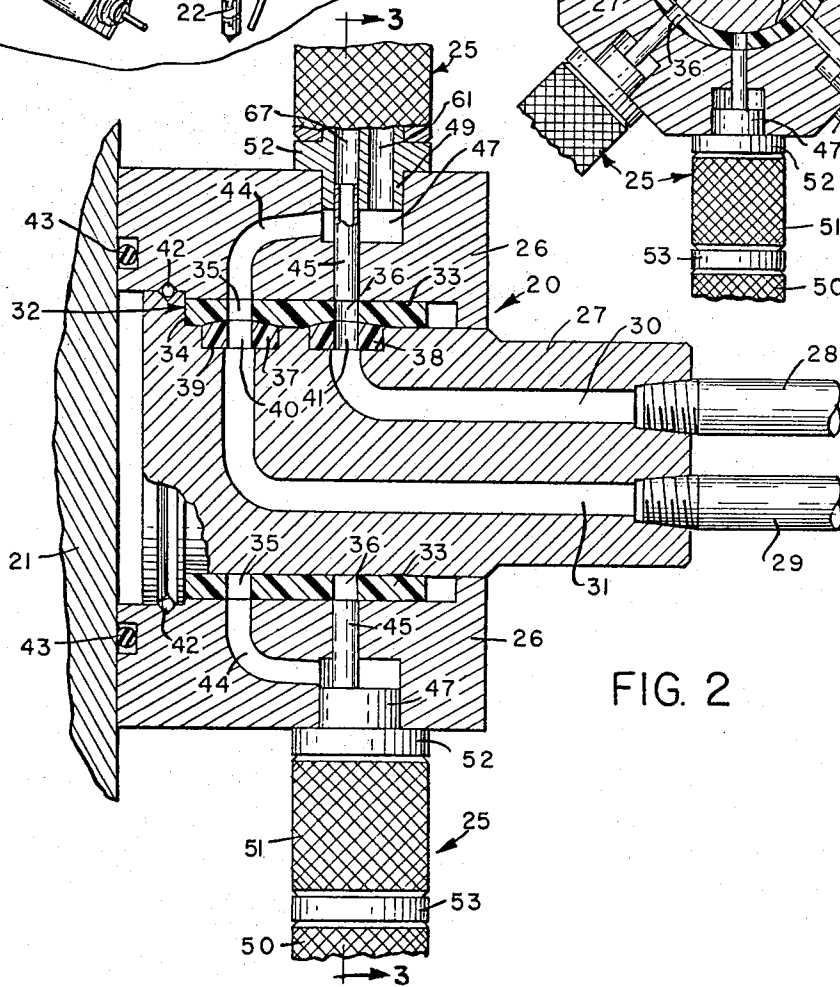
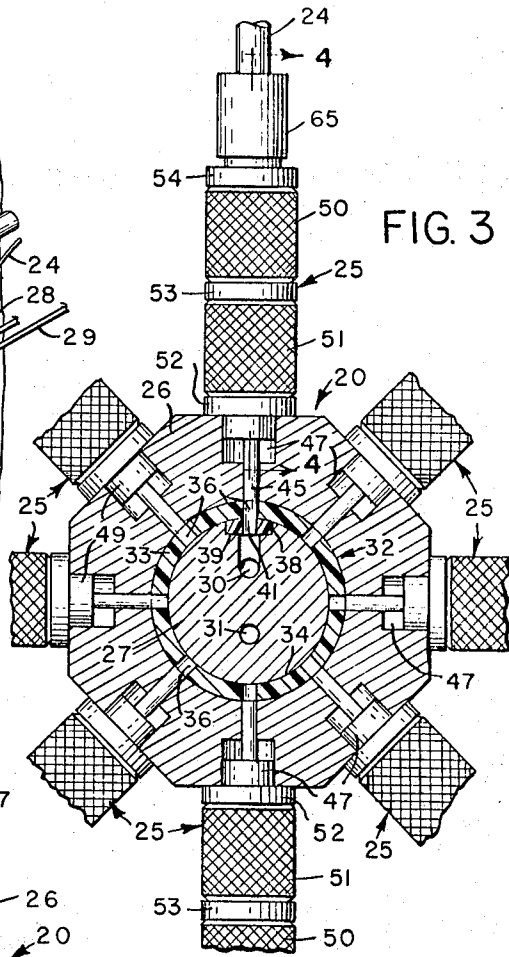

FIG. 2

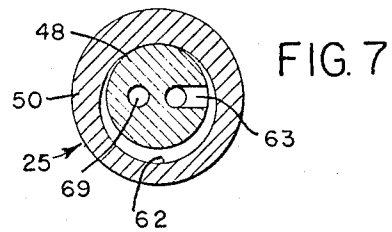
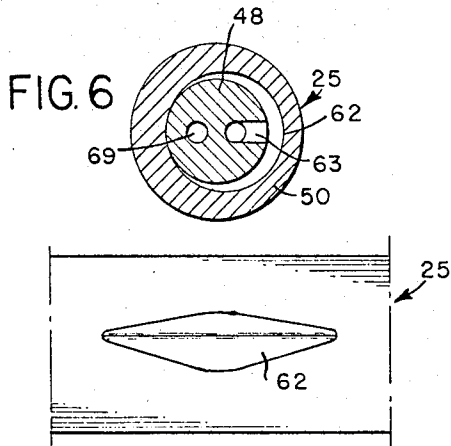
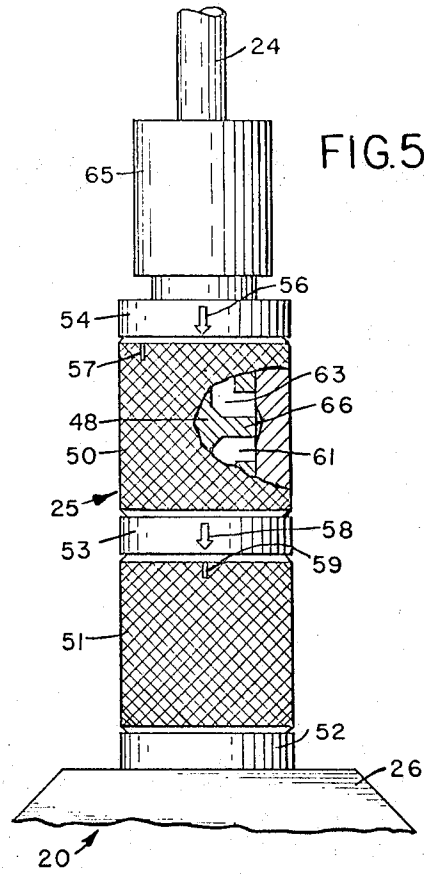
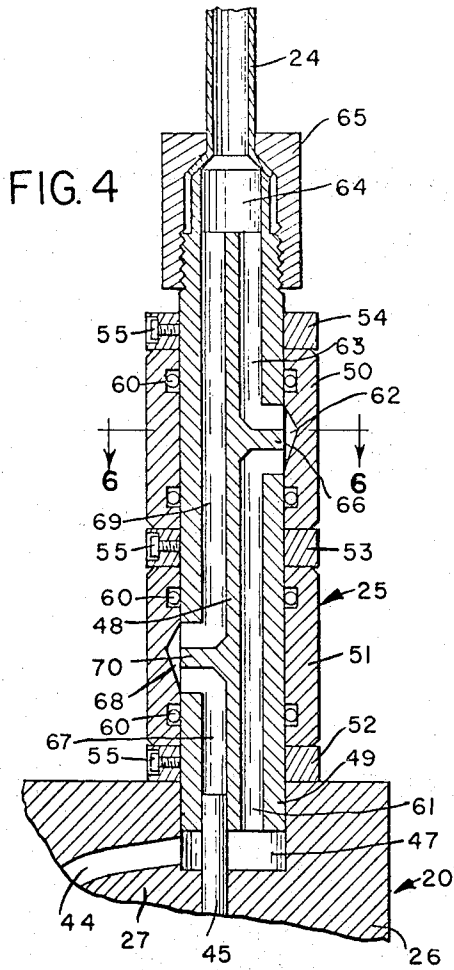
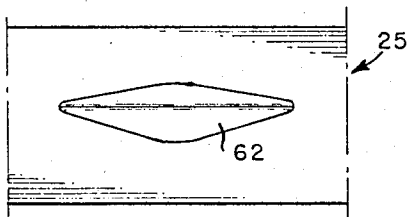

FIG. 8



CONTROL VALVE

The present invention is a divisional application of pending patent application Ser. No. 151,065 filed June 8, 1971, now U.S. Pat. No. 3,726,363, and the claims of the present invention are directed to the control valve.

An object of the present invention is to provide a coolant spider assembly that is adapted to selectively feed coolant to the spindles of turret type drilling machines in order to prolong the cutting life of tools, as well as to increase the efficiency of most multiple spindle turrets.

Another object is to provide a coolant spider assembly wherein the spider and turret are synchronized to make it possible for any or all stations on the turret to be used by various coolant fed tools, such as drills, taps, reamers, and the like.

Still another object of the present invention is to provide a coolant spider assembly that can be easily mounted on any conventional or turret drilling machine, and wherein various accessories can be used or provided, such as quick switch hose couplings, and wherein there is provided quick shut-off valves to eliminate annoying liquid splash, and the like, the present invention being adaptable to all standard turrets, and also having variable mounting configuration, as desired or required.

Still another object is to provide such a coolant spider assembly that is economical to manufacture and efficient in operation, and which is rugged in structure and efficient in use.

These and other objects of the invention will become apparent from a reading of the following specification and claims, together with the accompanying drawing, wherein like parts are referred to and indicated by like reference characters, and wherein:

FIG. 1 is a perspective view illustrating the application of the present invention.

FIG. 2 is an enlarged vertical sectional view of the fluid distributor or coolant spider assembly.

FIG. 3 is a sectional view taken on the line 3—3 of FIG. 2, and being on a reduced scale.

FIG. 4 is an enlarged sectional view taken on the line 4—4 of FIG. 3.

FIG. 5 is a side elevational view of the line of FIG. 4, and with parts broken away and in section.

FIG. 6 is a sectional view taken on the line 6—6 of FIG. 4.

FIG. 7 is a view similar to FIG. 6, but with the rotor in a different position.

FIG. 8 is a layout of the inner surface of one of the rotors.

Referring in detail to the drawings, the numeral 20 indicates the coolant spider assembly of the present invention that includes a head 21 that has a plurality of radially disposed tools 22 mounted thereon by means of adaptors or fittings 23. The numeral 24 indicates lines or conduits for conveying lubricants to the tools 22 from control valves 25. The control valves 25 are radially disposed on a body member 26.

As shown in FIG. 2, there is provided for the body member 26 a base piece 27 that has conduits 28 and 29 connected thereto whereby air and coolant can be conveyed to passageways 30 and 31 from a suitable source of supply of air and coolant.

The numeral 19 indicates a suitable mounting plate, FIG. 1.

As shown in the drawings, there is provided a seal assembly indicated generally by the numeral 32, and the seal assembly 32 includes a circular ring 33 that is mounted in a recess 34 in the base piece 27. The circular ring 33 has ports or openings 35 and 36 therein for a purpose to be later described. The numerals 37 and 38 indicate seal elements that are mounted in recesses 39 in the base piece 27, the seal elements 37 and 38 have ports or openings 40 and 41 therein respectively. The numerals 42 and 43 indicate bearings and O-rings or the like. In FIG. 2 there is provided in the body member 26 passageways or channels 44 and 45 that communicate selectively with ports 35 and 36 in the ring 33. The numeral 47 indicates a chamber or space in the body member 26.

In FIGS. 4 through 8 of the drawings, there is shown in detail the construction of the control valves 25, where it will be seen that each valve 25 includes a centrally disposed core or base piece 48, and the inner end portion 49 of the core 48 is snugly seated within the chamber 47 of the member 26. Numerals 50 and 51 indicate knurled or roughened sleeves that are rotatably mounted on the core 48, and a plurality of circular spacers 52, 53 and 54 are provided for each valve 25, as shown in the drawings. The spacers or numbers 52, 53 and 54 are held in their proper location by means of securing elements, such as set screws, bolts, or the like 55. The numerals 56 and 57 indicate coacting markings on the adjacent portions of the members 54 and 50, and similar coacting markings 58 and 59 are provided on the adjacent portions of the members 53 and 51, FIG. 5.

The numeral 60 indicates bearings or the like that are arranged internally of the sleeves 50 and 51 for assuring proper and easy rotation or adjustment of the sleeves 50 and 51 on the central core 48. The core or base piece 48 has an elongated passageway or channel 61 therein that is adapted to receive air coolant that is supplied through the passageway 44 into the chamber 47, and this material can flow through the passageway 61, and then enter a recessed area or portion 62 in the sleeve 50, and this material can then selectively flow out through a passageway 63 into a mixing chamber 64. The coupling 65 serves to detachably connect an end portion of the line or conduit 24 to the outer end of the element 48, as shown in the drawings. The numeral 66 indicates a shoulder on the member 48 which is arranged in alignment with the recessed portion 62.

The numeral 67 indicates a passageway in the member 48 that receives air from the passageway or channel 45, and this air can flow out through the passageway 67, and then through the chamber or passageway 68 in the sleeve 51, then through the passageway 69 in the member 48, and the air can then enter the mixing chamber 64 to mix with the coolant from the passageway 63 so that the intermixed air and lubricant can then flow out through the conduit 24 to one of the tools 22.

A flange or shoulder 70 on the core or member 48 is arranged adjacent the recess 68 in the sleeve 51, as shown in FIG. 4.

From the foregoing, it will be seen that there has been provided a coolant spider assembly, and in use with the parts arranged as shown in the drawings, coolant, such as air and lubricant, is adapted to be supplied from a suitable source of supply through the conduits or hoses 28 and 29, and the air and lubricant will then

enter the passageway 30 then through the port or opening 41, then through the opening 36, then through the channel or passageway 45 into the passageway 67. The air can selectively flow through the passageway 67 then through the chamber or passageway 68, then through the passageway 69 to the mixing chamber 64. Similarly, the lubricant can flow from a source of supply through the conduit or hose 29, then through the passageway 31, and the coolant or lubricating oil can then flow through the port or opening 40, then through the opening 35, then through the passageway 44 and into the chamber 47.

From the chamber 47, the coolant or oil enters the passageway 61 and then selectively flows into the passageway or recessed area 62, and then out through the passageway 63 into the mixing chamber or area 64. Thus, the lubricating oil and air can mix in the chamber 64 and be discharged out or flow out through the hose 24 to cool or lubricate one of the tools 22.

In accordance with the present invention, it will be noted that there is provided a unique combination of parts as well as a novel seal arrangement or assembly that is indicated generally by the numeral 32. The seal assembly 32 includes the ring 33 that has the ports or openings 35 and 36 therein that register with the openings 40 and 41 in the seal elements 37 and 38. This construction is such that as the body member 26 rotates on the base piece 27, the passageways 44 and 45 will move into and out of registry with the ports 35 and 36, so that the coolant and air can selectively flow through these passageways and into the control valves, as shown in the drawings.

With reference to the control valves 25, it will be noted that each has generally the same construction and each includes the non-rotary central portion or element 48 as well as the separate manually rotary sleeves 50 and 51. As shown in FIGS. 4 through 8, by rotating a sleeve such as the sleeve 50, for example, the offset recess or chamber 62 can be selectively positioned relative to the shoulder 66, so as to partially close off the flow of air through the passageways 61, 62 and 63, or else the sleeve 50 can be manually rotated to permit a lesser or greater amount of air to flow through the passageways into the mixing chamber 64. Similarly, the sleeve 51 can be manually rotated so that its offset groove or recessed chamber 68 can be arranged in blocking or closing relation with respect to the shoulder 70, or else the sleeve 51 can be positioned to permit flow of lubricant through the passageways 67, 68 and 69, or the sleeve 51 can be arranged in a position to permit partial flow of lubricant through its passageways into the mixing chamber 64.

The sleeve 50 has a mark or indicator 57 thereon for coaction with an arrow or mark 56 on the stationary element 54 and this arrangement permits a user to accurately set the parts in the desired location to accurately control the flow of air through the valves 25. Similarly, sleeve 51 and adjacent element 53 have coacting markings 59 and 58 thereon for permitting the user to accurately locate or position the sleeve 51 to accurately meter the amount of lubricant flowing through its passageways into the mixing area or chamber 64.

In the present invention there is a mixing valve and a seal assembly. The seal assembly 32 consists of elements 33, 37 and 38 that can be made of any suitable material such as plastic that have memory features. This invention includes the unique valve that functions

as a flow meter to control the flow of air and coolant. The valve 25 includes the members 50 and 51 that have the internal cam surfaces 62 and 68 that cooperate with the corresponding adjacent portions of the inner member 48, so that by rotating the members 50 and 51 the supply of air and coolant can be selectively completely closed off or permitted to flow, as desired or required.

Various tools 22 can be cooled internally by coolant from the conduits or lines 24, or if desired, the coolant can be supplied to the outside of the tools in the vicinity of the work piece, and it is to be understood that the parts are arranged and constructed so that when one of the tools 22 is in its lowermost position, the coolant will be supplied thereto and when the tool 22 is rotated out of its lowermost position, no coolant will be supplied thereto. The parts are constructed so that the coolant will only flow in the proper or desired direction, so that the coolant will not escape therefrom. The device is adapted to be used in various types of applications including deep hole drilling, and the fluid will be conveyed properly even with the parts rotating at a high speed.

There is provided an indexing arrangement that functions in the previously described manner. There is provided an in-line flow control metering valve arrangement. In regard to the seal 32, the parts can be made so that as the outer member 26 rotates, the plastic will swell to mechanically seal off the unit from associated parts. The device as adapted to be used for mist cooling of cutting tools, and there is provided a means for transferring fluid to the tools, such as the tools 22, so as to cool and lubricate the same.

With further reference to the seal 32, it will be noted that there is provided the outer ring 33 as well as the inner plugs 37 and 38 that are made of a suitable material that is somewhat flexible to form a tight seal between the adjacent parts 26 and 27 as the part 26 rotates on the member 27.

In addition, the present invention includes the control valve mechanisms 25 for the air and lubricant, so that by rotating the parts 50 and 51, a supply of air and coolant or oil can be regulated or controlled as desired.

The parts such as 21 and 26 will rotate and the member 27 is stationary.

The device may be made of any suitable material and in different shapes and sizes as desired. It will, therefore, be seen that there has been provided a system that includes coolant adaptors and inducers for new as well as existing drilling and tapping machines, and primarily, the present invention provides an improved means for delivering the coolant to the tool itself. The coolant can be fed through the tool itself to greatly reduce the heat generated by the cutting action. Various accessories can be used with the present invention, and these can be quickly fitted in place or removed to permit the same to selectively become an integral part of the apparatus so as to create a more efficient machine.

The coolant spider can be attached to any turret type machine and serves as a selector device for the spindle which is being indexed.

The fluid metering valve is provided for the coolant spider, and makes it possible to regulate the flow of liquid to the tool, and a unique feature of the valve is that the amount of required coolant can be dialed. A dual valve can be attached to the coolant spider as a metering valve for both air and liquid. Whenever shop air is available, it can be mixed with the coolant and the dual

metering valve takes over to regulate the amount of the proper mixture for each type of tool. Other accessories, such as hoses and necessary couplings with quick connects and quick disconnects may be provided as desired or required.

The present invention provides a convenient method of attaching coolant accessories to the machine, and there is provided a coordinated product or assembly, and makes it possible to meet practically every possible coolant situation, so as to simplify use thereof.

The present invention is applicable to new machines as well as permitting use with old or existing machines, and the productivity rate of each machine tool will be increased. In addition, sealing penetration will be improved or increased. Various accessories may be used such as a coolant pump, venturi, mist, pulse system, sonic atmosphere and the like. The present invention can be easily mounted on any turret type drilling machine by attaching the back plate to the turret by set screws or the like.

The parts are constructed and arranged so that quick and easy connection and disconnection from tool stations is assured, and the quick shut-off valves eliminate annoying liquid splash. The coolant spider assembly selectively feeds coolant to the spindles of turret type drilling machines so as to prolong the cutting life of tools, as well as to increase the efficiency of most multiple spindle turrets. Also the synchronization of the spider and the turret makes it possible for any or all sta-

tions on the turret to be used by various coolant fed tools such as drills, taps, reamers and the like. The device is adaptable to all standard turrets, has variable mounting configurations, and has a rugged durable construction. As shown in FIG. 1, the spider is capable of diverse use, and it can selectively flow, cool or induce the coolant internally depending upon the operation and use of the tool desired or required. The spider and flow meters may be provided as a complete unit.

10 While a preferred embodiment in accordance with the present invention has been illustrated and described, it is understood that various modifications may be resorted to without departing from the spirit and scope of the appended claims.

15 What is claimed is:

1. As a new article of manufacture, a control valve comprising an inner core member having passageways therein, a pair of sleeves rotatably mounted on said core member, first second and third collars fixedly secured to said core member, coaxing indicating means on said sleeves and collars, said sleeves having inner offset recessed cam portions defining chambers, shoulders on said inner core member for selective coaction with inner recessed cam chambers of the sleeves, and whereby by manually rotating the sleeves, the flow of material through the passageways can be regulated and controlled.

* * * * *

30

35

40

45

50

55

60

65