



US00D952912S

(12) **United States Design Patent**
Wu

(10) **Patent No.:** **US D952,912 S**

(45) **Date of Patent:** **** May 24, 2022**

(54) **VEHICLE LAMP**

(71) Applicant: **COPLUS INC.**, Tainan (TW)

(72) Inventor: **Po-Hua Wu**, Tainan (TW)

(73) Assignee: **Po-Hua Wu**, New Taipei (TW)

(**) Term: **15 Years**

(21) Appl. No.: **29/741,473**

(22) Filed: **Jul. 13, 2020**

Related U.S. Application Data

(63) Continuation-in-part of application No. 29/725,487, filed on Feb. 25, 2020, now Pat. No. Des. 919,139.

Foreign Application Priority Data

Jan. 14, 2020 (TW) 109300200
Apr. 24, 2020 (TW) 109302237

(51) **LOC (13) Cl.** **26-28**

(52) **U.S. Cl.**
USPC **D26/28**

(58) **Field of Classification Search**

USPC D26/28, 29, 30, 31, 32, 33, 34, 35, 36, D26/44
CPC F21S 48/00; F21S 48/10; F21S 48/115; F21S 48/225; F21S 48/1233; F21S 48/1266; F21S 48/1388; F21S 48/2268; F21S 41/00; F21S 41/141; F21S 41/162; F21S 41/18; F21S 41/20; F21S 41/33; F21S 41/36; F21S 41/60; F21S 43/00; F21V 21/04; F21W 2103/35; F21W 2103/40; F21W 2102/17; F21W 2102/30; F21W 2103/00; F21W 2103/55; F21W 2104/00; F21W 2107/17; F21W 2107/13

See application file for complete search history.

(56) **References Cited**

U.S. PATENT DOCUMENTS

D883,535	S	*	5/2020	He	D26/28
D890,382	S	*	7/2020	Wu	D26/28
D890,386	S	*	7/2020	Wu	D26/28
D905,301	S	*	12/2020	Wu	D26/28
D906,555	S	*	12/2020	Wu	D26/28
D912,863	S	*	3/2021	Wu	D26/28
D919,139	S	*	5/2021	Wu	D26/28
D919,141	S	*	5/2021	Wu	D26/28
D921,945	S	*	6/2021	Lin	D26/28
D925,796	S	*	7/2021	Chen	D26/28
D927,741	S	*	8/2021	Lin	D26/28
D928,999	S	*	8/2021	Wu	D26/28

* cited by examiner

Primary Examiner — Angela J Lee

(74) *Attorney, Agent, or Firm* — Lewis Roca Rothgerber Christie LLP

(57) **CLAIM**

The ornamental design for a vehicle lamp, as shown and described.

DESCRIPTION

FIG. 1 is a front perspective view of a vehicle lamp showing my new design;

FIG. 2 is a rear perspective view thereof;

FIG. 3 is a front elevational view thereof;

FIG. 4 is a rear elevational view thereof;

FIG. 5 is a left side elevational view thereof;

FIG. 6 is a right side elevational view thereof;

FIG. 7 is a top plan view thereof; and,

FIG. 8 is a bottom plan view thereof.

The broken lines in the drawings illustrate portions of the article that form no part of the claimed design.

1 Claim, 8 Drawing Sheets

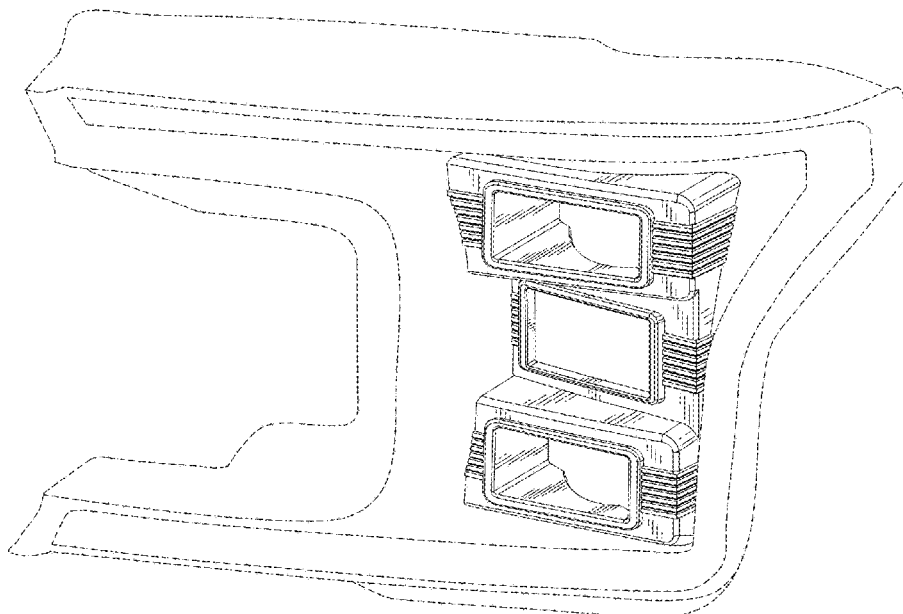

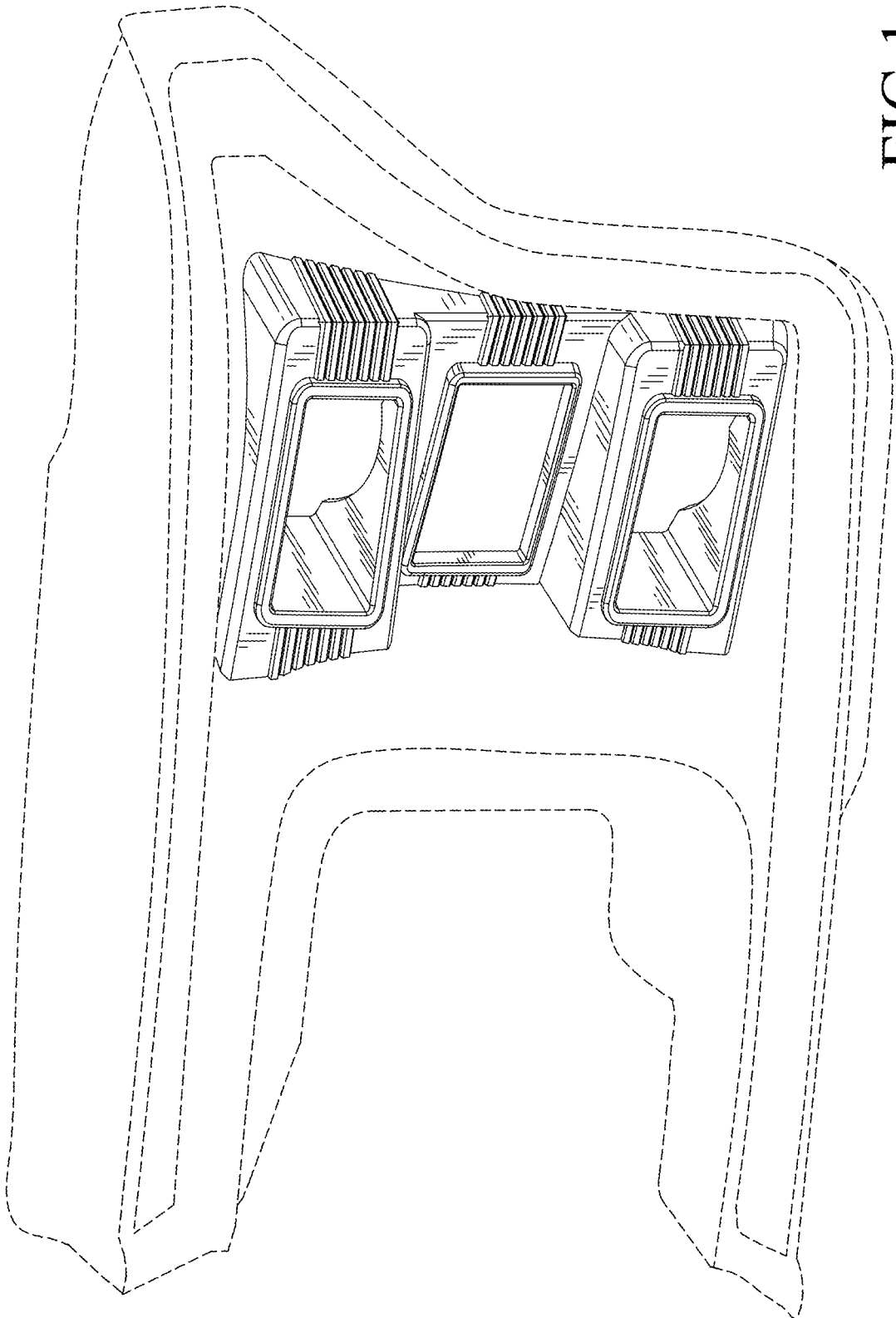

FIG. 1

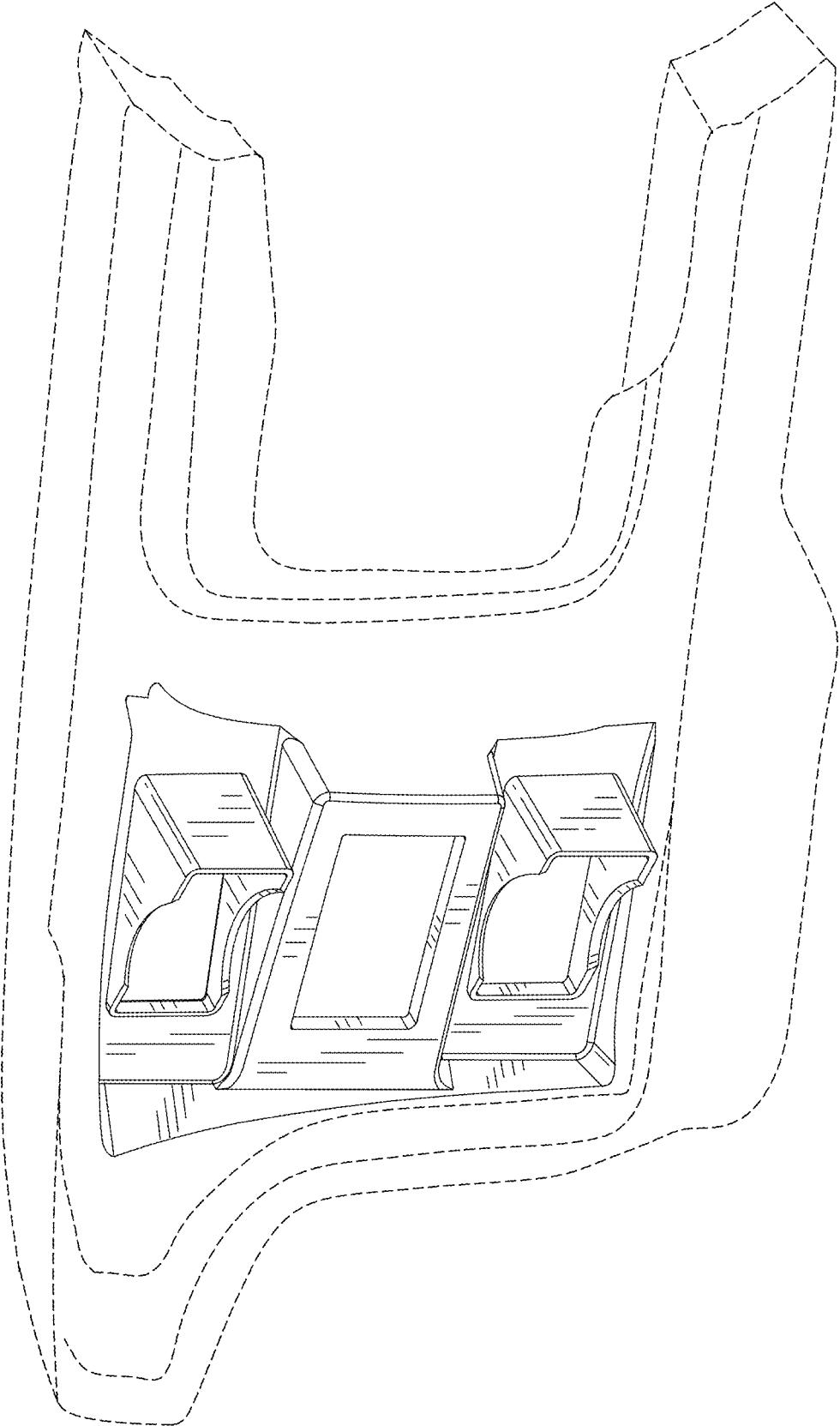

FIG.2

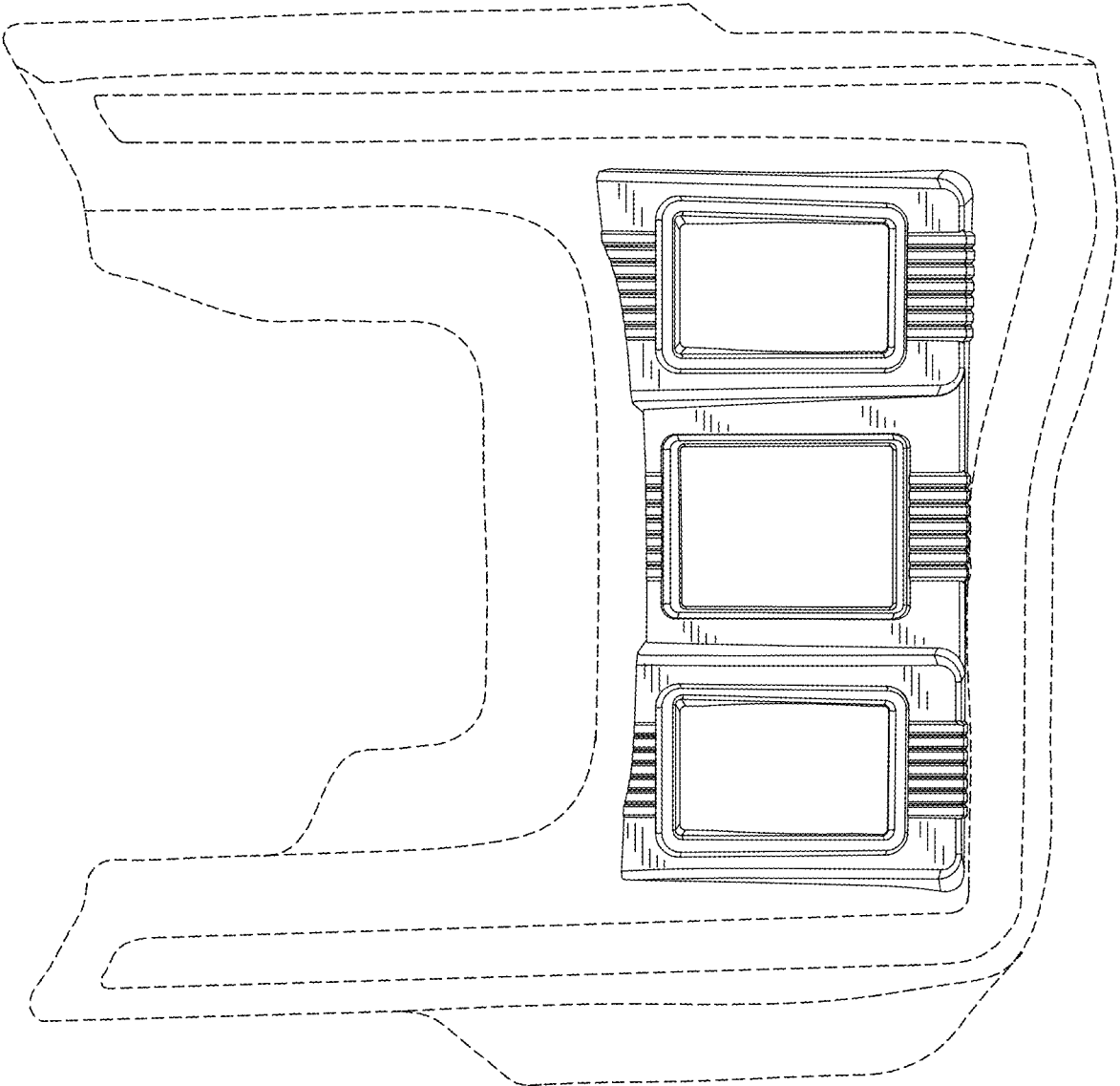

FIG.3

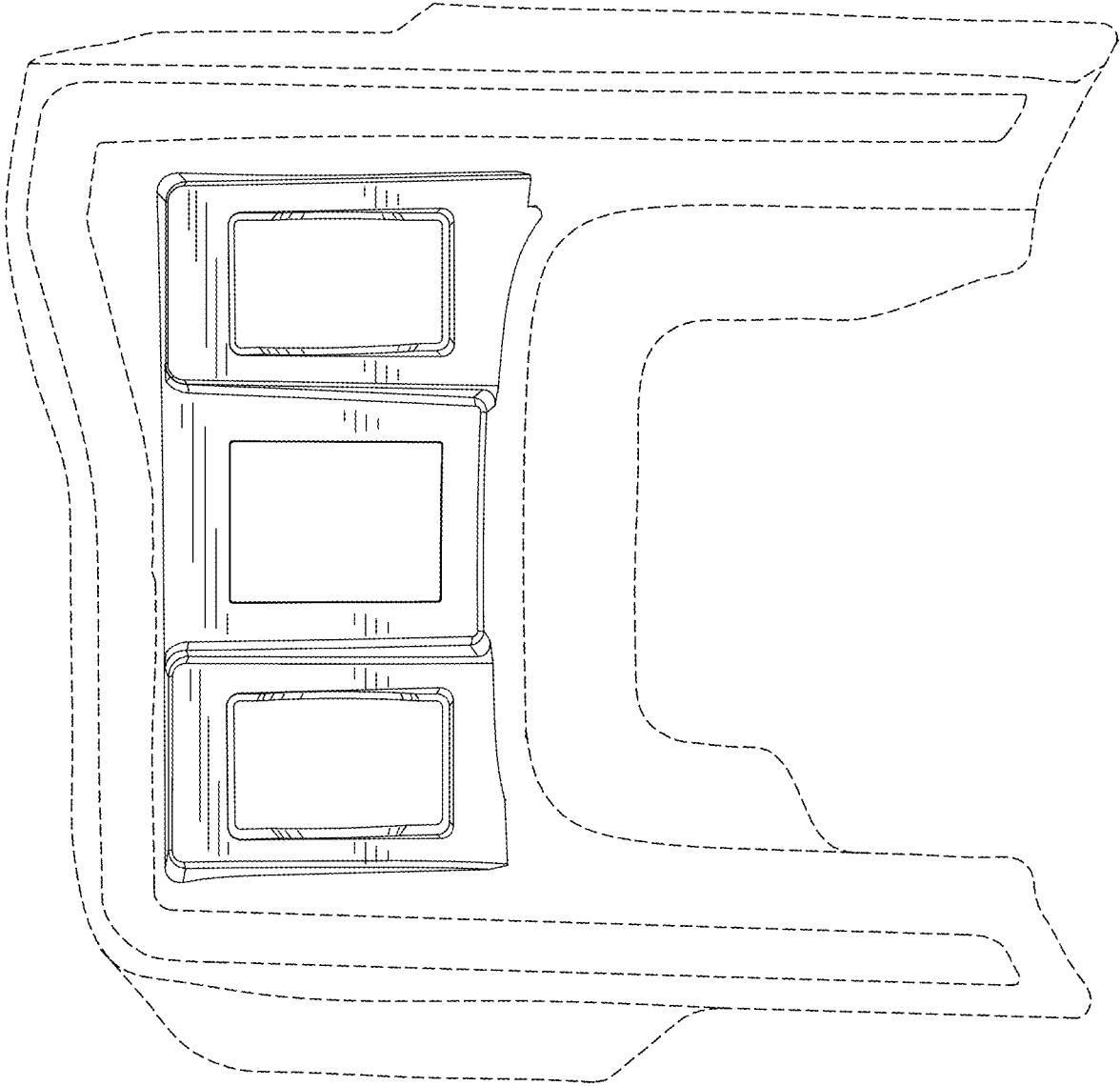

FIG.4

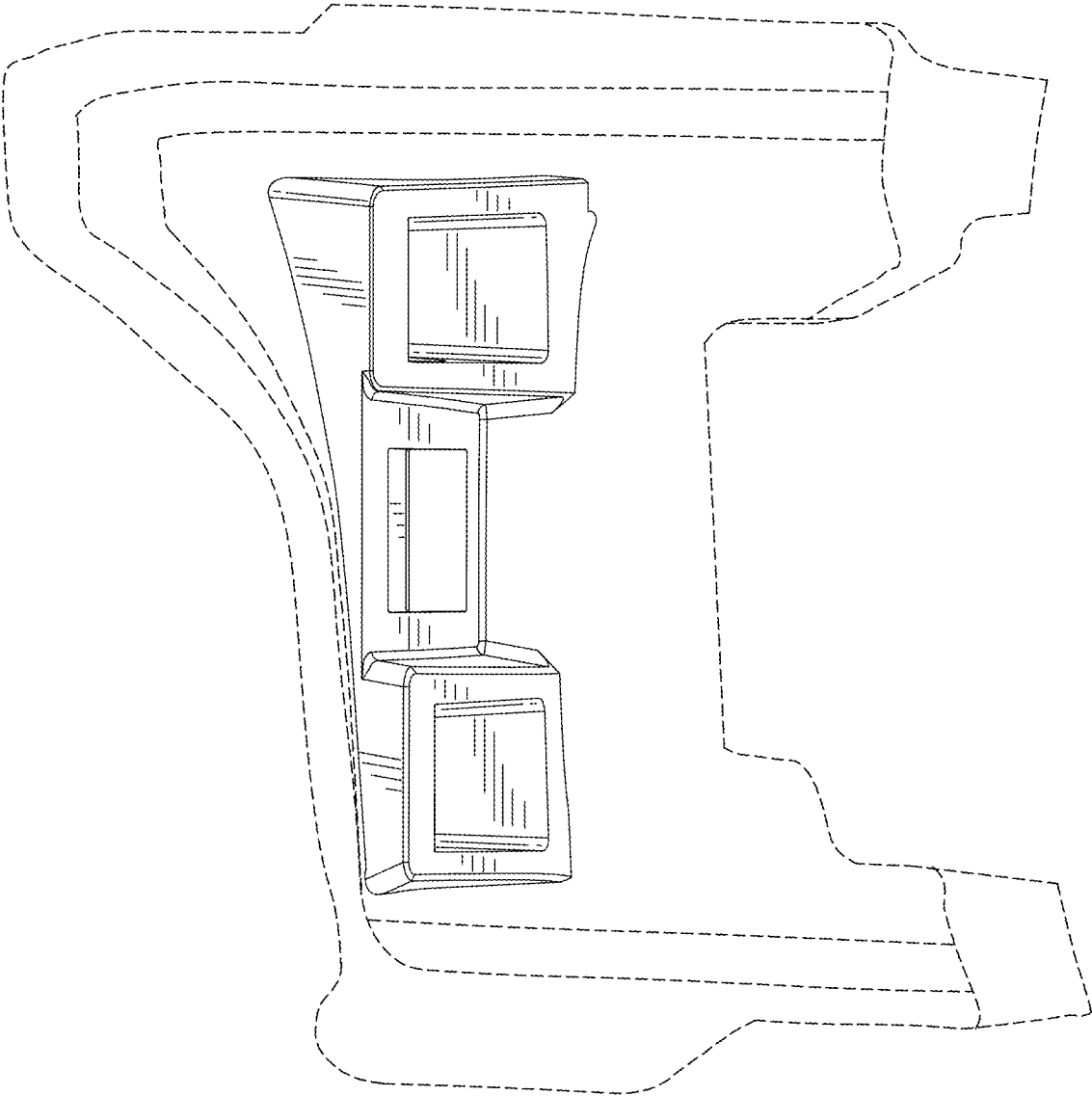

FIG.5

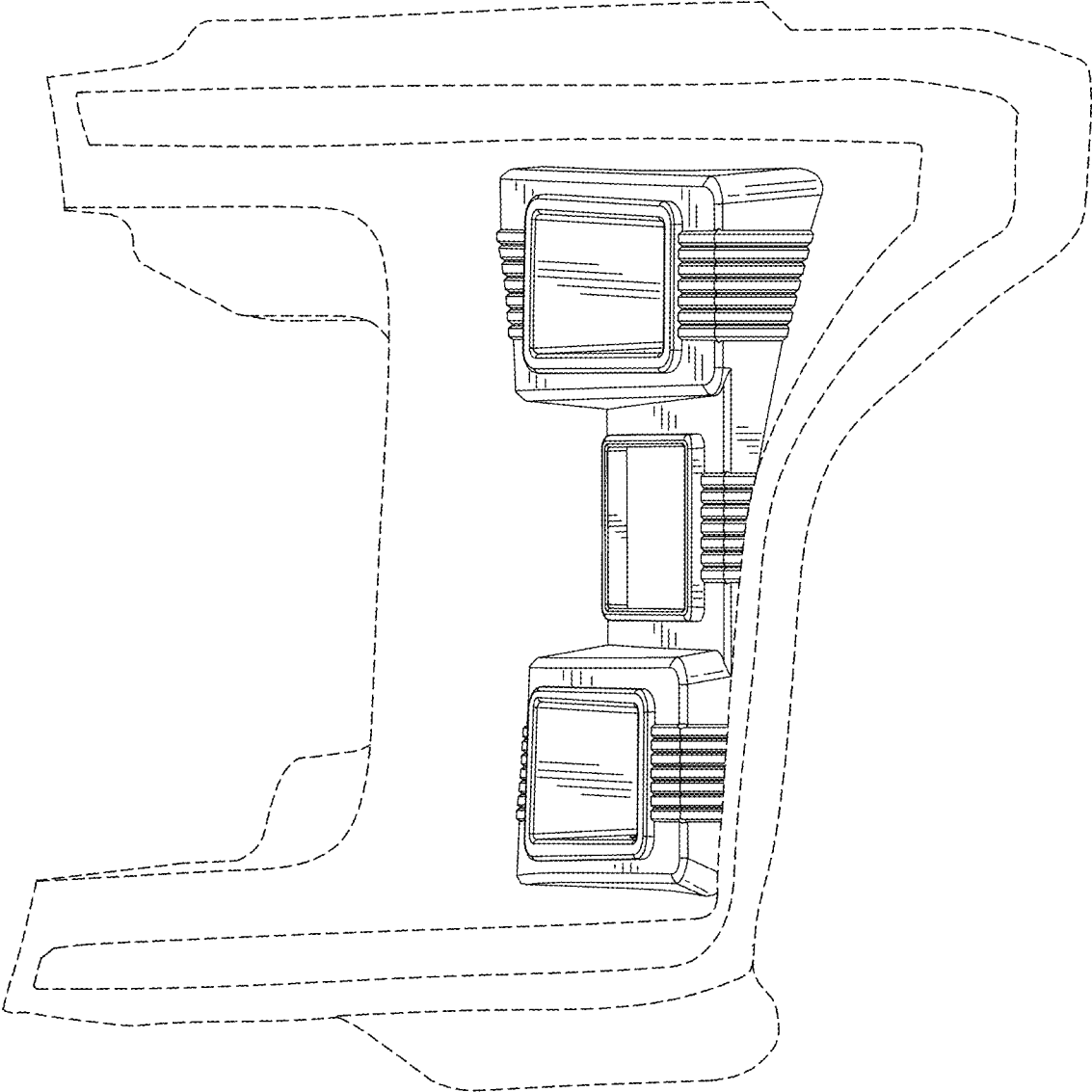

FIG.6

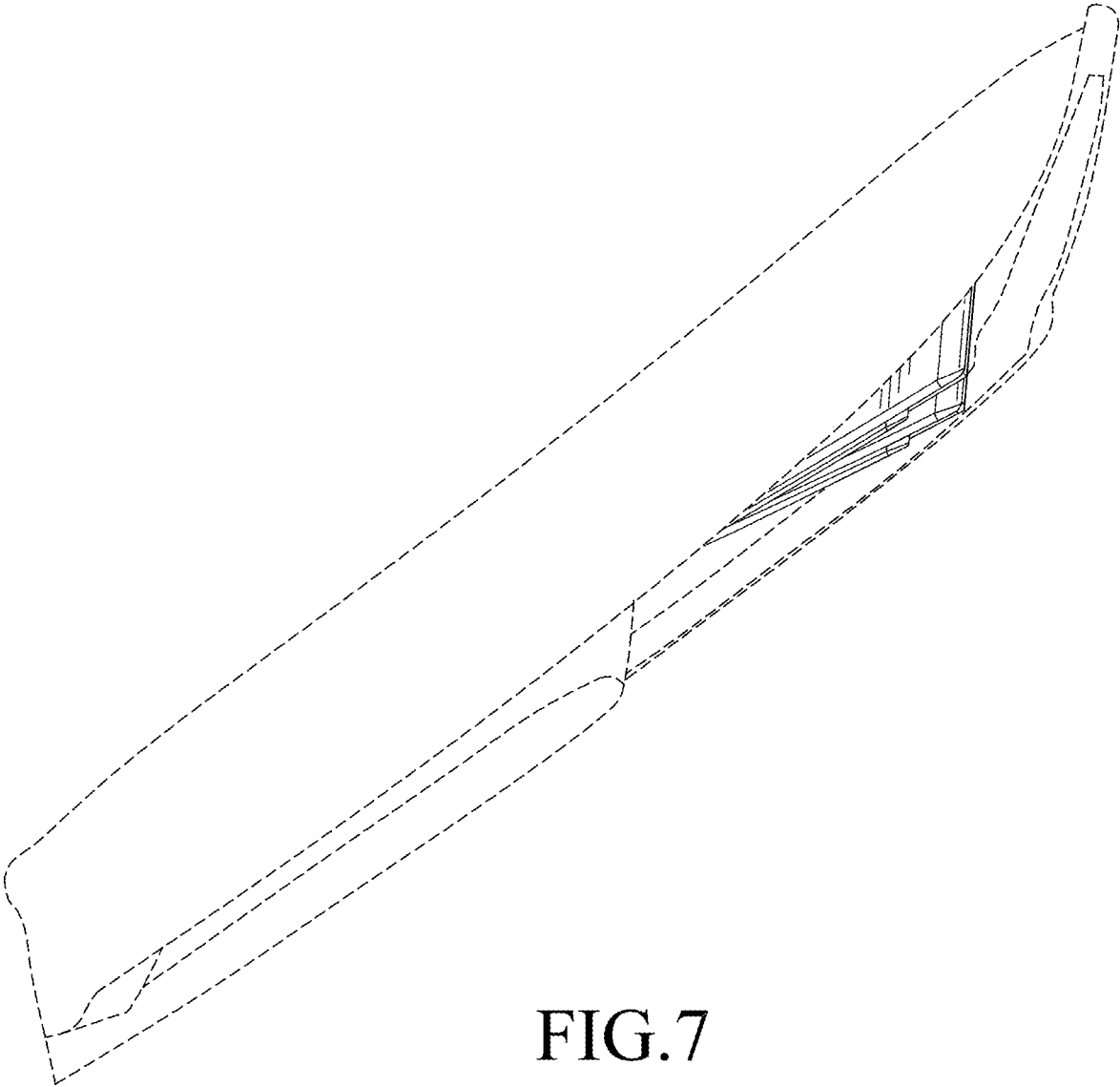

FIG. 7

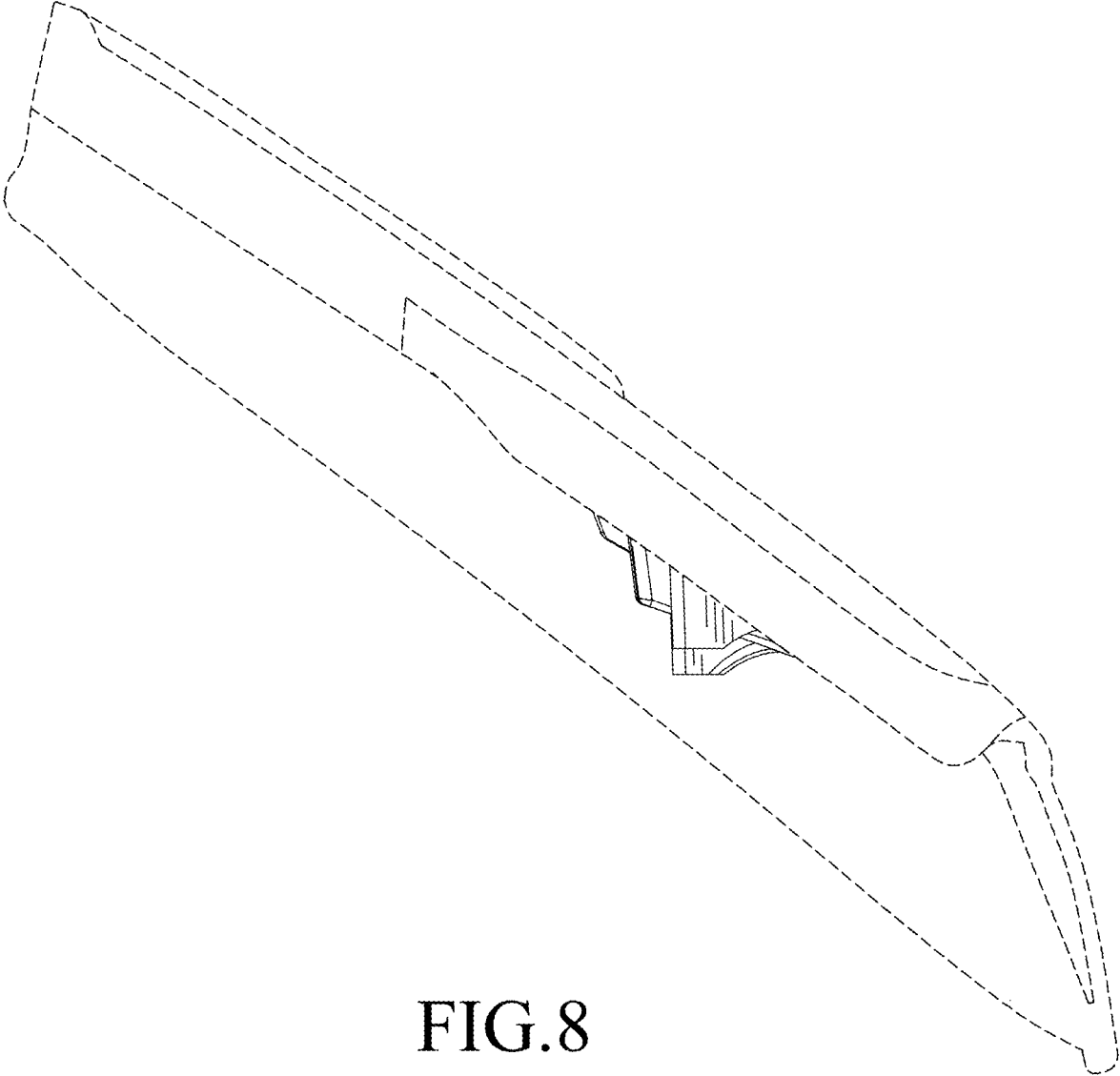

FIG. 8