

No. 613,923.

Patented Nov. 8, 1898.

H. F. HAVILAND.

TOILET PAPER CUTTING AND DELIVERING APPARATUS.

(Application filed Apr. 23, 1898.)

(No Model.)

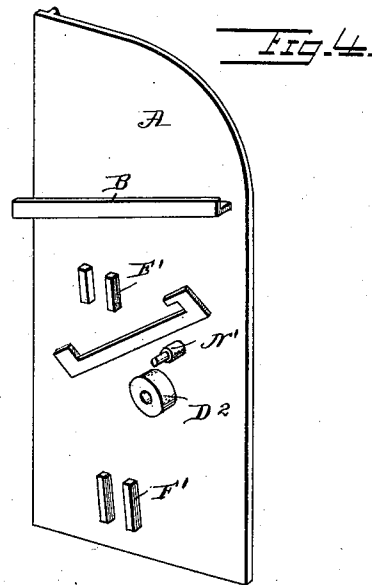
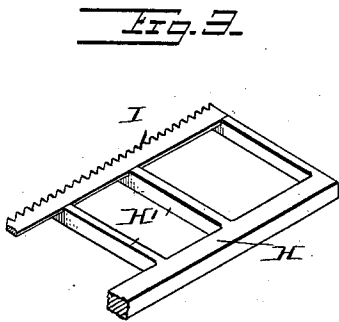
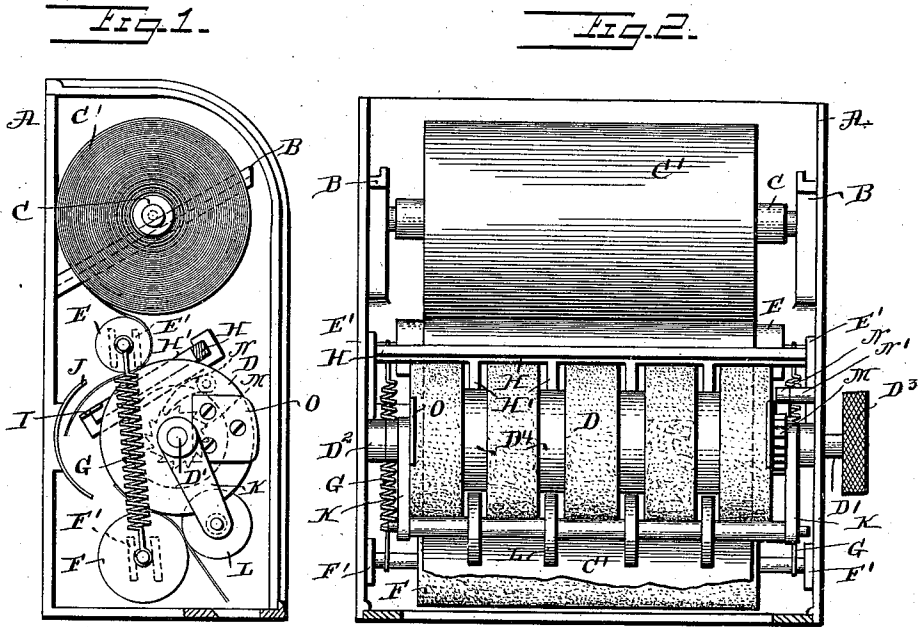

Witnesses.

Frank S. Russel
 Jesse B. Helled.

Inventor.

Harry F. Haviland

Myself and H. H. H. H.
 Attorneys

UNITED STATES PATENT OFFICE.

HARRY F. HAVILAND, OF PHILADELPHIA, PENNSYLVANIA, ASSIGNOR TO HIMSELF, HARRY D. HAVILAND, AND HENRY F. CLARK, OF SAME PLACE.

TOILET-PAPER CUTTING AND DELIVERING APPARATUS.

SPECIFICATION forming part of Letters Patent No. 613,923, dated November 8, 1898.

Application filed April 23, 1898. Serial No. 678,545. (No model.)

To all whom it may concern:

Be it known that I, HARRY F. HAVILAND, a citizen of the United States, residing at Philadelphia, county of Philadelphia, and State of Pennsylvania, have invented a new and useful Improvement in Toilet-Paper Cutting and Delivering Apparatus, of which the following is a full, clear, and exact description, reference being had to the accompanying drawings, which form a part of this specification.

My invention relates especially to toilet-paper cutters and delivery-racks; and it consists generally of a roller for holding an uncut continuous roll of paper, mechanism for unwinding and delivering the paper, and mechanism for cutting the paper by a transverse cut into sheets of substantially equal size in the process of delivery, so that the paper will be delivered to the operator in separate sheets.

It consists, further, of certain details of construction, which may be understood by reference to the following specification, in connection with the drawings forming part thereof, in which—

Figure 1 is a side view, partially in section, with the side plate removed. Fig. 2 is a front view, partially in section, with the front plate removed. Fig. 3 is a perspective view of a part of the knife. Fig. 4 is a perspective view of one of the side plates.

A is the frame or case containing the toilet-roller and the delivery and cutting mechanism.

B is a bracket projecting inwardly and upwardly from the wall of the casing, upon which rests the roller C, around which roller is wound the continuous coil or roll of paper C'. As the paper is unwound from the roller C it slides down upon the bracket B, and the roll of paper is thus caused to remain in close proximity to the friction-roller (to be hereinafter described) immediately below it. The main feed-roller D is fixed upon the revolvable shaft D', one end of which rests loosely in a bearing D² on the inside of the case, the other end of which projects through an orifice in the opposite side of the case and carries on the outside of the case a knob D³, by which the main feed-roller is operated. Above

the main feed-roller D and between it and the roller C is a friction or feed roller E, the shaft of which rests in or upon inclined ways formed in or upon the projections E' inside of and on opposite sides of the case. The roller E is free to move up and down upon its ways, but is normally held firmly against the main feed-roller by the means hereinafter described. Beneath the main feed-roller is a friction or feed roller F, the shaft of which rests in or upon ways formed in or upon the projections F' inside of and on opposite sides of the case. A tension device or spring G extends between and is secured to the shafts of rollers E and F and serves to maintain the roller F in continuous contact with the main feed-roller and normally to maintain a like contact between the main feed-roller and the roller E.

Above and in front of the main feed-roller and extending between and secured to the sides of the case is the cross-bar H. The main feed-roller is preferably provided with circumferential grooves D⁴ of sufficient depth to accommodate rearward extensions H' from the cross-bar H. Similar extensions H' are secured to the sides of the case, and to the rear ends of said extensions is secured a toothed knife or cutter I. This cutter, as shown, is located parallel with and immediately behind the main feed-roller. Secured to the rear wall of the case is the curved guide J for directing the forward end of the paper-roll between the main feed-roller and roller F.

K K are links pivoted on the shaft of the main feed-roller, on either side of the same, and carry at their free ends a shaft sustaining the guide-rollers L, which extend within the circumferential grooves in the main feed-roller and rest loosely upon the roller F. The purpose of said rollers is to prevent any tendency of the paper to follow around the main roller D and also to assist in ejecting it from the case. Upon the main-feed-roller shaft is a ratchet M, and coacting therewith is a pawl N, pivoted on the end of a rod N', extending inwardly from the side of the case. On either end of the main feed-roller is a cam O, which projects beyond the circumference of the main feed-roller and engages the roller E in each complete rotation of the main feed-roller and

lifts the roller E out of frictional contact with the main feed-roller.

The operation of the apparatus just described is as follows: The operator turns the main feed-roller from left to right or, as shown in the cross-section, from right to left, the engagement of the pawl N with the ratchet M serving to prevent the rotation of the sheet in the opposite direction. This causes the paper to feed between the main feed-roller and roller E. Further rotation of the main feed-roller feeds the paper over the cutter I, while the guide J directs the paper between the main guide-roller and roller F. The paper is then fed forward by the frictional contact between the main feed-roller and the rollers E and F, respectively, until the main feed-roller is brought into such a position that the cam O is brought into contact with and raises the roller E out of frictional contact with the main feed-roller. The feeding of the paper is now confined to that produced by the frictional contact between the main feed-roller and roller F, and the paper is drawn taut over the cutter I and severed. As the main feed-roller continues to turn the cam passes from under the roller E, the spring G draws the roller E again into frictional contact with the main feed-roller, the feeding of the paper between the last-mentioned rollers is recommenced, and the severed sheet is delivered from the machine.

It will be observed that the upper roller E feeds the paper from the roll at the top, while the lower feed-roller F delivers the paper from the machine, and that the purpose of intermittently stopping the coaction between roller E and the main feed-roller is to enable a tension to be applied to the paper by confining the feeding action to that produced by the frictional contact of the main feed-roller with roller F, thus drawing the paper tightly over the sharp teeth of the cutter, cutting off a sheet of convenient size for use.

My invention is not limited to the details of construction enumerated in the foregoing description, as my invention is capable of embodiment in forms without detailed resemblance to the one shown and described herein. In the particular organization I have described the roller C should be of some heavy metal or material, so that the roll at all times will rest firmly against the case in order that some resistance may be opposed to the feeding mechanism, a resistance sufficient to prevent the constant-feed mechanism from feeding the paper from the roll during the stoppage of the intermittent-feed mechanism.

What I claim is—

1. In a paper cutting and delivering apparatus, a main feed-roller, a feed-roller continuously coacting therewith, a feed-roller intermittently coacting therewith, and a cutter over which the paper is adapted to pass, and by which it is adapted to be cut while the last-mentioned roller is not coacting with the main feed-roller.

2. In a paper cutting and delivering apparatus, a main feed-roller, a feed-roller continuously coacting therewith, a feed-roller intermittently coacting therewith, and a cutter over which the paper is adapted to pass, and by which it is adapted to be cut while the last-mentioned roller is not coacting with the main feed-roller, and means to cause the last-mentioned roller to intermittently coact with the main feed-roller.

3. In a paper cutting and delivering apparatus, a main feed-roller, two secondary feed-rollers, means to rotate the main feed-roller, means to cause one of the secondary rollers to coact intermittently with the main feed-roller, and a cutter over which the paper is adapted to pass, and by which it is adapted to be cut while the last-mentioned secondary roller is not coacting with the main feed-roller.

4. In a paper cutting and delivering apparatus, a main feed-roller, two secondary feed-rollers, one of which continuously coacts with the main feed-roller, means to rotate the main feed-roller, means to cause one of the secondary rollers to coact intermittently with the main feed-roller, and a cutter over which the paper is adapted to pass, and by which it is adapted to be cut while the last-mentioned secondary roller is not coacting with the main feed-roller.

5. In a paper cutting and delivering apparatus, a main feed-roller, two secondary feed-rollers, one of which continuously coacts with the main feed-roller, means to rotate the main feed-roller, means connected with the main feed-roller to cause one of the secondary feed-rollers to coact intermittently with the main feed-roller, and a cutter over which the paper is adapted to pass, and by which it is adapted to be cut while the last-mentioned secondary roller is not coacting with the main feed-roller.

6. In a paper cutting and delivering apparatus, a main feed-roller, two secondary feed-rollers, means to rotate the main feed-roller, means to cause one of the secondary rollers to coact intermittently with the main feed-roller, a cutter over which the paper is adapted to pass, and by which it is adapted to be cut while the last-mentioned secondary roller is not coacting with the main feed-roller, and means to normally hold both feed-rollers in coaction with the main feed-roller.

7. In a paper cutting and delivering apparatus, a main feed-roller, two secondary feed-rollers, one of which continuously coacts with the main feed-roller, means to rotate the main feed-roller, means connected with the main feed-roller to cause one of the secondary feed-rollers to coact intermittently with the main feed-roller, a cutter over which the paper is adapted to pass, and by which it is adapted to be cut while the last-mentioned secondary roller is not coacting with the main feed-roller, and means to normally hold both feed-rollers in coaction with the main feed-roller.

8. In a paper cutting and delivering apparatus, a device for carrying a roll of paper, a

plurality of feed-rollers normally coacting at two points to feed the paper from the roll, means for intermittently stopping the coaction at one of said points, and a cutter over which the paper is adapted to pass, and by which it is adapted to be cut during the said stoppage of coaction between the feed-rollers.

9. In a paper cutting and delivering apparatus, a main feed-roller, two secondary feed-rollers, a tension device to normally hold both secondary feed-rollers in coaction with the main feed-roller, a cam carried by the main feed-roller in line of movement with one of said secondary rollers and adapted at one period in the rotation of the main feed-roller to raise the last-mentioned secondary roller out of frictional contact with the main feed-roller, and a cutter over which the paper is adapted to pass, and by which it is adapted to be cut while the last-mentioned secondary roller is out of frictional contact with the main feed-roller.

10. In a paper cutting and delivering apparatus, a main feed-roller having circumferential grooves, two secondary feed-rollers, a tension device to normally hold both feed-rollers in coaction with the main feed-roller, means to rotate the main feed-roller, a cam carried by the main feed-roller in line of movement with one of said secondary rollers and adapted at one period in the rotation of the main feed-roller to raise the last-mentioned secondary roller out of frictional contact with the main feed-roller, a cross-bar, rearward extensions therefrom extending through the grooves of the main feed-roller, a cutter secured to said rearward extensions over which the paper is adapted to pass, and by which it is adapted to be cut while the last-mentioned secondary roller is out of frictional contact with the main feed-roller.

11. In a paper cutting and delivering apparatus, a main feed-roller having circumferential grooves, two secondary feed-rollers, a tension device to normally hold both feed-rollers in coaction with the main feed-roller, means to rotate the main feed-roller, a cam carried by the main feed-roller in line of movement with one of the secondary rollers and adapted at one period in the rotation of the main feed-roller to raise the last-mentioned secondary roller out of frictional contact with the main feed-roller, a cross-bar, rearward extensions therefrom extending through the grooves of the main feed-roller, a cutter secured to said rearward extensions over which the paper is adapted to pass, and by which it is adapted to be cut while the last-mentioned secondary roller is out of frictional contact with the main feed-roller, links depending from the shaft of the main feed-roller, a shaft sustained by the free ends of said links, the said shaft carrying guide-rollers extending within the grooves of the main roller and resting upon one of said secondary feed-rollers.

12. In a paper cutting and delivering appa-

ratus, a main feed-roller having circumferential grooves, two secondary feed-rollers, a tension device to normally hold both feed-rollers in coaction with the main feed-roller, means to rotate the main feed-roller, a cam carried by the main feed-roller in line of movement with one of said secondary rollers and adapted at one period in the rotation of the main feed-roller to raise the last-mentioned secondary roller out of frictional contact with the main feed-roller, a cross-bar, rearward extensions therefrom extending through the grooves of the main feed-roller, a cutter secured to said rearward extensions over which the paper is adapted to pass, and by which it is adapted to be cut while the last-mentioned secondary roller is out of frictional contact with the main feed-roller, and a guide-roller below the main feed-roller and resting upon one of said secondary feed-rollers.

13. In a paper cutting and delivering apparatus, a main feed-roller, two secondary feed-rollers, a tension device to normally hold both secondary feed-rollers in coaction with the main feed-roller, a cam carried by the main feed-roller in line of movement with one of said secondary rollers and adapted at one period in the rotation of the main feed-roller to raise the last-mentioned secondary roller out of frictional contact with the main feed-roller, a cutter over which the paper is adapted to pass, and by which it is adapted to be cut while the last-mentioned secondary roller is out of frictional contact with the main feed-roller, and a guide-roller below the main feed-roller and resting upon one of said secondary feed-rollers.

14. In a paper cutting and delivering apparatus, a device for carrying a roll of paper, a main feed-roller, a feed-roller intermittently coacting therewith for feeding the paper from the roll, a feed-roller continuously coacting therewith for delivering the paper from the machine, and a cutter located between the continuously-coacting feed-roller and the intermittently-coacting feed-roller over which the paper is adapted to pass, and by which it is adapted to be cut while the last-mentioned feed-roller is not coacting with the main feed-roller.

15. In a paper cutting and delivering apparatus, the combination of a device for carrying a roll of paper, mechanism for intermittently feeding the paper from the roll, a cutter for severing the paper into sheets, and mechanism for drawing the paper over the cutter during the intermittent stoppage of the first-named mechanism.

16. In a paper cutting and delivering apparatus, the combination of a device for carrying the roll of paper, mechanism for intermittently feeding the paper from the roll, a cutter for severing the paper into sheets, and mechanism for drawing the paper over the cutter during the intermittent stoppage of the first-named mechanism and for delivering the severed sheet.

17. In a paper cutting and delivering apparatus, the combination of a device for carrying a roll of paper, a cutter for severing the paper into sheets, mechanism between the roll and the cutter for intermittently feeding the paper from the roll, and mechanism for drawing the paper over the cutter to cut the same during the intermittent stoppage of the first-named mechanism.
18. In a paper cutting and delivering apparatus, the combination of a device for carrying a roll of paper, a cutter for severing the paper into sheets, mechanism between the roll and the cutter for intermittently feeding the paper from the roll, and mechanism for drawing the paper over the cutter to cut the same during the intermittent stoppage of the first-named mechanism and for delivering the severed sheet.

Signed by me, at Philadelphia, this 21st day of April, 1898.

HARRY F. HAVILAND.

Witnesses:

FRANK S. BUSSER,
HORACE M. GOODWIN.