

(19) World Intellectual Property Organization
International Bureau



(43) International Publication Date
25 October 2001 (25.10.2001)

PCT

(10) International Publication Number
WO 01/79862 A1

- (51) International Patent Classification⁷: **G01P 9/04** **William, III**; 29931 Imperial Drive, San Juan Capistrano, CA 92675 (US). **DAO, Phu, Cu**; 6717 Cloverly Avenue, Arcadia, CA 91007 (US).
- (21) International Application Number: PCT/US01/08604
- (22) International Filing Date: 19 March 2001 (19.03.2001) (74) Agent: **ANDRAS, Joseph, C.**; 19900 MacArthur Boulevard, Suite 1150, Irvine, CA 92612 (US).
- (25) Filing Language: English (81) Designated State (national): JP.
- (26) Publication Language: English (84) Designated States (regional): European patent (AT, BE, CH, CY, DE, DK, ES, FI, FR, GB, GR, IE, IT, LU, MC, NL, PT, SE, TR).
- (30) Priority Data:
09/550,355 14 April 2000 (14.04.2000) US
- (71) Applicant: **MICROSENSORS, INC.** [US/US]; 3001 Redhill Avenue, Building 3, Suite 104, Costa Mesa, CA 92626 (US). **Published:**
— with international search report
- (72) Inventors: **HSU, Ying, Wen**; 6455 Frampton Circle, Huntington Beach, CA 92648 (US). **REEDS, John**,
For two-letter codes and other abbreviations, refer to the "Guidance Notes on Codes and Abbreviations" appearing at the beginning of each regular issue of the PCT Gazette.

(54) Title: Z-AXIS MICRO-GYRO

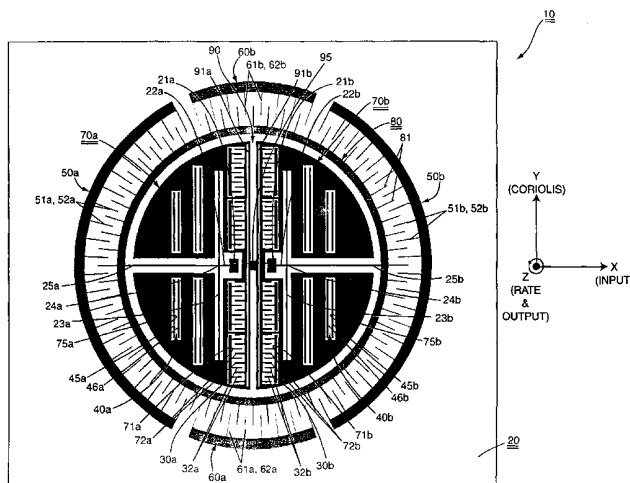

(57) Abstract: A miniature gyroscope (micro-gyro) (10) used for detection of angular velocity. The micro-gyro (10) disclosed is a "Z-axis gyro" that measures the rate of angular rotation about a rate axis perpendicular (Z-axis) to the plane of the device. Z-axis gyros can be mounted flat on a horizontal surface, and measure the rotational rate of an object turning about a vertical axis. The micro-gyro uses multiple elements configured in a single-layer planar structure. The elements include two input elements (70a, 70b) and an output element (80). The two input elements (70a, 70b) are driven into oscillation in opposite directions to provide a balanced momentum. In response to a rotational rate, the input elements (70a, 70b) create Coriolis forces which are detected and amplified by the output element (80). The input elements (70a, 70b) are separate from the output element (80) to eliminate the coupling problem associated with prior single mass structures. The multi-element design enables active suppression of imbalance, and permits the optimization of inertial gain that enhances micro-gyro performance.

WO 01/79862 A1

Z-AXIS MICRO-GYRO

Background of the Invention

Field of the Invention

5 This invention relates generally to rate-of-rotation sensors that use the gyroscopic principle, i.e. devices that measure the Coriolis force created by the conservation of momentum of a moving body. The invention more particularly relates to a class of such devices called "micro-gyros," which are small, inexpensive, and able to withstand rough environments for long periods of time.

10

Description of the Related Art

Micro-gyros generally rely on limited oscillatory motion, or vibration, whereas traditional "spinning wheel" gyroscopes rely on the conservation of momentum in a structure that is subject to full rotational motion. The input and output vibrations of a micro-gyro may be linear or non-linear (e.g. arcuate) depending on the design. In the field of micro-gyros, therefore, the terms used to describe the directions of motions and the interrelated forces can be confusing. Applicants will refer to three separate axes in describing and claiming the present invention:

15

- (1) the rate axis;
- (2) the input axis; and
- (3) the output axis.

20

The rate axis is the easiest to understand because it is the axis about which rotation is measured (e.g. deg./sec). Conversely stated, a micro-gyro is used to measure the angular velocity or rotational rate about the micro-gyro's *rate axis*. If the micro-gyro's rate axis lies in its structural plane, it is sensitive to pitch or roll and it may be regarded as an "X-" or "Y-axis" micro-gyro. If the micro-gyro's rate axis is perpendicular to its structural plane, it is sensitive to yaw and it may be regarded as a "Z-axis" micro-gyro.

25

The input and output axes are used with reference to an input element and, subject to any intervening mechanism that may translate one type of motion to another, may also be meaningful with respect to an output element. The input and output axes are orthogonal to one another and to the rate axis. The input and output elements vibrate in "directions" that may be linear or non-linear depending on the design of the micro-gyro. The input and output directions, however, are always

30

orthogonally related to one another no matter how simple or complex their respective motions are. The input and output elements and their corresponding directions may be directionally described relative to the input and output axes as follows:

5 (a) an *input element* is constantly driven to vibrate at a predetermined rate inside the gyro along an input path that may be along (linear) or about (e.g. rotational) the *input axis* depending on the design, the *input element* being variably subjected to Coriolis force that is created in an *output direction* that is perpendicular to the input direction and in proportion to the micro-gyro's rate of rotation about the rate axis, the *output direction* being along (linear) or about (rotational) the *output axis* depending on the design;

10 (b) an *output element* is caused to vibrate when the *input element* is subjected to Coriolis force by virtue of the *input element* being coupled to the *output element*. (note that the movement of the output element may or may not be the same as the *output direction*)

15 Earlier micro-gyros use a single element for both input and output. In Draper Patent No. 5,016,072, for example, a single mass is supported by a system of flexible linkages that permit movement in two axes. A system of electrodes drive the mass to vibrate in one axis and sense the motion of the mass due to Coriolis force in the other axis. Other Draper patents disclose micro-gyros that use different types of input and output motion that also rely on a single mass. The direct coupling of input and output motion through a single mass severely limits the sensitivity of the micro-gyro because the input motion is generally many magnitudes larger than the output motion and requires complex control schemes to compensate for undesirable motion.

25 Neukemans et al Patent No. 5,488,862 discloses a micro-gyro with two elements, but the design does not allow for independent movement of each element. The outer frame is rigidly connected to the inner frame such that the two frames essentially behave as a single mass element. When the inner frame rotates, the outer frame rotates with it.

30 Lutz Patent No. 5,804,312 discloses two elements that are not rigidly connected, but are carried one on top of the other. In particular, it uses "an oscillatory mass" moving in a linear vibrating direction, and a "deflectable mass" caused by Coriolis force to move in a linear vibrating direction that is perpendicular to the motion of the oscillatory mass. Lutz is a Z-axis gyro in that the Coriolis effect is

used to determine angular velocity of the entire sensor about a rate axis that is perpendicular to the linear vibrating directions of both masses. The deflectable mass, however, is mounted on top of the oscillatory mass in a "piggy-back" fashion. The Lutz design, therefore, does not provide for independent movement of the input and output elements in that the deflectable mass must move with the oscillatory mass on which it is mounted.

Applicants' commonly assigned patent application nos. 08/870,812 and 08/943,305 disclose micro-gyro designs that address many of the shortcomings in the known prior art. In particular, each of the disclosed designs have separate input and output elements where the input element is designed to resonate in a primary mode at a first frequency and in a secondary mode at a second frequency. The output element is designed to resonate in a third mode at the first frequency. The input and output elements are dynamically connected by flexures that efficiently couple the elements in the first frequency but inefficiently couple them in the second frequency. In the unique micro-gyros disclosed in application nos. 08/870,812 and 08/943,305, therefore, the input element's Coriolis-induced vibrations are effectively coupled to the output element while the output element's resulting motion is effectively decoupled from and does not return to and interfere with the input element. This unique, dynamic coupling/decoupling of input and output elements allows for increased sensitivity and enables the electronic correction of system imbalances due to manufacturing tolerances.

The preferred embodiment of common assignee application 08/870,812 (now issued as U.S. Patent 5,955,668) is an X-axis micro-gyro because its rate axis lies in the device plane. It has a planar "disk-in-a-ring" arrangement formed from an outer ring and an inner disk. The input element is the ring. It is driven in a input direction, about an input axis that extends through its center, perpendicular to the device plane. The output element is the disk and it is caused, in the presence of a rotational rate and resulting Coriolis force that is transferred from ring to disk, to vibrate or "tip and tilt" in an output direction about an output axis that is in the device plane, perpendicular to the rate axis. The micro-gyro of application 08/870,812 "separates the mass (momentum of inertia) of the constant motion element driven to oscillate around the input axis from the mass (momentum of inertia) of the variable motion sensing element which creates the measured force." It accomplished that result by "using: (a) an outer ring-shaped element which oscillates around the input

axis, and (b) an inner disk-shaped element which oscillates, or rocks, around the output axis as a result of the Coriolis effect.” Its dual-element structure “permits the ring and the disk to be excited independently, so that each can be dynamically compensated for manufacturing tolerances by counterbalancing.”

5 The preferred embodiment of common assignee application No. 08/943,305 carried forward the theme of independent input and output elements, but it is a Z-axis micro-gyro because its rate axis is perpendicular to the device plane. It has a planar “plate-in-a-frame” arrangement formed from a rectangular frame and a rectangular plate located inside the frame. The input element is the frame and it is
10 driven along an input axis that lies in the device plane. The output element is the plate and it is caused, in the presence of a rotational rate and resulting Coriolis force that is transferred from frame to plate, to vibrate in an output direction, along an output axis that also lies in the device plane.

 The micro-gyros of application nos. 08/870,812 and 08/943,305 offer
15 significant advancements over the prior art by virtue of providing independent input and output elements in a single layer structure. In particular, the designs allow for high signal sensitivity and for dynamic compensation of manufacturing deviations. Due to the use only one input element and one output element, however, the micro-gyros of application nos. 08/870,812 and 08/943,305 provide unbalanced
20 momentum and are somewhat subject to signal saturation in the presence of linear or translational acceleration.

 There remains a need, therefore, for a micro-gyro that provides separation between input and output elements within a single layer structure while providing a balanced momentum and the ability to reject false inputs from
25 translational acceleration.

Summary Of Invention

 In a first aspect, the invention may be regarded as a method of detecting rotational rate about a rate axis by vibrating an input element and vibrating
30 an output element about an axis that is parallel to the rate axis in response to the Coriolis force generated by the input element.

 In a second aspect, the invention may be regarded as a method detecting rotational rate about a rate axis by: vibrating an input element relative to an input axis at a first frequency; causing the input element to vibrate in response to

Coriolis force relative to an output axis at a natural resonance centered on a second frequency that is substantially different from the first frequency such that coriolis-induced vibrations at the first frequency are inefficiently dissipated in the first element; causing an output element to vibrate in response to Coriolis force relative to an output axis at a natural resonance centered on a third frequency that is substantially the same as the first frequency such that coriolis-induced vibrations at the first frequency are efficiently transferred to and dissipated in the output element.

In a third aspect, the invention may be regarded as a device for detecting rotational rate about a rate axis, comprising: an input element that vibrates; an output element that vibrates about an output axis that is parallel with the rate axis; and linkage connecting the input element and the output element to transfer Coriolis force from the input element to the output element.

In a fourth aspect, the invention may be regarded as a device for detecting rotational rate about a rate axis, comprising: an input element that vibrates along an input axis; an output element that vibrates about an output axis that is perpendicular to the input axis; and linkage connecting the input element to output element to transfer Coriolis force from the input element to the output element.

In a fifth aspect, the invention may be regarded as a device for detecting rotational rate about rate axis, comprising: an input element that vibrates along an input axis; an output element that receives Coriolis force from the input element; and linkage connecting the input element to output element, said linkage redirecting the direction of the Coriolis force such that the output element vibrates about an output axis that is parallel with the rate axis.

In a sixth aspect, the invention may be regarded as A device for detecting rotational rate about a rate axis, comprising: A substrate that is perpendicular to the rate axis; an input element that vibrates in a plane that is parallel to the substrate; an output element that vibrates in response to Coriolis force from the input element; and linkage connecting the input element to the output element such that the output element vibrates about an axis that is parallel to the rate axis and in a plane that is parallel to the substrate.

In a seventh aspect, the invention may be regarded as a micro-gyro for detecting rotational movement about a rate axis, comprising: first and second input elements that vibrate in opposition to one another in an input direction to generate perpendicular Coriolis force in response to rotational movement about the rate axis,

the first and second input elements vibrating in opposition to one another at or near a resonant frequency in the input direction; an output element that receives Coriolis force from the first and second input elements to cause the output element to vibrate in an output direction, the output element vibrating under Coriolis force at or near its resonant frequency in the output direction, which frequency is substantially similar to the resonant frequency of the first and second input elements in the input direction in order to enhance transfer of Coriolis force from the first and second input elements to the output element; and first and second flexures connecting the first and second input elements to the output element to transfer Coriolis force, the flexures dynamically coupling the first and second input elements to the output element at one frequency for transferring the Coriolis force, and the flexures dynamically decoupling the first and second input elements from the output element at other frequencies so that vibrating motion of the first and second input elements in the input direction does not cause substantial motion of the output element in the input direction.

15

BRIEF DESCRIPTION OF DRAWINGS

Figure 1a is a top plan view of a three-element Z-axis micro-gyro 10 according to a first preferred embodiment of this invention;

5 Figure 1b is an exploded perspective view of the first preferred micro-gyro 10 of Figure 1a;

Figure 2 is a close-up view of a drive feedback electrode 40a used in the first preferred micro-gyro 10 of Figure 1a;

Figure 3 is a cross-section of the drive feedback electrode 40a of Figure 2, taken along sections lines 3-3;

10 Figure 4 is a close-up view of an output sensing electrode 50a used in the first preferred micro-gyro 10 of Figure 1a;

Figure 5 is a functional block diagram of first preferred micro-gyro of Figure 1a connected to suitable control and sense electronics;

15 Figure 6 is a top plan view of a three-element Z-axis micro-gyro 110 according to a second preferred embodiment of this invention;

DETAIL DESCRIPTION OF THE PREFERRED EMBODIMENTS

Figure 1a is a top plan of a three-element Z-axis (TEZA) micro-gyro 10 according to a first-preferred embodiment of this invention. This embodiment has 20 three main components: (1) a substrate 20, (2) a plurality of elements supported above the substrate 20, and (3) a plurality of stationary electrodes located on the substrate 20 for driving, sensing, and adjusting the motion of the vibrating structures. Figure 1b, for the sake of clarity, is an exploded view that shows the vibrating elements floating above the substrate 20 and the various electrodes described below.

25 The substrate 20 provides a solid foundation for the vibrating elements and for the stationary electrodes that interact with those elements. The micro-gyro 10 has three vibrating elements: two input elements 70a, 70b (first and second); and one output element 80. In this particular embodiment, the input elements 70a, 70b are semicircular and the output element 80 is ring-shaped. The semicircular input 30 elements 70a, 70b are arranged back to back to form a full circle and the ring-shaped output element 80 surrounds them both.

The substrate 20 in this embodiment has two anchors 21a, 21b that rise above its upper surface. The input elements 70a, 70b and the output element 80 are supported above the substrate 20 by flexures, starting with two flexure stubs 22a,

22b that are connected to corresponding ones of the two anchors 21a, 21b. In other words, the two input elements 70a, 70b and the one output element 80 share the two flexure stubs 22a, 22b. The flexure stubs 22a, 22b are combined with other flexures to support the input and output elements as follows.

5 The input elements 70a, 70b are supported by a “T-shaped” combination of the two flexure stubs 22a, 22b and two input flexures 23a, 23b that are arranged cross-wise to those flexure stubs at flexure joints 24a, 24b. The spaced-apart tips of the input flexures 23a, 23b connect to interior locations of the
10 semicircular input elements 70a, 70b and easily flex relative to the flexure joints 24a, 24b in order to constrain the input elements 70a, 70b to vibration along the input axis (x-axis). If the input elements 70a, 70b are vibrating along the input axis and micro-gyro 10 is rotated about the Z-axis, then the input elements 70a, 70b are subjected to Coriolis force along the output axis. Note that the input flexures 23a, 23b are very rigid along their length and that the flexure stubs 22a, 22b serve as “moment arms” or
15 “lever arms” that permit rotational movement of the flexure joints 24a, 24b relative to the anchors 21a, 21b. Any motions of the input elements 70a, 70b along the output axis, due to Coriolis force being exerted from rotation of the overall micro-gyro 10 about the rate axis, are applied to the flexure joints 24a, 24b through the input flexures 23a, 23b as a torque about anchors 21a, 21b.

20 The output element 80, provided here as a ring, is supported above the substrate 20 by an “I-shaped” combination of the two flexure stubs 22a, 22b and two output flexures 25a, 25b that, starting at the flexure joints 24a, 24b, continue radially outward from flexure stubs 22a, 22b to the output element 80. The two anchors 21a, 21b are relatively close together as compared with the length of the output flexures
25 25a, 25b such that the output element 80 is essentially free to “rotationally” vibrate around the vertical axis of the micro-gyro 10. As such, if the vibrating input elements 70a, 70b are subjected to Coriolis force, their output motions are applied to the flexure joints 24a, 24b at the end of a moment arm that reacts around the anchors 21a, 21b, whereby the linear Coriolis forces applied in the output or Y-direction are
30 translated into rotational vibrations of the ring-shaped output element 80 (i.e. linear output motion along the output or Y-axis is translated into rotational motion about the rate or Z-axis)

 The micro-gyro 10 includes means for driving the input elements 70a, 70b, the preferred driving means being a plurality of drive actuation electrodes 30a,

30b that are electrically isolated from the substrate 20 and under the control of external drive circuitry.

The preferred micro-gyro 10 further includes driven motion sensing means for capacitive sensing of the driven motion of the input elements 70a, 70b, the preferred driven motion sensing means being a plurality of drive feedback electrodes 40a, 40b. Other structure that could be suitably used as the driven motion sensing means includes interdigitated fingers or other means of sensing such as resistive, optical, acoustic, electron tunneling, field effect, and others.

In operation, the input elements 70a, 70b are excited to oscillate back and forth along the input axis (X-axis). The input flexures 23a, 23b accommodate this motion by bending slightly and provide a mechanical spring force that returns the input elements 70a, 70b to their initial positions. The first and second input elements 70a, 70b are driven to move in opposite directions. This opposed motion provides a means to electrically cancel out the effect of external acceleration, i.e. to prevent such acceleration from affecting the micro-gyro's output.

The input elements 70a, 70b are driven in opposition to one another. In the preferred embodiment, in fact, the input elements 70a, 70b are electrically driven in opposite directions and mechanically designed to favor vibration in opposition to one another. In particular, the preferred input elements 70a, 70b are connected together by a mechanical linkage 90 that floats above the substrate and is designed such that the input elements 70a, 70b and the mechanical linkage 90 that connects them together causes the input elements 70a, 70b to naturally oscillate in opposite phase at a unique resonance. The preferred linkage 90 includes a pair of linking flexures 91a, 91b that are connected to either side of the input elements 70a, 70b such that the linking flexures 91a, 91b may "bow" outward from the input elements 70a, 70b, and a floating junction 95 that connects the two linking flexures 91a, 91b at their respective midpoints.

When the substrate 20 is stationary (no rotation about the rate axis), only the input elements 70a, 70b will vibrate and the ring-shaped output element 80 will remain stationary. When the substrate is rotated about the rate axis (Z-axis) at a rotational rate Ω (e.g. deg./sec), the movements of the input elements 70a, 70b in the input direction along the input or X-axis will create Coriolis forces that cause the input elements 70a, 70b to also vibrate in the output direction along the output or Y-axis. The magnitude of the Coriolis force is directly proportional to the magnitude of the

rotational rate Ω . Since the input elements 70a, 70b vibrate in opposite directions, the Coriolis-induced vibrations occurring in the output direction are also opposite of each other. For example, if the Coriolis-induced movement of the first input element 70a is in the +Y direction then the Coriolis-induced movement of second input
5 element 70b is in the -Y direction, and vice versa.

The Coriolis forces generated by the input elements 70a, 70b are transferred into the output element 80 in a unique manner. In particular, one end of each "I-shaped" combination formed from one of the flexure stubs 22a, 22b and a corresponding one of the output flexures 25a, 25b is connected to one of the anchors
10 21a, 21b, and the other end is connected to the ring-shaped output element 80. The input flexures 23a, 23b are connected to the "I-shaped" combination between these two endpoints, at the flexure joints 24a, 24b. Under the influence of a rotational rate Ω , the Coriolis forces imposed on the input elements 70a, 70b are directed in the +/- Y-directions, respectively. Due to the connection geometry of the various flexures,
15 the Coriolis forces are converted from opposed linear forces into rotational forces or torques that cooperatively rotate the ring-shaped output element 80 in one direction of the other, that rotation being detected by sensing electrodes 50a, 50b. To enhance the transfer of Coriolis force, the ring-shaped output element 80 is designed to have a natural resonance oscillating in rotation that is near the natural resonance
20 of the input elements 70a, 70b oscillating in the input direction (X-direction). By detecting the motion of the output element 80, it is possible to measure a Coriolis force that is proportional to the rotational rate Ω .

Methods of Activation and Feedback Sensing:

The input elements 70a, 70b can be driven into oscillation in a number of ways by well established techniques known to those skilled in the art of micro-gyro systems. The available means for driving the input elements 70a, 70b include electrostatic, magnetic, and piezo-electric systems. Figure 1 illustrates the presently preferred way -- the use of electrostatic forces. The following description is directed
30 to the first drive element 70a. In the case, the first input element 70a includes a plurality (four) of apertures 71a that have inwardly extending comb-fingers 72a. The substrate 20 supports a corresponding plurality (four) of stationary drive actuation electrodes 30a that have comb-fingers 32a that extend in the opposite direction such

that the drive electrodes' comb-fingers 32a are interdigitated with the input element's comb-fingers 72a

In operation, a voltage is applied to the stationary drive actuation electrodes 30a to produce a differential voltage between the drive actuation electrodes' comb-fingers 32a and the input element's comb-fingers 72a. The voltage difference creates two opposing electric charges on the surface between the comb-fingers 32a, 72a such that an attractive force is generated. By alternating the potential on the drive actuation electrodes 32a, the first input element 70a can be driven into oscillation along the direction formed by longitudinal axes of the comb-fingers 32a, 72a, i.e. back and forth along the input axis (X-axis). The same driving action is also exerted on the second input element 70b with identically-constructed apertures 71b and comb-fingers 72b that interact with drive actuation electrodes 30b and comb-fingers 32b.

The input elements 70a, 70b should be driven in opposite phase in order to balance the momentum. This can be accomplished by electronically controlling the movement of the input elements 70a, 70b, by mechanically controlling the movement of the input elements 70a, 70b with a mechanical linkage 90, or both. The purpose of the mechanical linkage 90 is to design into the structure a specific resonance mode at which the input elements 70a, 70b will naturally oscillate in opposite phase, the specific resonance of opposed oscillation being uniquely different from the mode in which the input elements 70a, 70b would oscillate in-phase with each other (together). The linkage 90 also compensates for some tolerance variation, ensuring that a relatively matched "peak" resonance will be excited. A presently preferred structure for achieving this is by providing the input elements with linking flexures 91a, 91b along their facing sides, and by connecting the two linking flexures 91a, 91b with a floating junction 95.

The input elements 70a, 70b can be driven into oscillation using either open or closed-loop control. Under open loop control, the motion of the input elements 70a, 70b is controlled only by the drive voltage applied to the stationary drive actuation electrodes 30a, 30b. This method of activation requires less circuitry, but also permits uncontrolled changes in the drive amplitude due to external or environmental influences. Example of such influences includes temperature, pressure, and aging. As the open loop drive motion could become highly sensitive to

environmental influences, closed-loop control is preferred because it would generally eliminate the effect of external environmental influences.

Closed loop control requires feedback on the motion of the input elements 70a, 70b. There are several possible means for sensing the movement of the input elements 70a, 70b. Available means include measuring changes in capacitance, piezo-electric, magnetic, and optical effects. In the preferred embodiment, the micro-gyro 10 uses capacitance as the sensing medium for feedback purposes. In the micro-gyro 10 of Figures 1a and 1b, the capacitive feedback is provided with stationary drive feedback electrodes 40a, 40b that include first and second rails 45a, 46a and 45b, 46b. The stationary drive feedback electrodes 40a, 40b detect changes in capacitance as the input elements 70a, 70b oscillate.

Figure 2, viewed in conjunction with Figures 1a and 1b, illustrates the structure of the drive feedback electrodes 40a, 40b in more detail. Here we focus on one of the drive feedback electrodes 40a that senses the movement of the first input element 70a. The input element 70a includes a window 75a. The window 75a surrounds the first and second rails 45a, 46a to form a pair of parallel capacitors in conjunction with the nearby sides of the window 75a: as the distance changes between the sides of the input element's window 75a and the rails 45a, 46a, the two capacitance values also change. These capacitance changes can be measured by using electrical circuits known to those skilled in the art of micro-gyro systems. The two capacitors formed by the two rails 45a, 46a operate in opposite sense, that is when one capacitor increases, the other decreases. The provision of drive feedback electrodes 40a (40b) with rails 45a, 46a, (45b, 46b) that form capacitors that operate in opposition provides a way for differential sensing, which results in improved sensitivity. In differential mode, as compared to an absolute mode, the effects of environment and electrical noise are drastically reduced because these effects are canceled out. All effects that affect both capacitors are eliminated from the sensing circuit.

Figure 3 is a cross sectional view of Figure 2 taken along section lines 3-3, showing the rails 45a, 46a of the drive feedback electrode 40a extending upward from the substrate 20 and into the aperture 75a of the input element 70a. As further shown in Figures 2 and 3, the first and second rails 45a, 46a are connected to first and second traces 47a, 48a that provide an electrical path for connection to

capacitance processing circuitry. The rails 45a, 46a must be electrically isolated from the substrate 20 in order to enable the capacitance sensing. This isolation is accomplished by using a passivation layer 22.

5 **Method of Rate Sensing:**

 The Coriolis force generated by the micro-gyro 10 can be detected by measuring the oscillatory motion of the output element 80. The detection of the ring-shaped element's motion can be accomplished in two different modes: open-loop, and closed-loop. In the open-loop mode, the output element 80 is free to rotate in an oscillatory manner whenever a Coriolis force is generated. The amplitude of the output element's oscillatory movement is the measure of the rotational rate Ω . In the closed-loop mode, feedback is used in conjunction with an actuation system to actively keep the output element 80 in a known null-position. In the closed-loop mode, therefore, the electrical voltage (or current) necessary to counteract the

10 Coriolis force is the measure of the rotational rate. The sensitivity of the micro gyro is not changed with closed-loop measurement, but the maximum rate detectable is greatly increased, and the time of detection is significantly reduced. In Figures 1a and 1b, a pair of output sensing electrodes 50a, 50b are used for sensing the rate of rotation and a pair of output balancing electrodes 60a, 60b are for rebalancing the

15 output element 80 (i.e. for continually repositioning it to the "null-position" under closed-loop control). In operation, an electrical potential is applied to the output balancing electrodes 60a, 60b and to the output element 80. The voltage necessary to keep the output element 80 in the null-position is controlled based on the feedback from the output sensing electrodes 50a, 50b.

25 Figure 4 is a close-up view of an output sensing electrode 50a, and the output element 80. As shown, numerous comb-fingers 81 are extending outwardly from the ring-shaped output element 80 and two sets of comb-fingers 51a, 52a are extending inwardly from the output sensing electrodes 50a. This same structure is used for the other output sensing electrode 50b and for both output balancing

30 electrodes 60a, 60b and is used, therefore, for both sensing and balancing.

 The comb-fingers 51a and 52a are positioned between adjacent pairs of comb-fingers 81, 81 extending from the ring-shaped output element 80. For sensing purpose, the comb-fingers 51a, 52a will detect a change in capacitance as the output element 80 rotationally oscillates within its limited range of motion. The

differential change in capacitance between the comb-fingers 51a, 52a provides a measurement of motion that is independent of temperature. A pair of traces 53a, 54a are used to bus the comb-fingers 51a, 52a to an external connection point. For balancing, different voltages are applied to the comb-fingers 61a, 62a (see Figures 1a and 1b) to provide a net force that imports motion to ring-shaped output element 80.

Method of Self-Test and Correction:

The output sensing electrodes 50a, 50b and the output balancing electrodes 60a, 60b provide a unique means for self-testing the micro gyro 10. To do so, the output balancing electrodes 60a, 60b are intentionally injected with a voltage that moves the ring-shaped output element 80. The resulting movement can be verified with the output sensing electrodes 50a, 50b. The measured change in the capacitance value can be compared to acceptable values that were obtained during calibration and stored in memory. In this manner, the micro-gyro 10 can be tested at the start of every application. The self-testing capability is particularly crucial for applications where high reliability and safety is involved.

The micro-gyro 10 also incorporates a feature for correcting imbalance that occurs due to structural deviations within normal manufacturing tolerances. For example, a net torque may be imported to the output element 80 in the absence of a rate because the input elements 70a, 70b fail to oscillate in exact opposition to each other due to manufacturing and/or electronic deviations. The small torque generated by this manufacturing tolerance will be transferred to the output element 80 as a false Coriolis force. The signal induced by the imbalance is often much larger than the Coriolis force to be measured. The error can be uniquely removed with the output balancing electrodes 60a, 60b, however, using synchronous demodulation or other signal processing techniques known to those skilled in the art. In the preferred embodiment, the control circuitry actively corrects such error signal by correcting the motion of the input elements 70a, 70b using electrostatic forces. In Figures 1a and 1b, the output balancing electrodes 60a, 60b can be used to impart a translational or rotational force, as desired, to the output element 80 to correct for the mismatched forces. To do so, the output balancing electrodes 60a, 60b need to be designed as shown in Figure 4 with offset electrodes.

Drive and Control Electronics

Figure 5 illustrates a block diagram for controlling and conditioning the micro-gyro 10. The Drive & Control block 92 contains the circuitry to apply varying potentials to the drive actuation electrodes 30a, 30b. For closed-loop control, the Drive & Control block 92 receives input from drive feedback electrodes 40a, 40b. The Sense Amplifier block 93 receives a signal from the output sensing electrodes 50a, 50b, and then amplifies, filters, and buffers the signal. The resulting analog signal is then converted into digital format through A/D Converter block 94. The Force Rebalance block 96 receives the position information about the rotation of the output element 80, and depending on the control signal, provides a counterbalancing by driving the output balancing electrodes 60a, 60b with voltages that rebalance the output element 80, i.e. that return it to a null-position. Finally, the Dynamic Compensation block 97 contains the circuitry to correct for imbalances due to normal manufacturing deviation. The correction values are taken from the Memory/Calibration block 91, the values having been stored there during an initial sensor calibration at the time of manufacture. In addition to manufacturing tolerances, variations due to other parameters such as temperature, acceleration, or pressure can also be included. The design of these electronics circuits is well known to those skilled in the art of micro-gyro systems engineering. Some circuits are also available as standard components in microelectronics.

Alternative Micro-Gyro Design:

Figure 6 shows an alternative design for a TEZA micro-gyro 110. The second preferred micro-gyro 110 of Figure 6 has many elements in common with the first preferred micro-gyro of Figures 1a and 1b. Accordingly, Applicants have omitted some of the more detailed element labels for clarity and have used similar numbers for similar elements (e.g. 110 versus 10 and 121 versus 21).

A preview of the major differences between the two embodiments may be helpful. Referring back to Figures 1a and 1b, it can be seen that the input elements 70a, 70b are each divided into nearly separate "quarters" owing to a central channel (not numbered) that lets the output flexures 25a, 25b reach the output element 80. The second preferred micro-gyro 110, by contrast, has a simplified flexure design that permits the input elements 170a, 170b to remain nearly "whole." In particular, in the second micro-gyro 110 of Figure 6, the output flexures 125a, 125b

that support the output element 180 are located in the space between the flat sides of the two input elements 170a, 170b, rather than passing through them. An additional benefit of the second preferred micro-gyro 110 is that the input flexures 123a, 123b act like opposed springs and may be mechanically designed such that the input elements 170a, 170b naturally oscillate in opposite phase at a unique resonance, thereby eliminating the need for a separate mechanical linkage 90 (as used between elements 70a, 70b in Figures 1a and 1b).

The second preferred micro-gyro 110 most intuitively begins with a single anchor 121 located at the center of the structure (the embodiment of Figures 1a and 1b has two separate anchors 21a, 21b). A pair of flexure stubs 122a, 122b extend from opposite sides of the anchor 121 to support the input elements 170a, 170b and the output element 180 via other flexures connecting to flexure joints 124a, 124b located at the ends of the stubs. In particular, output flexures 125a, 125b extend radially outward from flexure joints 124a, 124b to support the output element 180. The input elements 170a, 170b are connected to the flexure stubs 122a, 122b and output flexures 125a, 125b at the flexure joints 124a, 124b by input flexures 123a, 123b. The preferred input flexures 123a, 123b have a geometry that provides a spring-like action in the X-direction while being substantially rigid in the Y-direction.

As before, the input elements 170a, 170b are driven into opposed oscillation along the X-direction with electrostatic forces from drive actuation electrodes 130a, 130b. Drive feedback electrodes 140a, 140b are used, if desired, for closed-loop control of the drive oscillation.

When the entire micro-gyro 110 is subject to a rotation about the rate or Z-axis, the input elements 170a, 170b will oscillate in the \pm Y-direction due to Coriolis force. Again, as before, because the oscillations in the X-direction are always in opposite directions, the resulting \pm Y-direction motions are also always in opposite directions. The first and second input elements 170a, 170b having opposite components of motion in the Y-direction combine to create a torque that is directed one way or the other about the Z-axis. This action causes the output element 180 to oscillate. By arranging the natural resonance of the output element 180 to be close to the driving frequency of the input elements 170a, 170b, the small Coriolis signal is amplified by the resonance effect.

Output sensing electrodes 150a, 150b are used to pick off the motion of the output element 180 while output balancing electrodes 160a, 160b are used to provide a force-balance for closed-loop control as described in the previous section.

We Claim:

1. A method of detecting rotational rate about a rate axis by:

vibrating an input element; and

5

vibrating an output element about an axis that is parallel to the rate axis in response to the Coriolis force generated by the input element.

2. A method detecting rotational rate about a rate axis by:

vibrating an input element relative to an input axis at a first frequency;

10

causing the input element to vibrate in response to Coriolis force relative to an output axis at a natural resonance centered on a second frequency that is substantially different from the first frequency such that coriolis-induced vibrations at the first frequency are inefficiently dissipated in the first element; and

15

causing an output element to vibrate in response to Coriolis force relative to an output axis at a natural resonance centered on a third frequency that is substantially the same as the first frequency such that coriolis-induced vibrations at the first frequency are efficiently transferred to and dissipated in the output element.

20

3. A device for detecting rotational rate about a rate axis, comprising:

an input element that vibrates;

an output element that vibrates about an output axis that is parallel with the rate axis; and

25

linkage connecting the input element and the output element to transfer Coriolis force from the input element to the output element.

4. A device for detecting rotational rate about a rate axis, comprising:

an input element that vibrates along an input axis;

30

an output element that vibrates about an output axis that is perpendicular to the input axis; and

linkage connecting the input element to output element to transfer Coriolis force from the input element to the output element.

5 A device for detecting rotational rate about rate axis, comprising:
an input element that that vibrates along an input axis;
an output element that receives Coriolis force from the input element; and
linkage connecting the input element to output element, said linkage
5 redirecting the direction of the Coriolis force such that the output element
 vibrates about an output axis that is parallel with the rate axis.

6. The device of Claim 5 wherein the output axis is coincident with the rate
axis.

10 7. A device for detecting rotational rate about a rate axis, comprising:
A substrate that is perpendicular to the rate axis;
an input element that vibrates in a plane that is parallel to the substrate;
an output element that vibrates in response to Coriolis force from the input
 element; and
15 linkage connecting the input element to the output element such that the
 output element vibrates about an axis that is parallel to the rate axis and
 in a plane that is parallel to the substrate.

20 8. A micro-gyro for detecting rotational movement about a rate axis,
comprising:
 first and second input elements that vibrate in opposition to one another in an
 input direction to generate perpendicular Coriolis force in response to
 rotational movement about the rate axis, the first and second input
 elements vibrating in opposition to one another at or near a resonant
25 frequency in the input direction;
 an output element that receives Coriolis force from the first and second input
 elements to cause the output element to vibrate in an output direction,
 the output element vibrating under Coriolis force at or near its resonant
 frequency in the output direction, which frequency is substantially similar
30 to the resonant frequency of the first and second input elements in the
 input direction in order to enhance transfer of Coriolis force from the first
 and second input elements to the output element; and

first and second flexures connecting the first and second input elements to the output element to transfer Coriolis force, the flexures dynamically coupling the first and second input elements to the output element at one frequency for transferring the Coriolis force, and

5 the linkages dynamically decoupling the first and second input elements from the output element at other frequencies so that vibrating motion of the first and second input elements in the input direction does not cause substantial motion of the element in the input direction.

10 9. The micro-gyro device of Claim 1 wherein the first and second input elements have a resonant frequency in the output direction that is substantially different from the resonant frequency in the input direction.

10. The micro-gyro device of Claim 1 wherein vibrating motion of the output element in the output direction does not cause substantial motion of the first and second input elements.

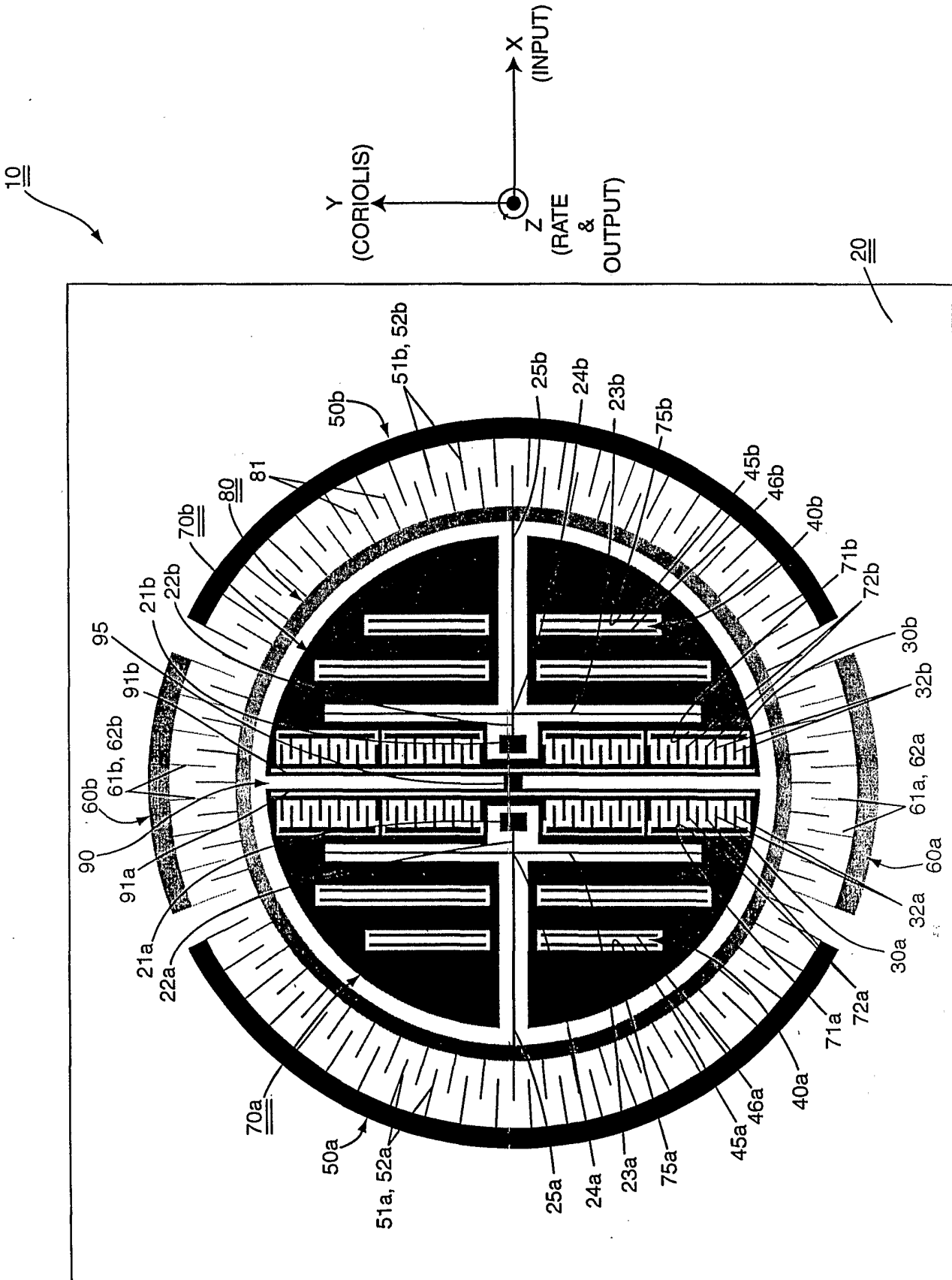

FIG. 1a

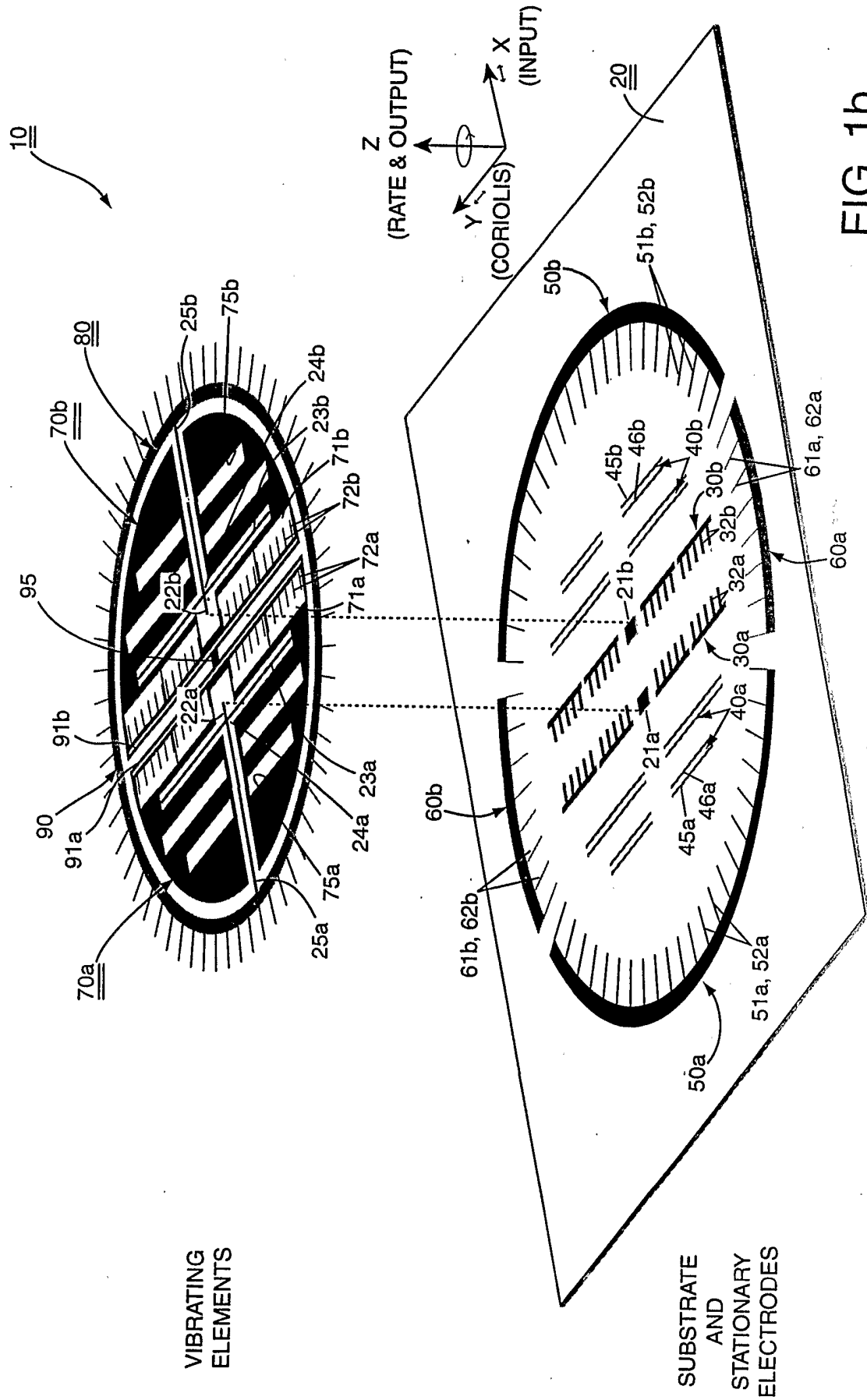

FIG. 1b

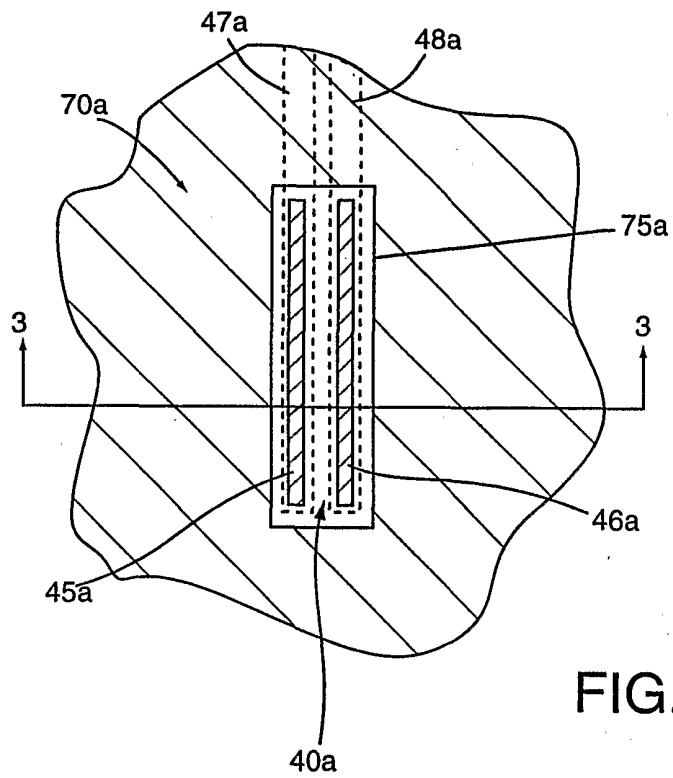

FIG. 2

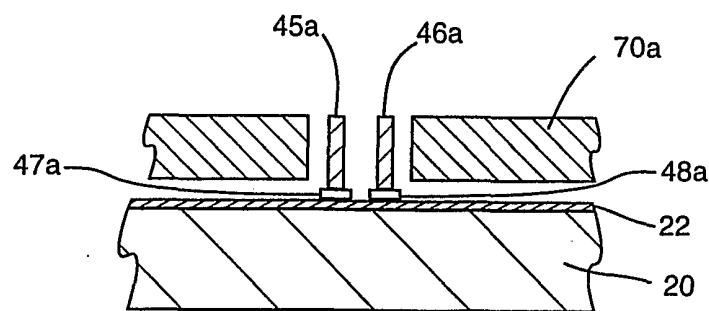

FIG. 3

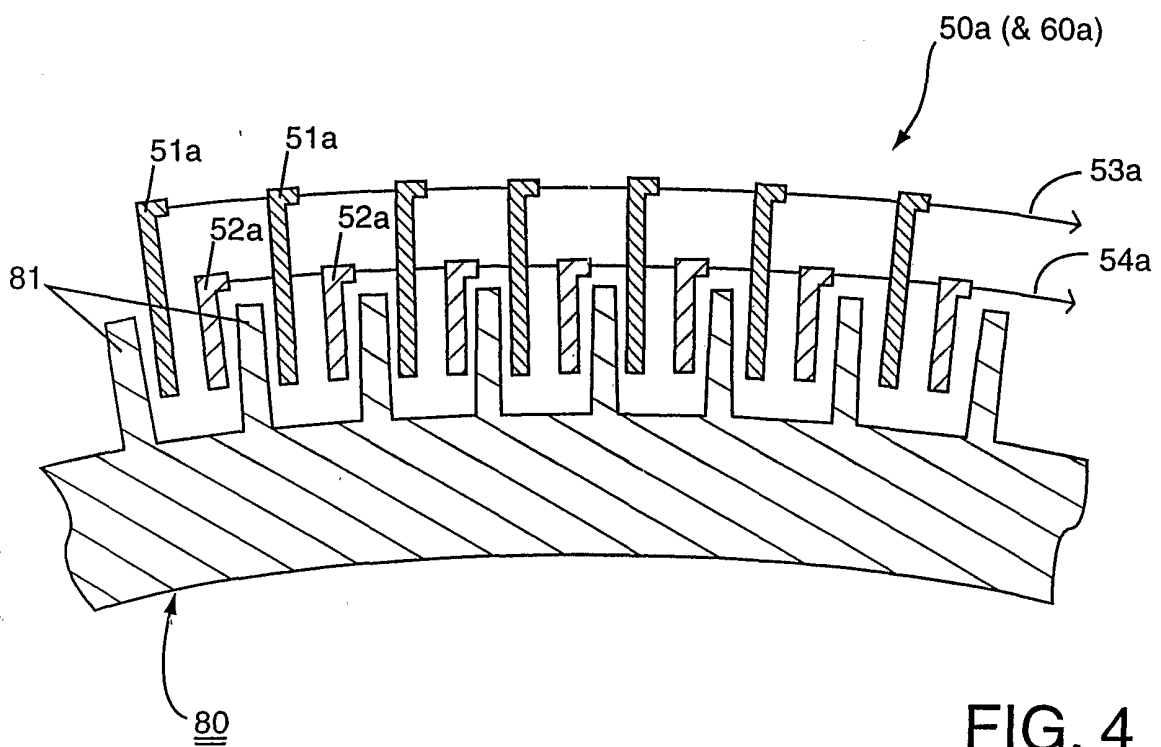

FIG. 4

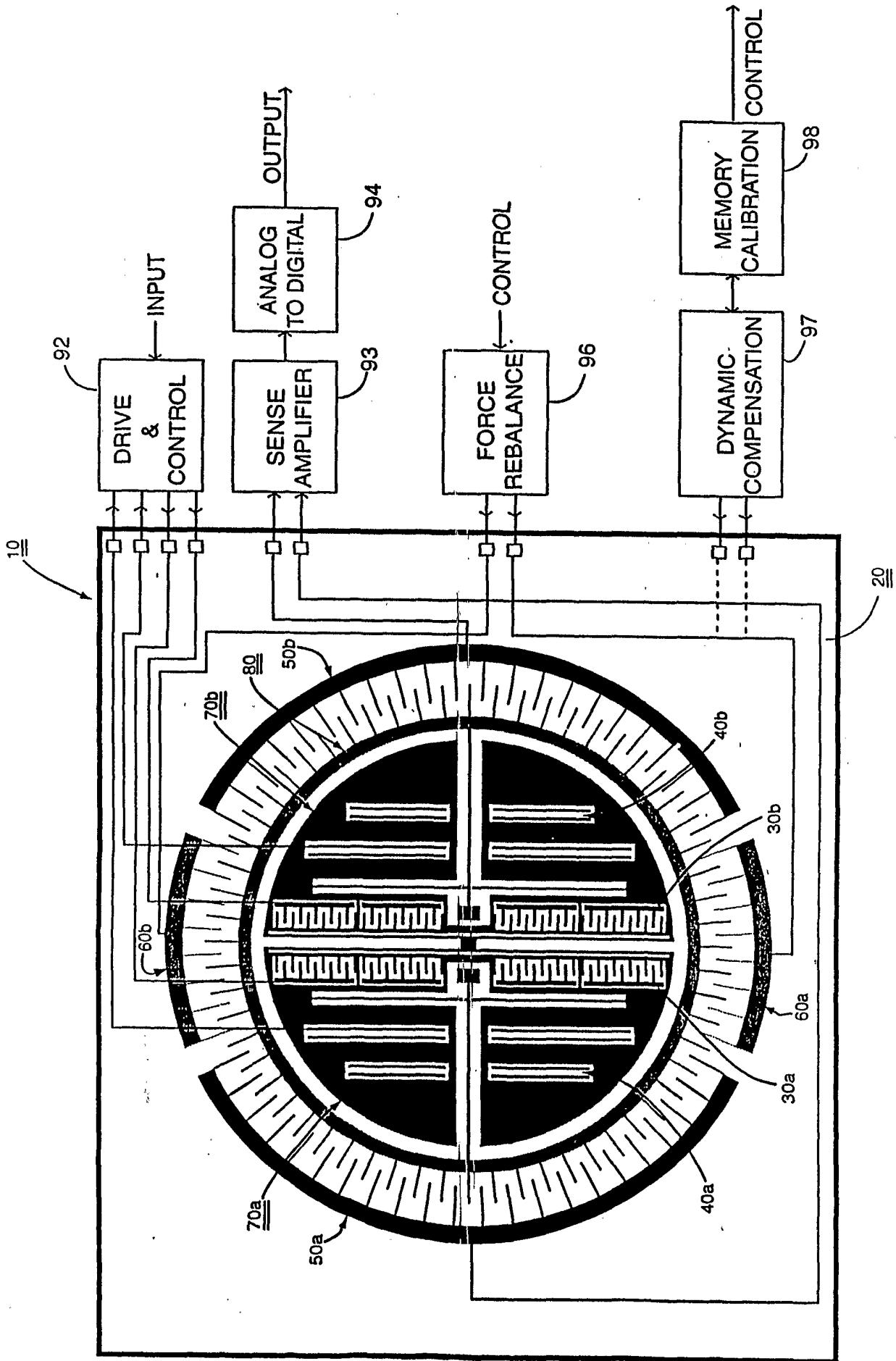

FIG. 5

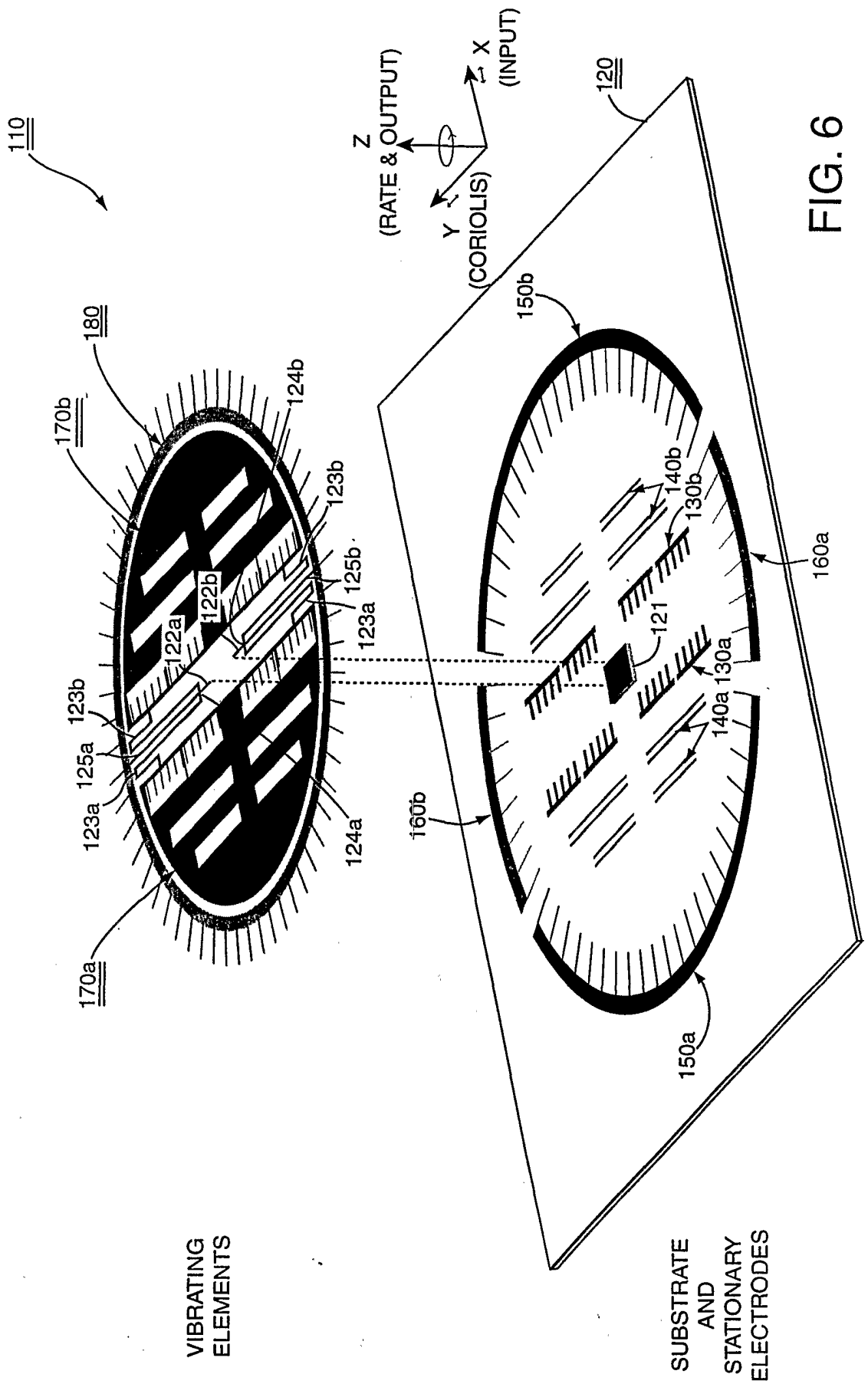

FIG. 6

INTERNATIONAL SEARCH REPORT

International application No.
PCT/US01/08604

A. CLASSIFICATION OF SUBJECT MATTER
 IPC(7) :G01P 9/04
 US CL :73/504.12, 1.37
 According to International Patent Classification (IPC) or to both national classification and IPC

B. FIELDS SEARCHED
 Minimum documentation searched (classification system followed by classification symbols)
 U.S. : 73/504.12, 504.13, 504.14, 504.04, 504.08, 504.09, 1.37

Documentation searched other than minimum documentation to the extent that such documents are included in the fields searched
 NONE

Electronic data base consulted during the international search (name of data base and, where practicable, search terms used)
 EAST
 search terms: Coriolis force, gyro, gyroscope, microgyroscope, microgyro, oscillation

C. DOCUMENTS CONSIDERED TO BE RELEVANT

Category*	Citation of document, with indication, where appropriate, of the relevant passages	Relevant to claim No.
X	US 5,955,668 A (HSU et al.) 21 September 1999, (21/09/99) col. 3, line 31 to col. 5, line 53.	1-10
X, P	US 6,089,089 A (HSU) 18 July 2000, (18/07/00) col. 3, line 6 to col. 5, line 52.	1-10
A	US 5,408,877 A (GREIFF et al.) 25 April 1995, (25/04/95) col. 3, line 46 to col. 4, line 39.	1-10
A	US 5,635,640 (GEEN) 03 June 1997, (03/06/97) col. 2, line 58 to col. 3, line 64.	1-10
A	US 5,650,568 (GREIFF et al.) 22 July 1997, (22/07/97) col. 4, line 62 to col. 6, line 67.	1-10

Further documents are listed in the continuation of Box C. See patent family annex.

* Special categories of cited documents:	"T" later document published after the international filing date or priority date and not in conflict with the application but cited to understand the principle or theory underlying the invention
"A" document defining the general state of the art which is not considered to be of particular relevance	"X" document of particular relevance; the claimed invention cannot be considered novel or cannot be considered to involve an inventive step when the document is taken alone
"E" earlier document published on or after the international filing date	"Y" document of particular relevance; the claimed invention cannot be considered to involve an inventive step when the document is combined with one or more other such documents, such combination being obvious to a person skilled in the art
"L" document which may throw doubts on priority claim(s) or which is cited to establish the publication date of another citation or other special reason (as specified)	"&" document member of the same patent family
"O" document referring to an oral disclosure, use, exhibition or other means	
"P" document published prior to the international filing date but later than the priority date claimed	

Date of the actual completion of the international search 18 MAY 2001	Date of mailing of the international search report 14 June 2001
--	--

Name and mailing address of the ISA/US Commissioner of Patents and Trademarks Box PCT Washington, D.C. 20231 Facsimile No. (703) 305-3230	Authorized officer HELEN C. KWOK <i>Helen Kwok</i> Telephone No. (703) 305-4900
---	---

INTERNATIONAL SEARCH REPORT

International application No.
PCT/US01/08604

C (Continuation). DOCUMENTS CONSIDERED TO BE RELEVANT		
Category*	Citation of document, with indication, where appropriate, of the relevant passages	Relevant to claim No.
A	US 5,728,936 A (LUTZ) 17 March 1998, (17/03/98) col. 2, line 21 to col. 3, line 60.	1-10