



US00D363588S

United States Patent [19]

[11] Patent Number: **Des. 363,588**

Bancroft et al.

[45] Date of Patent: ****Oct. 24, 1995**

[54] BATTERY CART

[75] Inventors: **Allen J. Bancroft**, Elkhart; **Romeo L. Datu-on**, South Bend; **Jeff M. Killian**, Nappanee, all of Ind.

[73] Assignee: **White Consolidated Industries, Inc.**, Cleveland, Ohio

[**] Term: **14 Years**

[21] Appl. No.: **26,469**

[22] Filed: **Jul. 28, 1994**

[52] U.S. Cl. **D34/17; D34/12**

[58] Field of Search **D34/12, 17, 20, D34/21, 24, 26, 23; 280/47.35, 79.11, 47.34, 47.18, 47.19, 47.28, 651**

[56] References Cited

U.S. PATENT DOCUMENTS

D. 307,209 4/1990 Gallagher D34/12

FOREIGN PATENT DOCUMENTS

1500291 9/1966 France 280/47.18

Primary Examiner—Kay H. Chin
Attorney, Agent, or Firm—Pearne, Gordon McCoy & Granger

[57] CLAIM

The ornamental design for a battery cart, as shown and described.

DESCRIPTION

FIG. 1 is a front perspective view of a battery cart, showing our new design;
FIG. 2 is a right side elevational view thereof;
FIG. 3 is a top plan view thereof;
FIG. 4 is a back side elevational view thereof;
FIG. 5 is a front side elevational view thereof;
FIG. 6 is a left side elevational view thereof; and,
FIG. 7 is a bottom plan view thereof.

1 Claim, 4 Drawing Sheets

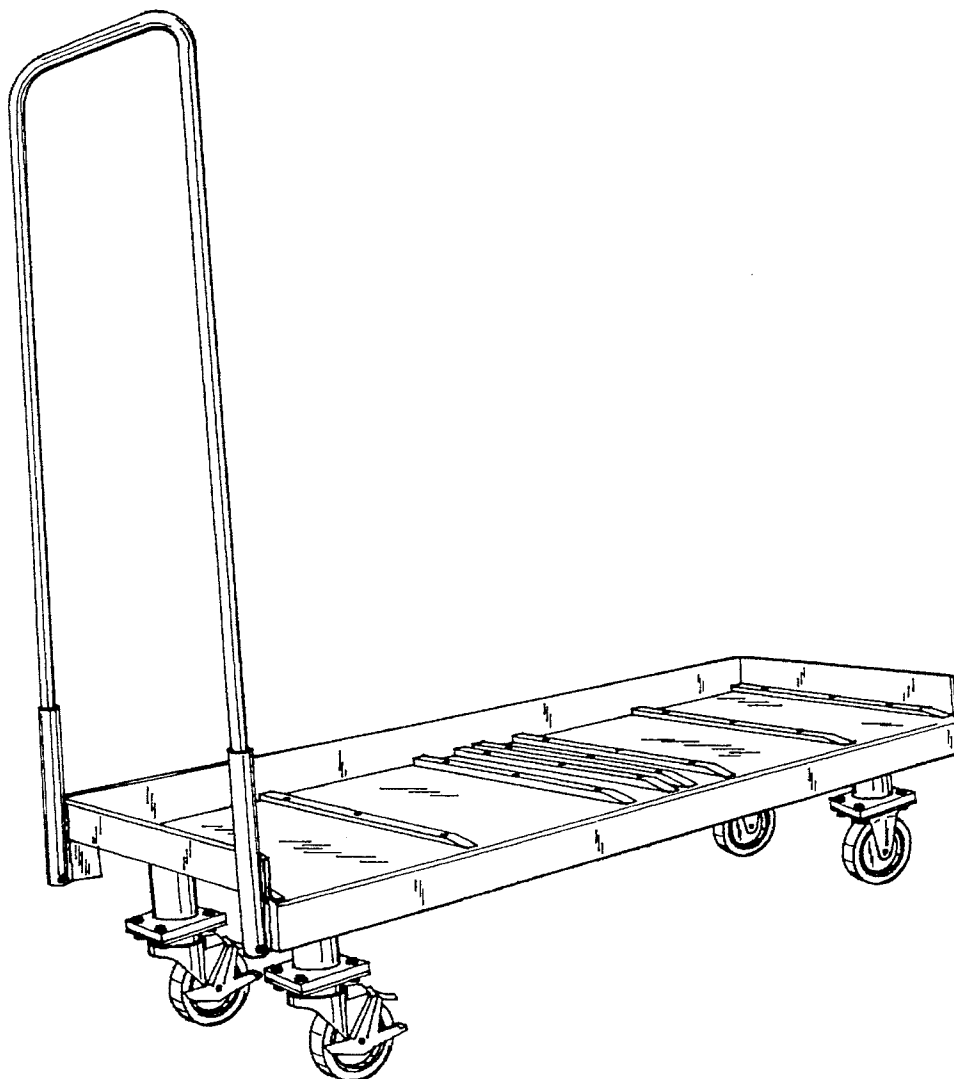
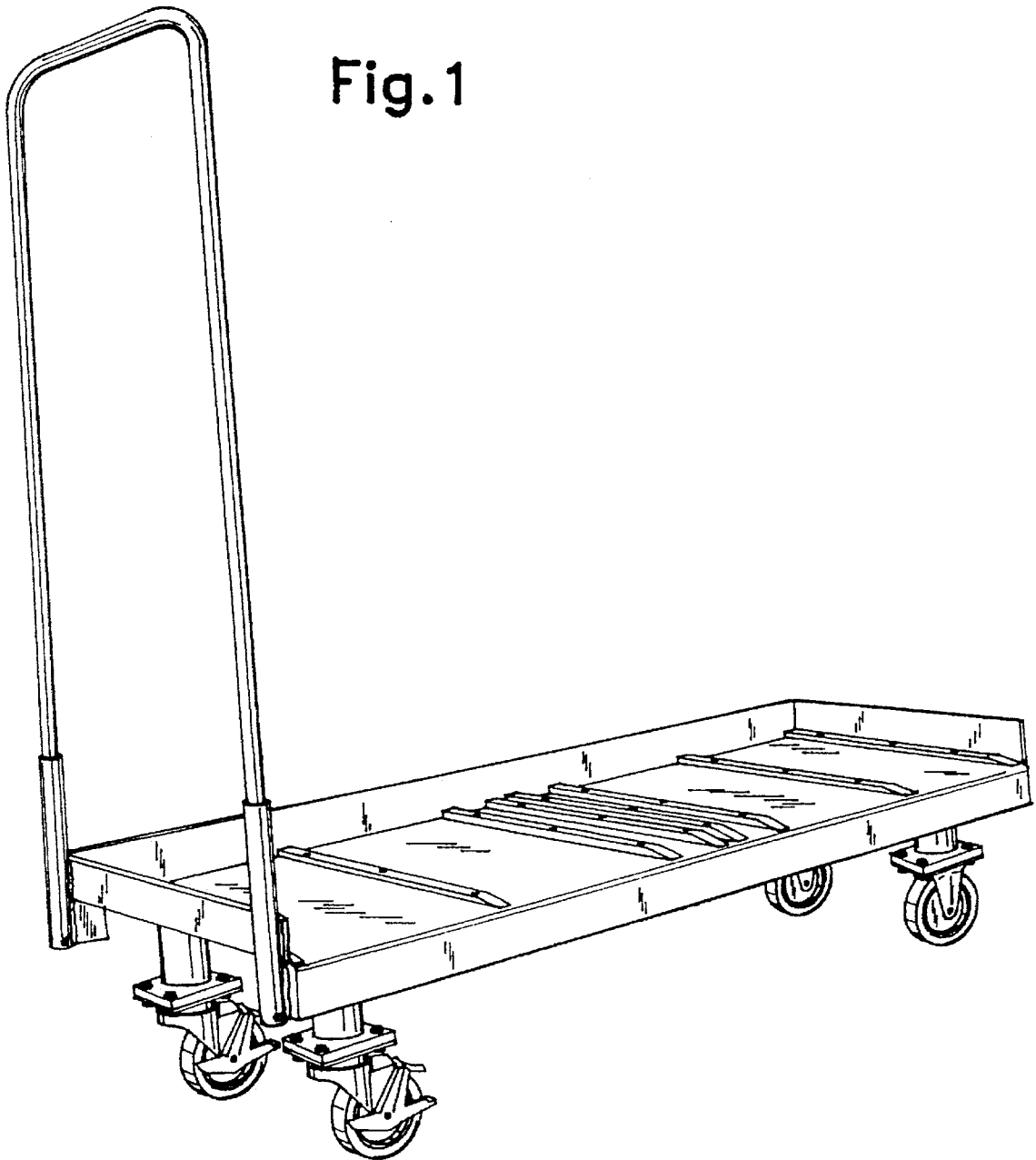

Fig. 1



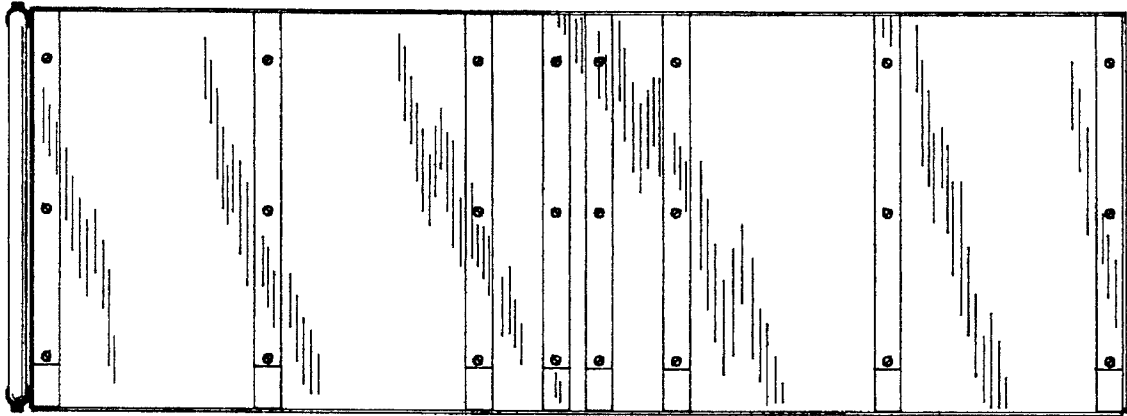

Fig.3

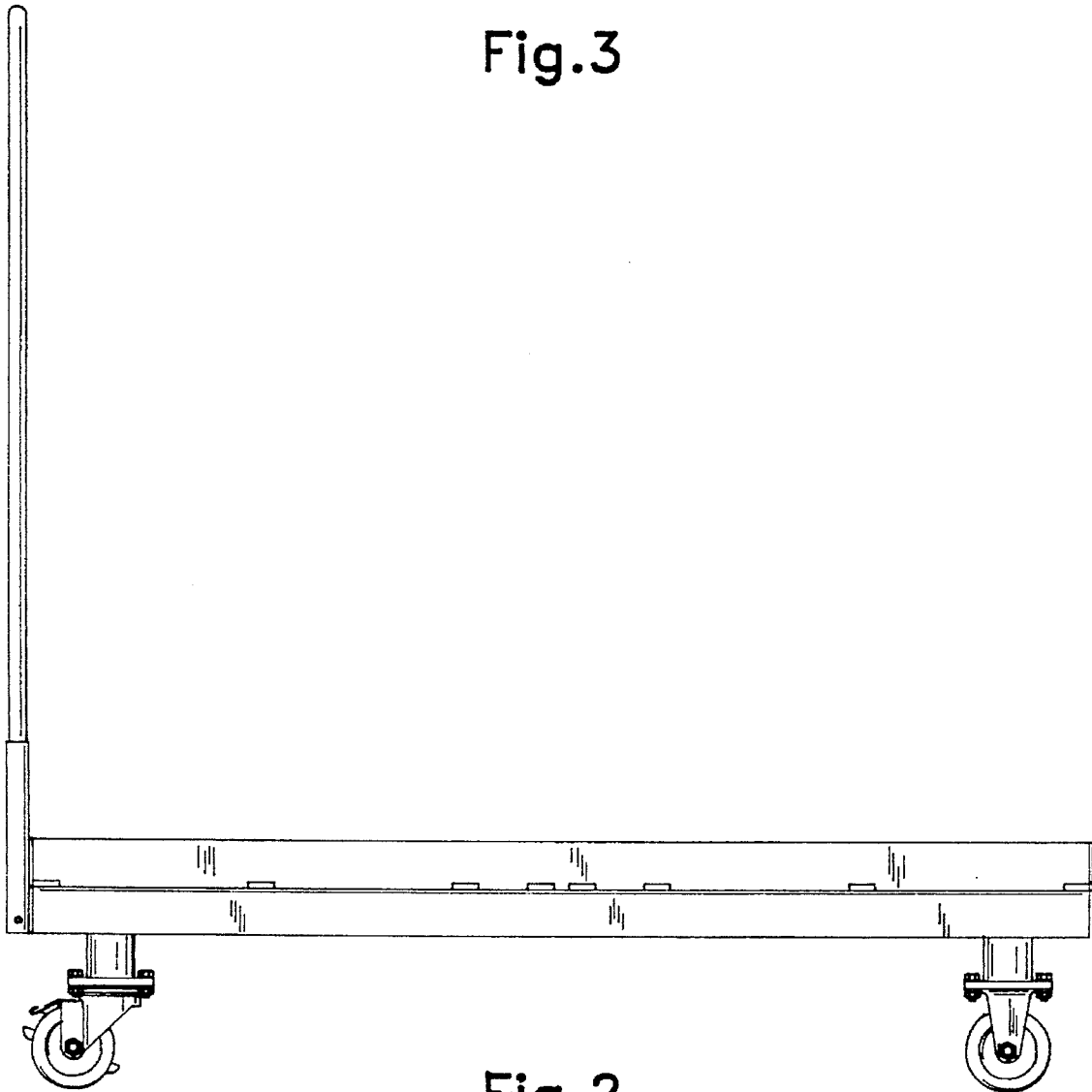

Fig.2

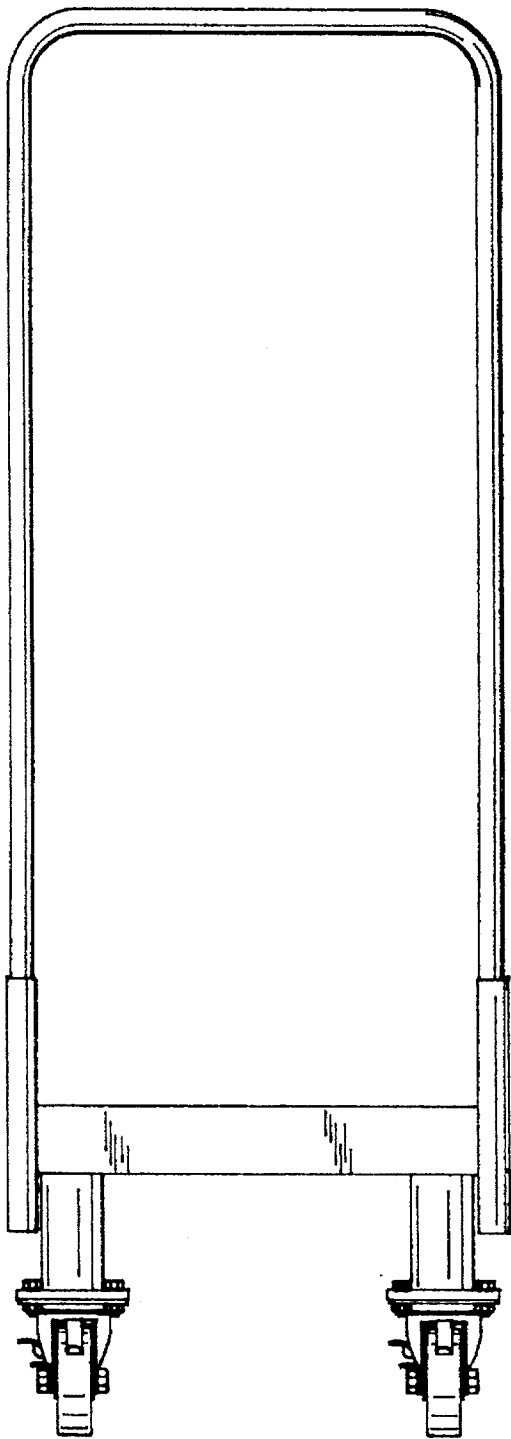

Fig. 5

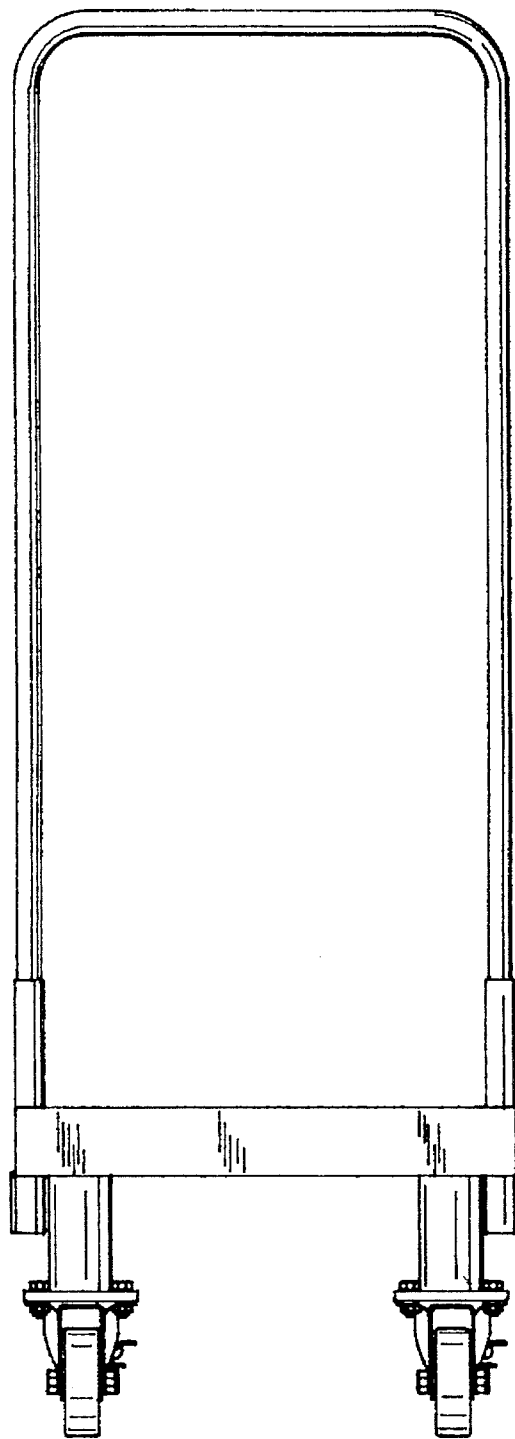

Fig. 4

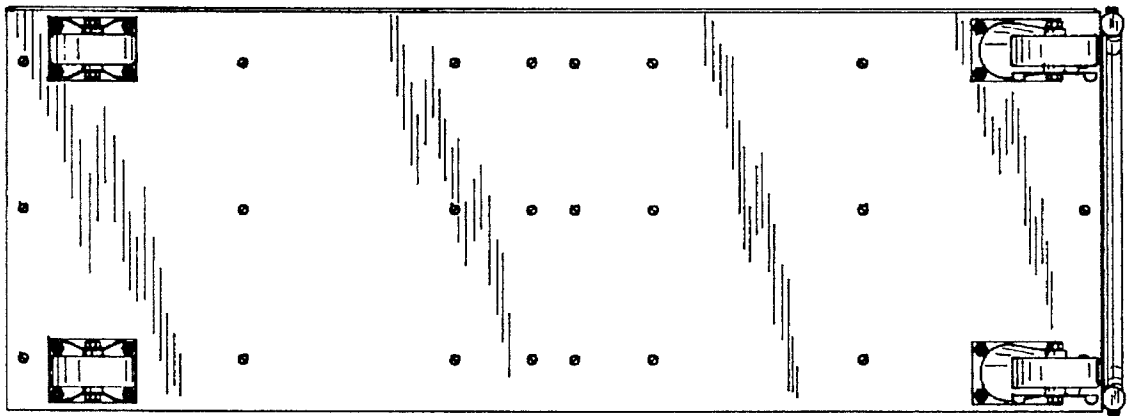

Fig.7

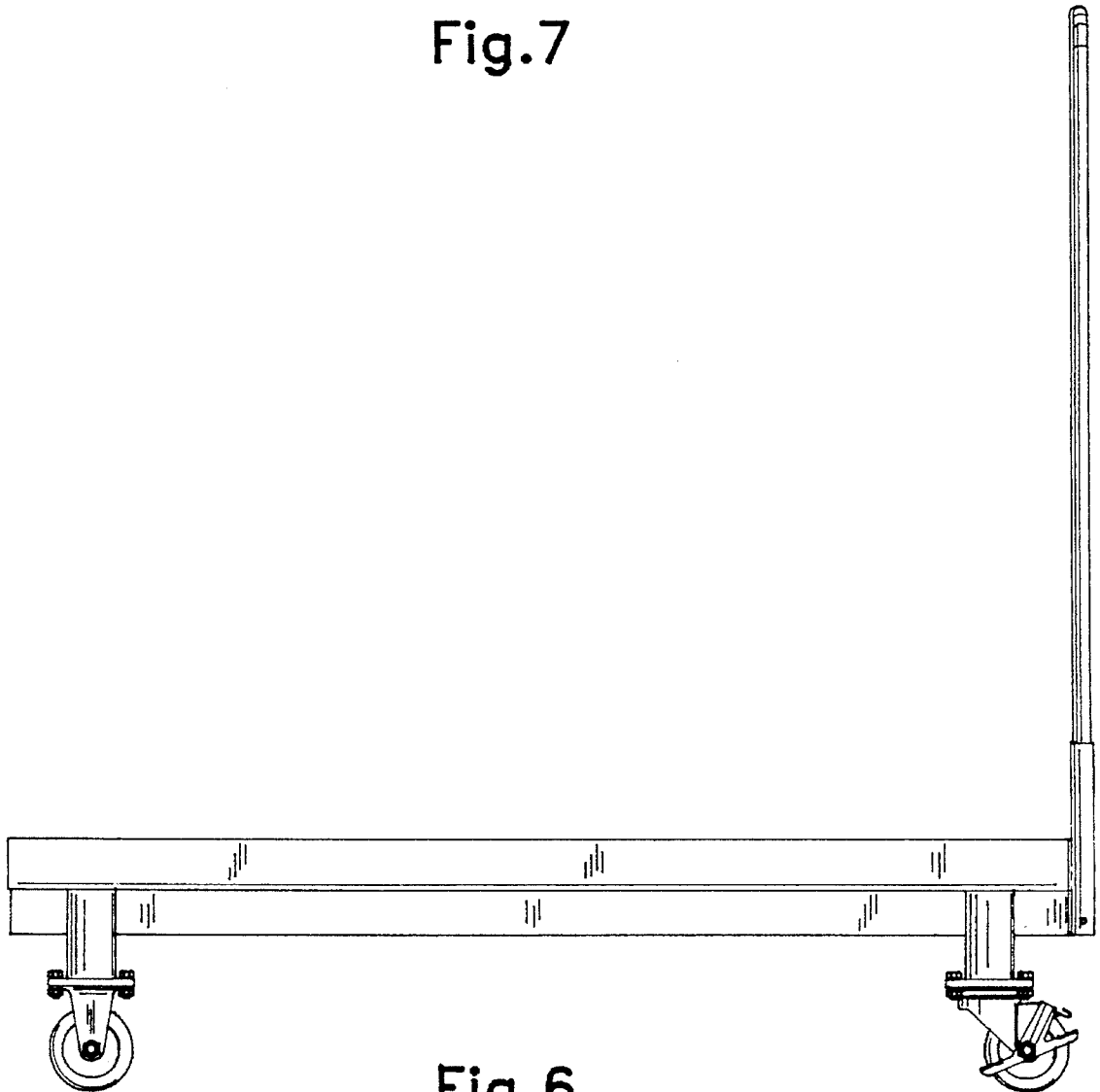

Fig.6