



US00D740757S

(12) **United States Design Patent**
Scholeno

(10) **Patent No.:** **US D740,757 S**

(45) **Date of Patent:** **** Oct. 13, 2015**

(54) **VERTICAL ELECTRICAL CONNECTOR**

(71) Applicant: **Michael Scholeno**, York, PA (US)

(72) Inventor: **Michael Scholeno**, York, PA (US)

(73) Assignee: **FCI AMERICAS TECHNOLOGY LLC**, Carson City, NV (US)

(**) Term: **14 Years**

(21) Appl. No.: **29/507,836**

(22) Filed: **Oct. 31, 2014**

Related U.S. Application Data

(62) Division of application No. 29/418,380, filed on Apr. 16, 2012, now Pat. No. Des. 718,243.

(51) **LOC (10) CI.** **13-03**

(52) **U.S. CI.**

USPC **D13/147**

(58) **Field of Classification Search**

USPC D13/147, 154, 184, 199; 439/74, 108, 439/180, 246, 252, 278, 374, 378, 379, 381, 439/527, 529, 533, 660, 717, 865-894, 439/953; 174/16.3; 257/697, 727; 361/769
See application file for complete search history.

(56) **References Cited**

U.S. PATENT DOCUMENTS

D205,509 S	8/1966	Reynolds	
D210,829 S	4/1968	Hanlon et al.	
D497,343 S	10/2004	Busse et al.	
D598,389 S	8/2009	Yu et al.	
D608,292 S	1/2010	Stutz	
D611,906 S	3/2010	Takada et al.	
D611,907 S	3/2010	Takada et al.	
D718,243 S *	11/2014	Scholeno D13/147
D718,244 S	11/2014	Scholeno	

D718,248 S	11/2014	Harper, Jr.
D718,249 S	11/2014	Lord et al.
D718,250 S	11/2014	Lord
2004/0161954 A1	8/2004	Johnescu et al.
2006/0160425 A1	7/2006	Fuerst
2012/0034820 A1	2/2012	Lang et al.
2012/0258633 A1	10/2012	Johnson et al.

OTHER PUBLICATIONS

SFF-Committee, "Mini Multilane 12 Gbs 8/4X Unshielded Connector," SFF-8643 Rev 2.3, Jan. 11, 2011, 24 pages.

* cited by examiner

Primary Examiner — Daniel Bui

(74) *Attorney, Agent, or Firm* — Baker & Hostetler LLP

(57) **CLAIM**

The ornamental design for a vertical electrical connector, as shown and described.

DESCRIPTION

FIG. 1 is a top, right, front perspective view of a vertical electrical connector according to an embodiment of my design;

FIG. 2 is a bottom, left, front perspective view thereof;

FIG. 3 is a bottom, left, rear perspective view thereof;

FIG. 4 is a left side elevation view thereof;

FIG. 5 is a right side elevation view thereof;

FIG. 6 is a front elevation view thereof;

FIG. 7 is a rear elevation view thereof;

FIG. 8 is a top plan view thereof; and,

FIG. 9 is a bottom plan view thereof.

The even-broken line in the figure drawings is included to show unclaimed environment and forms no part of the claimed design. The dash-dot broken line represents the boundary of the claimed design.

1 Claim, 5 Drawing Sheets

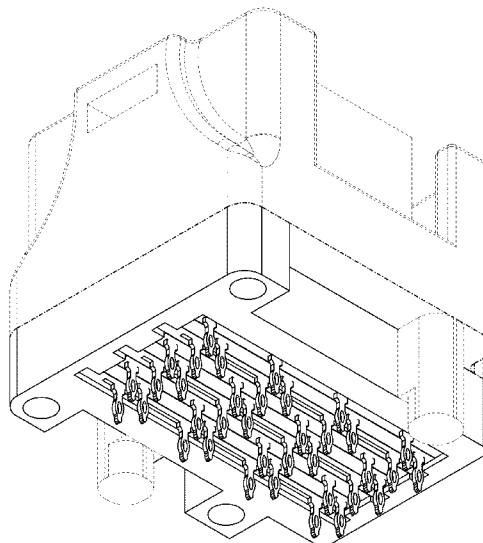
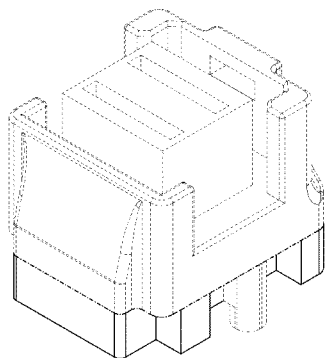

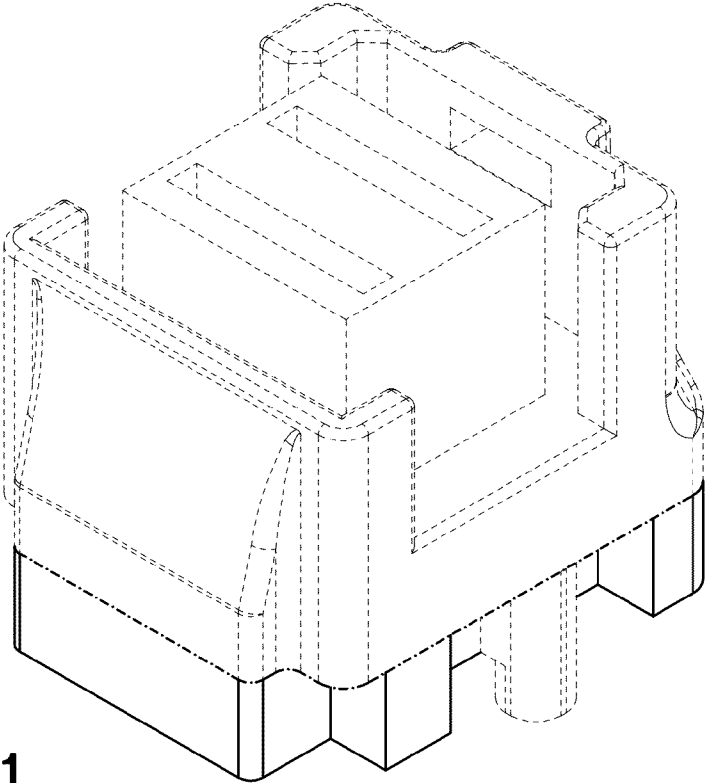

Fig.1

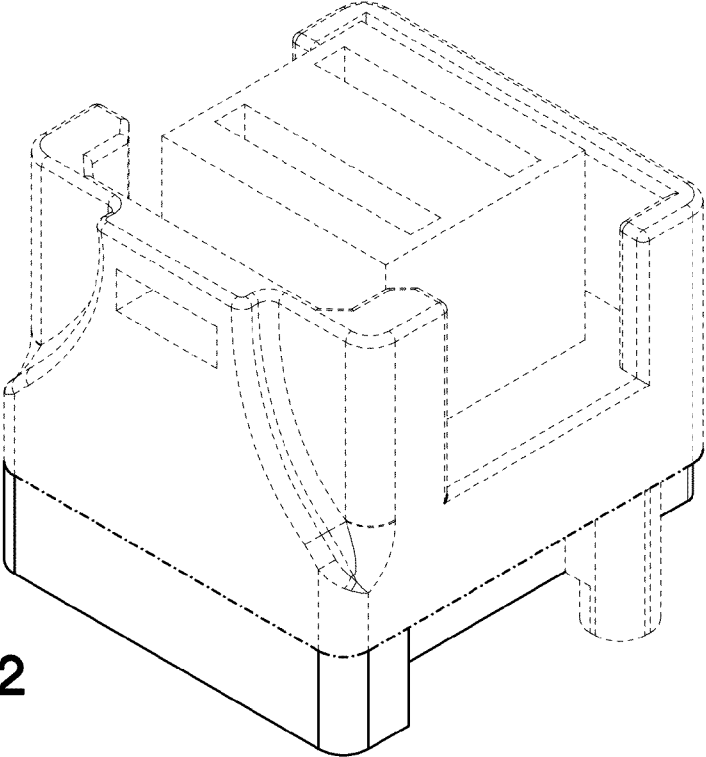

Fig.2

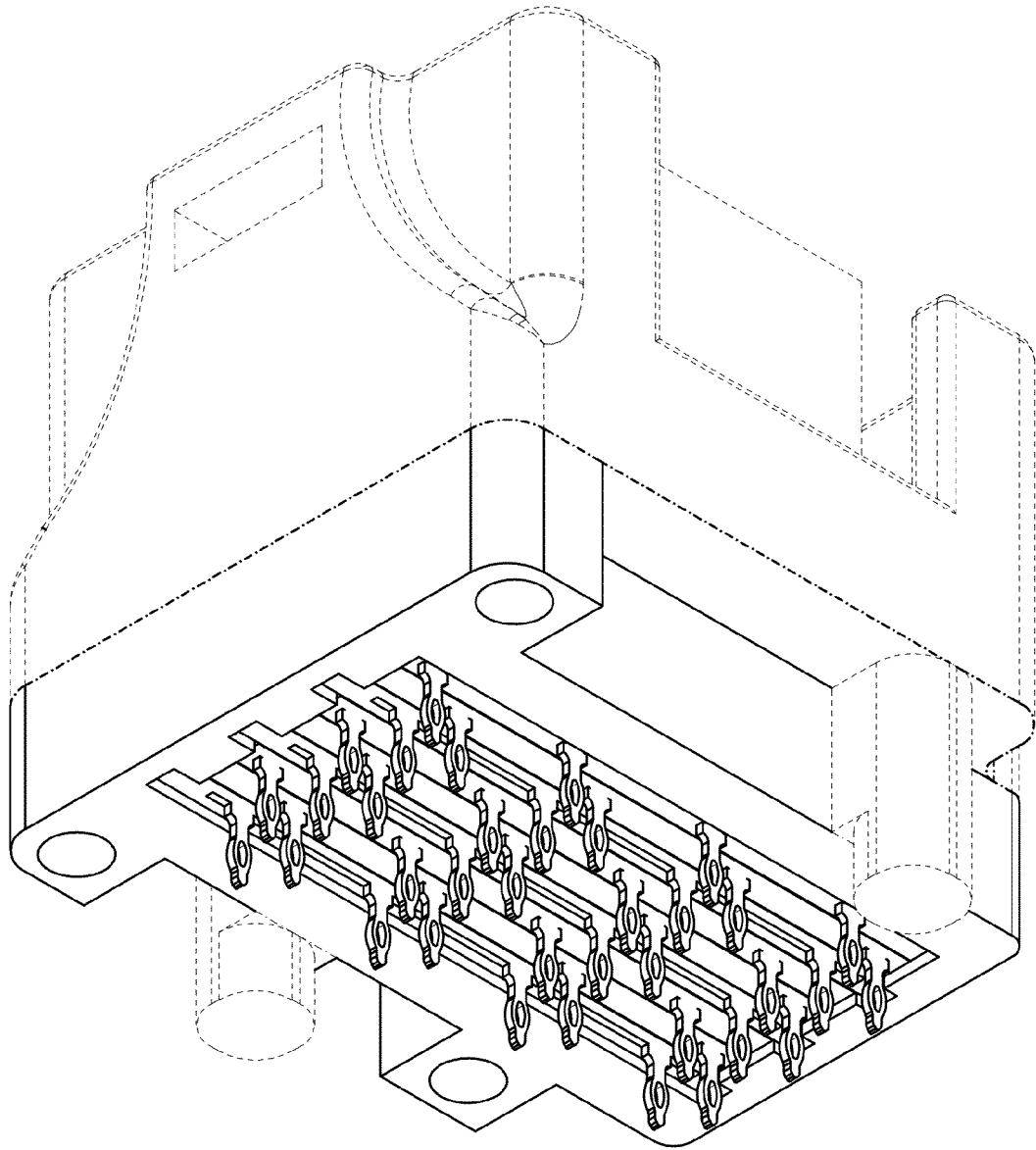

Fig.3

Fig.4

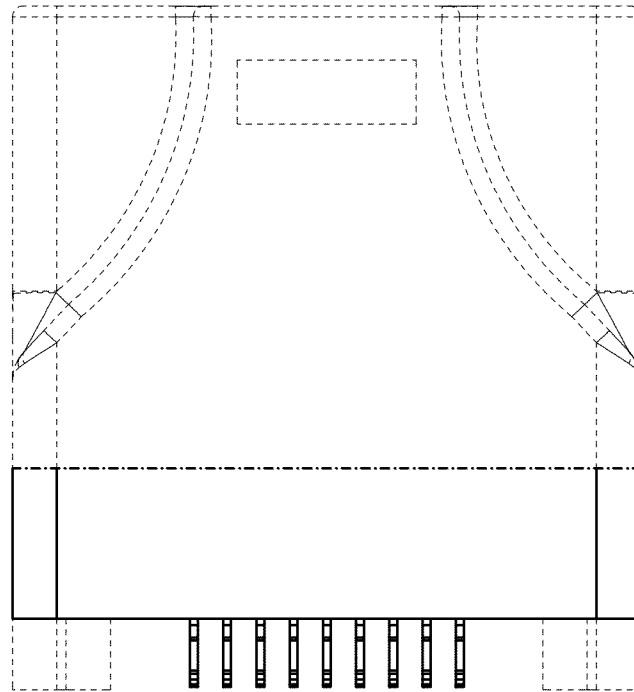

Fig.5

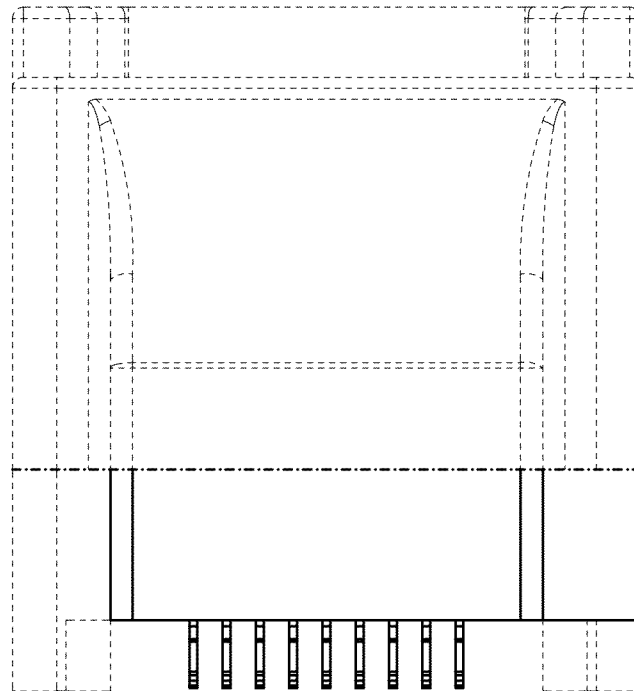

Fig.6

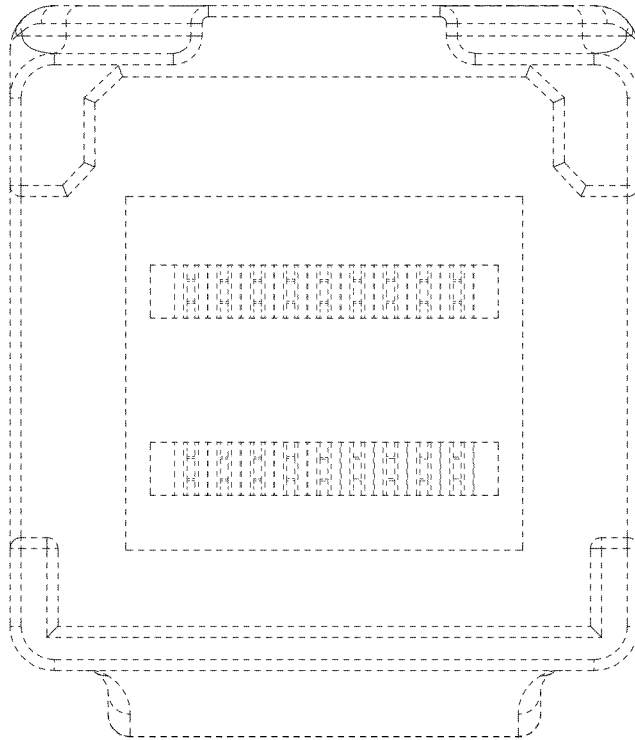

Fig.7

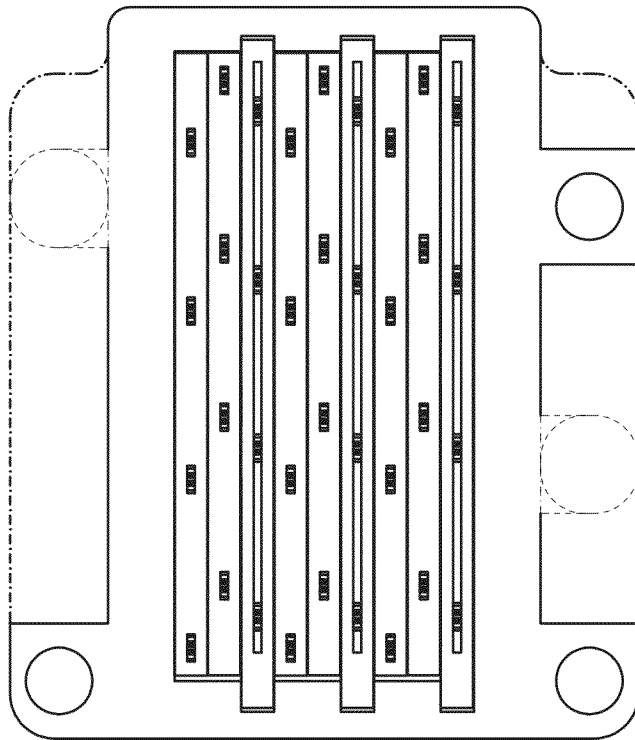

Fig.8

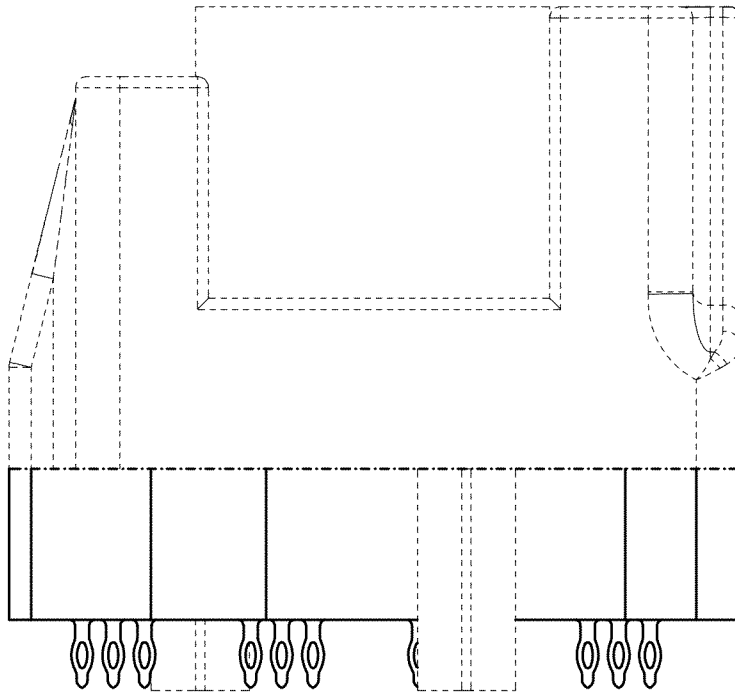

Fig.9

