



US00D965150S

(12) **United States Design Patent**
Courtney et al.

(10) **Patent No.:** **US D965,150 S**

(45) **Date of Patent:** **** Sep. 27, 2022**

(54) **PROSTHESIS ANCHOR**

FOREIGN PATENT DOCUMENTS

(71) Applicant: **HOWMEDICA OSTEONICS CORP.**,
Mahwah, NJ (US)

DE 4220217 12/1993
DE 10233204 1/2004

(Continued)

(72) Inventors: **Robert Courtney**, Pierceton, IN (US);
Austin W. Mutchler, Warsaw, IN (US);
Jeffrey M. Ondrla, Warsaw, IN (US)

OTHER PUBLICATIONS

Final Rejection issued in connection with U.S. Appl. No. 16/208,956,
dated Apr. 30, 2021, 13 pages.

(Continued)

(73) Assignee: **HOWMEDICA OSTEONICS CORP.**,
Mahwah, NJ (US)

Primary Examiner — Charles D Hanson

(74) *Attorney, Agent, or Firm* — Duane Morris LLP

(**) Term: **15 Years**

(21) Appl. No.: **29/673,310**

(57) **CLAIM**

The ornamental design for prosthesis anchor, as shown and
described.

(22) Filed: **Dec. 13, 2018**

DESCRIPTION

Related U.S. Application Data

(62) Division of application No. 29/544,231, filed on Oct.
30, 2015, now Pat. No. Des. 840,539, which is a
(Continued)

(51) **LOC (13) Cl.** **24-03**

(52) **U.S. Cl.**
USPC **D24/155**

(58) **Field of Classification Search**
USPC D24/155
CPC A61F 2/3859; A61F 2/38; A61F 2/389;
A61F 2/3886; A61F 2/60; A61F 2/06;
A61F 2/66; A61F 2/76; A61F 2310/00023
See application file for complete search history.

FIG. 1 is a top perspective view of an embodiment;
FIG. 2 is a bottom perspective view of the embodiment of
FIG. 1;
FIG. 3 is a front view of the embodiment of FIG. 1;
FIG. 4 is a back view of the embodiment of FIG. 1;
FIG. 5 is a left side view of the embodiment of FIG. 1;
FIG. 6 is a right side view of the embodiment of FIG. 1;
FIG. 7 is a top view of the embodiment of FIG. 1; and
FIG. 8 is a bottom view of the embodiment of FIG. 1.
FIG. 9 is a top perspective view of another embodiment;
FIG. 10 is a bottom perspective view of the embodiment of
FIG. 9;
FIG. 11 is a front view of the embodiment of FIG. 9;
FIG. 12 is a back view of the embodiment of FIG. 9;
FIG. 13 is a left side view of the embodiment of FIG. 9;
FIG. 14 is a right side view of the embodiment of FIG. 9;
FIG. 15 is a top view of the embodiment of FIG. 9; and,
FIG. 16 is a bottom view of the embodiment of FIG. 9.
The broken lines are included for purposes of illustrating
such portion of the prosthesis anchor and form no part of the
claimed design.

(56) **References Cited**

U.S. PATENT DOCUMENTS

448,126 A 3/1891 Craig
1,065,456 A 6/1913 Lowrey
(Continued)

1 Claim, 16 Drawing Sheets

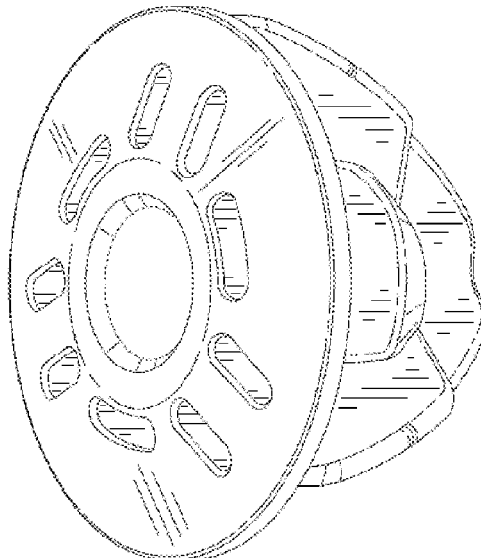

Related U.S. Application Data

division of application No. 29/456,077, filed on May 28, 2013, now Pat. No. Des. 745,678, which is a division of application No. 29/365,240, filed on Jul. 6, 2010, now Pat. No. Des. 685,474.

(56)

References Cited

U.S. PATENT DOCUMENTS

1,123,730 A 1/1915 Greenfield
 2,444,099 A 6/1948 Hennessey, Jr.
 2,886,081 A 5/1959 Cowley
 3,523,395 A 8/1970 Rutter et al.
 3,609,056 A 9/1971 Hougen
 3,738,217 A 6/1973 Walker
 4,042,980 A * 8/1977 Swanson A61F 2/40
 623/19.13
 4,147,464 A 4/1979 Watson et al.
 4,250,600 A 2/1981 Gunther
 4,261,062 A 4/1981 Amstutz et al.
 4,406,023 A 9/1983 Harris
 4,550,450 A * 11/1985 Kinnett A61F 2/40
 623/20.11
 4,623,353 A 11/1986 Buechel et al.
 4,632,111 A 12/1986 Roche
 4,743,262 A 5/1988 Tronzo
 4,865,605 A 9/1989 Dines et al.
 4,883,491 A 11/1989 Mallory et al.
 4,919,670 A 4/1990 Dale et al.
 4,964,865 A 10/1990 Burkhead et al.
 4,986,833 A 1/1991 Worland
 5,026,373 A 6/1991 Ray et al.
 5,032,132 A 7/1991 Matsen et al.
 5,044,393 A 9/1991 Jiles
 5,080,673 A 1/1992 Burkhead et al.
 5,112,338 A 5/1992 Anspach, III
 5,163,964 A 11/1992 Lazzeri et al.
 5,171,277 A 12/1992 Roger
 5,257,995 A 11/1993 Umber et al.
 5,282,865 A 2/1994 Dong
 5,358,526 A * 10/1994 Tornier A61F 2/4014
 623/19.14
 5,489,309 A 2/1996 Lackey et al.
 5,489,310 A 2/1996 Mikhail
 5,507,817 A 4/1996 Craig et al.
 5,540,697 A 7/1996 Rehmann et al.
 5,658,290 A 8/1997 Lechot
 5,681,134 A 10/1997 Ebert
 5,702,486 A 12/1997 Craig et al.
 5,723,018 A 3/1998 Cyprien et al.
 5,776,194 A 7/1998 Mikol et al.
 5,800,551 A 9/1998 Williamson et al.
 5,810,524 A 9/1998 Wirth, Jr. et al.
 5,820,315 A 10/1998 Collard
 5,830,215 A 11/1998 Incavo et al.
 5,904,688 A 5/1999 Gilbert et al.
 5,954,727 A 9/1999 Collazo
 5,976,148 A 11/1999 Charpenet et al.
 6,045,582 A 4/2000 Prybyla
 6,063,124 A 5/2000 Amstutz
 6,099,214 A 8/2000 Lee et al.
 6,132,469 A 10/2000 Schroeder
 6,139,551 A 10/2000 Michelson et al.
 6,146,423 A * 11/2000 Cohen A61F 2/3877
 623/20.2
 6,174,335 B1 1/2001 Varietur et al.
 6,187,012 B1 2/2001 Masini
 6,197,063 B1 3/2001 Dews
 6,264,299 B1 7/2001 Noda
 6,264,657 B1 7/2001 Urbahns et al.
 6,306,171 B1 10/2001 Conzemius
 6,364,910 B1 4/2002 Shultz et al.
 6,368,271 B1 4/2002 Sharratt
 6,368,353 B1 4/2002 Arcand
 6,379,917 B1 4/2002 Okun et al.
 6,409,730 B1 6/2002 Green et al.

6,508,840 B1 1/2003 Rockwood, Jr. et al.
 6,520,994 B2 2/2003 Nogarín
 6,537,278 B1 3/2003 Johnson
 6,666,874 B2 12/2003 Heitzmann et al.
 6,736,851 B2 5/2004 Maroney et al.
 6,746,452 B2 6/2004 Tuke et al.
 6,783,549 B1 8/2004 Stone et al.
 6,786,684 B1 9/2004 Ecker
 6,797,006 B2 9/2004 Hodorek et al.
 7,044,973 B2 5/2006 Rockwood, Jr. et al.
 7,097,663 B1 8/2006 Nicol et al.
 7,140,087 B1 11/2006 Giltner
 7,160,328 B2 1/2007 Rockwood, Jr. et al.
 7,169,184 B2 1/2007 Dalla Pria
 7,175,663 B1 2/2007 Stone
 7,179,084 B1 2/2007 Kometas
 7,189,036 B1 3/2007 Watson
 7,189,261 B2 3/2007 Dews et al.
 7,204,854 B2 4/2007 Guederian et al.
 7,208,222 B2 4/2007 Rolfe et al.
 7,344,565 B2 3/2008 Seyer et al.
 7,465,319 B2 * 12/2008 Tornier A61F 2/32
 623/19.11
 7,476,228 B2 1/2009 Abou
 7,476,253 B1 1/2009 Craig et al.
 7,585,327 B2 9/2009 Winslow
 7,615,080 B2 * 11/2009 Ondrla A61F 2/4014
 623/19.11
 7,637,703 B2 12/2009 Khangar et al.
 7,648,530 B2 1/2010 Habermeyer et al.
 7,670,382 B2 * 3/2010 Parrott A61F 2/4003
 623/19.11
 7,678,150 B2 * 3/2010 Tornier A61F 2/40
 623/19.13
 7,744,602 B2 6/2010 Teeny et al.
 7,758,650 B2 7/2010 Dews et al.
 7,887,544 B2 * 2/2011 Tornier A61B 17/1778
 606/96
 7,927,376 B2 4/2011 Leisinger et al.
 D643,926 S * 8/2011 Collins D24/155
 8,021,370 B2 9/2011 Fenton et al.
 8,114,089 B2 2/2012 Divoux et al.
 8,162,947 B2 4/2012 Dreyfuss
 8,182,541 B2 5/2012 Long et al.
 8,187,282 B2 5/2012 Tornier et al.
 8,192,497 B2 6/2012 Ondrla
 8,202,275 B2 6/2012 Wozencroft
 8,221,037 B2 7/2012 Neitzell
 8,231,682 B2 * 7/2012 Lafosse A61F 2/4684
 623/19.11
 8,246,687 B2 * 8/2012 Katrana A61F 2/4014
 623/19.13
 8,277,512 B2 10/2012 Parrott et al.
 8,317,871 B2 11/2012 Stone et al.
 8,409,798 B2 4/2013 Luy et al.
 8,419,798 B2 4/2013 Ondrla et al.
 D685,474 S * 7/2013 Courtney, Jr. D24/155
 8,500,744 B2 8/2013 Wozencroft et al.
 8,506,638 B2 8/2013 Vanasse et al.
 8,512,410 B2 8/2013 Metcalfe et al.
 8,545,506 B2 10/2013 Long et al.
 8,591,592 B2 11/2013 Dreyfuss
 8,641,773 B2 2/2014 Bergin et al.
 8,690,958 B2 4/2014 Klawitter et al.
 8,702,800 B2 4/2014 Linares et al.
 8,753,402 B2 6/2014 Winslow et al.
 8,840,671 B2 9/2014 Ambacher
 8,845,742 B2 9/2014 Kusogullari et al.
 8,864,834 B2 10/2014 Boileau et al.
 8,870,962 B2 10/2014 Roche et al.
 8,876,908 B2 11/2014 Katrana et al.
 8,882,845 B2 11/2014 Wirth et al.
 D745,678 S * 12/2015 Courtney D24/155
 9,233,003 B2 1/2016 Roche et al.
 9,289,218 B2 3/2016 Courtney, Jr. et al.
 9,326,865 B2 5/2016 Katrana et al.
 9,498,345 B2 11/2016 Burkhead, Jr. et al.
 D840,539 S 2/2019 Courtney et al.
 10,456,264 B2 10/2019 Hodorek et al.

(56)

References Cited

U.S. PATENT DOCUMENTS

10,463,499	B2	11/2019	Emerick et al.
11,229,524	B2	1/2022	Sperling
2001/0034553	A1	10/2001	Michelson et al.
2001/0047210	A1	11/2001	Wolf
2002/0116007	A1	8/2002	Lewis
2002/0156534	A1	10/2002	Grusin et al.
2003/0004573	A1	1/2003	Bagby
2003/0028253	A1	2/2003	Stone et al.
2003/0031521	A1	2/2003	Haughton et al.
2003/0114933	A1	6/2003	Bouttens et al.
2003/0125810	A1	7/2003	Sullivan et al.
2004/0049270	A1	3/2004	Gewirtz
2004/0186586	A1	9/2004	Seyer et al.
2004/0193276	A1	9/2004	Maroney et al.
2004/0193277	A1	9/2004	Long et al.
2004/0193278	A1	9/2004	Maroney et al.
2004/0220674	A1	11/2004	Pria
2004/0243136	A1	12/2004	Gupta et al.
2004/0254646	A1	12/2004	Stone et al.
2005/0107882	A1	5/2005	Stone et al.
2005/0112397	A1	5/2005	Rolfe et al.
2005/0209597	A1	9/2005	Long et al.
2005/0261775	A1	11/2005	Baum et al.
2005/0267478	A1	12/2005	Corradi et al.
2006/0004378	A1	1/2006	Raines
2006/0009852	A1	1/2006	Winslow et al.
2006/0020344	A1	1/2006	Shultz et al.
2006/0064173	A1	3/2006	Guederian
2006/0089656	A1	4/2006	Allard et al.
2006/0142866	A1	6/2006	Baratz et al.
2006/0195105	A1	8/2006	Teeny et al.
2006/0200165	A1	9/2006	Tulkis
2006/0200249	A1	9/2006	Beguín et al.
2007/0010825	A1	1/2007	Leisinger et al.
2007/0100458	A1	5/2007	Dalla Pria
2007/0123890	A1	5/2007	Way et al.
2007/0123893	A1	5/2007	O'Donoghue
2007/0123909	A1	5/2007	Rupp et al.
2007/0156246	A1	7/2007	Meswania et al.
2007/0162141	A1	7/2007	Dews et al.
2007/0173945	A1	7/2007	Wiley et al.
2007/0212179	A1	9/2007	Khangar et al.
2007/0219562	A1	9/2007	Slone et al.
2007/0225817	A1	9/2007	Reubelt et al.
2007/0233132	A1	10/2007	Valla
2008/0021564	A1	1/2008	Gunther
2008/0077146	A1	3/2008	Pernsteiner et al.
2008/0195111	A1	8/2008	Anderson
2008/0249577	A1	10/2008	Dreyfuss
2009/0171462	A1	7/2009	Poncet et al.
2009/0281630	A1	11/2009	Delince et al.
2009/0306782	A1	12/2009	Schwyzler
2010/0042214	A1	2/2010	Nebosky et al.
2010/0087927	A1	4/2010	Roche et al.
2010/0114326	A1	5/2010	Winslow et al.
2010/0191340	A1	7/2010	Dreyfuss
2010/0274360	A1	10/2010	Gunther
2010/0278601	A1	11/2010	Beynon
2011/0153023	A1	6/2011	Deffenbaugh et al.
2011/0224673	A1	9/2011	Smith
2011/0276144	A1	11/2011	Wirth et al.
2011/0313533	A1	12/2011	Gunther
2012/0022664	A1	1/2012	Vandermeulen et al.
2012/0109321	A1	5/2012	Stone et al.
2012/0184964	A1	7/2012	Hudak, Jr.
2012/0221111	A1	8/2012	Burkhead, Jr. et al.
2012/0265315	A1	10/2012	Kusogullari et al.
2012/0277880	A1	11/2012	Winslow et al.
2012/0296435	A1	11/2012	Ambacher
2013/0018476	A1	1/2013	Katrana et al.
2013/0123929	A1	5/2013	McDaniel et al.
2013/0123930	A1	5/2013	Burt
2013/0150972	A1	6/2013	Iannotti et al.
2013/0173006	A1	7/2013	Duport
2013/0178943	A1	7/2013	Duport
2013/0190882	A1	7/2013	Humphrey
2013/0211539	A1	8/2013	McDaniel et al.
2013/0261626	A1	10/2013	Chavarria et al.
2013/0261629	A1	10/2013	Anthony et al.
2013/0261754	A1	10/2013	Anthony et al.
2013/0282129	A1	10/2013	Phipps
2014/0012272	A1	1/2014	Leisinger
2014/0012380	A1	1/2014	Laurence et al.
2014/0058523	A1	2/2014	Walch et al.
2014/0074246	A1	3/2014	Huebner et al.
2014/0107792	A1	4/2014	Hopkins et al.
2014/0156012	A1	6/2014	Winslow
2014/0236304	A1	8/2014	Hodorek et al.
2014/0257499	A1	9/2014	Winslow et al.
2014/0296988	A1	10/2014	Winslow et al.
2014/0358239	A1	12/2014	Katrana et al.
2014/0358240	A1	12/2014	Katrana et al.
2014/0379089	A1	12/2014	Bachmaier
2015/0134066	A1	5/2015	Bachmaier
2015/0250601	A1	9/2015	Humphrey
2015/0289984	A1	10/2015	Budge
2015/0297354	A1	10/2015	Walch et al.
2016/0051367	A1	2/2016	Gervasi et al.
2016/0157911	A1	6/2016	Courtney, Jr. et al.
2016/0324648	A1	11/2016	Hodorek et al.
2017/0105843	A1	4/2017	Britton et al.
2017/0273800	A1	9/2017	Emerick et al.
2017/0304063	A1	10/2017	Hatzidakis et al.
2017/0367836	A1	12/2017	Cardon et al.
2019/0159906	A1	5/2019	Knox et al.
2019/0175354	A1	6/2019	Knox et al.
2019/0216518	A1	7/2019	Courtney, Jr. et al.

FOREIGN PATENT DOCUMENTS

DE	102004042502	3/2006
EP	0 274 094	8/1990
EP	1 413 265	4/2004
EP	0 959 822	5/2004
EP	1 125 565	12/2004
EP	1 518 519	3/2005
EP	1 004 283	5/2005
EP	1 639 967	3/2006
EP	1 762 191	3/2007
EP	1 952 788	8/2008
EP	1 867 303	9/2010
EP	1 977 720	1/2011
EP	1 550 420	2/2012
EP	2 261 303	11/2012
EP	1 706 074	12/2012
EP	2 564 814	3/2013
EP	2 567 676	3/2013
EP	2 574 313	4/2013
EP	2586387	A1 5/2013
EP	2 616 013	7/2013
EP	2 474 288	9/2013
EP	2 663 263	5/2014
EP	2 502 605	8/2014
EP	2 800 541	11/2014
EP	2 815 726	8/2015
EP	2 353 549	6/2016
EP	3 117 801	1/2017
EP	2 965 720	B1 7/2017
FR	2 674 122	9/1992
FR	2997290	B1 11/2015
WO	WO 01/67988	9/2001
WO	WO 02/17822	3/2002
WO	WO 2008/011078	1/2008
WO	WO 2008/146124	12/2008
WO	WO 2011/081797	7/2011
WO	WO 2012/035263	3/2012
WO	WO 2012/130524	10/2012
WO	WO 2013/009407	1/2013
WO	WO 2013/064569	5/2013
WO	WO 2013/148229	10/2013
WO	WO 2014/005644	1/2014
WO	WO 2014/058314	4/2014
WO	WO 2015/112307	7/2015
WO	2016094739	A1 6/2016

(56)

References Cited

FOREIGN PATENT DOCUMENTS

WO	WO 2017/165090	9/2017
WO	WO 2017/184792	10/2017
WO	WO 2018/022227	2/2018
WO	WO 2019/060780	3/2019

OTHER PUBLICATIONS

Non-Final Office Action issued in connection with U.S. Appl. No. 17/250,964, dated Jul. 26, 2021, 27 pages.

Final Rejection issued in connection with U.S. Appl. No. 16/249,720, dated Aug. 20, 2021, 40 pages.

Final Rejection issued in connection with U.S. Appl. No. 16/580,367, dated Aug. 24, 2021, 9 pages.

Final Rejection issued in connection with U.S. Appl. No. 17/250,964, dated Sep. 9, 2021, 22 pages.

Non-Final Office Action issued in connection with U.S. Appl. No. 16/519,937, dated Aug. 17, 2021, 21 pages.

Barth, et al., "Is global humeral head offset related to intramedullary canal width? A computer tomography morphometric study," *Journal of Experimental Orthopaedics*, 2018, vol. 5, pp. 1-8.

Boileau, et al., "The Three-Dimensional Geometry of the Proximal Humerus: Implications for Surgical Technique and Prosthetic Design," *J Bone Joint Surg*, Sep. 1997, vol. 79-B, Issue 5, pp. 857-865.

Routman, et al., "Reverse Shoulder Arthroplasty Prosthesis Design Classification System," *Bulletin of the Hospital for Joint Diseases*, 2015, vol. 73 (Suppl 1), pp. S5-S14.

Extended European Search Report for EP Appl. No. 16179642.0 dated Dec. 21, 2016 in 8 pages.

International Search Report and Written Opinion for PCT/US2014/072443 dated Mar. 24, 2015 in 12 pages.

Non-Final Office Action issued in connection with U.S. Appl. No. 16/648,128, dated Mar. 28, 2022, 43 pages.

Non-Final Office Action issued in connection with U.S. Appl. No. 17/250,964, dated Feb. 24, 2022, 12 pages.

First Office Action issued in connection with Japanese Patent Application No. 2019-555151, dated Feb. 21, 2022, 5 pages.

Office Action issued in connection with Japanese Patent Application No. 2021-518159, dated May 24, 2022, 5 pages.

Third Examination Report issued in connection with Australian Patent Application No. 2019355854, dated May 10, 2022, 4 pages.

First Examination Report issued in connection with Australian Patent Application No. 2021250994, dated Jun. 2, 2022, 5 pages.

* cited by examiner

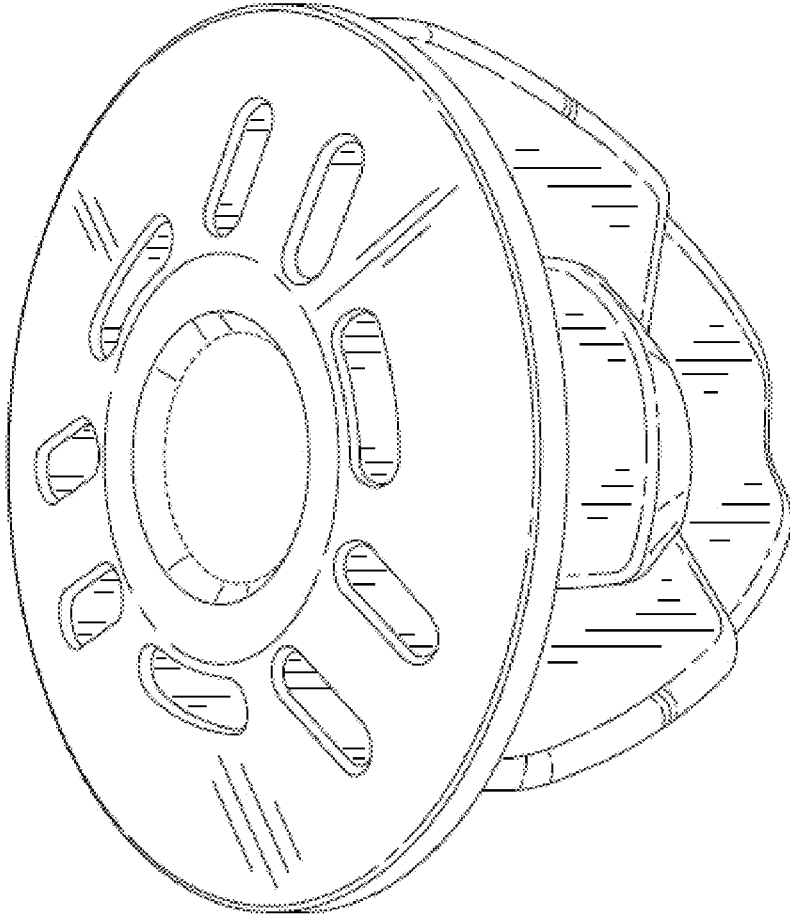

FIG. 1

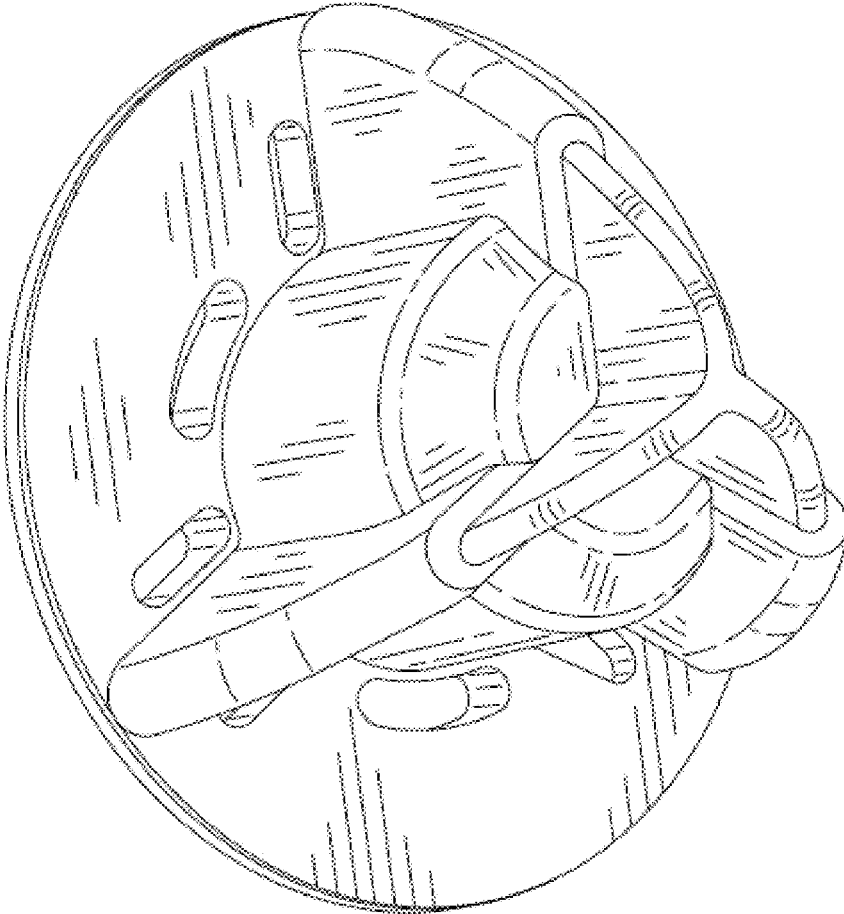

FIG. 2

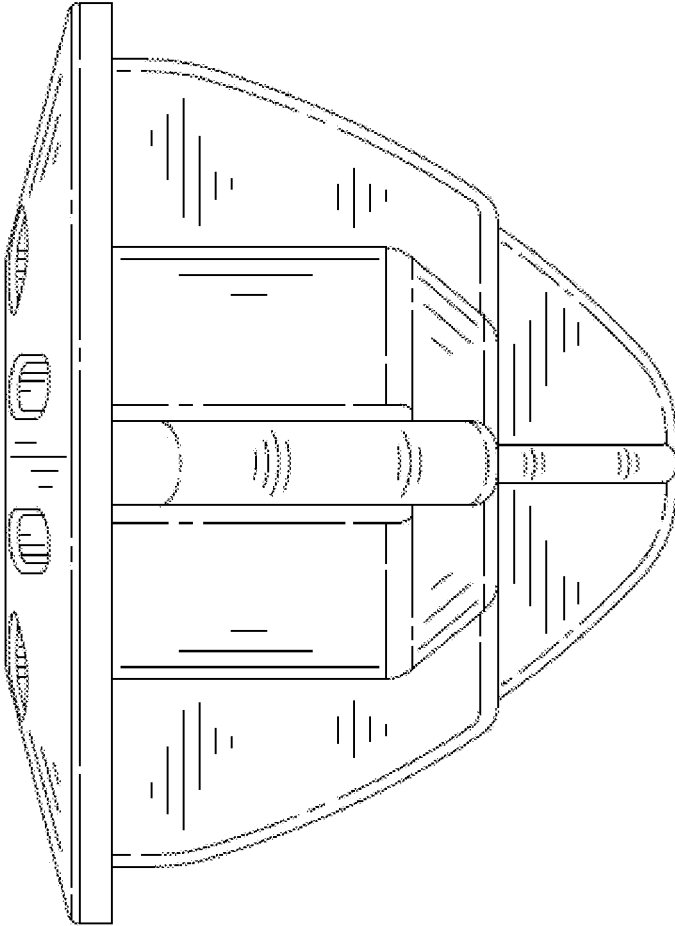

FIG. 3

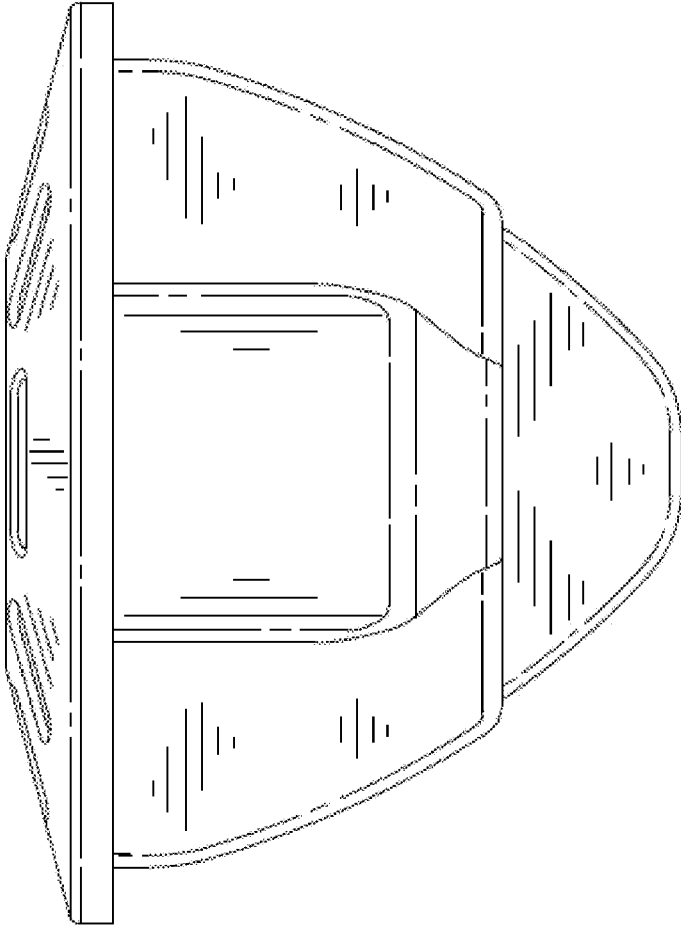

FIG. 4

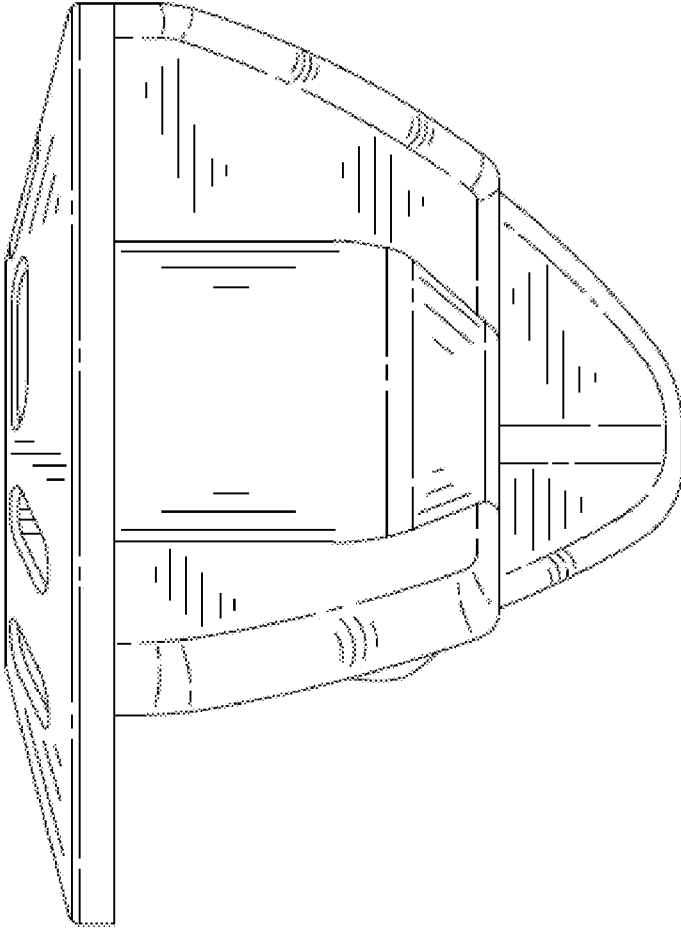

FIG. 5

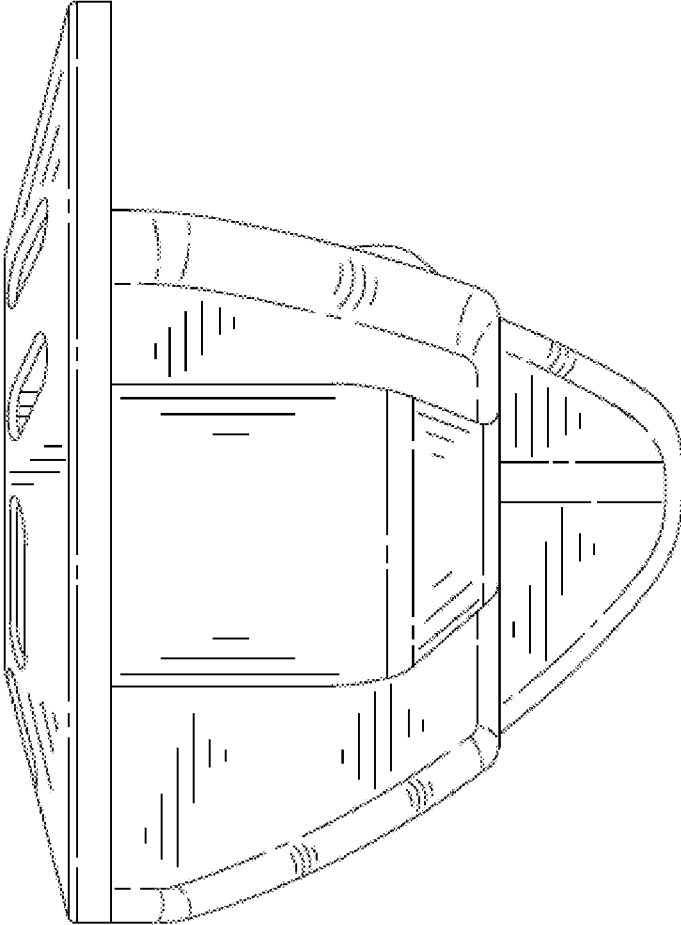

FIG. 6

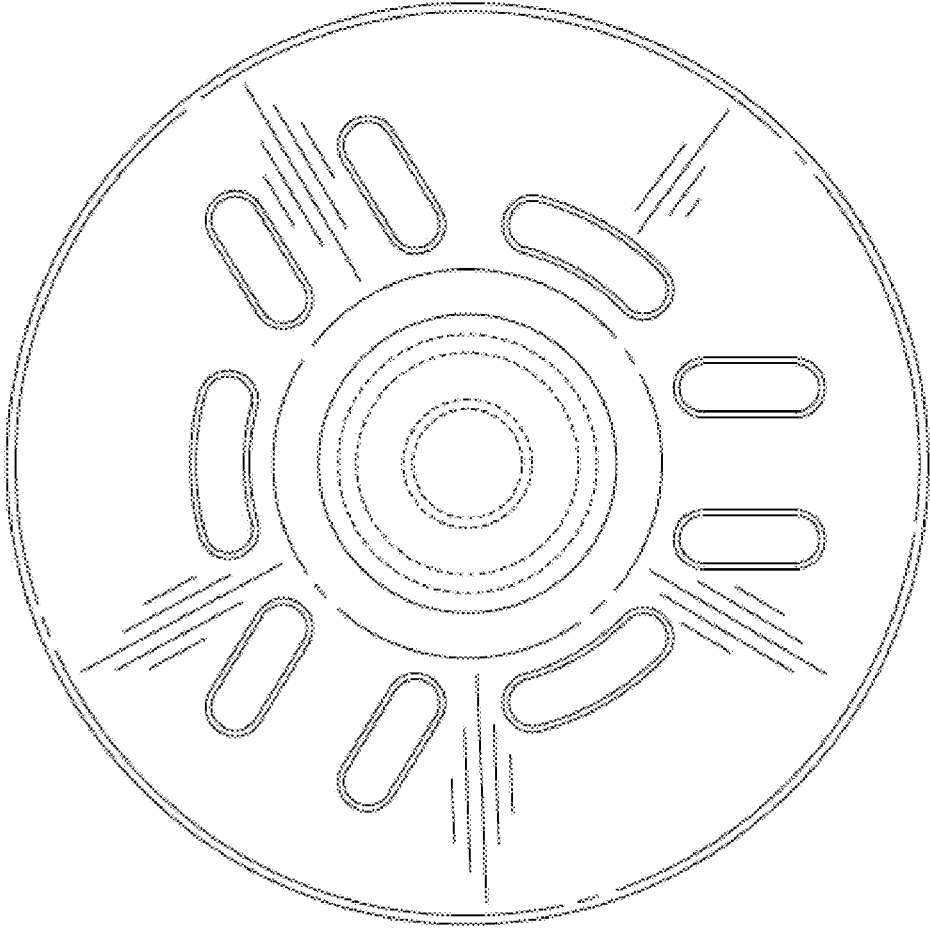

FIG. 7

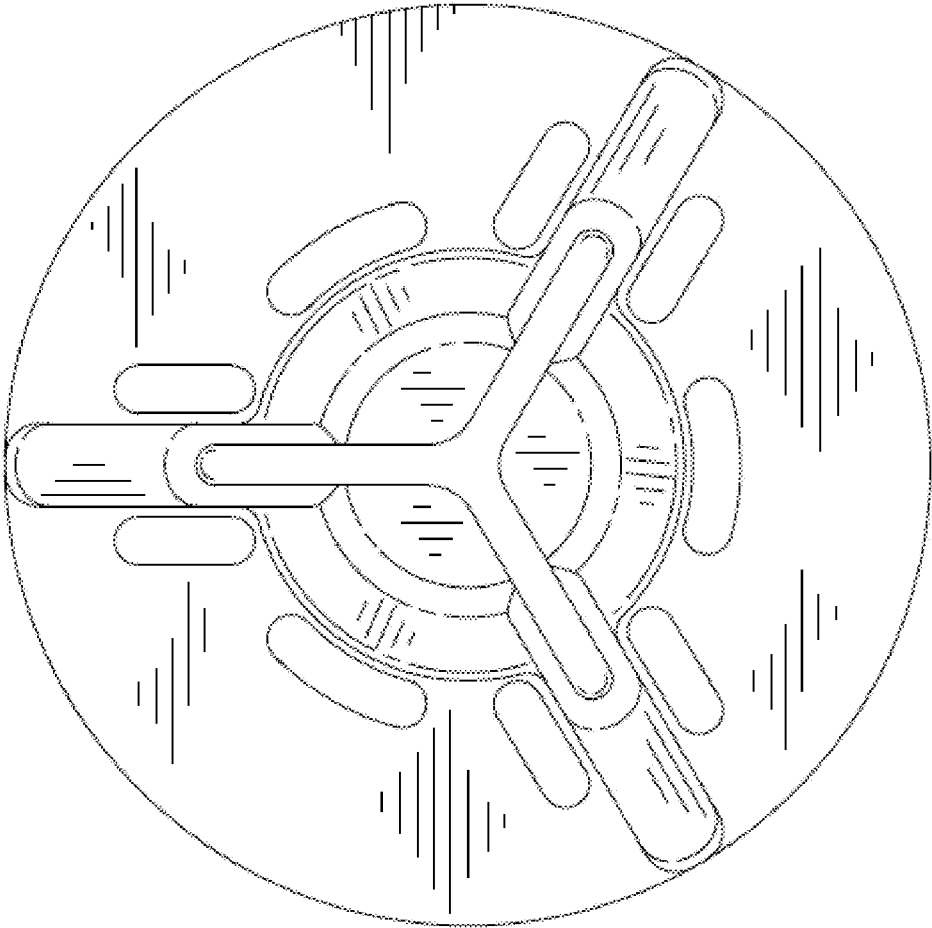

FIG. 8

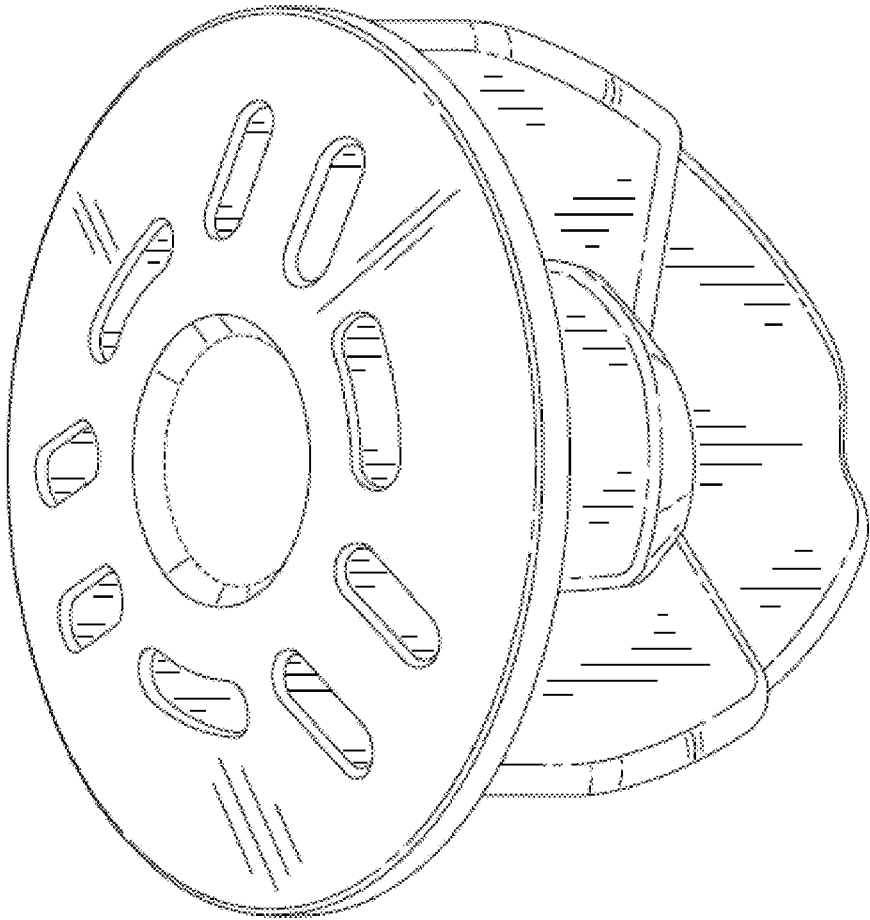

FIG. 9

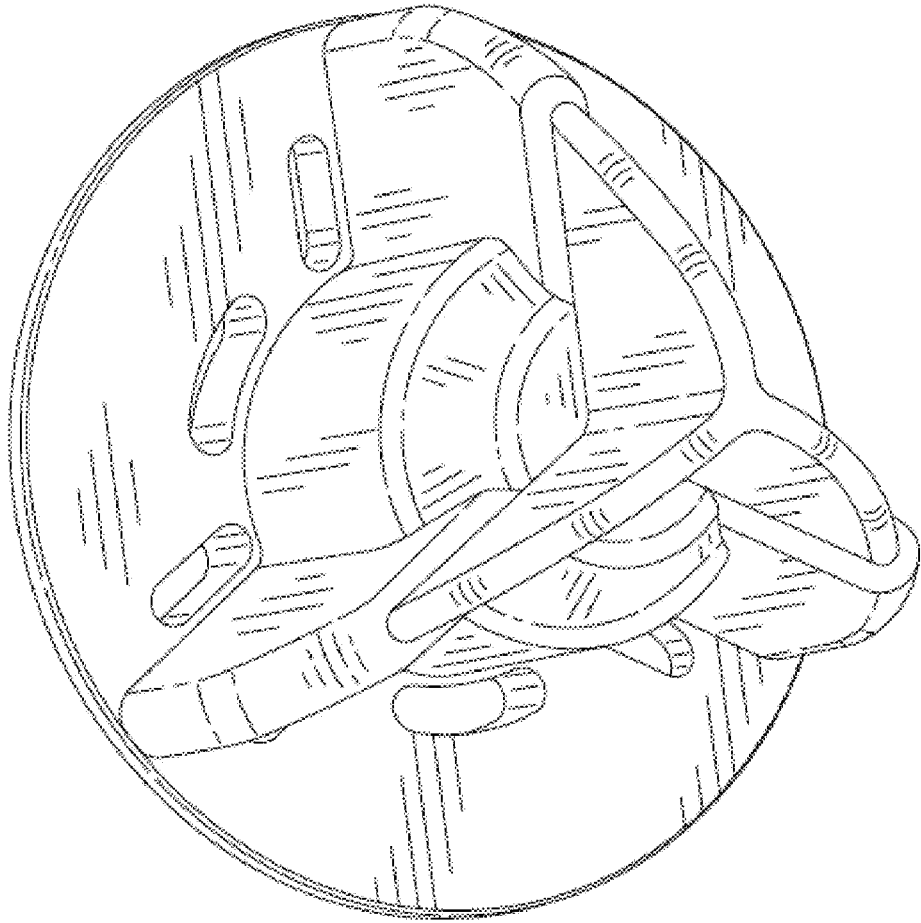

FIG. 10

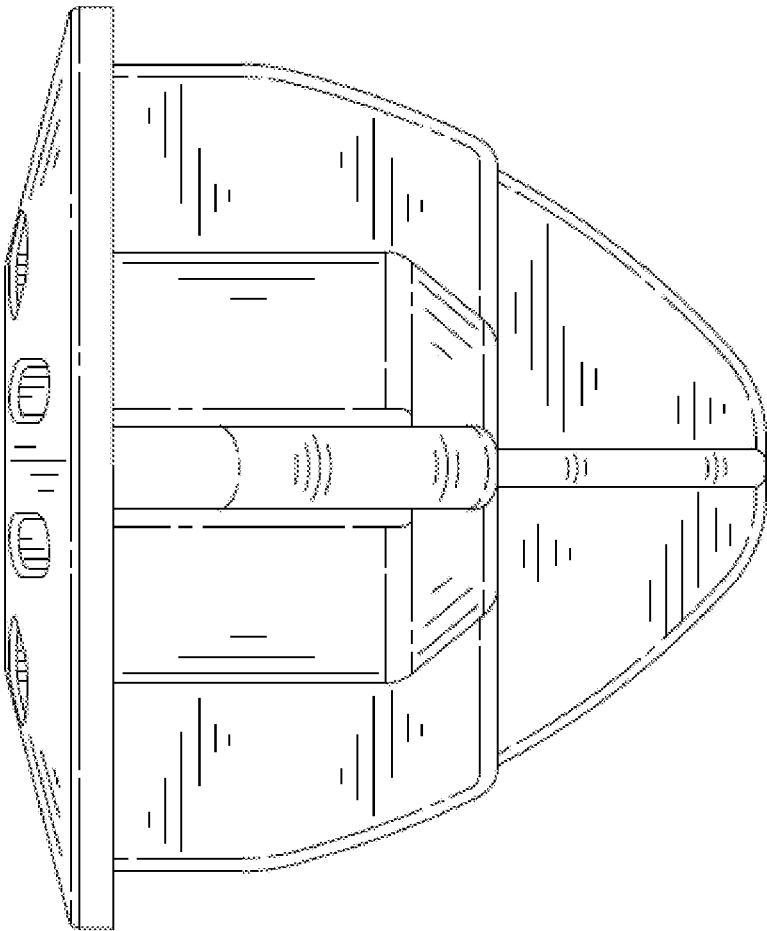

FIG. 11

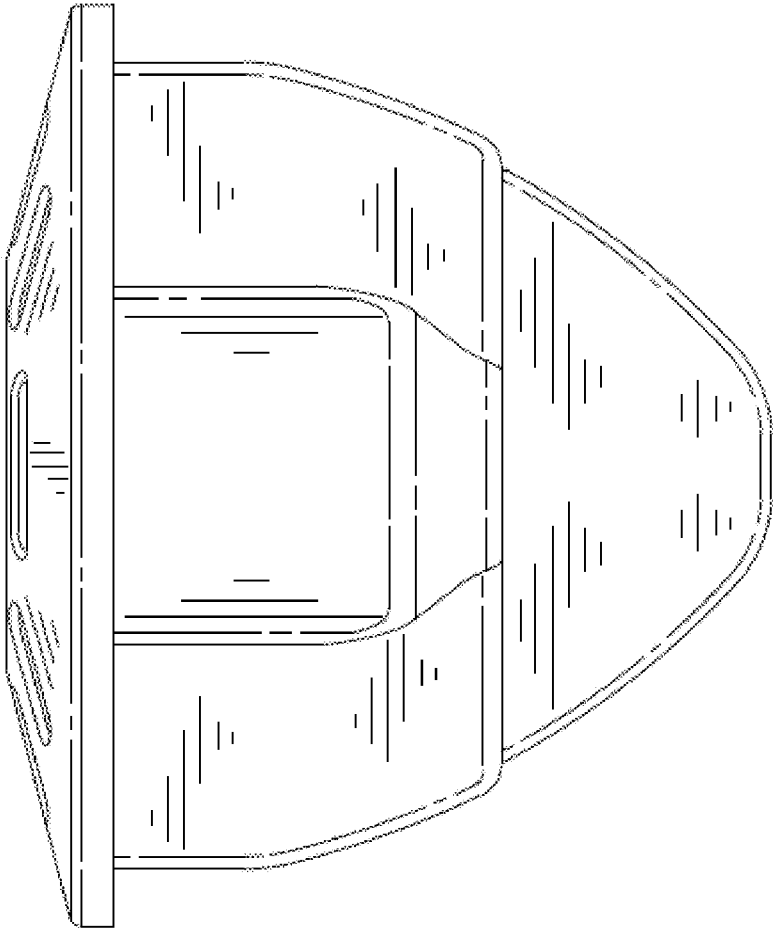

FIG. 12

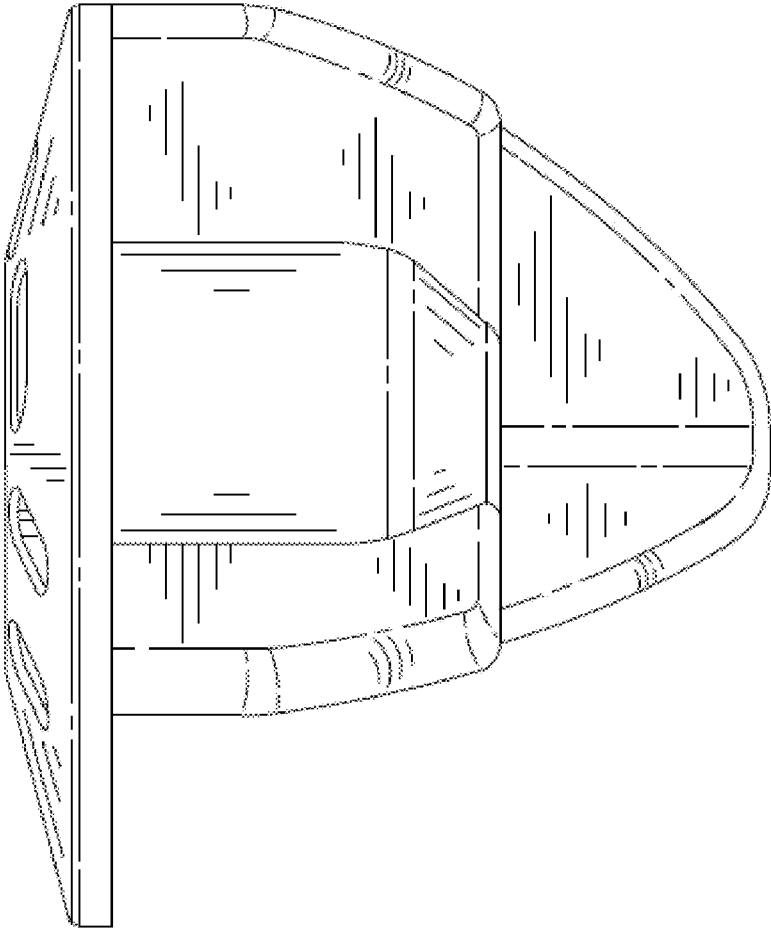

FIG. 13

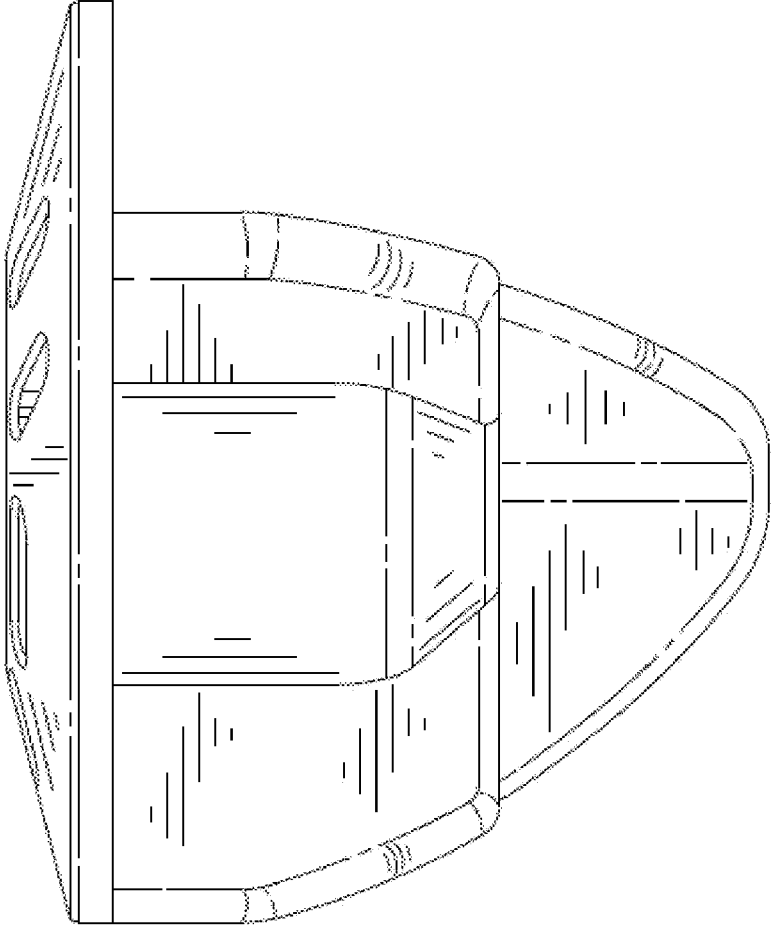

FIG. 14

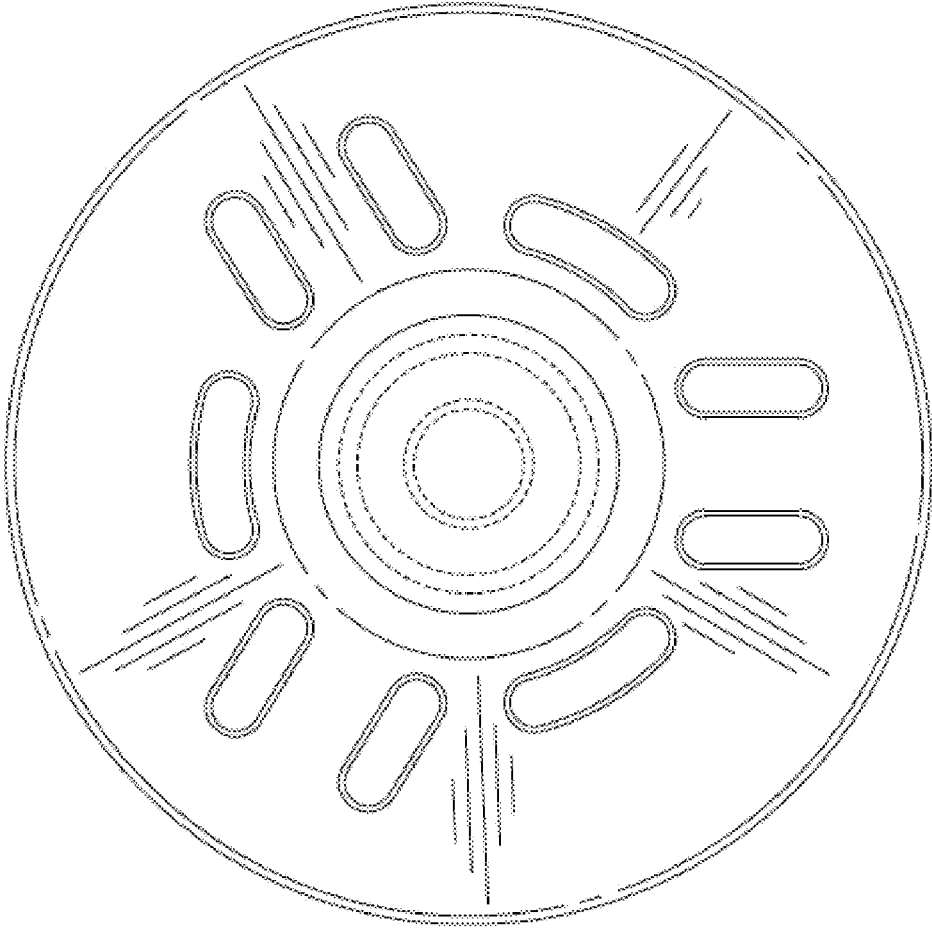

FIG. 15

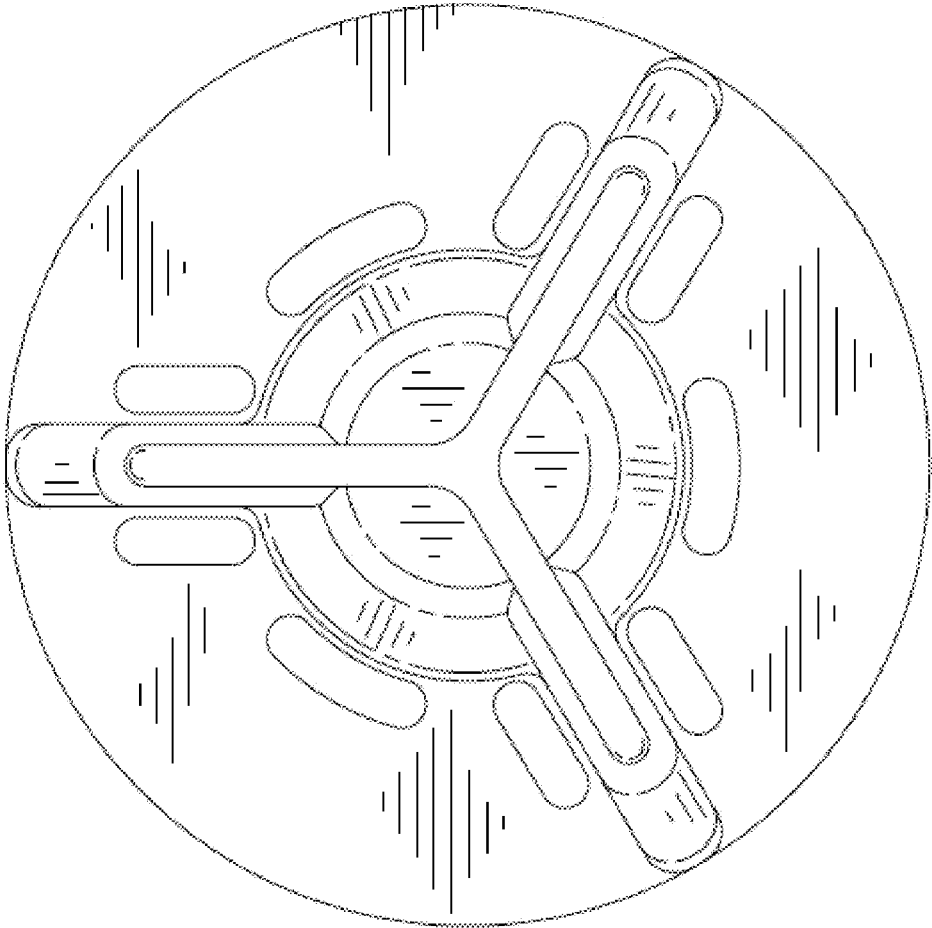

FIG. 16