



(11) **EP 1 565 621 B1**

(12) **EUROPEAN PATENT SPECIFICATION**

(45) Date of publication and mention of the grant of the patent:
30.03.2011 Bulletin 2011/13

(51) Int Cl.:
E02D 5/56 (2006.01) E02D 27/14 (2006.01)
E02B 3/06 (2006.01) A01K 63/00 (2006.01)

(21) Application number: **03809888.5**

(86) International application number:
PCT/NL2003/000744

(22) Date of filing: **30.10.2003**

(87) International publication number:
WO 2004/040069 (13.05.2004 Gazette 2004/20)

(54) **MODULAR CONSTRUCTION SYSTEM**
MODULARES KONSTRUKTIONSSYSTEM
SYSTEME DE CONSTRUCTION MODULAIRE

(84) Designated Contracting States:
AT BE BG CH CY CZ DE DK EE ES FI FR GB GR HU IE IT LI LU MC NL PT RO SE SI SK TR

(30) Priority: **30.10.2002 NL 1021783**

(43) Date of publication of application:
24.08.2005 Bulletin 2005/34

(73) Proprietor: **4D Office**
7245 PL Laren (NL)

(72) Inventor: **KRAAIJKAMP, Willem, Herman**
NL-7245 PL Laren (NL)

(74) Representative: **Winckels, Johannes Hubertus F. Vereenigde**
Johan de Wittlaan 7
2517 JR Den Haag (NL)

(56) References cited:
EP-A- 0 926 304 FR-A- 2 028 116
GB-A- 386 800 GB-A- 1 552 162
US-A- 4 405 262

EP 1 565 621 B1

Note: Within nine months of the publication of the mention of the grant of the European patent in the European Patent Bulletin, any person may give notice to the European Patent Office of opposition to that patent, in accordance with the Implementing Regulations. Notice of opposition shall not be deemed to have been filed until the opposition fee has been paid. (Art. 99(1) European Patent Convention).

Description

[0001] The invention relates to a modular construction, in particular a pond construction or other garden construction, the construction being supported in the subsoil.

[0002] For cultivating gardens, ponds are built and decorative constructions, such as pergolas and other garden furniture, are placed. The building up of such constructions is usually done by one or a few persons using relatively light material and simple tools.

[0003] For instance, pond constructions are known in which wooden piles are partly driven into the subsoil, and to which a sheet wall or board is fitted for forming a pond edge. Because the wooden piles stick in the subsoil and are supported on it, they support the sheet wall. Here, the wall is attached to the piles such that the upper edge of the wall, which is optionally designed as a girder, is approximately level. However, the wooden piles have the disadvantage that, after a limited number of years, they become subject to a rotting process. Subsidence of, for instance, pavements near the pond edge are the undesired result of this. In addition, it is difficult to change the slope of a girder supported on wooden piles when the wooden piles have already been inserted into the subsoil. This is because, due to the adhesive power of the soil, piles are difficult to pull upwards. In addition, by repositioning the pile, its stability is reduced. In order to still bring about an orientation of the girder which does not correspond with the height of the piles on which the girder is supported, one has to resort to complex auxiliary constructions.

[0004] Also, pond constructions are known in which the edge is formed by a construction with stone and concrete elements, such as for instance in patent publication JP 1998000259194. In pond constructions which incorporate stone and concrete elements, these elements form a construction basis and at least a part of the pond edge. Although the orientation of the girder can be set, it cannot be easily adjusted during construction. In concrete constructions, the concrete is poured into a formwork which cannot be adjusted afterwards without affecting the quality of the concrete. In the case of stone constructions, the orientation of the longitudinal axis of a girder can no longer be easily adjusted during construction because, then, the foundation has already been provided and the dimensions of the stones are difficult to change. In addition, building such constructions usually requires the necessary manpower. Due to the costs involved, this last is not attractive for furnishing a garden.

[0005] It is an object of the invention to provide a light, modular construction in which the orientation of a longitudinal axis of a girder with respect to the ground level is easy to adjust during construction. For this purpose, the modular construction is characterized in that it comprises at least two tubes, of which first, substantially hollow ends project into the subsoil, and where screw thread-shaped flanges are provided on the tubes, by which the tubes are supported in the subsoil, further at least two coupling

pieces which are, at least during construction, each axially freely pivotably supported on second ends of the respective tubes, and a girder attached to the coupling pieces.

5 **[0006]** By designing the supporting elements as tubes provided with a substantially hollow end, adjusting the height setting without substantially reducing the stability and bearing capacity is easier than with solid piles. This height setting determines the orientation of a longitudinal
10 axis of the girder in that it is supported on the heads of the tubes via the coupling pieces. In addition, the hollow end of the tubes has the advantage that, compared to a solid pile, less force is required for the constructor to insert the tube into the ground.

15 **[0007]** By providing the tubes with screw thread-shaped flanges, by which the tubes are supported in the subsoil, in an absolute sense, the tubes are well settable relative to one another, namely by rotating the tubes.

20 **[0008]** Because, during construction, the coupling pieces are axially freely pivotably supported on second ends of the tubes, the constructor can easily set the axial orientation of the coupling piece without affecting the height of the tubes. Since the axial orientation of the coupling piece is independent of the axial position of the tube,
25 the height of the tube is also settable without changing the axial position of the coupling piece. This makes it relatively easy, also during construction, when the girder is already supported on the tubes, to adjust the vertical position of the girder.

30 **[0009]** Owing to the above-described tubes with a partly hollow design and axially freely pivotable coupling pieces supporting the girder, the modular construction offers so much flexibility that the relatively light system can even be built up by one person. Here, it is not necessary to set
35 everything definitively at once. As described, the system provides the very possibility to change height settings during its construction.

40 **[0010]** It is noted that patent publication US 4 405 262 discloses a pile construction for constructing relatively large hydraulic engineering works. The piles are with a closed, downwardly oriented end driven into the subsoil. Further, a coupling means rests on a layer of sand which is provided on a partition plate in the pile.

45 **[0011]** In an embodiment according to the invention which can particularly be used in a pond construction, a foil is clamped between the girder and a clamping section clamping around the girder. In this manner, the foil that covers a basin of the pond is secured to the girder.

50 **[0012]** In another embodiment according to the invention, the modular construction is a pier construction in a pond.

[0013] In another embodiment according to the invention, the modular construction is a pergola construction.

55 **[0014]** The invention also relates to a modular construction system for use in above-described constructions.

[0015] In a preferred embodiment according to the invention, the tubes, the coupling pieces and the girder are

substantially made of steel and/or plastic. This yields a construction which is both light and durable.

[0016] By providing the hollow tubes, near the heads, with an engaging element for cooperation with a driving element for exerting a turning moment on the tubes, the rotating of the tubes is facilitated when the tubes project into the ground. Especially when setting the height of the individual tubes, this yields a considerable advantage over rotating the tubes by clutching these by hand. The engaging element is positioned near the head, but preferably removed from the head such that the engaging element is still accessible after positioning the coupling pieces, so that the height of the tubes is still easy to set, also including coupling piece and optionally the mounted girder.

[0017] Preferably, cutting sections are formed to the substantially hollow ends of the tubes, so that the tube encounters less resistance when being inserted into the subsoil.

[0018] The invention further relates to a method for building up a modular construction, in particular for use with ponds and other garden constructions, comprising the steps of rotating at least two ends with a substantially hollow design provided on at least two respective tubes into the subsoil, while the screw thread-shaped flanges provided on the outside of the tubes contact the subsoil, sliding coupling pieces which are axially freely pivotable during construction on respective heads provided at another end of the respective tubes, setting the height of the tubes by axially rotating them, setting the axial orientation of the respective coupling pieces by pivoting them relative to the respective tubes, and attaching a girder to the coupling pieces.

[0019] In a preferred embodiment of the method according to the invention, the method is used for building a pond construction, characterized in that, after the steps mentioned, also, the steps are carried out of digging a pond basin; laying a foil in the pond basin; and attaching the foil to the girder.

[0020] By using the modular construction system in combination with a foil which covers the basin of the pond, only the basin needs to be dug out. In this manner, it is achieved that, in contrast to, for instance, pond constructions with wooden piles, where the space for a sheet piling is also dug out, the soil structure around the pond edge remains intact.

[0021] Further advantageous embodiments of the invention are described in the dependent claims.

[0022] The invention will be further elucidated with reference to an exemplary embodiment shown in the Figures, in which:

Fig. 1 shows a diagrammatic view of a modular construction according to the invention;

Fig. 2 shows a diagrammatic perspective view of a hollow tube according to the invention;

Fig. 3 shows a diagrammatic perspective view of a coupling piece according to the invention;

Fig. 4 shows a diagrammatic perspective view of a different coupling piece according to the invention; Fig. 5 shows a diagrammatic perspective view of a modular construction system according to the invention with a section girder;

Fig. 6 shows a perspective side elevational view of a modular construction system according to the invention with a girder designed as a flexible tube;

Fig. 7 shows a diagrammatic side elevational view of a clamping section according to the invention provided with a flange edge.

Fig. 8 shows a diagrammatic side elevational view of the clamping section of Fig. 7, with the flange edge being obliquely bent with respect to the ground level; Fig. 9 shows a modular construction system according to the invention to which a sheet element is attached;

Fig. 10 shows a pond with a pier; and

Fig. 11 shows a modular construction system according to the invention.

[0023] The Figures are just diagrammatic representations of a preferred embodiment of the invention. In the Figures, same parts are designated by the same reference numerals.

[0024] Fig. 1 shows a modular construction 1, in which tubes 2 are supported in the subsoil 4. On the tubes 2, coupling pieces 5 are supported which, in their turn, support a girder 7.

[0025] Fig. 2 shows a hollow tube 2 which is provided with a head 6 at one end and ends in a point 12 at the other end. On the outside of the hollow tube 2, screw thread-shaped flanges 3 have been provided. The hollow tube 2 is preferably designed in metal or plastic. The hollow tube 2 is inserted into the subsoil by exerting a downward force on the tube 2, which is directed downwards by the point 12. As soon as the screw thread-shaped flanges 3 have contacted the subsoil 4, the downward force can be combined with a forced axial moment, so that the flanges 3 drive the hollow tube 2 into the subsoil 4. Here, the downward force can even be taken away completely. To facilitate the exertion of the axial moment, near the head 6, the tube 2 is provided with an engaging element, such as two oppositely provided openings, or a projection or recess. Through the openings, a pin can be slid which transmits a moment of force or a torque to the tube. With projections or recesses, the moment is exerted using, for instance, an open-end wrench or a socket head wrench. In a heavier embodiment, the engaging element is blockingly connectable to an electric drive. In this manner, by means of the screw thread-shaped flanges 3, a relatively heavy tube 2 can relatively easily be inserted into the subsoil 4 by one person.

[0026] Figs. 3 and 4 show two embodiments of an axially freely pivotable coupling piece 5 comprising a tube 22 and a supporting section 23 attached on it. The diameter of the tube can be designed as a circle, but, for instance, also as a square. In Fig. 3, the supporting section

23 is shaped as a straight section. Other shapes are also possible. For instance, in Fig. 4, the supporting section is shaped as a section with an acute angle of approximately 90°.

[0027] In a different embodiment, the coupling piece 5 comprises a tube 22 provided with a supporting means for being supported on the head of the hollow tube 2, such as a flange on the outside wall or a closing surface on the inside of the tube 22. At one end, the tube 22 is provided with recesses, such as slots for supporting a girder 7, which can be horizontally slid through the recesses of the tube 22 during assembly.

[0028] Figs. 5 and 6 show a modular construction system 1 in which a hollow tube 2 has been inserted into the subsoil. Over the head 6 of the hollow tube 2, the tube 22 of a coupling piece 5 has been slid. Another possibility to mount the coupling piece 5 is, for instance, sliding the tube 22 into the hollow tube 2. In both situations, the coupling piece 5 is supported on the head 6 of the hollow tube 2 for supporting a thin-walled girder 7 attached on the supporting section 23. This girder 7 can be designed as an open section (Fig. 5), such as a U or I-section, or as a flexible tube (Fig. 6). Other possibilities are, for instance, a plate or a closed section, such as a box girder. The girder can be built up from girder segments which can be intercoupled by attachment means, for instance regularly spaced apart holes at the ends of the girder. Over the girder 7, which is optionally provided with a rubber protection section at the upper edge, lies a foil 11 which is clamped on the girder 7 by means of a clamping section 10 to obtain a durable clamping construction. The foil serves as a pond floor in the basin 18 of a pond 24. For constructing a pond 24 with a pond edge 20 of any shape, a plate or a flexible tube is preferred as a girder 7 because of the possibility to bring it into the desired shape on site. The flexible tube can be internally strengthened by a section, such as for instance a vertical strip clamped in the tube. Owing to the bend of the tube, the strip stays in vertical position, so that it does not necessarily need to be fixed.

[0029] While building up the modular construction 1, the constructor proceeds as follows. First of all, at least two hollow tubes 2 are inserted into the subsoil 4 as described hereinabove. Then, on each hollow tube 2, a coupling piece 5 is slid, an axial orientation being set. Attachment means 12, such as for instance a clamping screw, serve to attach the girder 7 to the coupling pieces 5. After that, for adjusting the orientation of a longitudinal axis of a girder 7 with respect to the ground level, the definitive height of the supporting hollow tubes 2 can be set by axially rotating them. This is possible despite the attached girder 7 because the coupling pieces 5 are axially pivotable. After the definitive setting, the coupling pieces 5 are locked using locking means 13. These locking means comprise, for instance, a bolt and a nut. It is also possible to provide the tube 22 of the coupling pieces 5 with eccentrically provided holes with a screw thread for locking by means of a clamping bolt.

[0030] The modular construction system 1 can further serve as a basis for, for instance, clamping a foil 11 for a pond basin 18, as shown in Fig. 10, or for supporting a pavement 27. Because the foil 11 *inter alia* serves as pond edge 20, only the pond basin 18 needs to be dug out, and not the location where the pond edge is anchored to the subsoil, as is the case with, for instance, wooden sheet pilings. In this manner, the soil structure at the pond edge 20 remains intact.

[0031] In a variant according to the invention, the clamping section 10 for clamping the foil 11 is provided with a flange 15 at the pond side of the construction. As Fig. 7 shows, the flange 15 can be provided on the side wall of the clamping section 10, for instance below the level of the upper edge of the section 10 and the level of the subsoil for the pavement 27. The flange 15 serves to support a row of stones 17, whose top surface is optionally lower than the top side of the pavement 27. As Fig. 8 shows, the flange edge can also be bent obliquely upwards with respect to the ground level, so that the ground level 28 maximally continues to above the water level 14 in the pond 24.

[0032] As Fig. 9 shows, further, the hollow tubes 2, for the embellishment and protection of the pond construction 24, can be provided with attachment means 9, for instance regularly spaced apart, for attaching sheet elements 8, such as a plate section or a natural stone, or retaining walls (not shown). The sheet elements 8 can not only be provided at the side of the pond, but also at the side of, or above the ground level. The construction can serve to stabilize all sorts of height differences. In the case of retaining walls, section side boards of all sorts of materials are vertically positioned and optionally mutually strengthened by means of auxiliary sections. Also, side boards can be intercoupled using auxiliary sections.

[0033] On girders 7, other girders can be positioned by means of a supporting section comprising two U-sections attached to each other by their respective sides without ends (the lying sides), so that the two U-sections can both clamp a girder. The mutual orientation of the U-sections, for instance transversely, determines the orientation of the thus attached girders.

[0034] The invention is not limited to the exemplary embodiment described herein. Many variants are possible. For instance, the modular construction system 1 can also serve as a basis for, for instance, a pier construction 19, as shown in Fig. 10, or for a pergola construction 21, or other garden furniture construction, as shown in Fig. 11.

[0035] Such variants will be clear to a person skilled in the art and are understood to be within the scope of the invention as set forth in the following claims.

55 Claims

1. A light modular construction (1), in particular a pond construction or other garden construction, wherein

- the constructions (1) is supported in the subsoil (4), comprising
- at least two tubes (2), of which first, substantially hollow ends (12) project into the subsoil (4), and wherein screw thread-shaped flanges (3) are provided on the tubes (2), which support the tubes (2) in the subsoil (4) and which enable a height adjustment of the tubes (2) by axially rotating them,
 - at least two coupling pieces (5) which are, at least during construction, each axially freely pivotably supported on a second end (6) of the respective tubes (2), and
 - a girder (7) attached to the coupling pieces (5).
2. A modular construction (1) according to claim 1, **characterized in that**, near the heads (6), the tubes (2) are provided with an engaging element (29) for cooperation with a driving element for exerting a turning moment on the tubes (2).
3. A modular construction (1) according to claim 1 or 2, **characterized by** a foil (11) and a clamping section (10), by means of which the foil (11) is clamped on the girder (7).
4. A modular construction (1) according to any one of claims 1-3, **characterized in that** the construction is a pier construction.
5. A modular construction (1) according to claim 1, **characterized in that** the construction is a pergola construction (21).
6. A modular construction system for use in constructions according to claim 1, comprising
- at least two tubes (2), each having a first, substantially hollow end (12), wherein screw thread-shaped flanges (3) are provided on the tubes (2),
 - at least two coupling pieces (5) which fit on second ends (6) of the tubes (2), for being axially freely pivotably supported on the second ends (6) during construction, and
 - a girder (7) for attaching to the coupling pieces (5).
7. A modular construction system according to claim 6, **characterized in that** the tubes (2), the coupling pieces (6) and the girder (7) are substantially made of steel and/or plastic.
8. A modular construction system according to claim 6 or 7, **characterized in that**, near the heads (6), the tubes (2) are provided with an engaging element (29) for cooperation with a driving element for exerting a turning moment on the tubes (2).
9. A modular construction system according to any one of claims 6-8, **characterized in that** cutting sections have been formed on the substantially hollow ends (12) of the tubes (2).
10. A modular construction system according to any one of claims 6-9, **characterized in that** the construction system is provided with a clamping section (10) for clamping a foil (11) between the girder (7) and the clamping section (10).
11. A modular construction system according to claim 10, **characterized in that** the girder (7) or the clamping section (10) is provided with a flange (15) for supporting a pond edge.
12. A modular construction system according to claim 11, **characterized in that** the girder (7) or the clamping section (10) is provided with side parts for contacting the coupling piece (5), wherein the flange (15) is bent obliquely, away from the side parts, so that the flange (15) allows the ground level to continue to above the water level (14) of a pond (24).
13. A modular construction system according to any one of claims 6-12, **characterized in that** the tubes (2) are provided with attachment means for attaching sheet elements and/or retaining walls.
14. A modular construction system according to any one of claims 6-13, **characterized in that** the girder (7) is designed as a plate or tube.
15. A method for building up a light modular construction (1), in particular pond constructions or other garden constructions, comprising the steps of
- rotating at least two tubes (2) into the subsoil (4), which are each provided with a substantially hollow end (12) on the side rotated into the subsoil (4), and wherein screw thread-shaped flanges (3) have been provided on the tubes (2) for supporting in the subsoil (4),
 - setting the height of the tubes (2) by axially rotating them,
 - sliding coupling pieces (5) on second ends (6) provided on each of the tubes (2), wherein, during construction, the coupling pieces (5) are axially freely pivotably supported on the second ends (6),
 - setting the axial orientation of the coupling pieces (5) by pivoting them relative to the respective tubes (2), and
 - attaching a girder (7) to the coupling pieces (5).
16. A method for building up a modular construction according to claim 15, **characterized in that** the method further comprises the step of locking the coupling

pieces (5) in an axial direction with respect to the tubes (2) after setting the height of the tubes (2) and setting the axial orientation of the coupling pieces (6).

17. A method for building a pond construction according to the method of claim 15 or 16, **characterized in that**, after the said steps, further, the steps are carried out of

- digging a pond basin,
- laying a foil in the pond basin, and
- attaching the foil (11) to the girder (7).

Patentansprüche

1. Leichtgewichtige Modulkonstruktion (1), insbesondere eine Teich-Konstruktion oder eine andere Gartenkonstruktion, wobei die Konstruktion (1) im Unterboden (4) gestützt ist, mit

- mindestens zwei Rohren (2), von denen erste, im Wesentlichen hohle Enden (12) in den Unterboden (4) ragen, und wobei an den Rohren (2) schraubenförmige Flansche (3) vorgesehen sind, welche die Rohre (2) in dem Unterboden (4) stützen und, indem sie axial gedreht werden, eine Höheneinstellung der Rohre (2) ermöglichen,
- mindestens zwei Kopplungsstücken (5), die mindestens während der Konstruktion jeweils axial frei schwenkbar an dem zweiten Ende (6) der jeweiligen Rohre (2) gelagert sind, und
- einem Träger (7), der an den Kopplungsstücken (5) befestigt ist.

2. Modulkonstruktion (1) nach Anspruch 1, **dadurch gekennzeichnet, dass** nahe den Kopfteilen (6) die Rohre (2) mit einem Eingriffselement (29) zum Zusammenwirken mit einem Antriebselement versehen sind, um ein Drehmoment auf die Rohre (2) auszuüben.

3. Modulkonstruktion (1) nach Anspruch 1 oder 2, **gekennzeichnet durch** einen Film (11) und einen Klemmabschnitt (10), mittels dessen der Film (11) an dem Träger (7) festgeklemmt wird.

4. Modulkonstruktion (1) nach einem der Ansprüche 1-3, **dadurch gekennzeichnet, dass** die Konstruktion eine Pier-Konstruktion ist.

5. Modulkonstruktion (1) nach Anspruch 1, **dadurch gekennzeichnet, dass** die Konstruktion eine Lauben-Konstruktion (21) ist.

6. Modulkonstruktionssystem zur Verwendung bei Konstruktionen gemäß Anspruch 1, mit

- mindestens zwei Rohren (2), die jeweils ein erstes, im Wesentlichen hohles Ende (12) aufweisen, wobei an den Rohren (2) schraubengewindeförmige Flansche (3) vorgesehen sind,
- mindestens zwei Kopplungsstücken (5), die an den zweiten Enden (6) der Rohre (2) derart passend befestigbar sind, dass sie während der Konstruktion axial frei schwenkbar an den zweiten Enden (6) gelagert sind, und
- einem Träger (7) zur Befestigung an den Kopplungsstücken (5).

7. Modulkonstruktionssystem nach Anspruch 6, **dadurch gekennzeichnet, dass** die Rohre (2), die Kopplungsstücke (5) und der Träger (7) im Wesentlichen aus Stahl und/oder Plastik ausgebildet sind.

8. Modulkonstruktionssystem nach Anspruch 6 oder 7, **dadurch gekennzeichnet, dass** nahe den Kopfteilen (6) die Rohre (2) mit einem Eingriffselement (29) zum Zusammenwirken mit einem Antriebselement versehen sind, um ein Drehmoment auf die Rohre (2) auszuüben.

9. Modulkonstruktionssystem nach einem der Ansprüche 6-8, **dadurch gekennzeichnet, dass** an den im Wesentlichen hohlen Enden (12) der Rohre (2) Schneidabschnitte ausgebildet sind.

10. Modulkonstruktionssystem nach einem der Ansprüche 6-9, **dadurch gekennzeichnet, dass** das Konstruktionssystem mit einem Klemmabschnitt (10) versehen ist, um einen Film (11) zwischen dem Träger (7) und dem Klemmabschnitt (10) festzuklemmen.

11. Modulkonstruktionssystem nach Anspruch 10, **dadurch gekennzeichnet, dass** der Träger (7) oder der Klemmabschnitt (10) mit einem Flansch (15) zum Halten einer Teich-Einfassung versehen ist.

12. Modulkonstruktionssystem nach Anspruch 11, **dadurch gekennzeichnet, dass** der Träger (7) oder der Klemmabschnitt (10) mit Seitenteilen zum Kontaktieren des Kopplungsstücks (5) versehen ist, wobei der Flansch (15) schräg von den Seitenteilen weg gebogen ist, so dass der Flansch (15) eine Fortführung des Bodenniveaus bis über das Wasserniveau (14) eines Teichs (24) ermöglicht.

13. Modulkonstruktionssystem nach einem der Ansprüche 6-12, **dadurch gekennzeichnet, dass** die Rohre (2) mit Befestigungsvorrichtungen zum Befestigen von Bahnelementen und/oder Haltewänden versehen sind.

14. Modulkonstruktionssystem nach einem der Ansprüche 6-13, **dadurch gekennzeichnet, dass** der

Träger (7) als Platte oder Rohr ausgebildet ist.

15. Verfahren zum Aufbau einer leichtgewichtigen Modulkonstruktion (1), insbesondere einer Teich-Konstruktion oder einer anderen Gartenkonstruktion, mit folgenden Schritten:

- Drehen mindestens zweier Rohre (2) in den Unterboden (4), wobei die Rohre jeweils an der in den Unterboden (4) gedrehten Seite ein im Wesentlichen hohles Ende (12) aufweisen, und wobei an den Rohren (2) schraubenförmige Flansche (3) zur Stützung in dem Unterboden (4) vorgesehen sind,
- Einstellen der Höhe der Rohre (2), indem diese axial gedreht werden,
- Aufschieben von Kopplungsstücken (5) auf zweite Enden (6), welche jedes der Rohre (2) aufweist, wobei während der Konstruktion die Kopplungsstücke (5) axial frei schwenkbar an den zweiten Enden (6) gelagert sind,
- Einstellen der axialen Ausrichtung der Kopplungsstücke (5) durch Schwenken der Kopplungsstücke relativ zu den jeweiligen Rohren (2), und
- Befestigen eines Trägers (7), der an den Kopplungsstücken (5).

16. Verfahren zum Aufbau einer Modulkonstruktion gemäß Anspruch 15, **dadurch gekennzeichnet, dass** das Verfahren ferner den Schritt des in einer Axialrichtung erfolgenden Verriegelns der Kopplungsstücke (5) relativ zu den Rohren (2) umfasst, nachdem die Höhe der Rohre (2) eingestellt worden ist und die axiale Ausrichtung der Kopplungsstücke (5) eingestellt worden ist.

17. Verfahren zum Aufbau einer Teich-Konstruktion entsprechend dem Verfahren gemäß Anspruch 15 oder 16, **dadurch gekennzeichnet, dass** nach den besagten Schritten ferner folgende Schritte ausgeführt werden:

- Graben eines Teich-Bassins,
- Legen eines Films in das Teich-Bassin,
- Befestigen des Films (11) an dem Träger (7).

Revendications

1. Construction modulaire légère (1), en particulier construction de bassin ou autre construction de jardin, dans laquelle la construction (1) est portée dans le sous-sol (4), comprenant

- au moins deux tubes (2) dans lesquels des premières extrémités (12), sensiblement creuses, se projettent en pénétrant dans le sous-sol

(4), et dans laquelle des brides en forme de pas de vis (3) sont prévues sur les tubes (2), qui supportent les tubes (2) dans le sous-sol (4) et qui permettent un ajustement de hauteur des tubes (2) en les faisant tourner axialement,

- au moins deux pièces d'accouplement (5) qui sont, au moins pendant la construction, chacune libre de pivoter axialement et supportées sur une seconde extrémité (6) des tubes respectifs (2), et
- une poutre (7) attachée aux pièces d'accouplement (5).

2. Construction modulaire (1) selon la revendication 1, **caractérisée en ce que**, à proximité des têtes (6), les tubes (2) sont dotés d'un élément d'engagement (29) pour coopération avec un élément d'entraînement afin d'exercer un moment tournant sur les tubes (2).

3. Construction modulaire (1) selon la revendication 1 ou 2, **caractérisée par** une feuille (11) et par une section de pincement (10) au moyen de laquelle la feuille (11) est pincée sur la poutre (7).

4. Construction modulaire (1) selon l'une quelconque des revendications 1 à 3, **caractérisée en ce que** la construction est une construction formant quai.

5. Construction modulaire (1) selon la revendication 1, **caractérisée en ce que** la construction est une construction formant pergola (21).

6. Système de construction modulaire destiné à être utilisé dans des constructions selon la revendication 1, comprenant

- au moins deux tubes (2), ayant chacun une première extrémité creusé (12), tels que des brides en forme de pas de vis (3) sont prévues sur les tubes (2),
- au moins deux pièces d'accouplement (5), qui sont montées sur des secondes extrémités (6) des tubes (2) pour être supportées libres de pivoter axialement sur les secondes extrémités (6) pendant la constructions, et
- une poutre (7) destinée à être attachée sur les pièces d'accouplement (5).

7. Système de construction modulaire selon la revendication 6, **caractérisé en ce que** les tubes (2), les pièces d'accouplement (5) et la poutre (7) sont sensiblement réalisés en acier et/ou en matière plastique.

8. Système de construction modulaire selon la revendication 6 ou 7, **caractérisé en ce que**, à proximité des têtes (6), les tubes (2) sont dotés d'un élément

- d'engagement (29) destiné à coopérer avec un élément d'entraînement pour exercer un moment tournant sur les tubes (2),
9. Système de construction modulaire selon l'une quelconque des revendications 6 à 8, **caractérisé en ce que** des sections découpées ont été formées sur les extrémités sensiblement creuses (12) des tubes (2). 5
10. Système de construction modulaire selon l'une quelconque des revendications 6 à 9, **caractérisé en ce que** le système de construction est doté d'une section de pincement (10) pour pincer une feuille (11) entre la poutre (7) et la section de pincement (10). 10
11. Système de construction modulaire selon la revendication 10, **caractérisé en ce que** la poutre (7) ou la section de pincement (10) est pourvue d'une bride (15) pour supporter une bordure d'un bassin. 15
12. Système de construction modulaire selon la revendication 11, **caractérisé en ce que** la poutre (7) ou la section de pincement (10) est dotée de parties latérales pour venir en contact avec la pièce d'accouplement (5), ladite bride (15) étant cintrée en oblique, en éloignement des parties latérales, de sorte que la bride (15) permet au niveau du sol de continuer jusqu'au-dessus du niveau de l'eau (14) dans un bassin (24). 20
13. Système de construction modulaire selon l'une quelconque des revendications 6 à 12, **caractérisé en ce que** les tubes (2) sont dotés de moyens d'attache pour attacher des éléments en feuille et/ou pour retenir des parois. 25
14. Système de construction modulaire selon l'une quelconque des revendications 6 à 13, **caractérisé en ce que** la poutre (7) est conçue comme une plaque ou un tube. 30
15. Procédé pour ériger une construction modulaire légère (1), en particulier des constructions de bassin ou autres constructions de jardin, comprenant les étapes consistant à 35
- faire tourner au moins deux tubes (2) en pénétration dans le sous-sol (4), lesquels sont pourvus chacun d'une extrémité sensiblement creuse (12) sur le coté qui tourne en pénétration dans le sous-sol (4), et dans lequel des brides en forme de pas de vis (3) ont été prévues sur les tubes (2) pour être supportées dans le sous-sol (4), 50
 - régler la hauteur des tubes (2) en les faisant tourner axialement, 55
 - faire coulisser des pièces d'accouplement (5) sur des secondes extrémités (6) prévues sur
- chacun des tubes (2), dans lequel, pendant la construction, les pièces d'accouplement (5) sont supportées en étant capables de pivoter axialement librement sur les secondes extrémités (6).
- régler l'orientation axiale des pièces d'accouplement (5) en les faisant pivoter par rapport aux tubes respectifs et
 - attacher une poutre (7) sur les pièces d'accouplement (5).
16. Procédé pour ériger une construction modulaire selon la revendication 15, **caractérisé en ce que** le procédé comprend encore l'étape consistant à bloquer les pièces d'accouplement (5) dans une direction axiale par rapport aux tubes (2) après avoir réglé la hauteur des tubes (2) et avoir réglé l'orientation axiale des pièces d'accouplement (5).
17. Procédé pour ériger une construction de bassin selon le procédé de la revendication 15 ou 16, **caractérisé en ce que**, après lesdites étapes, on exécute encore les étapes suivantes :
- on creuse un bassin.
 - on pose une dans le bassin, et
 - on attache la feuille (11) sur la poutre (7).

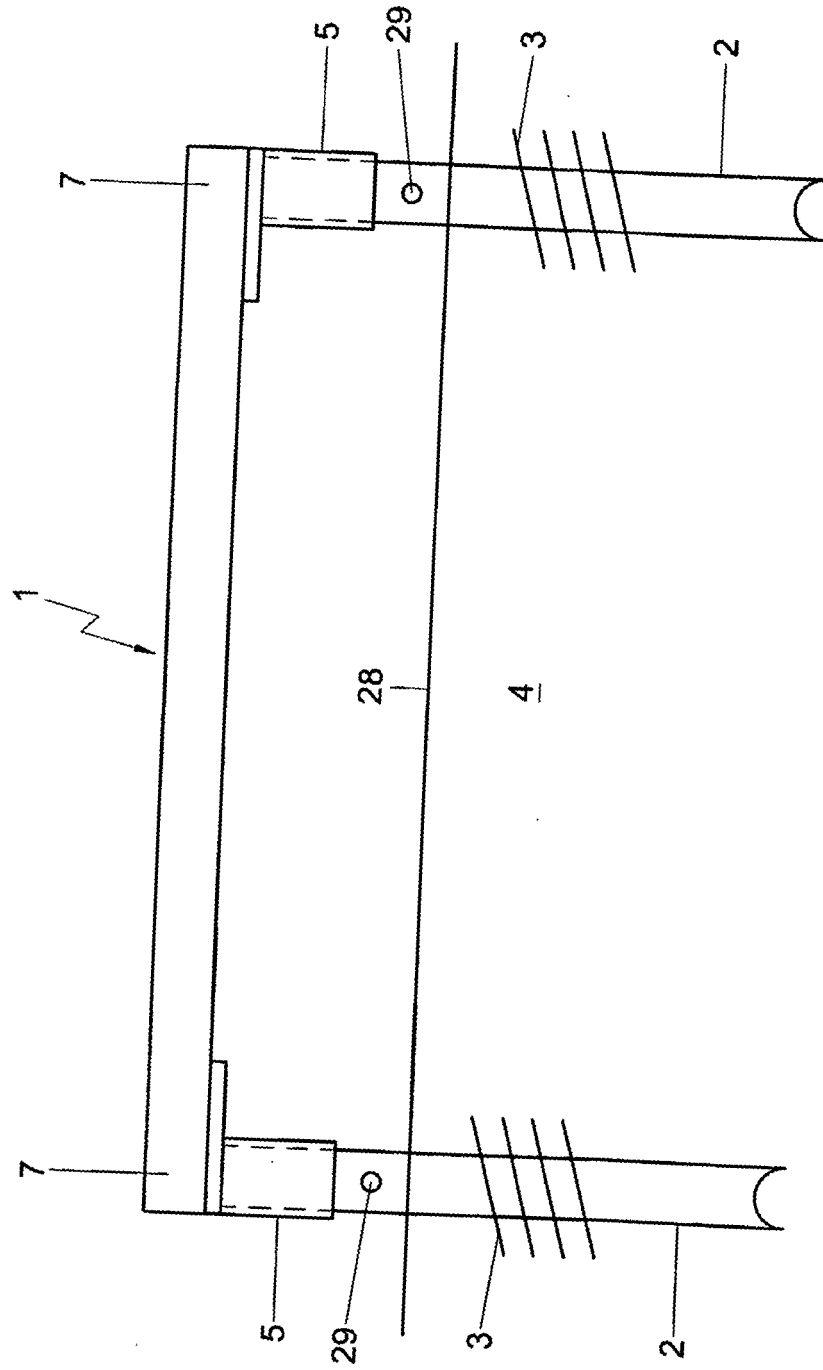

Fig. 1

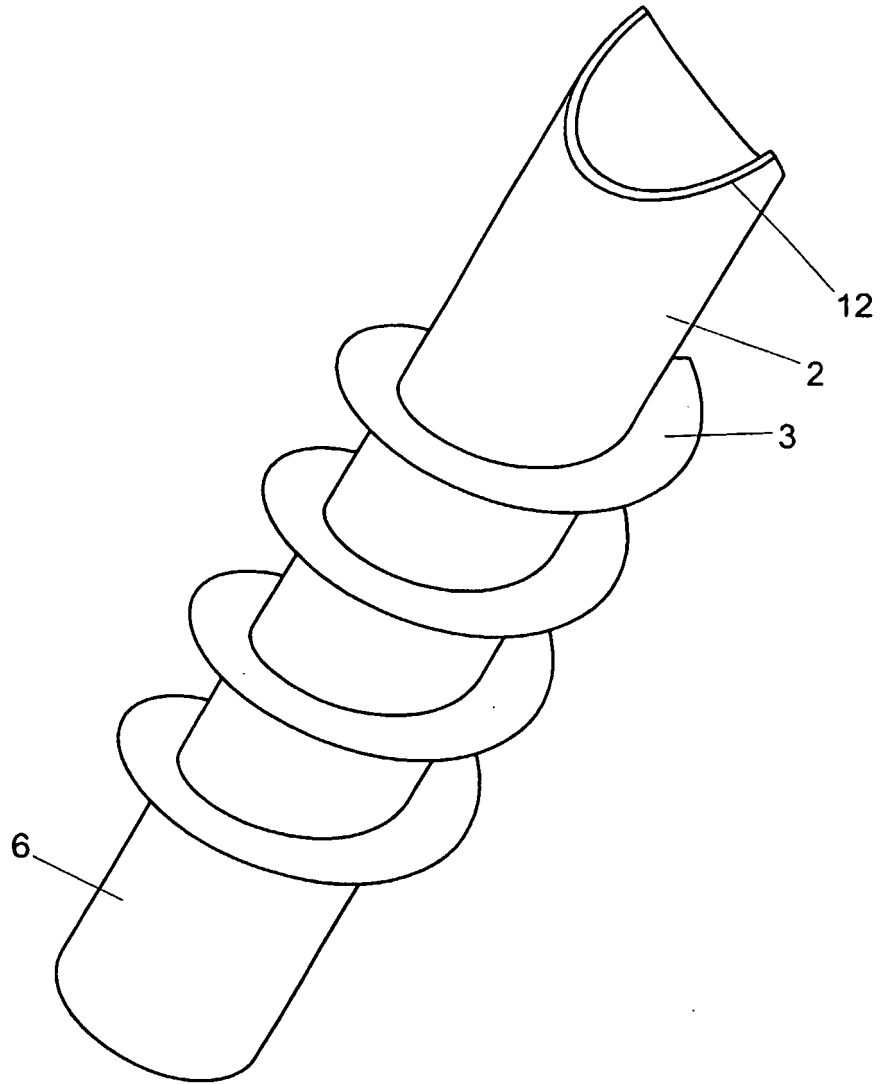

Fig. 2

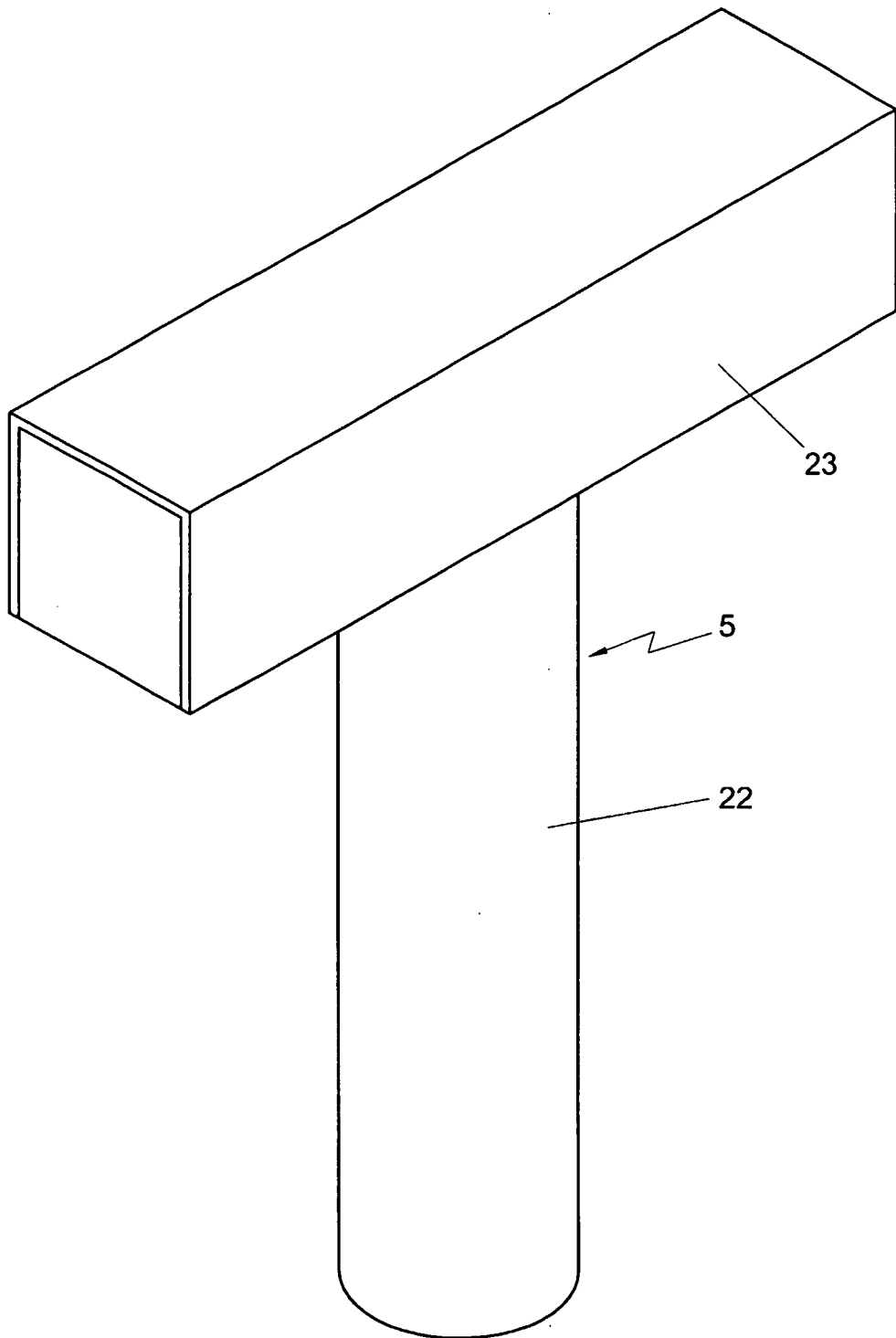

Fig. 3

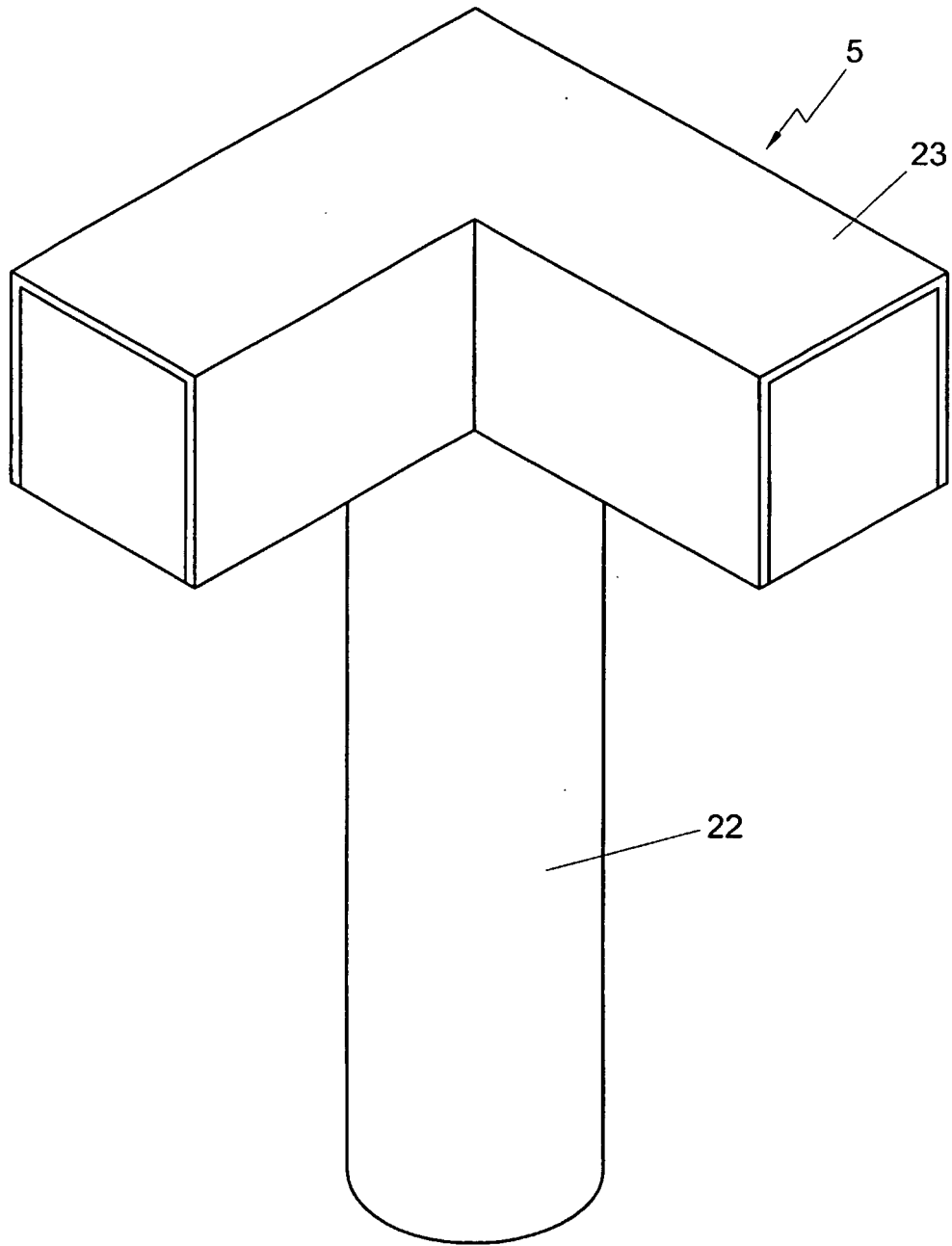

Fig. 4

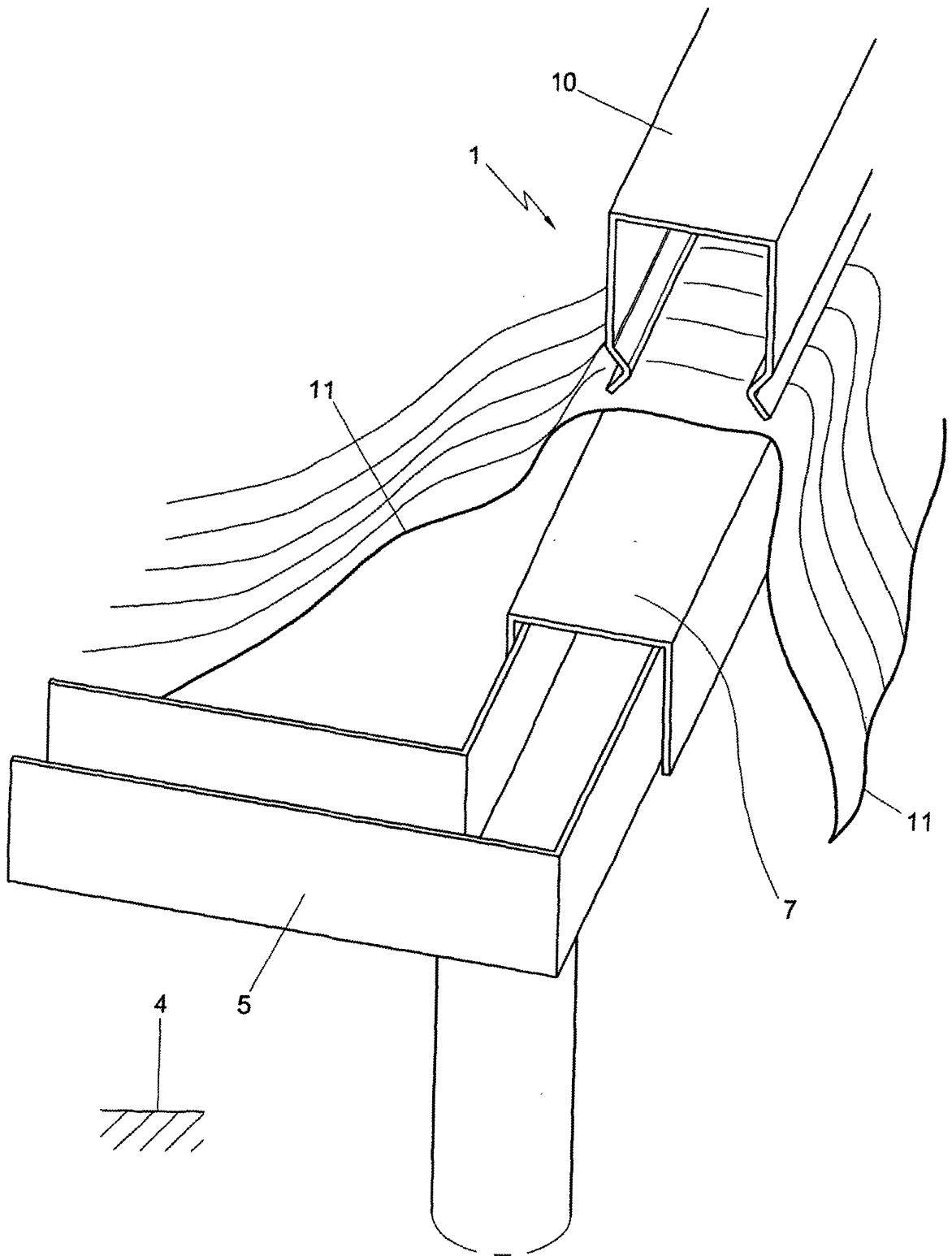

Fig. 5

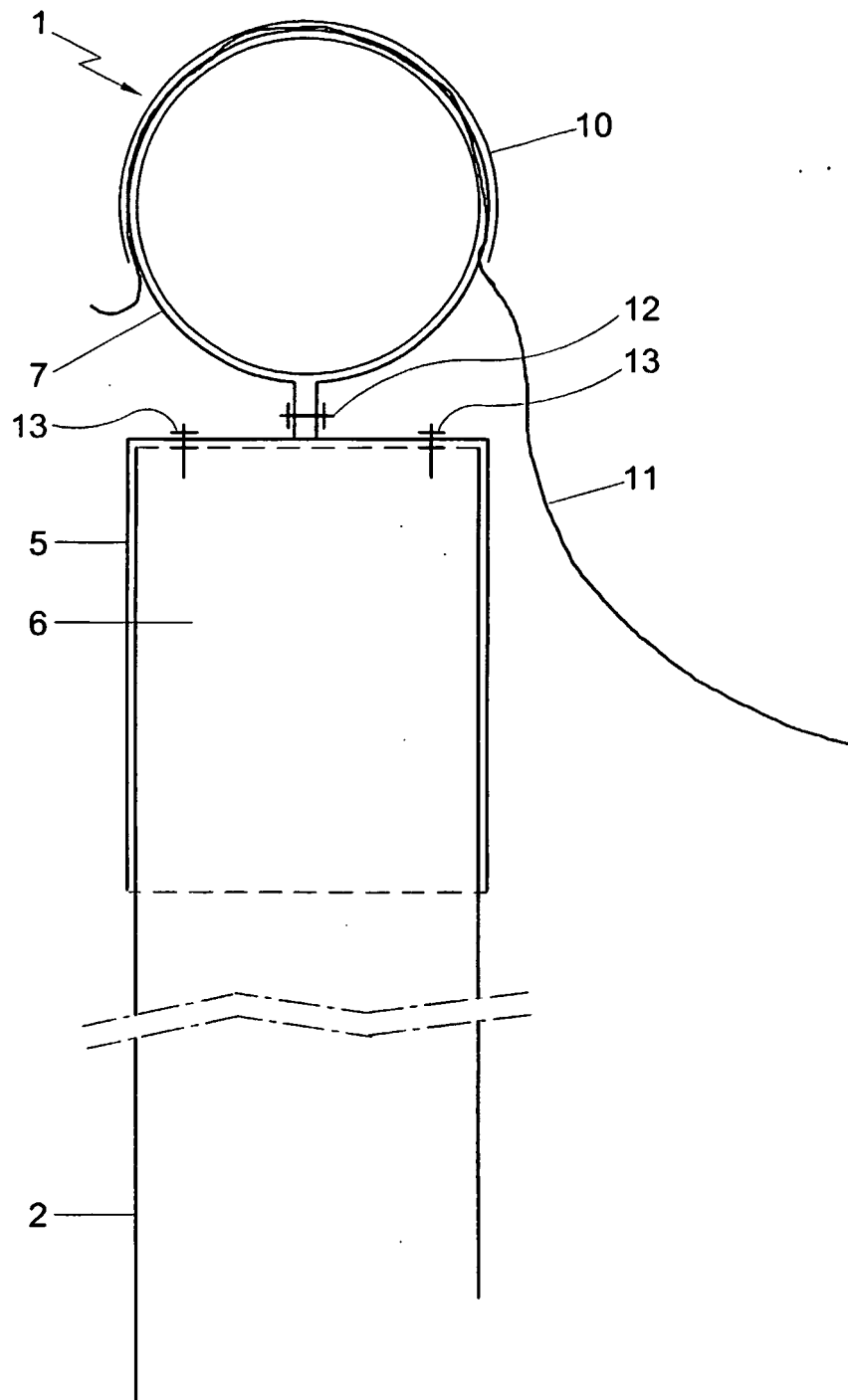

Fig. 6

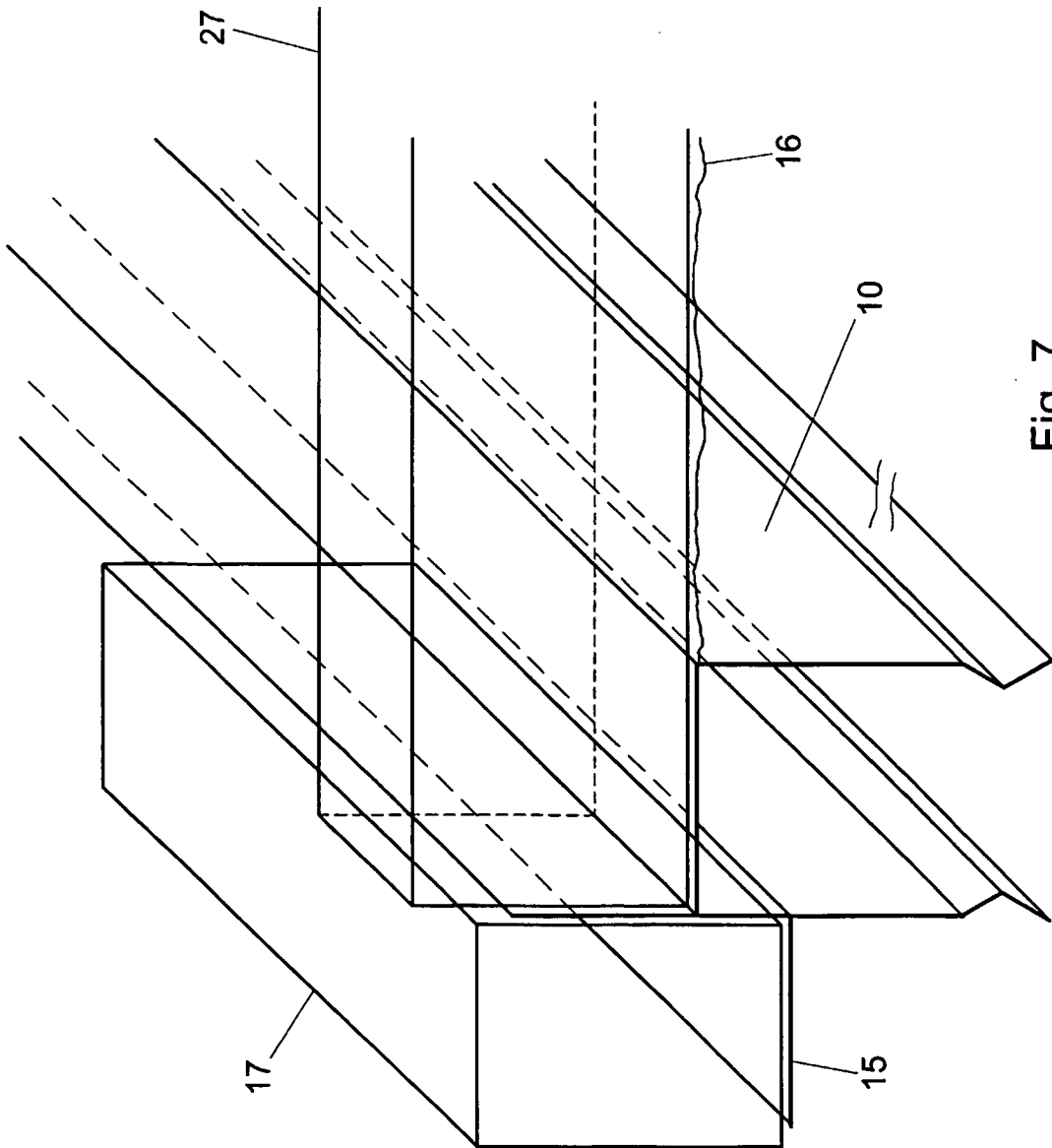

Fig. 7

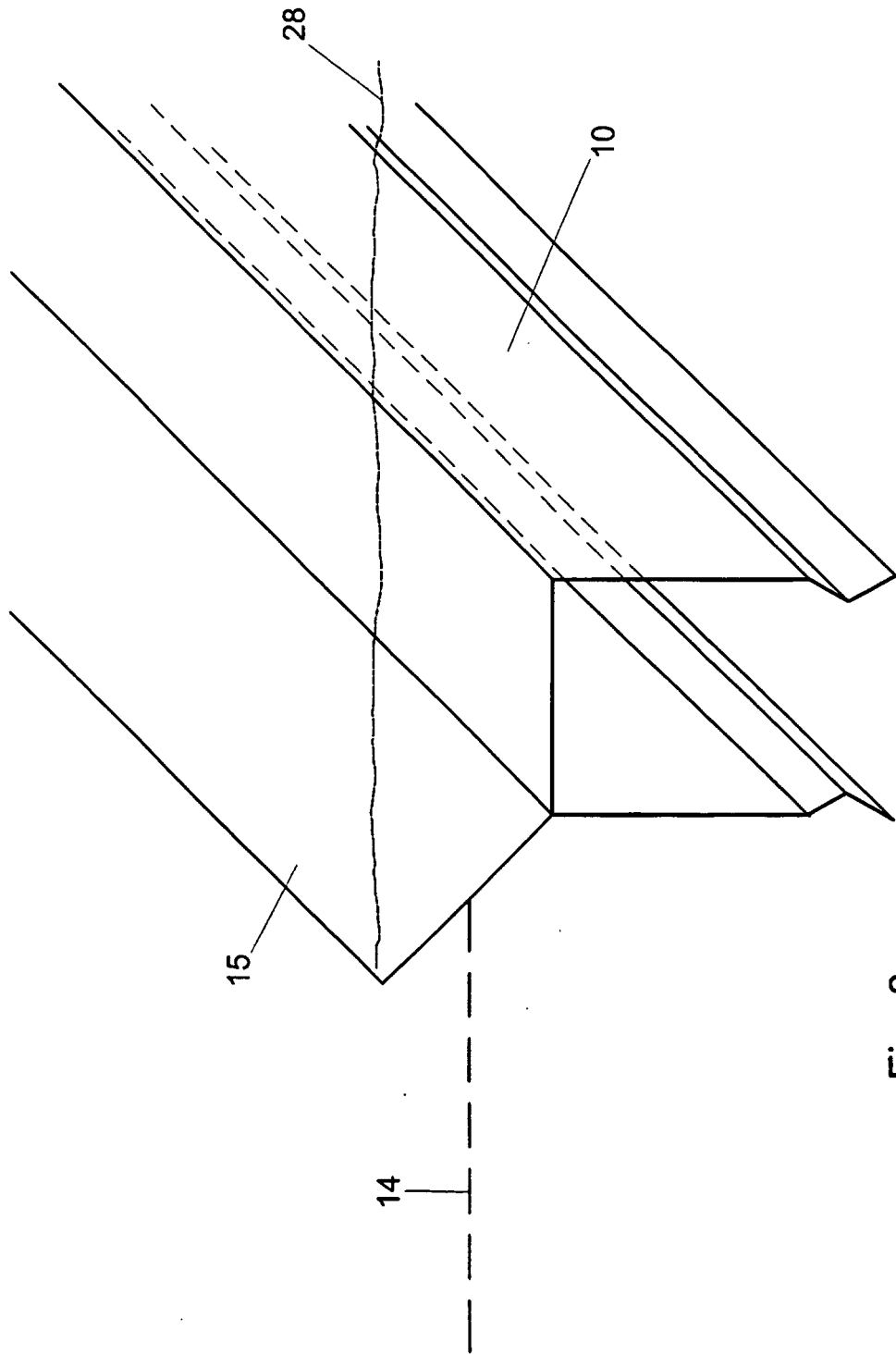

Fig. 8

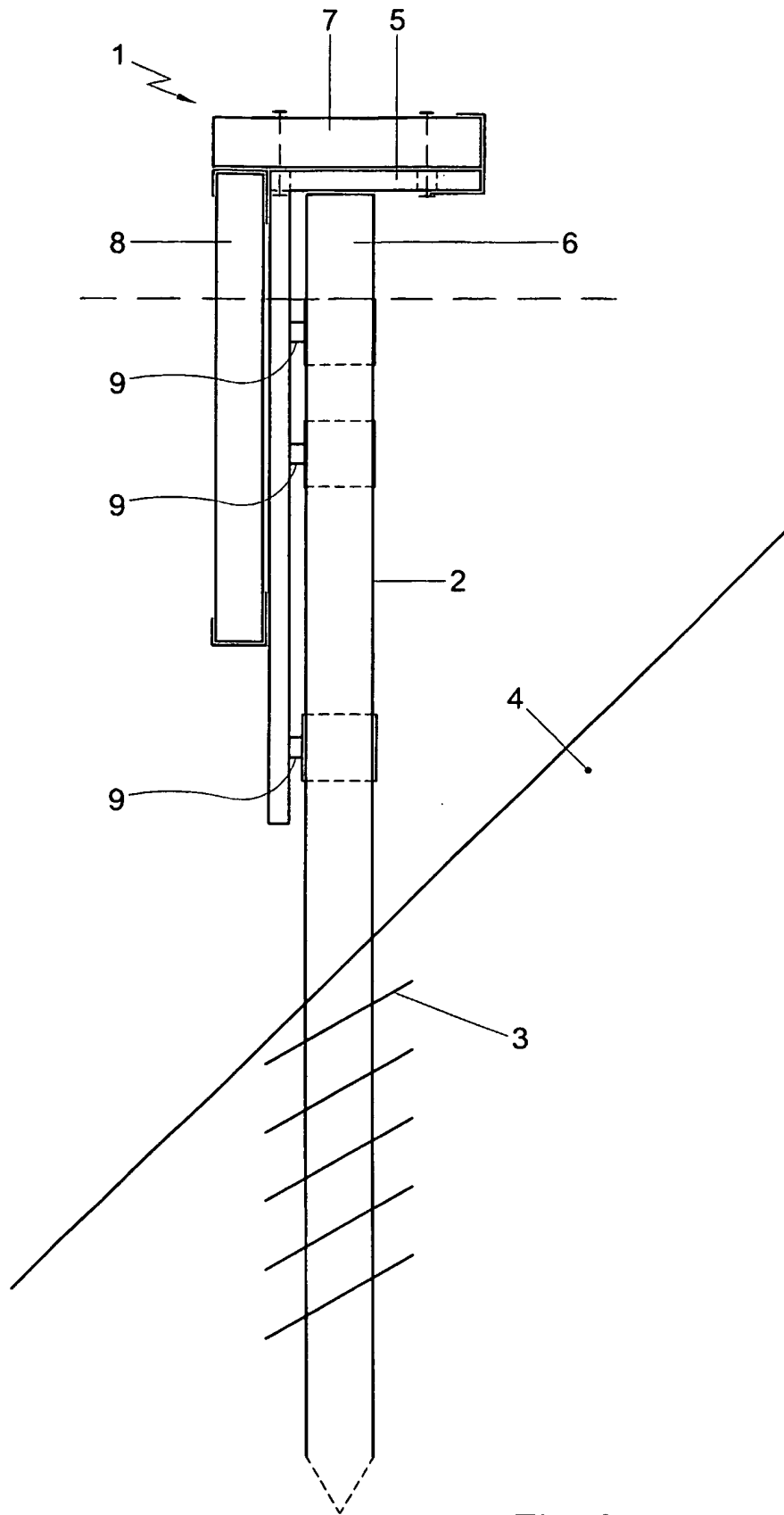

Fig. 9

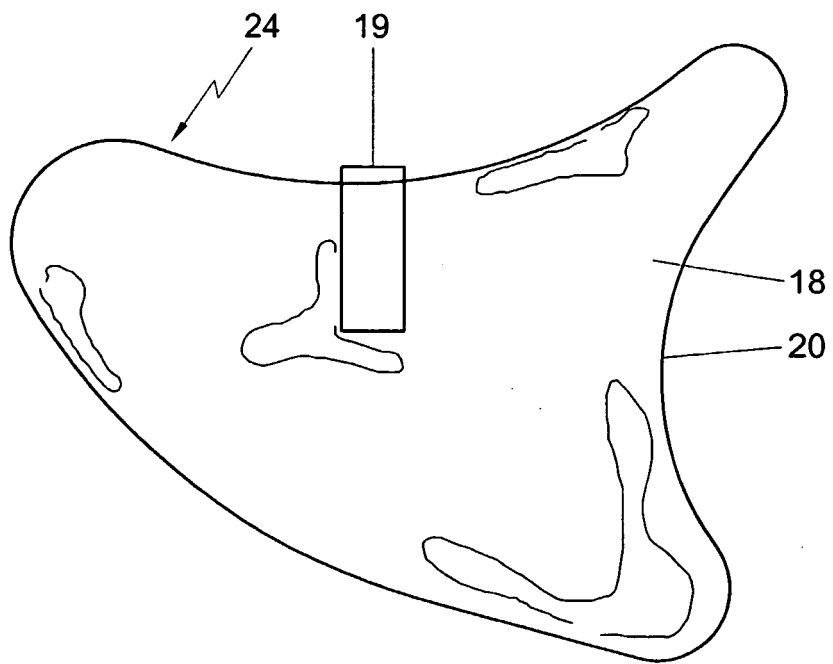

Fig. 10

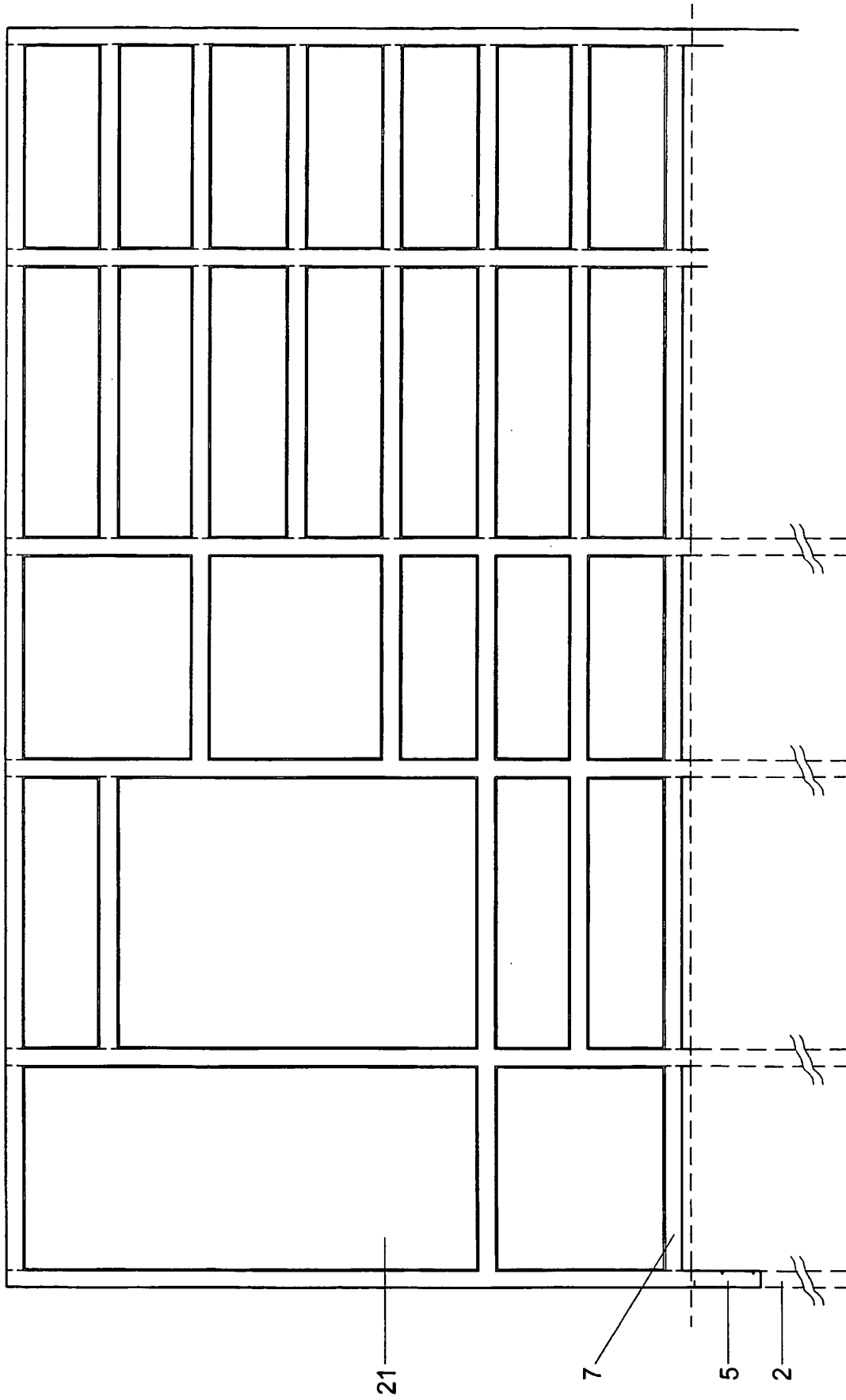

Fig. 11

REFERENCES CITED IN THE DESCRIPTION

This list of references cited by the applicant is for the reader's convenience only. It does not form part of the European patent document. Even though great care has been taken in compiling the references, errors or omissions cannot be excluded and the EPO disclaims all liability in this regard.

Patent documents cited in the description

- JP 1998000259194 B **[0004]**
- US 4405262 A **[0010]**